

**OPERATING AND  
MAINTENANCE  
MANUAL**

**MODEL  
3500 MARK II**

**GENERATOR DRIVE  
ENGINES**

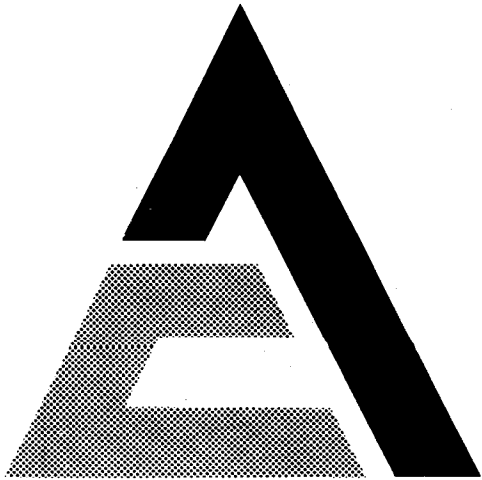

**ALLIS-CHALMERS**

**ENGINE DIVISION  
HARVEY, ILLINOIS 60426, USA**

Printed in USA

Form: TM-5071-1

(5-75)

9773 0013

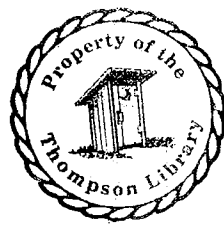

## **AVOID ACCIDENTS**

**MOST ACCIDENTS, WHETHER THEY OCCUR IN INDUSTRY, ON THE FARM, AT HOME OR ON THE HIGHWAY, ARE CAUSED BY THE FAILURE OF SOME INDIVIDUAL TO FOLLOW SIMPLE AND FUNDAMENTAL SAFETY RULES OR PRECAUTIONS. FOR THIS REASON MOST ACCIDENTS CAN BE PREVENTED BY RECOGNIZING THE REAL CAUSE AND DOING SOMETHING ABOUT IT BEFORE THE ACCIDENT OCCURS.**

**REGARDLESS OF THE CARE USED IN THE DESIGN AND CONSTRUCTION OF ANY TYPE OF EQUIPMENT THERE ARE MANY CONDITIONS THAT CANNOT BE COMPLETELY SAFEGUARDED AGAINST WITHOUT INTERFERING WITH REASONABLE ACCESSIBILITY AND EFFICIENT OPERATION.**

**IT IS THE RESPONSIBILITY OF USERS TO PROVIDE AND INSTALL GUARDS OR SAFETY DEVICES WHICH MAY BE REQUIRED BY RECOGNIZED SAFETY STANDARDS OR BY THE OCCUPATIONAL SAFETY AND HEALTH ACT OF 1970 AND ITS SUBSEQUENT PROVISIONS.**

**A careful operator is the best insurance against an accident. The complete observance of one simple rule would prevent many thousand serious injuries each year. That rule is:  
Never attempt to clean, oil or adjust a machine while it is in motion.**

## FOREWORD

This manual is provided to give the operator essential information regarding proper operation and maintenance of Allis-Chalmers diesel engines and auxiliary equipment.

The manual contains information and instructions on proper operation. To keep the unit operating at its maximum efficiency, the manual should be read by the operator and by those responsible for the maintenance of the unit.

An important item in prolonging the life of the unit is to keep dirt and other foreign particles away from its vital parts. Allis-Chalmers has taken precautions in the design of the equipment to safeguard against dirt and other foreign materials from reaching the working parts under normal operating conditions. The operator must also take precautions to assure that the oil, water, and fuel are always kept clean, and that air for combustion is always filtered. This can be accomplished by the proper storage and handling of fuel and lubricating oils and by following Allis-Chalmers recommendations in regard to lubricating oil specifications and change intervals, fuel specifications, maintenance of filters, air cleaner servicing, and proper care of the cooling system.

To assure the best results and maintain the high quality of the equipment, it is important that Allis-Chalmers parts are always used when new parts are required. **IMPORTANT: ALWAYS FURNISH MODEL AND ENGINE SERIAL NUMBER WHEN ORDERING PARTS.**

Many owners of Allis-Chalmers equipment rely upon the Service Department of our Dealers for all work other than routine maintenance and adjustment. This practice is encouraged as our Dealers are kept well informed by the factory regarding the most up-to-date methods of servicing Allis-Chalmers equipment and are equipped to render the most competent service.

# THE METRIC SYSTEM OF MEASUREMENT

Today's rapid communication and transportation between the nations of the world has resulted in the use of more of each other's products and services. This has caused a trend among the nations to adapt a standardization of units for use in both scientific and technical fields.

The customary United States (English) units and some metric units are being replaced with those of a modernized metric system known as the International System of Units which is officially abbreviated SI in all languages.

The SI or modernized metric system consists of six basic units:

Meter for length  
Kilogram for mass  
Second for time  
Ampere for electric current  
Kelvin for temperature  
Candela for luminous intensity

Because Allis-Chalmers' products are used worldwide and the adaptation of the SI metric system by all nations is getting nearer, both English and metric system of units appear in this manual.

To assist those not completely familiar with the metric system, the following nomenclature and tables will be of assistance.

## A. GENERAL NOMENCLATURE USAGE

|                 | METRIC   | ENGLISH                      |
|-----------------|--|------------------------------|
| Length          | millimeter (mm)                                    | inch (in)                    |
| Pressure        | kilonewton/meter <sup>2</sup> (kN/m <sup>2</sup> ) | pounds per square inch (PSI) |
| Force           | newton (N)   | pound (lb)                   |
| Mass            | kilogram (kg)                                      | pound (lb)                   |
| Time            | second (s)   | second (s)                   |
| Volume (liquid) | liter (l)  | gallon (gal)                 |
| Temperature     | kelvin (K)   | degrees fahrenheit (° F)     |
| Torque          | newton-meter (Nm)                                  | pound foot (lb-ft)           |
| Power           | kilowatt (kw)                                      | horsepower (hp)              |
| Frequency       | hertz (Hz)   | cycles per second (cps)      |

## B. CONVERSIONS FACTORS

| TO CONVERT                               | TO OBTAIN  | MULTIPLY BY             |
|--|--|-------------------------|
| Cubic Feet (cu ft)                       | Cubic Centimeters (cu cm)                        | 28320                   |
| Cubic Inches (cu in)                     | Cubic Centimeters (cu cm)                        | 16.39                   |
| Degree Centigrade (° C)                  | Kelvin (K)                                       | ° C + 273.15            |
| Degree Fahrenheit (° F)                  | Kelvin (K)                                       | (° F - 32) 5/9 + 273.15 |
| Feet (ft)                                | Meter (m)  | 0.3048                  |
| Gallon (gal)                             | Liter (l)  | 3.785                   |
| Inch (in)                                | Millimeter (mm)                                  | 25.40                   |
| Inches of Mercury (in of Hg)             | Newton per square meter (N/m <sup>2</sup> )      | 3376.85                 |
| Inches of Water (in of H <sub>2</sub> O) | Newton per square meter (N/m <sup>2</sup> )      | 248.84                  |
| Mile (mi)                                | Meter (m)  | 1609.344                |
| Miles per Hour (mi/hr)                   | Kilometer per hour (km/hr)                       | 1.6093                  |
| Ounces (oz)                              | Grams (g)  | 28.349                  |
| Ounces (oz)                              | Liter (l)  | 0.02957                 |
| Pound (lb)                               | Kilogram (kg)                                    | 0.4536                  |
| Pounds per square inch (PSI)             | Kilonewton per square meter (kN/m <sup>2</sup> ) | 6.894757                |
| Pounds per inch (lb in) (torque)         | Newtons per meter (Nm)                           | 0.1129848               |
| Pounds per foot (lb ft. (torque)         | Newtons per meter (Nm)                           | 1.355818                |
| Quart (qt)                               | Liter (l)  | 0.9463                  |
| Yard (yd)                                | Meter (m)  | 0.9144                  |

### C. QUICK REFERENCES CONVERSIONS (APPROXIMATE VALUES)

- One (1) Fahrenheit Degree: approximately equals .55 Centigrade Degree
- One (1) gallon: approximately equals 3 - 3/4 liters
- One (1) PSI: approximately equals 7 kN/m<sup>2</sup>
- One (1) in-lb of torque: approximately equals 0.11 Nm
- One (1) ft-lb of torque: approximately equals 1.35 Nm

### D. DECIMAL AND METRIC EQUIVALENTS OF FRACTIONS OF AN INCH

| INCHES    |          | MILLI-METERS | INCHES    |          | MILLI-METERS |
|-----------|----------|--------------|-----------|----------|--------------|
| FRACTIONS | DECIMALS |              | FRACTIONS | DECIMALS |              |
| 1/64      | .015625  | .40          | 33/64     | .515625  | 13.10        |
| 1/32      | .03125   | .79          | 17/32     | .53125   | 13.49        |
| 3/64      | .046875  | 1.19         | 35/64     | .546875  | 13.89        |
| 1/16      | .0625    | 1.59         | 9/16      | .5625    | 14.29        |
| 5/64      | .078125  | 1.98         | 37/64     | .578125  | 14.68        |
| 3/32      | .09375   | 2.38         | 19/32     | .59375   | 15.08        |
| 7/64      | .109375  | 2.78         | 39/64     | .609375  | 15.48        |
| 1/8       | .125     | 3.18         | 5/8       | .625     | 15.88        |
| 9/64      | .140625  | 3.57         | 41/64     | .640625  | 16.27        |
| 5/32      | .15625   | 3.97         | 21/32     | .65625   | 16.67        |
| 11/64     | .171875  | 4.37         | 43/64     | .671875  | 17.07        |
| 3/16      | .1875    | 4.76         | 11/16     | .6875    | 17.46        |
| 13/64     | .203125  | 5.16         | 45/64     | .703125  | 17.86        |
| 7/32      | .21875   | 5.56         | 23/32     | .71875   | 18.26        |
| 15/64     | .234375  | 5.95         | 47/64     | .734375  | 18.65        |
| 1/4       | .250     | 6.35         | 3/4       | .750     | 19.05        |
| 17/64     | .265625  | 6.75         | 49/64     | .765625  | 19.45        |
| 9/32      | .28125   | 7.14         | 25/32     | .78125   | 19.84        |
| 19/64     | .296875  | 7.54         | 51/64     | .796875  | 20.24        |
| 5/16      | .3125    | 7.94         | 13/16     | .8125    | 20.64        |
| 21/64     | .328125  | 8.33         | 53/64     | .828125  | 21.03        |
| 11/32     | .34375   | 8.73         | 27/32     | .84375   | 21.43        |
| 23/64     | .359375  | 9.13         | 55/64     | .859375  | 21.83        |
| 3/8       | .375     | 9.53         | 7/8       | .875     | 22.23        |
| 25/64     | .390625  | 9.92         | 57/64     | .890625  | 22.62        |
| 13/32     | .40625   | 10.32        | 29/32     | .90625   | 23.02        |
| 27/64     | .421875  | 10.72        | 59/64     | .921875  | 23.42        |
| 7/16      | .4375    | 11.11        | 15/16     | .9375    | 23.81        |
| 29/64     | .453125  | 11.51        | 61/64     | .953125  | 24.21        |
| 15/32     | .46875   | 11.91        | 31/32     | .96875   | 24.61        |
| 31/64     | .484375  | 12.30        | 63/64     | .984375  | 25.00        |
| 1/2       | .500     | 12.70        | 1         | 1.000    | 25.40        |

# TABLE OF CONTENTS

| TOPIC | TITLE   |      |
|-------|---|------|
| 1     | GENERAL DESCRIPTION . . . . .   | 1.1  |
| 2     | SPECIFICATIONS . . . . .  | 1.2  |
| 3     | PREPARATION OF ENGINE FOR OPERATION . . . . .   | 1.3  |
| 4     | OPERATING CONTROLS AND INSTRUMENTS . . . . .  | 1.4  |
| 5     | OPERATING INSTRUCTIONS . . . . .  | 1.5  |
| 6     | LUBRICATION RECOMMENDATIONS . . . . .   | 1.6  |
| 7     | FUEL OIL RECOMMENDATIONS . . . . .  | 1.7  |
| 8     | LUBRICATION AND MAINTENANCE SCHEDULE, AND MAINTENANCE TOOLS . . . . .                                     | 1.8  |
| 9     | TROUBLESHOOTING . . . . .   | 1.9  |
| 10    | FITS AND TOLERANCES; BOLT, CAPSCREW AND NUT TORQUE WRENCH<br>SPECIFICATIONS; STUD GAUGE HEIGHTS . . . . . | 1.10 |
| 11    | COOLING SYSTEM . . . . .  | 1.11 |
| 12    | FUEL SYSTEM . . . . .   | 1.12 |
| 13    | LUBRICATION SYSTEM . . . . .  | 1.13 |
| 14    | ELECTRICAL SYSTEM . . . . .   | 1.14 |
| 15    | VALVE ADJUSTMENT AND CYLINDER HEAD . . . . .  | 1.15 |
| 16    | INTAKE AND EXHAUST SYSTEMS . . . . .  | 1.16 |
| 17    | AIR CLEANER . . . . .   | 1.17 |
| 18    | TURBOCHARGER . . . . .  | 1.18 |
| 19    | SAFETY CONTROLS . . . . .   | 1.19 |
| 20    | COLD WEATHER STARTING AIDS . . . . .  | 1.20 |

8

(1

(1

(1



INDEX

**OPERATING AND MAINTENANCE INSTRUCTIONS**

| TOPIC | TITLE  | PAGE |
|-------|--|------|
| 1     | DESCRIPTION.....<br>A. GENERAL<br>B. PRINCIPLES OF OPERATION<br>C. ENGINE STROKE SEQUENCE  | 1.1  |
| 2     | SPECIFICATIONS.....<br>A. ENGINE (BASIC)<br>B. COOLING SYSTEM<br>C. LUBRICATION SYSTEM<br>D. FUEL INJECTION SYSTEM<br>E. VALVE DATA<br>F. GOVERNOR<br>G. ELECTRICAL SYSTEM   | 2.1  |
| 3     | PREPARATION OF ENGINE FOR OPERATION.....<br>A. SAFETY PRECAUTIONS<br>B. PROCEDURE  | 3.1  |
| 4     | OPERATING CONTROLS AND EQUIPMENTS.....<br>A. GENERAL   | 4.1  |
| 5     | OPERATING INSTRUCTIONS.....<br>A. GENERAL<br>B. OPERATING PRECAUTIONS<br>C. STARTING AND STOPPING ENGINE<br>D. DURING OPERATION CHECKS<br>E. COLD WEATHER CHECKS<br>F. HOT WEATHER CHECKS<br>G. EXERCISE OF ENGINE ON STANBY SERVICE<br>H. ENGINE STORAGE            | 5.1  |
| 6     | LUBRICATION RECOMMENDATIONS.....<br>A. ENGINE LUBRICATING OIL<br>B. GREASE   | 6.1  |
| 7     | FUEL OIL RECOMMENDATIONS.....<br>A. GENERAL<br>B. FUEL OIL CHARACTERISTICS<br>C. HANDLING AND STORAGE OF FUEL OIL  | 7.1  |
| 8     | LUBRICATION AND MAINTENANCE SCHEDULE, AND<br>MAINTENANCE TOOLS.....<br>A. GENERAL<br>B. LUBRICATION AND MAINTENANCE GUIDE<br>C. MAINTENANCE TOOLS  |      |
| 9     | TROUBLESHOOTING.....<br>A. GENERAL<br>B. ENGINE<br>C. STARTING SYSTEM<br>D. FUEL SYSTEM<br>E. AIR INTAKE SYSTEM<br>F. COOLING SYSTEM<br>G. LUBRICATING SYSTEM<br>H. ELECTRICAL SYSTEM<br>I. INSTRUMENTS<br>J. LOCATING CYLINDER CUTOUT<br>K. MAKING COMPRESSION TEST | 8.1  |

INDEX (CONTINUED)

| TOPIC | TITLE   | PAGE |
|-------|---|------|
| 10    | FITS AND TOLERANCES: BOLT, CAPSCREW AND NUT TORQUE WRENCH SPECIFICATIONS: STUD GAUGE HEIGHTS..... | 1.10 |
|       | A. FITS AND TOLERANCES  |      |
|       | B. TORQUE SPECIFICATIONS - BOLT, CAPSCREW AND NUT   |      |
|       | C. STUD GAUGE HEIGHTS   |      |
| 11    | COOLING SYSTEM.....   | 1.11 |
|       | A. GENERAL  |      |
|       | B. RADIATOR AND FAN TYPE COOLING SYSTEM   |      |
|       | C. HEAT EXCHANGER AND EXPANSION TANK TYPE COOLING SYSTEM  |      |
|       | D. GENERAL MAINTENANCE  |      |
|       | E. DRAINING COOLING SYSTEM  |      |
|       | F. FILLING COOLING SYSTEM   |      |
|       | G. CLEANING OF COOLING SYSTEM   |      |
|       | H. ENGINE OIL COOLER  |      |
|       | I. THERMOSTATS  |      |
|       | J. BELTS AND ADJUSTMENT   |      |
|       | K. COOLING SYSTEM CONDITIONER   |      |
| 12    | FUEL SYSTEM.....  | 1.12 |
|       | A. GENERAL  |      |
|       | B. FUEL FILTER AND OPTIONAL FUEL AND WATER SEPARATOR  |      |
|       | C. PRIMING THE FUEL SYSTEM  |      |
|       | D. FUEL INJECTION PUMP  |      |
|       | E. GOVERNOR   |      |
|       | F. FUEL INJECTION NOZZLE HOLDER ASSEMBLY  |      |
|       | G. REMOVING CARBON FROM FUEL INJECTION NOZZLE BORE  |      |
|       | H. CHECKING FUEL SYSTEM   |      |
|       | I. HAND PRIMER PUMP   |      |
|       | J. SPEED CONTROL MOTOR  |      |
| 13    | LUBRICATION SYSTEM.....   | 1.13 |
|       | A. GENERAL  |      |
|       | B. GENERAL MAINTENANCE  |      |
|       | C. FULL-FLOW LUBRICATION OIL FILTERS  |      |
|       | D. BYPASS OIL FILTER (OPTIONAL)   |      |
|       | E. DRAINING AND FILLING THE LUBRICATING SYSTEM  |      |
|       | F. ENGINE OIL COOLER  |      |
|       | G. LUBRICATING SYSTEM MAINTENANCE   |      |
| 14    | ENGINE ELECTRICAL SYSTEM.....   | 1.14 |
|       | A. GENERAL  |      |
|       | B. WARRANTY AND ADJUSTMENT  |      |
|       | C. BATTERY  |      |
|       | D. ELECTRIC STARTING MOTOR  |      |
|       | E. ALTERNATOR   |      |
|       | F. VOLTAGE REGULATOR  |      |
|       | G. ALTERNATOR DRIVE BELT ADJUSTMENT   |      |
|       | H. AIR HEATER   |      |
| 15    | VALVE ADJUSTMENT AND CYLINDER HEAD.....   | 1.15 |
|       | A. VALVE LASH ADJUSTMENT  |      |
|       | B. TORQUING CYLINDER HEAD CAPSCREWS   |      |

INDEX (CONTINUED)

| TOPIC | TITLE   | PAGE |
|-------|---|------|
| 16    | INTAKE AND EXHAUST SYSTEMS.....<br>A. GENERAL<br>B. MANIFOLD MAINTENANCE  | 1.16 |
| 17    | AIR CLEANER.....<br>A. GENERAL<br>B. SERVICE<br>C. AIR FILTER SERVICE INDICATOR   | 1.17 |
| 18    | TURBOCHARGER.....<br>A. GENERAL<br>B. OPERATION<br>C. EFFECT OF ALTITUDE ON TURBOCHARGED<br>ENGINES<br>D. MAINTENANCE<br>E. 2600-HOUR INSPECTION                                | 1.18 |
| 19    | SAFETY CONTROLS.....<br>A. GENERAL<br>B. DRIVE ASSEMBLY   | 1.19 |
| 20    | COLD WEATHER STARTING AIDS.....<br>A. GENERAL<br>B. HANDLING PRECAUTIONS<br>C. FUEL CYLINDER INSTALLATION<br>D. OPERATION OF DISCHARGER<br>E. MAINTENANCE<br>F. TROUBLESHOOTING | 1.20 |

9

## TOPIC 1. DESCRIPTION

### A. GENERAL

The engine model covered in this manual is a turbocharged, 4-cycle, water cooled, overhead valve, compression-ignition type diesel engines with 6 vertical, in-line cylinders, and is equipped with piston cooling jets.

The basic engine, engine assemblies, and power units have been engineered with equipment necessary for usual installation requirements. All units can be modified for various applications by addition of optional equipment.

The furnishing of pertinent data regarding the operation and maintenance of equipment and accessories not originally supplied by Allis-Chalmers is the responsibility of the company that assembles the accessories to the engine.

Engines shipped from Allis-Chalmers are equipped with a combination name plate and optional equipment plate. The engine serial number and engine catalog number are stamped in the name plate section, the remainder of the plate is used to list the catalog numbers of the various optional equipment groups as specified on the original factory order, together with the specific factory shipping order number.

NOTE: To obtain shipment promptly when ordering repair parts, always give the information on the engine name plate, and the repair part number and name. Order parts from the dealer covering the local territory.

### B. PRINCIPLES OF OPERATION

The fuel system consists of a fuel filter,

differential needle type fuel injection nozzle holder assemblies, and fuel injection pump with fuel transfer pump and governor. The system cleans, prepares, and delivers accurately metered quantities of fuel under high pressure to the engine cylinders where it is ignited by heat of air compressed in the cylinders.

Proper lubrication is assured by a gear type lubrication oil pressure pump. Oil is pumped under 30-55 psi (207-379 kN/m<sup>2</sup>) pressure from the main oil gallery to the crankshaft, connecting rods, idler gear, and rocker arm assembly. All other internal moving parts are lubricated by splash, spray, and oil in suspension.

A turbocharger is used to obtain greater power output over that of the naturally aspirated model engine by increasing the supply of air to the cylinders. The turbocharger is essentially a rugged yet highly efficient exhaust driven blower.

The turbocharger responds to engine load demands by reacting to the flow of expanding exhaust gases and supplying a correlated volume of air to engine cylinders. During a heavy load/lugging operation, the increased flow of exhaust gases turns the turbine wheel faster, causing the compressor impeller to turn faster to supply more air to the intake manifold. Conversely, when engine load is light and the radial flow of gases within the turbine decreases, the turbocharger compressor reduces air supply to the intake manifold.

### C. ENGINE STROKE SEQUENCE

In a 4-cycle diesel engine, a power stroke is made by each piston every two complete revolutions of the crankshaft. Sequence of strokes is intake, compression, power, and exhaust.

| CATALOG NO. | OPT. EQUIP. | CATALOG NO. | OPT. EQUIP. | CATALOG NO. | OPT. EQUIP. |
|-------------|-------------|-------------|-------------|-------------|-------------|
|             |             |             |             |             |             |

**ALLIS-CHALMERS**  
HARVEY, ILLINOIS • MADE IN U.S.A.

|            |             |
|------------|-------------|
| SERIAL NO. | CATALOG NO. |
|            |             |

MODEL

E-2398

Combination Engine Name Plate and  
Optional Equipment Plate

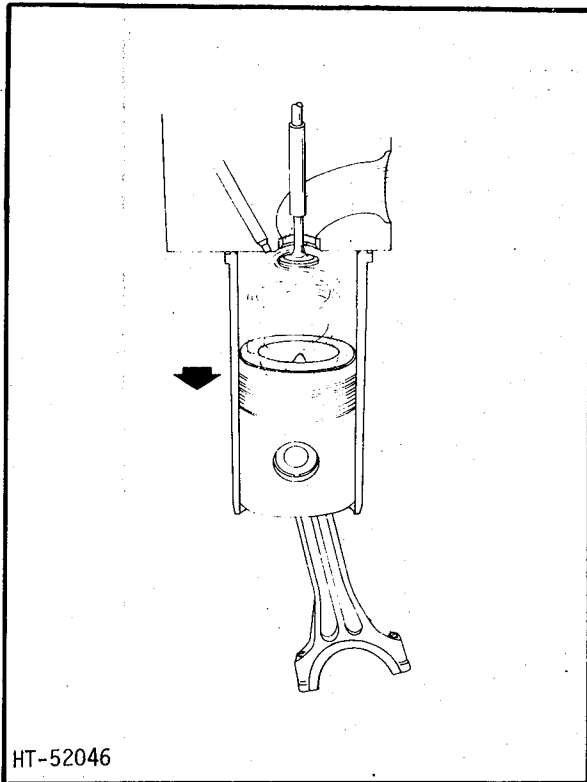

Figure 1. Intake Stroke

### 1. Intake Stroke

As the piston moves downward on the first, or intake stroke, air enters the cylinder through the air intake manifold and intake valve, which starts to open a few degrees before the piston reaches top dead center. The intake charge, consisting of air only, rushes into the cylinder and is given a swirling motion by directional ports in the cylinder head.

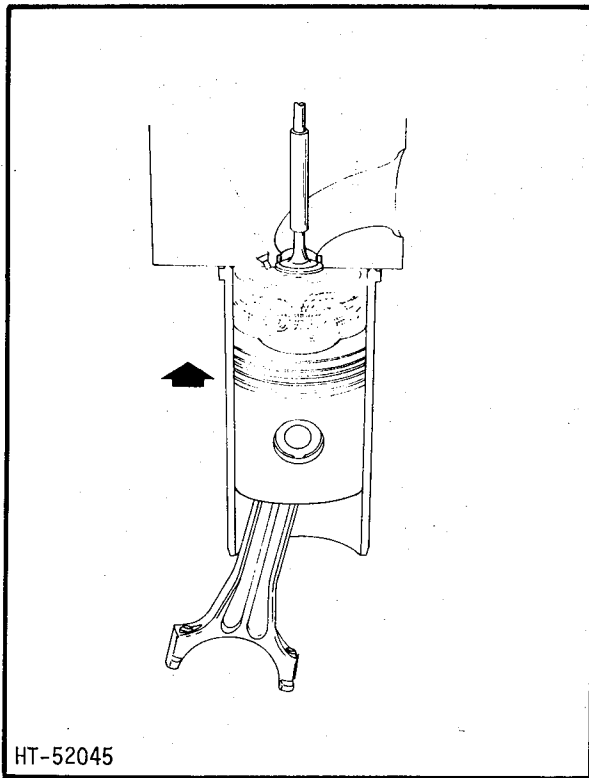

Figure 2. Compression Stroke

### 2. Compression Stroke

Shortly after the piston starts to move upward on the second, or compression stroke the intake valve closes. The swirling motion of air admitted on the intake stroke is intensified during the compression stroke and its temperature is raised to approximately 1000°F (811 K). The contoured piston top compresses and simultaneously forces the air toward its center, giving it an additional rolling motion and greater velocity. At the proper instant during the compression stroke, a metered quantity of fuel is injected into the combustion chamber in a four-jet pattern under extremely high pressure. When the finely atomized fuel has mixed thoroughly with the turbulent air it is ignited by heat of the compressed air and immediately starts to burn.

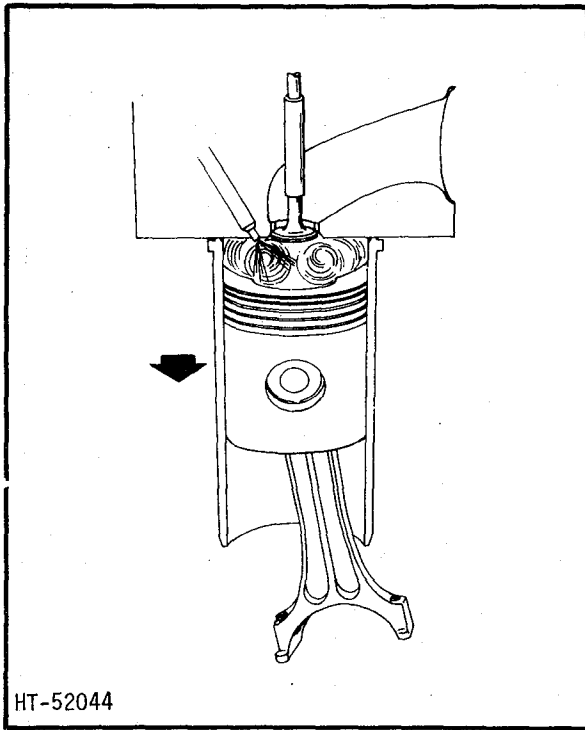

Figure 3. Power Stroke

### 3. Power Stroke

Because the fuel and air is thoroughly mixed in the cylinder, it burns smoothly and evenly. As the burning gases expand they force the piston downward on its third, or power stroke. Near bottom of the power stroke the exhaust valve starts to open.

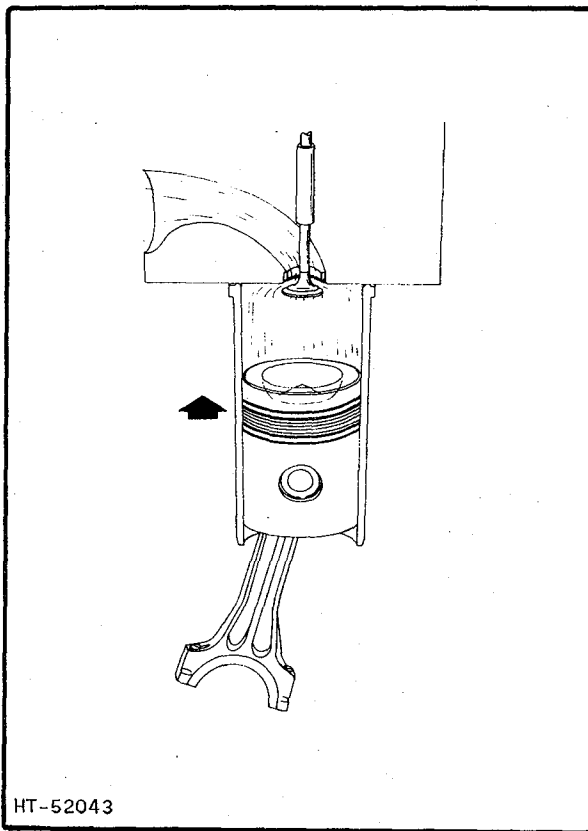

Figure 4. Exhaust Stroke

### 4. Exhaust Stroke

As the piston moves upward on the fourth, or exhaust stroke, the exhaust valve opens and burned gases are forced out of the cylinder by the upward travel of the piston. Shortly before the piston reaches top dead center, the intake valve starts to open to admit a fresh charge of air to the cylinder. A few degrees after the piston reaches top dead center, the exhaust valve closes completely, denoting the end of one cycle and beginning of the next.

0



## TOPIC 2. SPECIFICATIONS

Allis-Chalmers reserves the right to make changes in the following specifications and to add improvements at any time without notice or obligation.

|   | ENGLISH                        | METRIC   |
|---|--------------------------------|--|
| <b>A. ENGINE (BASIC)</b>  |                                |  |
| Model 3500MKII . . . . .  | Turbocharged                   | Turbocharged                                   |
| Type . . . . .  | 4 cycle                        | 4 cycle  |
| Number of Cylinders . . . . .   | 6                              | 6  |
| Firing Order . . . . .  | 1-5-3-6-2-4                    | 1-5-3-6-2-4                                    |
| Bore . . . . .  | 4.25 in.                       | 108 mm   |
| Stroke . . . . .  | 5.00 in.                       | 127 mm   |
| Displacement . . . . .  | 426 cu. in.                    | 6982 cm <sup>3</sup>                           |
| Crankshaft Rotation (viewed from fan end) . . . . .   | Clockwise                      | Clockwise                                      |
| Number of Main Bearings . . . . .   | 7                              | 7  |
| Compression Ratio (nominal) . . . . .   | 16.1                           | 16.1   |
| Compression Pressure at Sea Level, 600 rpm,<br>Hot . . . . .  | 500 psi ± 15 psi               | 3447 kN/m <sup>2</sup> ± 103 kN/m <sup>2</sup> |
| Maximum Permissible Exhaust Restriction:<br>Model 3500MKII . . . . .  | 2 in. Hg                       | 0.069 kg/cm <sup>2</sup>                       |
| <b>B. COOLING SYSTEM</b>  |                                |  |
| Water Pump, Centrifugal Type . . . . .  | Belt Driven                    | Belt Driven                                    |
| Stablized Coolant Temperature (minimum) . . . . .   | 180° F                         | 355 K  |
| Radiator and Expansion Tank Cap (pressurized) . . . . .   | 7 psi                          | 48 kN/m <sup>2</sup>                           |
| Nominal Capacities:   |                                |  |
| 1. Basic Engine with Dry Exhaust Manifold<br>3500MKII . . . . .   | 15.5 qts*                      | 14.66 lts*                                     |
| *NOTE: To obtain total capacity of cooling system for particular application,<br>add basic engine capacity to capacity of applicable optional cooling system<br>equipment listed below: |                                |  |
| 2. Optional Cooling System Equipment:   |                                |  |
| Radiator & Hoses - 105° F (314K) Ambient . . . . .  | 23.8 qts                       | 22.54 lts                                      |
| Radiator & Hoses - 125° F (325K) Ambient . . . . .  | 28.4 qts                       | 26.90 lts                                      |
| Water Cooled Exhaust Manifold . . . . .   |                                |  |
| Heat Exchanger and Expansion Tank . . . . .   |                                |  |
| <b>C. LUBRICATION SYSTEM</b>  |                                |  |
| Type . . . . .  | Circulating<br>Pressure System | Circulating<br>Pressure System                 |
| Oil Pump . . . . .  | Gear Type                      | Gear Type                                      |
| Pressure Control . . . . .  | Regulating Valve               | Regulating Valve                               |
| Standard Oil Filters . . . . .  | Full Flow Type                 | Full Flow Type                                 |
| Supplemental Oil Filter (Optional) . . . . .  | Bypass Type                    | Bypass Type                                    |
| Oil Pressure Range, Hot:  |                                |  |
| Full Load Speed, 1800 rpm . . . . .   | 30 to 55 psi                   | 207 to 379 kN/m <sup>2</sup>                   |
| Idle Speed, 600-700 rpm . . . . .   | 10 psi minimum                 | 69 kN/m <sup>2</sup> minimum                   |
| Nominal Oil Capacities:   |                                |  |
| Filter and Oil Change Quantity:   |                                |  |
| Oil Pan and Full Flow Filter . . . . .  | 25 qts**                       | 23.66 lts**                                    |
| **NOTE: Add 6 qts (6.62 lts) if engine is equipped with optional bypass type<br>oil filter.   |                                |  |
| <b>D. FUEL INJECTION SYSTEM</b>   |                                |  |
| Nozzle Holder Assembly Mfr. . . . .   | Allis-Chalmers                 | Allis-Chalmers                                 |
| Fuel Injection Pump Mfr . . . . .   | Roosa Master                   | Roosa Master                                   |
| Nozzle, Spring Loaded Type . . . . .  | Four Hole Orifices             | Four Hole Orifices                             |
| Opening Pressure . . . . .  | 3100-3150 psi                  | 21374-21718 kN/m <sup>2</sup>                  |

|  | ENGLISH       | METRIC        |
|--|---------------|---------------|
| Orifice Size. . . . .  | 0.0138 in     | 0.35 mm       |
| Fuel Oil Filter . . . . .  | Pleated Paper | Pleated Paper |
| Fuel Transfer Pump and Hand Primer Pump . . . . .  | 3 ft          | 914.40 mm     |
| Fuel Pump Timing to Engine (Static):   |               |               |
| NOTE: The number of degrees the injection pump is timed to the engine depends upon the type of injection pump applied to the engine. See appropriate data listed below:  |               |               |
| Standard Injection Pump with Automatic Advance and 3 1/2-5% Regulation 1500-1800 rpm . . . . .   | 24° BTDC      | 24° BTDC      |
| Optional Injection Pump without Automatic Speed Advance and with 1-5% Regulation Hydraulic Governor, 1500-1800 rpm. . . . .  | 36° BTDC      | 36° BTDC      |
| E. VALVE DATA  |               |               |
| 1. Valve Lash Adjustment   |               |               |
| Intake Valve Clearance - Hot. . . . .  | 0.015 in      | 0.38 mm       |
| Exhaust Valve Clearance - Hot . . . . .  | 0.015 in      | 0.38 mm       |
| 2. Valve Timing:   |               |               |
| Exhaust Valve w/Tappet Clearance of . . . . .  | 0.0195 in     | 0.50 mm       |
| Opens BBDC. . . . .  | 56°           | 56°           |
| Closes ATDC . . . . .  | 16°           | 16°           |
| Duration. . . . .  | 252°          | 252°          |
| Intake Valves w/Tappet Clearance of . . . . .  | 0.0195 in     | 0.50 mm       |
| Opens BTDC. . . . .  | 20°           | 20°           |
| Closes ABDC . . . . .  | 48°           | 48°           |
| Duration. . . . .  | 248°          | 248°          |
| CAUTION: Tappets must be set with 0.0195 in (0.50 mm) clearance to obtain proper valve opening and closing in degrees tabulated for the camshaft. Do not confuse this setting with valve lash adjustment data. |               |               |
| F. GOVERNOR  |               |               |
| Manufacture . . . . .  | Roosa Master  | Roosa Master  |
| Standard Type . . . . .  | Mechanical    | Mechanical    |
| Optional Type . . . . .  | Hydraulic     | Hydraulic     |
| Regulation:  |               |               |
| Standard . . . . .   | 3.5-5%        | 3.5-5%        |
| Optional . . . . .   | 1-5%          | 1-5%          |
| Speed Settings:  |               |               |
| Full Load - 50 Hz. . . . .   | 1500 rpm      | 1500 rpm      |
| Full Load - 60 Hz. . . . .   | 1800 rpm      | 1800 rpm      |
| Low Speed - 50 Hz and 60 Hz. . . . .   | 1400 rpm      | 1400 rpm      |
| G. ELECTRICAL SYSTEM   |               |               |
| Starter-Standard. . . . .  | 12 v          | 12 v          |
| Starter-Optional. . . . .  | 24 v          | 24 v          |
| Alternator-Standard . . . . .  | 12 v, 40 amp  | 12 v, 40 amp  |
| Alternator-Optional . . . . .  | 24 v, 30 amp  | 24 v, 30 amp  |
| Ground Polarity . . . . .  | Negative      | Negative      |

## TOPIC 3. PREPARATION OF ENGINE FOR OPERATION

### A. SAFETY PRECAUTIONS

1. When operating the engine in a closed area, pipe exhaust fumes outside. Continued breathing of exhaust fumes may be fatal.
2. When servicing batteries, do not smoke or use an open flame in the vicinity. Batteries generate explosive gas during charging. Make sure there is adequate ventilation when charging batteries.
3. When filling fuel tank, always provide metal-to-metal contact between the container and fuel tank. This will prevent a spark from being generated as fuel flows over the metallic surfaces.
4. When filling fuel tank, do not smoke or use an open flame in the vicinity.
5. Always use a lifting device of more than adequate capacity when lifting or moving the engine.

### B. PROCEDURE

Use extreme care when unpacking the unit to avoid damage to engine parts and accessories.

For your protection, make a thorough inspection of the engine immediately upon delivery. In case of damage or shortage, have the carrier make a notation on the freight bill, and notify the transit agent at once.

Install the engine in a clean, well-ventilated area where it will be accessible for inspection, maintenance, and repair. The foundation must be of ample size and strength to support the unit and assure its accurate alignment with equipment to which it will furnish power.

Before starting the engine, the operator should fully understand the use and function of the operating controls and instruments.

After the engine is installed and before starting it, perform the operations listed below.

1. Remove all tape and shipping caps used to seal the engine openings.
2. Check the radiator for damage and for proper cooling capacity. Remove any foreign material that has collected on the radiator which would obstruct the flow of air past the fins and through the air passages.
3. If the cooling system drain plugs have been removed and wired to the engine, install them properly. Fill the system with coolant (refer to Topic 11).

4. Open the inlet and outlet valves to the coolant system conditioner (refer to Topic 11).
5. Make certain all air cleaner connections are tight and the filter element is installed.
6. If an oil bath type air cleaner is applied to the engine, fill the oil cup with grade of oil and to level specified by the instruction plate on the air cleaner.
7. Engine are shipped from the factory without lubricating oil (dry) or with lubricating oil (wet) depending upon whether or not oil is specified on the engine purchase order.

If engine is ordered without oil, add oil to the oil pan following the procedure in TOPIC 13, LUBRICATION SYSTEM using a quality oil of the classification specified in TOPIC 6, LUBRICATION RECOMMENDATION.

If engine is ordered with oil in the oil pan, check oil level with the side of the dipstick stamped ADD, FULL, and STOPPED before initial start of engine.

NOTE: Engine shipped wet have CD (Service DS-Series 3), SAE 20 weight lubricating oil. Maintain proper oil pan level with any good quality CD (Service DS) oil. The factory oil is compatible with any CD (Service DS) oil supplied by any major oil company. At the first regular oil change period, drain factory oil and fill with proper classification and SAE weight of oil for the prevailing atmospheric temperature. (Refer to Topic 6).

8. Check the engine drive belts for correct adjustment. The deflection should be .25 in (6.35 mm) to .50 in (12.70 mm) at midpoint on the belts. Refer to Topic 11.
9. Connect the storage batteries to the electrical system. Refer to Topic 2, Paragraph F. for ground polarity.
10. Fill the fuel tank with the recommended fuel. Refer to Topic 7.
11. If applicable, connect the fuel supply line from the fuel tank to the inlet of the fuel system. Connect the overflow line to the top of the fuel tank. If fuel injection pump is equipped with an optional hydraulic governor (Roosa

Master), the fuel leakage from the end of the accumulator must be piped to the fuel tank via a separate return line. (Refer to Fig 1 in Topic 12.)

CAUTION: Do not plug the stop screw end of the accumulator.

12. If fuel injection pump has both the electric solenoid and the manual shutoff, wire the manual shutoff lever in the RUN position when it is not required.
13. Bar the engine over by hand to make certain it turns freely.

CAUTION: Any muffler installations or exhaust pipe extensions from the manifold or turbocharger outlet must be adequately supported and flexibly connected to eliminate any possibility of strain on either the manifold or the turbocharger outlet. Total restriction for the exhaust system must not exceed the specified number of inches of mercury listed in Topic 2, Paragraph A. This test is made with the engine running under full load, full speed conditions. Refer to Topic 16 for the procedure to make this test.

14. Check engine intake and exhaust systems to make certain they are unobstructed by foreign material. The exhaust line should not be restricted by sharp bends/ crimps but should be kept as short as possible and installed with a minimum number of elbows.

## TOPIC 4. OPERATING CONTROLS AND INSTRUMENTS

### A. GENERAL

Various controls and instruments are supplied by the generator set manufacture to assist the operator to monitor and operate the equip-

ment and the engine. The operator must become familiar with the function of the controls and instruments provided for operating the unit. Refer to the generator set operating and maintenance manual for this information.

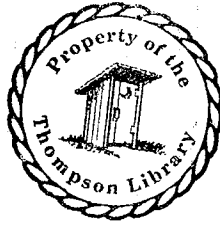

## TOPIC 5. OPERATING INSTRUCTIONS

### A. GENERAL

Before initial startup of the diesel engine complete the procedures detailed in Topic 3, PREPARATION OF ENGINE FOR OPERATION. Refer to your OWNERS MANUAL for instructions on operating the unit.

### B. OPERATING PRECAUTIONS

1. Do not operate the engine without having the air cleaner filter element installed.
2. Always allow the engine to warm up at reduced speed without load.
3. Keep the engine and accessories clean; inspect the engine while cleaning.
4. If the engine overheats due to lack of coolant, replenish slowly while engine is running.
5. Do not allow the engine to idle for prolonged periods except in cold weather below 0°F (255 K).
6. Refuel at the end of daily operation to keep condensation to a minimum.
7. In extreme cold weather optional ether starting aids or immersion heaters are available.

**CAUTION:** To prevent damage to the starting motor, do not crank engine for more than 30 seconds without a pause of 2 minutes to allow it to cool.

### C. STARTING AND STOPPING ENGINE

Refer to the generator set operating and maintenance manual for procedure to start and stop the engine.

If engine is equipped with an optional equipment ether starting aid (manually operated generator sets only), refer to TOPIC 20, titled Cold Weather Starting Aid, for procedure to start engine.

### D. DURING OPERATION CHECKS

1. Observe general condition of unit while it is running.
2. Look for loose bolts, leaks, and overheated assemblies.
3. Listen for unusual noise.
4. Stop engine and make necessary repairs and adjustments.

### E. COLD WEATHER OPERATION

1. Make certain battery is fully charged and all other electrical equipment is in optimum operating condition.
2. Use a permanent type antifreeze solution to protect engine from damage by freezing. Refer to instructions on Protection Charts furnished by antifreeze manufacturer for quantity of antifreeze required for lowest anticipated temperature.
3. Provide radiator cover if thermostat proves inadequate to maintain normal coolant operating temperature.

**CAUTION:** Do not leave engine running unattended while radiator is covered. Overheating and damage may result.

4. At end of daily operation, drain water from fuel tank.
5. When the ambient temperature is -20°F (244 K) or lower, warming the engine and battery is recommended in order to obtain satisfactory starting and to prevent engine damage. Consult your dealer for information regarding availability of special cold weather equipment. Immersion heater kits and ether base fluid starting aid kits are available.

### F. HOT WEATHER OPERATION

1. Keep cooling system filled with clean water that is low in chemical impurities.
2. Make certain that fins and passages of radiator are free of foreign material.
3. Keep external surface of engine clean.

### G. EXERCISE OF ENGINE ON STANDBY SERVICE

**NOTE:** It is recommended that standby Diesel Electric Systems be equipped with an optional rectifier type battery charger.

Under optimum conditions, a diesel engine on standby service should be exercised at least every 30 days. However, under environmental conditions including extreme temperatures, humidity, dust, sand, etc., it may be found necessary to shorten the interval between exercise periods to as often as weekly.

Exercise periods should be long enough to enable the engine to attain normal operating temperature while carrying, if possible, at least 50 percent of its normal load. To exercise engine proceed as follows:

1. Before starting engine check lubricating oil and coolant levels. Make complete visual inspection of unit to be sure that it is in operating condition.
2. Start engine and run 5 minutes with no load.
3. Run engine at rated speed with whatever load is available up to full load, for the period of time required to obtain two consecutive water temperature readings of 160°F (344 K) minimum, taken at 15 minute intervals. Continue to operate engine for 40 minutes. Check and correct any coolant or oil leaks.

**CAUTION:** If no load or a very light load must be used during exercise period cover the radiator to hasten the warmup period, but do not leave the unit unattended. Overheating and damage may result.

4. Run engine with no load for 5 minutes to allow combustion chamber temperature to decrease gradually to a minimum.
5. Stop engine.

**NOTE:** If the accumulated hours of operation during the above exercise periods is less than 100 hours (recommended lube, filter, and lubricating oil change periods) during the 6 months period, it is recommended that the lubricating oil and filter be changed every 6 months or sooner. If the accumulated hours of operation during the exercise periods is less than 600 hours (recommended fuel filter change period) during the 12 months period, it is recommended that the fuel filter element be replaced at the end of the 12 months period.

## H. ENGINE STORAGE

### 1. General

An engine stored for an extended period of time must be protected from corrosion and deterioration. The following preventive measures should be adhered to promptly after the engine is shut down. Store the engine in an enclosed moisture-free building that is heated

during the winter months. If a building is not available, cover the engine with a waterproof tarpaulin or a durable plastic cover that is tied securely to the engine.

An engine prepared for storage in one of the following manners can be returned to service at any time and within a minimum amount of time.

### 2. 30 Days Or Less Storage Period

For protection during a temporary period (30 days or less), follow the instructions indicated below:

- a. Drain engine oil pan. Fill oil pan with new lubricating oil of proper classification and SAE weight.
- b. Service the air cleaner.
- c. Drain water and sediment from fuel filters and fuel tank.
- d. If a temperature below 32°F (273 K) is expected, add a permanent type antifreeze to the cooling system.
- e. Clean exterior of engine and dry it thoroughly.
- f. Service battery and cables. Make certain battery is at full charge.
- g. Use a durable water and vaporproof material and seal all engine openings.
- h. Store engine inside of a building or cover it with a waterproof material that is tied securely to the engine.

### 3. More Than 30 Days Storage Period

Engines removed from operation for an extended period (more than 30 days and not to exceed 6 months) must be prepared for storage as follows:

- a. Service the air cleaner.
- b. Check exterior of radiator. Remove any foreign matter that has collected around and between the radiator fins.
- c. Drain and flush the cooling system. If rust or scale is observed during the flushing operation, clean the system with a commercial cleaner following the manufacturers instructions.



NOTE: Close the coolant filter inlet and outlet shutoff valves before cleaning system. Do not allow a commercial cleaner to circulate through the coolant filter.

- d. Renew coolant filter element or spin-on-can type filter. Refer to Topic 11 for procedure.
- e. Fill cooling system with clean water and add a good commercial soluble oil type rust inhibitor. However, if a temperature below 32°F (273 K) is expected, add a permanent type antifreeze to the cooling system instead.
- f. Start engine and operate it with sufficient speed and load to enable the coolant temperature to reach 180° to 185°F (355 to 358 K). At this point the thermostats will open and the coolant will circulate through the entire system. Continue to operate engine for one hour.
- g. Stop engine. Remove drain plug and drain lubricating oil from pan. Remove lubricating oil filter elements and install new filter elements.
- h. Install drain plug and fill oil pan to the full mark on the dipstick with any commercial rust preventive oil (SAE 30) meeting Military Specification MIL-L-21260. Operate engine for 10 minutes and add oil to bring oil level up to the FULL mark on the dipstick.
- i. Drain water and sediment from fuel system. Install new fuel filter/elements and prime the fuel system. Then drain the fuel tank.
- j. If fuel injection nozzles have not been serviced recently, check spray pattern and opening pressure of the nozzle holder assemblies; clean and adjust if necessary. This precaution will assure the nozzle holder assemblies are ready for operation when the engine is put back into service.
- k. Disconnect the fuel tank to primary fuel filter supply line and the fuel return line at the fuel tank. Using two clean containers, fill one with regular fuel oil and fill the other with a fuel oil containing a rust preventative such as The Texas Company "564 Rust Proofing Oil" or an equivalent.
- l. Start engine using the container with the regular fuel oil. After engine is running smoothly, switch the fuel supply line to the second container. Continue to operate engine until the rust preventive fuel oil is observed at outlet of the overflow line; then stop the engine.
- m. Connect fuel supply line and return line to fuel tank.
- n. Clean exterior of engine and dry it thoroughly.
- o. In the event the engine is to be stored outside and uncovered, it is recommended the following steps be taken to guard against excessive rusting of the crankshaft pulley grooves, due to moisture being trapped between the bottom of the pulley and the belts. This could result in increased belt wear when the engine again resumes its normal day to day usage and can be more serious when cog type belts are used.
  - (1) With the engine stopped, paint the exposed portion of the crankshaft with a fast drying paint; spray painting is acceptable.
  - (2) After the paint is thoroughly dry, bar the engine over part way and again paint the exposed portion of the pulley.
  - (3) Continue this procedure until all grooves of the crankshaft pulley are painted a full 360°.
- p. Use a durable water and vaporproof material and seal all engine openings.
- q. Disconnect battery from engine. Clean battery and battery cables. Add distilled water to bring electrolyte up to the proper level. Charge battery to make certain it is fully charged. Store battery in a cool, dry location shielded from direct sunlight and away from heat duct outlets. Do not stack a battery on top of another. Check electrolyte level and specific gravity every 30 days. Add distilled water and charge battery to maintain it in full operational condition.
- r. Store engine inside of a building or cover it with a waterproof material that is tied securely to the engine.

NOTE: The engine should be tagged indicating a certain storage manner has been performed. It should also be noted on the tag the importance of performing detailed

NOTE (cont): procedure before returning engine to service.

#### 4. More Than 6 Months Storage Period

An engine removed from operation for an extended period of more than 6 months must be prepared for storage as detailed in the preceding Subparagraph 3. Then after every 6 months of storage, perform the following:

- a. Check fuel tank for condensation and drain if necessary.
- b. Drain water from fuel filters.
- c. Fill supply tank with a sufficient amount of rust preventive fuel oil such as The Texas Company "564 Rust Proofing Oil" or an equivalent in order to exercise engine.

CAUTION: Do not allow engine to run out of fuel during exercise period.

- d. Check radiator or expansion tank coolant level and add coolant if necessary.
- e. Loosen but do not remove oil pan drain plug to drain any moisture that may have collected. When oil free of moisture appears, tighten oil pan drain plug.
- f. Remove material that was used to seal engine openings.
- g. Connect the storage battery observing correct polarity.

CAUTION: If engine is operated inside of a building, pipe the exhaust gases to the outside.

- h. Start engine and run 15 minutes at 1/2 speed.
- i. Run engine at full speed with whatever load is available up to full load for a period of time that is required to obtain two consecutive water temperature readings (minimum 160°F (344 K) that are the same when taken at a 15 minute interval. Then continue to operate engine for 30 minutes. Check and correct any coolant or oil leaks.

If no load or very light load must be used during exercise period, it is recommended the radiator (if appli-

cable) be covered on an attended engine to hasten the warm-up period.

- j. Run engine at 1/2 speed with no-load for 5 minutes before stopping to reduce combustion chamber temperatures to a minimum.
- k. Stop the engine.
- l. Disconnect the storage battery and store it as detailed in the preceding Subparagraph 3.
- m. Drain the fuel tank.
- n. Use a durable water and vaporproof material and seal all engine openings.
- o. Again store engine inside of a building or cover it with a waterproof material that is tied securely to the engine.

#### 5. Returning Engine To Service

After an engine has been in storage for an extended period up to 6 months and before returning it to service, perform the following:

- a. Check fuel tank for condensation and drain if necessary.
- b. Drain water from fuel filters.
- c. Fill fuel supply tank with specified fuel. Prime the fuel system.
- d. Remove oil pan drain plug and drain rust preventive lubricating oil.
- e. Install drain plug and fill oil pan with proper classification and SAE weight of lube oil to proper level.
- f. Open coolant filter inlet and outlet shutoff valves.

NOTE: If a soluble oil type rust inhibitor was added to the cooling system before engine was stored, drain and flush the cooling system before opening the coolant filter inlet and outlet shutoff valves.

- g. Check radiator or expansion tank coolant level and add coolant if necessary.
- h. Check condition of drive belts. Adjust or replace if necessary.

i. Remove material that was used to seal engine openings.

j. Connect the storage battery observing correct polarity.

8

## TOPIC 6. LUBRICATION RECOMMENDATIONS

### A. ENGINE LUBRICATING OIL

The general recommendation is to use CD lubricating oil in all turbocharged engines in all applications. This also applies to naturally aspirated (non-turbocharged) engines that are operating under severe applications or when the fuel sulphur content exceeds 0.5%. In most normal duty applications of non-turbocharged engines a CC grade oil can be used.

NOTE: API classification CD was formerly DS, Series 3 (MIL-L-45199B) and CC was DM (MIL-L-2140B/45199).

Allis-Chalmers diesel engines are designed for optimum performance, life and lubricating oil control, at normal operating speeds, loads and temperature, with SAE 30 viscosity lubricating oil.

Lighter viscosity oils are required for satisfactory engine starting, without damage from marginal lubrication, when crankcase temperatures during engine starting are below 32°F. (273 K). This is the only reason for the use of lubricating oils lighter than SAE 30 in Allis-Chalmers engines.

| Crankcase Temperature<br>When Starting Engine | Weight (Viscosity) |
|---|--------------------|
| 0°F and below (255 K).....                    | SAE 10W            |
| 0°F to 32°F (255 to 273 K).....               | SAE 20/20W         |
| Above 32°F (273 K).....                       | SAE 30W            |

The use of multigrade lubricating oils in Allis-Chalmers diesel engines is not recommended.

The general recommendation is to change the lubricating oil every 100 hours. When engine is equipped with a Model 750C Luber-Finer bypass filter, new filter elements must be installed at each change period. This change period is based on the use of high quality oils, fuels with less than .5% sulphur, and average engine loads not exceeding the continuous rating with engines in good adjustment and operating with coolant and lubricating oil temperatures between 170°F (350 K) to 200°F (366 K).

Variations from these considered normal operating conditions must be compensated for by more frequent oil change and/or filter change periods. Our recommendations for oil change periods are further based on what experience has shown to be conservative and safe hours of operation between oil changes.

The quality and type of the oils and additive compounds used, and the additive quantity in

various brands of lubricating oils affect their performance level. Under severe operating conditions, with engines in poor mechanical condition or when using high sulphur fuels, lubricating oils will deteriorate at a faster rate. For these reasons oil change periods can vary.

After 100 hours of operation, actual tests of the lubricating oil at an interval of 10 to 20 hours should be made. As a result of these tests the oil condition can be determined, which may either allow extended or necessitate shortening of oil and oil filter change periods. Most major lubricant suppliers provide this oil testing service on a gratis basis. We recommend that our customers take advantage of this service, not only for the protection of the engines but also to realize maximum safe usage from the lubricating oil.

Most manufacturers of lubricants recognize the importance of the quality required for use in Allis-Chalmers engines and are cooperating fully to assure the use of only those oils which fulfill these requirements. The oil distributor and oil manufacturer are to be held responsible for the results obtained from their products. Acquire your lubricants from manufacturers and suppliers with unquestioned integrity supplying known and tested products. Do not jeopardize your engine with inferior lubricating oils.

Field experience has shown that Allis-Chalmers diesel engines, in the majority of applications and under most service conditions, will perform equally well on either high ash or low ash CD lubricating oils. Our laboratory tests, however, have shown that under severe duty conditions (extended operation under full throttle conditions, high ambient temperatures, etc.) and oil having a sulfated ash level of at least 1.5% will usually outperform an oil having a lower ash level. Where a choice in lubricating oils is practical and economical, a high ash oil should therefore be selected for such applications.

Optimum oil life and also optimum engine life can be realized if the following items are given proper consideration.

1. Use of quality fuels meeting our published specifications.
2. Use of Allis-Chalmers replacement filters.
3. Adequate turbocharger and combustion chamber cooling by running engine at a fast idle for 5 minutes before shutdown.
4. Proper attention of air cleaner service and prevention of leaks in the air intake system.

5. Engine Adjustment:

- a. Correct fuel settings
  - b. Fuel injection pump timing
  - c. Injection nozzle function and opening pressure.
  - d. Valve clearance settings.
6. Cleanliness with lubricating oil, oil containers, oil storage facilities, and oil fill caps and pipes on engines.
7. Proper attention to entire cooling system including removal of antifreeze and flushing system for summer operation, maintaining specified operating temperature, maintaining fan belts and water pump drive belts in correct adjustment, and keeping radiator surfaces free of debris.

B. GREASE

1. Pressure Gun Lubricant

Use a ball and roller bearing lubricant that has a minimum melting point of 300°F (422 K). It must be waterproof

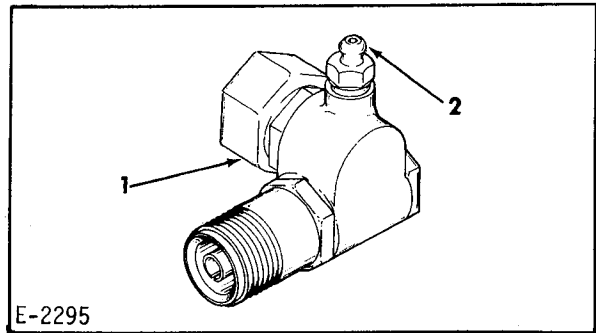

1. Angle adaptor
2. Grease fitting

Figure 1. Angle Adaptor

and have a viscosity that assures easy handling in a hand operated pressure gun at prevailing ambient temperatures.

2. Angle Adaptor Lubrication

The angle adaptor is equipped with a grease fitting for low pressure greasing every 600 hours. Lubricate with grease conforming to MIL-G-10924, or equivalent. Do not overgrease.

## TOPIC 7. FUEL OIL RECOMMENDATIONS

### A. GENERAL

Using any given grade of fuel oil, Allis-Chalmers engines perform as well as, or better than other diesel engines of comparable size and rating. However, from the standpoints of fuel economy and availability, as well as engine performance, maintenance and environmental control requirements, experience has shown that the fuel best suited for these engines closely approximates the fuel oil specification listed below.

This specification is within the American Society for Testing Materials (ASTM) specification for No. 1 and No. 2 fuels. The American Society for Testing Materials has established fuel oil specifications and testing methods to which the petroleum industry conforms very closely. Diesel engine manufacturers have, over the years, come to rely on the ASTM specifications as a standard of the industry and a simple means for the engine owner to identify and purchase fuel oil.

#### Fuel Oil Specification:

|  |                         |
|--|-------------------------|
| Gravity, API Degrees.....                                  | 30-40                   |
| Cetane Number.....   | 40 Min                  |
| Viscosity, Kinematic,<br>Centistokes @ 100° F (311 K)..... | 1.4-5.8                 |
| Flash Point.....   | 100° F (311 K) or Legal |
| Pour Point 10° F (6 K).....                                | Below Ambient Temp      |
| Distillation Temp 90% Point 640° F (611 K) Max             |                         |
| Ash % by Weight.....                                       | 0.02 Max                |
| Water and Sediment % by Volume.....                        | 0.10 Max                |
| Sulfur Content % by Weight.....                            | 0.5 Max                 |
| Carbon Residue on 10% Ramsbottom....                       | 0.35 Max                |
| Copper Strip Corrosion.....                                | No. 3 Max               |

These specifications are offered as a guide to help the diesel engine owner/operator make a satisfactory selection from the most available stocks of fuel oil. Such factors as climate, economy, and availability of fuel may at times necessitate the use of fuel with certain specifications which are outside those listed in the table.

In general the design of the Allis-Chalmers engines has been developed to take advantage of the higher energy content and generally lower cost of the No. 2 diesel fuels.

Using fuel oils that do not meet the complete specification will require shortening the filter renewal and inspection intervals to obtain a reasonable useful life from the injection equipment.

### B. FUEL OIL CHARACTERISTICS

It is not within the scope of this topic to set down all diesel fuel characteristics and the details of all testing methods, but on occasion it is necessary that the engine operator, and particularly, the person responsible for buying diesel fuel, have a working knowledge of the subject.

#### 1. API Gravity

The API gravity rating is an index of the fuel's density or weight per unit volume. In addition, it affords an indication of the viscosity, distillation characteristics and heating value of a fuel. Since fuel is purchased on a volume basis, gravity is used when setting up purchasing specs and in delivery inspections. Low API (heavier) fuels are desirable because they contain more BTU's per gallon but if they are too heavy, combustion may be incomplete.

Data extracted from a typical table based on degrees API at 60° F (289 K) is listed in the table at the bottom of this page (Figure 1).

#### 2. Cetane Number

The cetane number indicates the ignition quality of fuel oil, a critical factor in both ease of starting and smooth operation of a diesel engine. The higher the cetane number, the higher the ignition quality of the fuel.

#### 3. Viscosity

The viscosity rating of fuel oil is a measure of its resistance to flow due to the friction that exists within the oil itself. It must have the proper body or viscosity to work properly in the fuel

| Degrees API At 60° F (289 K) | Specific Gravity At 60° F (289 K) | Pounds Per Gallon At 60° F | Kilogram Per Liter At 289 K | Gallons Per Pound At 60° F | Liter Per Kilogram At 289 K | BTU Per Pound | Kilogram Joule Per Liter | BTU Per Gallon | Kilogram Joule Per Liter |
|------------------------------|-----------------------------------|----------------------------|-----------------------------|----------------------------|-----------------------------|---------------|--------------------------|----------------|--------------------------|
| 30                           | .8762                             | 7.296                      | .876                        | .1371                      | 1.1413                      | 19,420        | 45 171                   | 141,800        | 39 522                   |
| 35                           | .8498                             | 7.076                      | .850                        | .1413                      | 1.1767                      | 19,590        | 45 566                   | 138,800        | 38 686                   |
| 40                           | .8251                             | 6.870                      | .825                        | .1456                      | 1.2120                      | 19,750        | 45 938                   | 135,800        | 37 850                   |

injection system. A fuel oil of high viscosity, i.e., a "heavy" fuel oil, may cause extremely high pressures in the fuel injection system and reduce the atomization and vaporization of the fuel spray, whereas a fuel of extremely low viscosity may not provide sufficient lubrication for the close fitting pump and injector plungers, a condition which may cause abnormal wear and permit excessive leakage past the plungers.

#### 4. Flash Point

The flash point of a fuel is the temperature at which vapors in a standard testing apparatus are ignited by a small flame. Although the flash point rating has no quality significance, it is important with respect to safety in storing, shipping, and handling. Many states and insurance companies have mandatory flash point limitations and these must be considered when ordering fuel.

#### 5. Pour Point

The pour point of fuel is the lowest temperature at which it will flow or can be pumped through the fuel injection system. In equipment operating in cold ambient temperatures, the pour point must be at least 10° F (261 K) below the lowest temperature expected in order to assure satisfactory transfer and flow of fuel throughout the system.

#### 6. Distillation Temperature, 90° F (305 K) Point

The distillation temperature of fuel is a direct indication of its volatility and vaporization characteristics. Fuel can be completely burned in an engine only in vaporized form. Fuel that cannot be completely vaporized and burned will form sludge and other harmful deposits in the engine. Low distillation fuels will give more satisfactory performance and better economy when used in engines that operate periodically in cold ambient temperatures or at reduced speeds and loads, and in engines that normally operate under varying conditions of speed and load.

#### 7. Ash

Fuel oil contains measurable amounts of non-burnable, ash-forming materials in the form of abrasive solids and soluble metallic soaps. These materials tend to form harmful deposits in the engine and accelerate wear of fuel injection equipment, pistons, rings, sleeves, etc.

#### 8. Water and Sediment

Water and sediment in fuel oil promotes

wear of fuel injection equipment and other engine parts. In addition, these contaminants contribute to sludge formation and shorter fuel filter life.

#### 9. Sulfur

Sulfur in fuel oil has a marked effect on wear of engine parts and causes an increase in harmful engine deposits. Under conditions of low ambient temperatures and intermittent engine operation, condensation occurs within the engine and combines with the sulfur to form sulfurous acid ( $H_2SO_3$ ), which is highly corrosive to engine parts. The sulfur content should be kept to a minimum in order to increase the intervals between oil changes and engine overhauls.

#### 10. Carbon Residue

This specification indicates the amount of carbon deposit formed by a petroleum oil under coking conditions. Carbon residue is thought to be related to engine deposits and thoroughness of combustion.

#### 11. Copper Strip Corrosion

The corrosive tendency of a particular fuel oil is determined by immersing a copper test strip in the oil and, after following a prescribed procedure, comparing the resultant corrosion with a standard color chart.

### C. HANDLING AND STORAGE OF FUEL OIL

Improper handling and storage practices cause a major portion of all fuel system troubles. The interval between receipt of the fuel from the distributor and its final use in the engine is critical to proper functioning of the engine. The following information should be kept in mind and used as a check list from time to time in order to maintain a trouble-free fuel system.

1. Take all precautions necessary to prevent the entrance of dirt and moisture into the fuel system. Contamination by these materials accelerates sludge formation, clogs filters, lines, and nozzles, and causes abnormal wear of close fitting parts in the fuel injection pump.
2. Moisture does not accumulate as rapidly in underground storage tanks as it does in above-ground tanks because temperature is more stable.
3. Alternately cooling and heating of above-ground tanks causes condensate to accumulate rapidly. Such tanks should be placed at an angle to horizontal and be equipped with a draincock valve at the lowest point. Condensation and sediment should be drained at regular intervals.



4. Large storage tanks should be equipped with covered manholes, and small tanks should be provided with ports and removable covers in order to facilitate tank cleaning.
5. Fuel fill pipe should extend above ground level and be equipped with a watertight, dustproof cap or cover.
6. Tanks should be vented to a safe area to allow normal "breathing" caused by expansion and contraction of the fuel and air.
7. The fuel outlet line should be connected to the tank either at the end opposite the sediment collection point or at a point that is well above the area of maximum accumulation.
8. Fuel lines should be of aluminum or steel wherever possible. Copper accelerates deterioration of fuel and induces sludge and gel formation.
9. All fuel handling equipment, such as funnels, hand pumps, and dipsticks, should be kept clean at all times and covered when not in use.
10. Do not open fuel containers or transfer fuel from drums to tanks in areas exposed to blowing dust and dirt. Also, do not use cotton waste material or linty rags to wipe containers, funnels, hand pumps, dipsticks, etc.
11. All fuel oils deteriorate at different rates depending upon such factors as the original source of the crude oil, the extent of refining and blending it has undergone, the degree of contamination introduced during storage, and age of the fuel oil.
  - a. Do not use tanks of larger capacity than necessary. The maximum recommended storage period for current type diesel fuels composed of blends of straight run distillates and catalytically cracked stocks is 6 months to one year. The user is inviting clogged filters and fuel injection difficulties if fuel is used that has been stored for longer periods. When longer storage periods are anticipated, a stabilizing additive should be specified when the fuel is ordered. Regardless of storage time, a full tank is preferable to one that is only partially filled.
  - b. Fuel instability is related in some degree to its sulfur content. Sulfur promotes the formation of corrosive compounds that are very destructive to metals in the fuel storage and fuel injection system.
  - c. Do not continually add new fuel to old fuel in storage without occasionally draining and disposing of all fuel remaining in the tank. The chemical change already started in the old fuel accelerates deterioration of the new fuel.

8

## TOPIC 8. LUBRICATION AND MAINTENANCE SCHEDULE, AND MAINTENANCE TOOLS

### A. GENERAL

Maintenance includes those functions and activities that will keep the engine in peak operating condition and prevent unnecessary trouble from developing.

Lubrication is an essential part of the maintenance program controlling to a great extent the useful life of the engine. It is important that the instructions regarding the types of lubricant (Topic 6) be closely followed. The lubrication intervals given in the schedule are based on normal engine operation, using the recommended oil and filters. This maintenance schedule is designed to be used as a guide until adequate data has been acquired to establish a schedule to fit a specific operation. Actual tests of the lubricant should be made to increase or decrease the interval as the actual condition of the oil may dictate.

In addition to lubrication, the schedule specifies other maintenance functions that must be performed at prescribed intervals. These intervals are based on normal operation, alter the interval length to suit your particular operating conditions.

Thoroughly clean all lubrication fittings, caps, filter and level plugs, and the surrounding surfaces before servicing the engine. Prevent dirt or other contaminants from entering the lubricants and coolants.

For detailed information regarding the lubrication, inspection or service procedure of any given components, refer to the applicable topic in this manual.

NOTE: The environment and load conditions to which engines are subjected can considerably lengthen or shorten the intervals they will efficiently operate between valve reconditioning, piston ring replacement, and complete overhaul. Observation of crankcase breathing, exhaust sound and color, lubricating oil consumption, engine power, and the sound of the engine in operation by a qualified diesel mechanic will determine the need for reconditioning.

### B. LUBRICATION AND MAINTENANCE GUIDE

Checks should be made at the intervals shown (hours or months) whichever occurs first.

Generally the hours listed in the following guide are for prime power units and the months for standby units.

| 1. Daily/Each 8 Hours/At Time Standby Unit is Exercised  |           |           |
|--|-----------|-----------|
| Description  | Reference |           |
|  | Topic     | Paragraph |
| <b>a. Before Starting Engine</b>   |           |           |
| (1) Visually inspect belts and hoses for deterioration, also engine and accessories for signs of fuel, lubricant, coolant, air or exhaust leaks. Make corrections as required. |           |           |
| (2) Check/correct coolant level.   | 11        | F         |
| (3) Check oil level with side of dipstick marked STOPPED to assure safe level for starting engine.   | 13        | B         |
| (4) Drain water from fuel tank.  | 12        | A         |
| (5) If applicable, drain water from fuel water separator.  | 12        | D         |
| (6) Check air cleaner restriction indicator. Replace air cleaner element if red indicator is visible.  | 17        | C         |
| (7) Check/correct air cleaner to turbo loose clamps or deteriorated hoses.   | 18        | D         |
| <b>b. Start Engine</b>   |           |           |
| (1) Check/correct starter performance  | 14        | D         |
| (2) Check/correct oil pressure   | 13        | A-G       |
| (3) Check/correct alternator charging rate.  | 14        | E-F       |
| <b>c. After Engine Reaches Operating Temperature</b>   |           |           |
| (1) If applicable, check engine oil level at idle speed. Maintain between running ADD and FULL level marks on dipstick.  | 13        | B         |
| (2) Observe the following for normal operation:  |           |           |
| (a) Coolant temperature  | 11        | I         |
| (b) Lube oil pressure  | 13        | A-G       |
| (c) Idle/full load speed   | 12        | G         |
| (d) Air cleaner service indicator  | 17        | C         |
| (3) Check/correct for knocks other unusual noises.   | 9         | B         |

| 2. Each 100 Hours/6 Months  |           |            |
|---|-----------|------------|
| Description   | Reference |            |
|   | Topic     | Para-graph |
| a. Check/correct radiator for external cleanliness and restriction of air through fins. | 11        | G          |
| b. Make initial replacement of coolant filter.  | 11        | K          |
| c. Change engine lubricating oil.   | 13        | E          |
| d. Renew lubricating fullflow oil filter.   | 13        | C          |
| e. If applicable renew bypass lubricating oil filter.                                   | 13        | D          |
| f. Check/correct liquid level of battery cells.   | 14        | C          |
| g. Check/correct leaks<br>(1) Lube oil (4) Air<br>(2) Fuel (5) Exhaust<br>(3) Coolant   |           |            |
| h. Using engine oil, lubricate throttle/stop control swivels.                           |           |            |

| 4. Each 1300 Hours/24 Months  |           |            |
|---|-----------|------------|
| Description   | Reference |            |
|   | Topic     | Para-graph |
| a. Inspect/correct nozzle holder opening pressure and nozzle spray pattern.                                 | 12        | K          |
| b. Check specific gravity of battery fluid.   | 14        | C          |
| c. Inspect/clean/tighten electrical connections:<br>(1) Battery (3) Alternator<br>(2) Starter (4) Regulator | 14        | C-E<br>D-F |
| d. Check/tighten exhaust and intake manifold fasteners.   | 16        | B          |
| e. Check/tighten engine mounting fasteners.   |           |            |
| f. Inspect and clean nozzle hole in the starting aid.   | 20        | E          |

| 3. Each 600 Hours/12 Months  |           |            |
|--|-----------|------------|
| Description  | Reference |            |
|  | Topic     | Para-graph |
| a. Renew fuel filter.  | 12        | B-C        |
| b. Renew coolant filter.   | 11        | K          |
| c. Check tension and condition of alternator and water pump drive belts. | 11        | J          |
| d. Check/clean engine breather tube.                                     | 13        | G          |
| e. Check/correct turbocharger for loose mounting nuts and piping.        | 18        | D          |

| 5. Each 2600 Hours  |                |            |
|---|----------------|------------|
| Description   | Reference      |            |
|   | Topic          | Para-graph |
| a. Recondition nozzle-holder assemblies.  | 12             | K          |
| b. Recondition intake and exhaust valves and seats.   | SERVICE MANUAL |            |
| c. Check/correct cylinder sleeve bores for excessive wear.  | SERVICE MANUAL |            |
| d. Check/correct turbocharger:<br>(1) Wheels for dirt and carbon<br>(2) Bearing clearance<br>(3) Shaft endplay. | 18             | E          |
| e. Clean exterior of engine and radiator.   |                |            |

| 6. Each 5200 Hours   |           |            |
|--|-----------|------------|
| Description  | Reference |            |
|  | Topic     | Para-graph |
| a. Make major inspection of engine. Repair or replace parts with excessive wear. |           |            |

C. MAINTENANCE TOOLS

The following tool listing has been prepared to assist service and maintenance personnel in the selection of tools (other than standard hand or shop tools) to accomplish the various maintenance operations described and illustrated in this manual.

The tools listed must be ordered directly from the tools manufacturer.

TOOL MANUFACTURERS

- (BI) Bacharach Instrument Company  
Division of American Bosch ARMA Corp.  
200 North Braddock Avenue  
Pittsburgh, Pennsylvania 15208
- (KM) Service Tool Division  
Kent Moore Corporation  
28635 Mound Road  
Warren, Michigan 48092
- (OTC) Owatonna Tool Company  
Owatonna, Minnesota 55060

| Topic | Figure No. | Manufacturer's Tool Number and Description |           |  |
|-------|------------|--|-----------|--|
| 9     | 1          | (KM)                                       | J-6692    | Compression Gauge Assembly                   |
| 9     | 1          | (KM)                                       | J-22472   | Compression Gauge Adaptor (Less Tip)         |
| 9     | 1          | (KM)                                       | J-21616   | Compression Gauge Adaptor Tip                |
| 12    | 5          | (OTC)                                      | 13371     | Seal Compressor - Injection Pump Drive Shaft |
| 12    | 7          | (OTC)                                      | 13366     | Advance Test Window (Plastic)                |
| 12    | 16         | (BI)                                       | 65-030D   | Nozzle Tester (Only)                         |
| 12    | 16         | (BI)                                       | 65-481    | Connector Set                                |
| 12    | 16         | (BI)                                       | 65-317    | Plastic Cup (Spray Collector)                |
| 12    | *          | (BI)                                       | 65-808    | Carrying Case                                |
| 12    | 17         | (KM)                                       | J-6999    | Injection Nozzle Holder Fixture              |
| 12    | 19         | (KM)                                       | J-4298-1  | Pin Vise                                     |
| 12    | 19         | (KM)                                       | J-7854    | Nozzle Hole Cleaning Wire                    |
| 12    | 20         | (KM)                                       | J-21609-7 | Injection Nozzle Bore Cleaner                |

\*Note Illustrated

0

## TOPIC 9. TROUBLESHOOTING

| PARAGRAPH | TITLE                         | PAGE |
|-----------|-------------------------------|------|
| A         | GENERAL.....                  | 1    |
| B         | ENGINE.....                   | 1    |
| C         | STARTING SYSTEM.....          | 4    |
| D         | FUEL SYSTEM.....              | 5    |
| E         | AIR INTAKE SYSTEM.....        | 5    |
| F         | COOLING SYSTEM.....           | 6    |
| G         | LUBRICATING SYSTEM.....       | 7    |
| H         | ELECTRICAL SYSTEM.....        | 8    |
| I         | INSTRUMENTS.....              | 9    |
| J         | LOCATING CYLINDER CUTOUT..... | 9    |
| K         | MAKING COMPRESSION CHECK..... | 9    |

### A. GENERAL

It has been proved that over 90% of the troubles that occur in engine operation are avoided when those responsible for maintenance adhere to an adequate program of lubrication, inspection, and maintenance. The time and expense involved in such programs is only a fraction of that incurred when poor maintenance practice results in a major malfunction or breakdown.

In most cases, when a trouble is detected and remedied immediately, a more expensive, time-consuming repair will be avoided. The following list of troubles, causes, and remedies is given to aid the operator in locating and correcting mechanical and electrical troubles as quickly as possible. For detailed inspection and service procedures for any given components, refer to that section or topic pertaining to the part, assembly, or system.

### B. ENGINE

| TROUBLE                | POSSIBLE CAUSES   | REMEDY  |
|------------------------|---|---|
| Engine will not crank. | <ol style="list-style-type: none"> <li>1. Batteries weak.</li> <li>2. Starting system faulty.</li> <li>3. Engine is locked or seized.</li> <br/> <li>4. Hydro-static lock.</li> </ol> | <ol style="list-style-type: none"> <li>1. Check specific gravity.</li> <li>2. Refer to Paragraph C.</li> <li>3. This can be due to extended idle or storage periods, or to improper preparation of the engine for storage, in which case the parts may be rusted or corroded and seized. Broken piston rings, gears, etc., may also cause locking. Repair or replace defective parts.</li> <li>4. Check for rain water having entered an uncovered exhaust pipe, leaking cylinder head gasket and cracked block or cylinder head. Repair or replace defective parts.</li> </ol> |
| Engine will not start. | <ol style="list-style-type: none"> <li>1. Incorrect starting procedure.</li> <li>2. Slow cranking speed.</li> <br/> <li>3. Engine controls out of adjustment.</li> </ol>              | <ol style="list-style-type: none"> <li>1. Follow correct starting procedure.</li> <li>2. Specific gravity of battery too low. Charge battery. Starter not delivering maximum torque. Repair or replace defective parts. Use cold weather starting aids if applicable.</li> <li>3. Check all engine control linkages for proper adjustment.</li> </ol>   |

| TROUBLE                        | POSSIBLE CAUSES   | REMEDY   |
|--------------------------------|---|--|
| Engine will not start (cont.). | 4. Insufficient supply of fuel to fuel injection nozzles.<br>5. Fuel injection nozzles not operating properly.<br>6. Fuel injection pump improperly timed.  | 4. Refer to Paragraph D.<br>5. Test and repair or replace nozzles<br>6. Time fuel injection pump.  |
| Engine hard to start.          | 1. Incorrect starting procedure.<br>2. Batteries weak.<br>3. Insufficient fuel in fuel tank.<br>4. Incorrect grade of fuel.<br>5. Clogged fuel filters.<br>6. Fuel injection nozzles not operating properly.<br>7. Fuel transfer pump not operating properly.<br>8. Air in fuel system.<br>9. Insufficient air supply to cylinders.<br>10. Fuel injection pump improperly timed.<br>11. Valve lash incorrect.<br>12. Piston rings or cylinder sleeves worn.<br>13. Valves warped or pitted. | 1. Follow correct starting procedure.<br>2. Recharge or replace batteries.<br>3. Check fuel level in tank. Fill with specified fuel if necessary.<br>4. Drain fuel system. Fill the tank with the specified fuel.<br>5. Replace filter elements.<br>6. Test and repair or replace nozzles.<br>7. Test and repair or replace fuel feed (transfer) pump.<br>8. Refer to Paragraph D.<br>9. Refer to Paragraph E.<br>10. Time fuel injection pump.<br>11. Adjust valve lash.<br>12. Replace affected parts.<br>13. Recondition or replace valves and/or valve guides. |
| Engine stops frequently.       | 1. Idling speed too low (not applicable to generator drive engines).<br>2. Restricted fuel supply.  | 1. Adjust low idling speed.<br>2. Check fuel system.   |
| Engine stops unexpectedly.     | 1. Out of fuel.<br>2. Restricted fuel supply.<br>3. Broken or loose fuel lines.<br>4. Fuel feed (transfer) pump or fuel injection pump inoperative.   | 1. Fill fuel tank with specified fuel and prime the fuel system.<br>2. Check fuel system.<br>3. Correct or replace affected parts.<br>4. Replace inoperative parts.  |



| TROUBLE  | POSSIBLE CAUSES   | REMEDY  |
|--|---|---|
| Engine overheats.                              | <ol style="list-style-type: none"> <li>1. Cooling system faulty.</li> <li>2. Radiator core coolant passages clogged.</li> <li>3. Radiator air passages clogged.</li> <li>4. Fan drive belts loose.</li> <li>5. Thermostats inoperative.</li> <li>6. Engine oil cooler clogged.</li> <li>7. Improper engine lubrication.</li> <li>8. Water pump malfunctioning.</li> <li>9. Fuel injection pump improperly timed.</li> </ol>   | <ol style="list-style-type: none"> <li>1. Refer to Paragraph F.</li> <li>2. Clean and flush radiator.</li> <li>3. Remove debris from radiator core.</li> <li>4. Adjust fan drive belts to proper tension.</li> <li>5. Test the thermostats for proper operation; replace if necessary.</li> <li>6. Clean or replace the oil cooler core.</li> <li>7. Refer to Paragraph G.</li> <li>8. Repair or replace the water pump.</li> <li>9. Time fuel injection pump.</li> </ol> |
| Engine shows loss of power.                    | <ol style="list-style-type: none"> <li>1. Insufficient supply of air to cylinders.</li> <li>2. Insufficient supply of fuel to fuel injection nozzles.</li> <li>3. Governor not operating properly.</li> <li>4. Air in fuel system.</li> <li>5. Clogged fuel filters.</li> <li>6. Improper valve lash.</li> <li>7. Fuel injection pump improperly timed.</li> <li>8. Inoperative fuel injection pump or fuel injection nozzles.</li> <li>9. Cylinder cutting out.</li> <li>10. Loss of compression.</li> </ol> | <ol style="list-style-type: none"> <li>1. Refer to Paragraph E.</li> <li>2. Refer to Paragraph D.</li> <li>3. Inspect and adjust governor.</li> <li>4. Refer to Paragraph D.</li> <li>5. Change filter elements.</li> <li>6. Adjust valve lash.</li> <li>7. Time fuel injection pump.</li> <li>8. Repair or replace affected parts.</li> <li>9. Refer to Paragraph J.</li> <li>10. Refer to Paragraph K.</li> </ol>   |
| Engine runs unevenly with excessive vibration. | <ol style="list-style-type: none"> <li>1. Governor not operating properly.</li> <li>2. Fuel supply erratic or insufficient.</li> <li>3. Engine operating temperature too low.</li> <li>4. Fuel injection pump malfunctions.</li> <li>5. Valves in bad condition.</li> </ol>   | <ol style="list-style-type: none"> <li>1. Remove fuel injection pump and make necessary repairs to governor.</li> <li>2. Refer to Paragraph D.</li> <li>3. Refer to Paragraph F.</li> <li>4. Check fuel injection pump.</li> <li>5. Recondition valves.</li> </ol>  |

| TROUBLE   | POSSIBLE CAUSES   | REMEDY   |
|---|---|--|
| Engine runs unevenly with excessive vibration (cont).   | 6. Cylinder "cutting-out."<br>7. Fuel injection nozzle malfunctions.  | 6. Correct cause.<br>7. Repair nozzle.   |
| Engine emits black smoke from exhaust.  | 1. Air system clogged.<br>2. Fuel injection pump roller-to-roller dimension incorrect.<br>3. Improper fuel.<br>4. Lack of good fuel injection nozzle spray pattern.       | 1. Check engine air intake system.<br>2. Correct roller-to-roller dimension.<br>3. Drain fuel system and refill with specified fuel.<br>4. Clean and adjust nozzles.   |
| Engine emits bluish-white smoke from exhaust.   | 1. Engine operating temperature too low.<br>2. Fuel injection nozzle valve stuck in open position.<br>3. Low compression.<br>4. Early fuel injection pump timing.         | 1. Check thermostat.<br>2. Test and adjust nozzles.<br>3. Make compression test and necessary repairs.<br>4. Test and adjust.  |
| Engine detonates or knocks.   | 1. Fuel pump improperly timed.<br>2. Loose bearings.<br>3. Loose piston.<br>4. Loose flywheel.<br>5. Improperly adjusted valve(s).<br>6. Foreign material in cylinder(s). | 1. Check and adjust.<br>2. Replace bearings.<br>3. Inspect piston assembly. Replace parts required.<br>4. Check tightness of flywheel bolts and dowel. Tighten/replace parts required.<br>5. Check and adjust.<br>6. Clean and make necessary repairs. |
| <p>CAUTION: If a hard metallic knock indicates detonation in one or more cylinders, the engine must be stopped immediately to prevent serious damage due to the excessive pressure accompanying the detonation.</p> |   |  |

#### C. STARTING SYSTEM

|                                |   |   |
|--------------------------------|---|---|
| Starter will not crank engine. | 1. Batteries weak.<br>2. Cables and/or connections loose or corroded.<br>3. Starter switch inoperative. | 1. Check batteries.<br>2. Tighten all loose connections and clean corrosion from all terminals.<br>3. Replace switch. |
|--------------------------------|---|---|

| TROUBLE  | POSSIBLE CAUSES   | REMEDY   |
|--|---|--|
| Engine will not crank engine (cont).                     | 4. Starter brushes worn or not contacting properly.<br>5. Starter brush springs weak.<br>6. Starter commutator dirty or worn.<br>7. Starter armature shaft bushings worn (armature drags on fields).<br>8. Starter armature burned out. | 4. Install new brushes or fit brushes to conform to contour of commutator.<br>5. Check brush spring tension; replace springs if necessary.<br>6. Polish commutator, machine commutator and under-cut mica if necessary.<br>7. Replace worn bushings and related items.<br>8. Replace armature. |
| Starter pinion will not engage with fly-wheel ring gear. | 1. Grease and/or dirt in starter drive mechanism.<br>2. Broken or excessively worn parts.   | 1. Disassemble and clean the drive assembly.<br>2. Replace broken or worn parts.   |

#### D. FUEL SYSTEM

|   |   |   |
|---|---|---|
| Insufficient fuel supply to fuel injection nozzles. | 1. No fuel in fuel tank.<br>2. Inoperative fuel feed (transfer) pump.<br>3. Fuel injection nozzle valve binding in valve body.<br>4. Clogged fuel filters, fuel lines and sediment bowl on early engines.<br>5. Fuel injection pump malfunctioning.<br>6. Fuel injection nozzles improperly adjusted. | 1. Fill fuel tank with specified fuel. Prime fuel system.<br>2. Repair or replace feed (transfer) pump.<br>3. Replace valve assembly in nozzle holder body.<br>4. Clean fuel system components, replace fuel filter elements.<br>5. Replace fuel injection pump.<br>6. Adjust fuel injection nozzles. |
| Air in Fuel system.                                 | 1. Loose fuel line fitting or leak in fuel line on suction side of fuel feed (transfer) pump.<br>2. Damaged fuel filter or gasket.  | 1. Tighten loose fitting or replace damaged line.<br>2. Replace filter.   |

#### E. AIR INTAKE SYSTEM

|                                       |  |   |
|---------------------------------------|--|---|
| Insufficient air supply to cylinders. | 1. Air cleaner clogged.<br>2. Foreign material lodged in turbocharger impeller or turbine. | 1. Replace air filter element.<br>2. Disassemble and clean. |
|---------------------------------------|--|---|

| TROUBLE                                      | POSSIBLE CAUSES   | REMEDY   |
|--|---|--|
| Insufficient air supply to cylinders (cont). | <p>3. Excessive dirt buildup in compressor or turbocharger.</p> <p>4. Excessive dirt buildup in compressor in short period of time.</p> <p>5. Leaks in engine intake and/or exhaust manifolds reducing turbocharger efficiency.</p> <p>6. Turbocharger bearings seized.</p> | <p>3. Thoroughly clean compressor assembly.</p> <p>4. Clean compressor assembly, and service air intake system for leaks.</p> <p>5. Tighten loose manifold retaining capscrews. Replace manifold gaskets.</p> <p>6. Overhaul turbocharger.</p>   |
| Rapid wear on engine parts.                  | <p>1. Dirt admitted with intake air.</p> <p>2. Dirty lubricating oil.</p> <p>3. Improper fuel.</p>  | <p>1. Inspect air cleaner body, pipe, connecting hoses, gaskets, etc., thoroughly for cracks or openings which would allow air to enter engine without passing through air cleaner. Make necessary repairs.</p> <p>2. Change engine oil and the lubricating oil filter elements at the intervals recommended. Keep oil clean when filling engine.</p> <p>3. Use the proper fuel. It is important that the fuel be within the specified limits for ash, carbon, sulfur, etc. to prevent excessive wear on engine parts.</p> |

#### F. COOLING SYSTEM

|   |  |   |
|---|--|---|
| Engine operating temperature too high, even with ample coolant in system. | <p>1. Temperature gauge inoperative.</p> <p>2. Radiator air passages restricted.</p> <p>3. Thermostats inoperative.</p> <p>4. Loose or broken fan drive belts.</p> <p>5. Lime deposits in coolant passages of radiator, cylinder heads and/or cylinder block.</p> <p>6. Coolant passages in oil cooler restricted.</p> <p>7. Water pump inoperative.</p> <p>8. Engine pulling excessive load.</p> <p>9. Engine speed set too high.</p> | <p>1. Check gauge. Replace if necessary.</p> <p>2. Clean exterior of radiator.</p> <p>3. Replace thermostats.</p> <p>4. Adjust or replace fan drive belts.</p> <p>5. Thoroughly clean affected parts.</p> <p>6. Remove and clean oil cooler core.</p> <p>7. Repair or replace water pump.</p> <p>8. Reduce load.</p> <p>9. Adjust speed to within specified rpm limits.</p> |
|---|--|---|

| TROUBLE   | POSSIBLE CAUSES   | REMEDY  |
|---|---|---|
| Engine operating temperature too high due to loss of coolant. | <ol style="list-style-type: none"> <li>1. External leaks.</li> <li>2. Ruptured oil cooler core (oil in coolant).</li> <li>3. Engine cylinder head gaskets leaking.</li> <li>4. Engine cylinder heads cracked.</li> <li>5. Engine cylinder block cracked.</li> </ol> | <ol style="list-style-type: none"> <li>1. Repair affected parts.</li> <li>2. Replace oil cooler core.</li> <li>3. Replace gaskets and torque cylinder head nuts or capscrews to specified torque.</li> <li>4. Replace cylinder head.</li> <li>5. Replace cylinder block.</li> </ol> |
| Engine operating temperature too low.                         | <ol style="list-style-type: none"> <li>1. Thermostats stuck in open position.</li> <li>2. Operating in extremely cold weather.</li> </ol>   | <ol style="list-style-type: none"> <li>1. Replace thermostats.</li> <li>2. Provide covers for radiator and engine side openings.</li> </ol>   |

#### G. LUBRICATING SYSTEM

|  |  |  |
|--|--|--|
| No lubricating oil pressure.                                   | <ol style="list-style-type: none"> <li>1. Insufficient oil.</li> <li>2. Oil Pressure gauge inoperative.</li> <li>3. Lubricating oil pump screen clogged.</li> <li>4. Lubricating oil pump inoperative.</li> <li>5. Oil lines loose or broken inside engine.</li> </ol>   | <ol style="list-style-type: none"> <li>1. Fill oil pan to proper level.</li> <li>2. Replace gauge.</li> <li>3. Remove and clean the screen.</li> <li>4. Repair or replace oil pump.</li> <li>5. Repair or replace affected parts.</li> </ol>   |
| Low lubricating oil pressure with proper oil level in oil pan. | <ol style="list-style-type: none"> <li>1. Oil pressure gauge inaccurate.</li> <li>2. Oil pressure relief valve or regulator valve stuck in open position.</li> <li>3. Oil lines loose or broken.</li> <li>4. Improper lubricant.</li> <li>5. Main and/or connecting rod bearings worn.</li> <li>6. Camshaft bearings worn.</li> <li>7. Lubricating oil pump worn.</li> </ol> | <ol style="list-style-type: none"> <li>1. Check gauge. Replace if necessary.</li> <li>2. Clean, repair, or replace affected parts.</li> <li>3. Repair or replace affected items.</li> <li>4. Fill oil pan with specified lubricant.</li> <li>5. Replace bearings.</li> <li>6. Replace bearings.</li> <li>7. Repair or replace oil pump.</li> </ol> |
| Excessive lubricating oil pressure.                            | <ol style="list-style-type: none"> <li>1. Oil pressure gauge inaccurate.</li> <li>2. Oil pressure regulating valve improperly adjusted.</li> </ol>   | <ol style="list-style-type: none"> <li>1. Check gauge. Replace if necessary.</li> <li>2. Adjust valve to obtain proper pressure.</li> </ol>  |

| TROUBLE                                    | POSSIBLE CAUSES  | REMEDY  |
|--|--|---|
| Excessive lubricating oil pressure (cont). | 3. Improper lubricant.   | 3. Fill oil pan with specified lubricant.   |
| Overheating of lubricating oil             | 1. Insufficient oil.<br>2. Improper lubricant.<br>3. Engine oil cooler clogged.  | 1. Fill oil pan to proper level.<br>2. Fill oil pan with specified lubricant.<br>3. Clean or replace the oil cooler.  |
| Excessive oil consumption.                 | 1. External oil leakage (gaskets, etc.).<br>2. Crankshaft oil seals worn or damaged.<br>3. Lubricating oil too light.<br>4. Pistons, rings, and/or cylinder sleeves worn.<br>5. Oil control rings stuck in piston ring grooves.<br>6. Valve guides worn. | 1. Correct all external leaks.<br>2. Replace oil seals.<br>3. Fill oil pan with specified lubricant.<br>4. Replace affected parts.<br>5. Clean ring grooves and replace rings.<br>6. Replace valve guides. Check related parts.   |
| Rapid wear on engine parts.                | 1. Lubricating oil contaminated.<br>2. Improper engine lubricating oil being used.<br>3. Dirt admitted with intake air.  | 1. Fill system with clean engine oil. Replace engine oil filters.<br>2. Fill system with engine lubricating oil of proper specifications.<br>3. Inspect air cleaner body, pipe, connecting hoses, gaskets, etc., thoroughly for cracks or openings which would allow air to enter engine without passing through air cleaner. Make necessary repairs. |

#### H. ELECTRICAL SYSTEM

|  |   |  |
|--|---|--|
| No output from alternator.             | 1. Drive belt loose or broken.<br>2. Regulator inoperative.<br>3. Alternator inoperative. | 1. Adjust or replace drive belt.<br>2. Remove regulator for repair or replacement.<br>3. Remove unit for repairs or replacement. |
| Alternator output low and/or unsteady. | 1. Drive belt improperly adjusted.<br>2. Regulator operating improperly.                  | 1. Adjust drive belt.<br>2. Remove regulator for repair or replacement.  |

| TROUBLE                                       | POSSIBLE CAUSES   | REMEDY  |
|---|---|---|
| Alternator output low and/or unsteady (cont). | 3. Brush spring tension too low.<br>4. Alternator circuit components damaged.   | 3. Replace brush springs.<br>4. Remove alternator for repair or replacement.  |
| Batteries will not hold charge.               | 1. Loose terminals or connections.<br>2. Short in electrical system.<br>3. Short circuit in battery.<br>4. Electrolyte level low (regulator output excessive or battery case cracked).<br>5. Regulator inoperative. | 1. Tighten affected parts.<br>2. Correct short.<br>3. Remove and repair or replace battery.<br>4. Reduce charging rate. Remove and repair or replace battery.<br>5. Remove regulator for repair or replacement. |

#### I. INSTRUMENTS

If any of the instruments/gauges fail to register proper readings while engine is in operation, the system/circuit to which the instrument applies should be thoroughly checked/ tested. If failure of the instrument is suspected, test by installing a new tested instrument. Replace any inoperative instrument.

#### J. LOCATING CYLINDER CUTOUT

**CAUTION:** The tests in Paragraph J and K require the engine to be operated at speeds below 1400 rpm. If the engine is powering a generator set, the main generator voltage regulator must be disconnected from the system to protect it from damage at the lower speeds.

Locate "missing" cylinders by following the procedure indicated below.

Run engine at low idle (500 rpm) speed and cut out each fuel injection nozzle, one at a time, by loosening the fuel injection line nut attaching line to fuel injection pump or nozzle holder assembly.

A decrease in engine speed with line nut loosened indicates nozzle for that cylinder is functioning properly. If engine speed does not decrease, nozzle is malfunctioning and must be replaced.

#### K. MAKING COMPRESSION TEST

Loss of compression may be due to leaking valves, worn piston rings, or cylinder sleeves. Using a suitable compression tester, check and

record the compression of each cylinder.

Compression pressure for a normal engine at normal operating temperature firing on five cylinders at 600 rpm and at sea level conditions is 500 psi (3447 kN/m<sup>2</sup>) (nominal).

When checking the compression pressure, the altitude at which the engine is located must

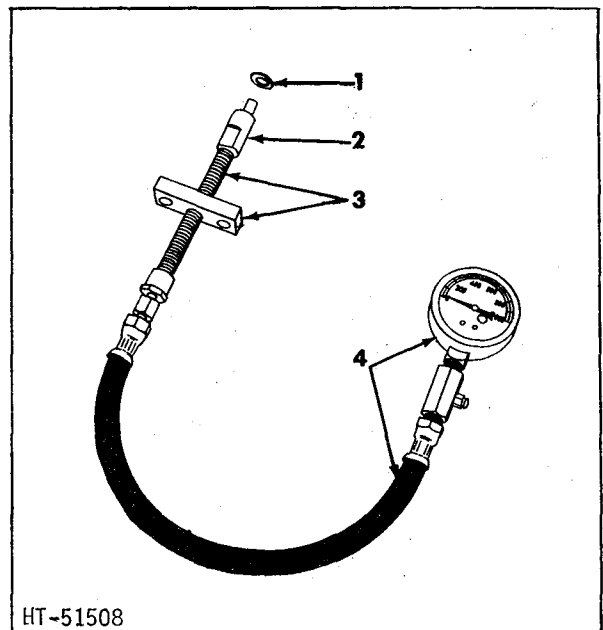

HT-51508

1. Nozzle gasket
2. Adaptor tip
3. Adaptor
4. Compression gauge assembly

Figure 1. Tools for Checking Compression

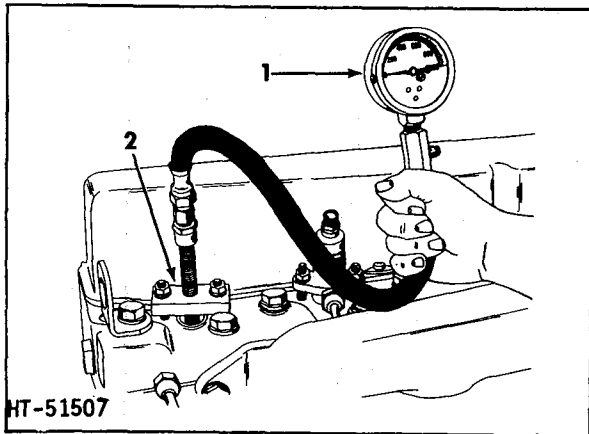

1. Compression tester gauge assembly
2. Compression tester adaptor

Figure 2. Checking Compression Pressure

be taken into consideration for an accurate evaluation of the test, because the density of air decreases as altitude increases. For each 1000 feet (304.8 m) of altitude above sea level the specified sea level figure of 500 psi (3447 kN/m<sup>2</sup>) must be derated by 3%.

It is common practice to consider a differential of 30 psi (207 kN/m<sup>2</sup>) between one or more cylinders as an indication of possible trouble. This is not always true. Pressure readings taken at 600 rpm are not always representative of what is happening within the engine at 1800 or 2000 rpm, under load. If a spread between cylinders of 30 psi (207 kN/m<sup>2</sup>) or more at 600 rpm is noted and there is no evidence of excessive oil consumption, intake or exhaust valve blow-by into the manifolds, or loss of engine power, it is safe to continue to operate the engine. However, if any of the above conditions exist or if a difference of 50 psi (345 kN/m<sup>2</sup>) or more is noted between cylinders, the cylinder heads should be removed and a detailed inspection made of cylinder heads, valves, pistons, rings, and cylinder sleeves, and necessary repairs should be made to eliminate cause of the low compression pressure.

NOTE: In order to obtain an accurate pressure indication, make certain the compression tester gauge has been properly tested and calibrated. Do not rebuild an engine because of low compression readings obtained with a compression tester unless the gauge is known to be accurate.

To check compression pressure, proceed as follows:

1. Start the engine and warm up to minimum temperature of 160°F (344 K).
2. Stop the engine. Remove drip manifold from the nozzle holder assemblies.

NOTE: To prevent spillage of fuel, when the drip manifold is removed, connect a hose to the fuel return line from the pump and replace the open end in a container to receive the overflow fuel from the injection pump while the engine is running.

3. Start with the number 1 cylinder when checking the compression. Remove the fuel injection nozzle and install the compression tester adaptor in the same manner as the fuel injection nozzle was installed. Install the compression tester hose and gauge assembly (Figure 2).
4. Start the engine, run at approximately 600 rpm, and take several readings on gauge.

NOTE: Do not check compression by cranking engine with starter.

5. Remove the tester assembly, install nozzle holder, connect fuel injection line and fuel return line.
6. Repeat the operation on each remaining cylinder.
7. Install the drip manifold.



## TOPIC 10. FITS AND TOLERANCES; BOLT, CAPSCREW, AND NUT TORQUE WRENCH SPECIFICATIONS; STUD GAUGE HEIGHTS

|  |    |
|--|----|
| A. FITS AND TOLERANCES. . . . .  | 1  |
| 1. Cylinder Sleeves. . . . .   | 1  |
| 2. Cylinder Block. . . . .   | 2  |
| 3. Pistons . . . . .   | 2  |
| 4. Piston Pins . . . . .   | 2  |
| 5. Piston Rings. . . . .   | 2  |
| 6. Crankshaft. . . . .   | 2  |
| 7. Main Bearings . . . . .   | 3  |
| 8. Connecting Rod Bearings . . . . .   | 3  |
| 9. Connecting Rods . . . . .   | 3  |
| 10. Exhaust Valves. . . . .  | 4  |
| 11. Exhaust and Intake Valve Springs. . . . .  | 4  |
| 12. Intake Valves . . . . .  | 4  |
| 13. Exhaust Valve Seat Inserts. . . . .  | 4  |
| 14. Intake Valve Seat Inserts . . . . .  | 5  |
| 15. Exhaust and Intake Valve Guides . . . . .  | 5  |
| 16. Rocker Arms-With Non-Replaceable Bushings . . . . .  | 5  |
| 17. Camshaft. . . . .  | 5  |
| 18. Valve Lifters . . . . .  | 6  |
| 19. Front Gear Train Backlash . . . . .  | 6  |
| 20. Cylinder Head . . . . .  | 6  |
| 21. Lubricating Oil Pressure (First Type) or<br>Combination Oil Pressure and Oil Scavenging<br>Pump (Crankshaft Driven). . . . . | 6  |
| 22. Lubricating Oil Pressure Pump (Crankshaft Gear<br>Driven) (Current Type). . . . .  | 6  |
| 23. Water Pump. . . . .  | 6  |
| 24. Idler Gear Assembly . . . . .  | 7  |
| 25. Auxilary Pump Drive Assembly. . . . .  | 7  |
| B. TORQUE SPECIFICATIONS - BOLT, CAPSCREW, AND NUT. . . . .  | 8  |
| C. STUD GAUGE HEIGHTS . . . . .  | 11 |

### A. FITS AND TOLERANCES

#### DESCRIPTION

#### 1. Cylinder Sleeves

- a. Type. . . . .
- b. Inside diameter . . . . .
- c. Diameter of sleeve at machined area just below flange. . . . .
- d. Diameter of cylinder sleeve at packing ring location . . . . .
- e. Sleeve flange outside diameter. . . . .
- f. Cylinder block-to-sleeve clearance at sleeve lower diameter . . . . .
- g. Cylinder block-to-sleeve clearance at machined area just below flange . . . . .
- h. Cylinder block-to-sleeve clearance at sleeve flange. . . . .
- i. Clearance of piston skirt with sleeve . . . . .
- j. Fire wall height above cylinder sleeve flange . . . . .
- k. Topsurface of cylinder sleeve flange above cylinder block with sleeve installed. . . . .

|                 | SIZE OF NEW PARTS |                 |
|-----------------|-------------------|-----------------|
|                 | INCHES            | MILLIMETERS     |
| Replaceable Wet | 4.2495 - 4.2510   | 107.93 - 107.97 |
| 4.811 - 4.813   | 122.19 - 122.25   |                 |
| 4.749 - 4.751   | 120.62 - 120.67   |                 |
| 4.998 - 5.002   | 126.94 - 127.05   |                 |
| .001 - .005     | 0.02 - 0.12       |                 |
| .0005 - .0045   | 0.01 - 0.11       |                 |
| .004 - .013     | 0.10 - 0.33       |                 |
| .0025 - .0050   | 0.06 - 0.12       |                 |
| .0445 - .0475   | 1.13 - 1.20       |                 |
| .002 - .005     | 0.05 - .012       |                 |

DESCRIPTION

| SIZE OF NEW PARTS  |                      |                      |
|--|----------------------|----------------------|
|  | INCHES               | MILLIMETERS          |
| 1. Flange height adjusting shims available. . .  | .005, .010,          | 0.12 / 0.25 /        |
|  | .015 and .020        | 0.38 / 0.50          |
| m. Allowable taper. . . . .  | .0015                | 0.03                 |
| n. Allowable out-of-round (when installed). . .  | .0015                | 0.03                 |
| 2. Cylinder Block  |                      |                      |
| a. Counterbore diameter in cylinder block for cylinder sleeve flange . . . . .   | 5.006 - 5.011        | 127.15 - 127.27      |
| b. Depth of counterbore for cylinder sleeve flange . . . . .   | .3150 - .3165        | 8.00 - 8.03          |
| c. Bore in cylinder block for cylinder sleeve - Top. . . . .   | 4.8135 - 4.8155      | 122.26 - 122.31      |
| d. Bore in cylinder block for cylinder sleeve - Bottom . . . . .   | 4.752 - 4.754        | 120.70 - 120.75      |
| e. Bore in cylinder block for camshaft bearings  | 2.259 - 2.260        | 57.37 - 57.40        |
| f. Bearing bore in cylinder block for main bearings (without bearing shell, with cap in place, and capscrews tightened to specified torque). . . . . | 2.5607 - 2.5614      | 90.44 - 90.45        |
| 3. Pistons   |                      |                      |
| NOTE: Combustion chamber is in piston  |                      |                      |
| a. Combustion chamber ID. . . . .  | 2.995 - 3.005        | 76.07 - 76.33        |
| b. Combustion chamber depth . . . . .  | .569 - .579          | 14.45 - 14.71        |
| c. Material . . . . .  | Aluminum alloy       | Aluminum alloy       |
| d. Length . . . . .  | 5.8165 - 5.8365      | 147.74 - 148.25      |
| e. Diameter between top and second ring groove.  | 4.202 - 4.206        | 106.73 - 106.83      |
| f. Diameter at bottom of skirt measured at right angle to piston pin. . . . .  | 4.246 - 4.247        | 107.84 - 107.87      |
| g. Bore for piston pin (2 type bores)  |                      |                      |
| Straight bore. . . . .   | 1.5014 - 1.5017      | 38.13 - 38.14        |
| Oval bore  |                      |                      |
| Horizontal dimension (major) . . . . .   | 1.5045 - 1.5065      | 38.21 - 38.26        |
| Vertical dimension (minor) . . . . .   | 1.5014 - 1.5017      | 38.11 - 38.12        |
| i. Clearance of piston skirt with sleeve. . . . .  | .0025 - .0050        | 0.06 - 0.12          |
| 4. Piston Pins   |                      |                      |
| a. Type . . . . .  | Full floating        | Full floating        |
| b. Piston pin length. . . . .  | 3.606 - 3.616        | 91.59 - 91.84        |
| c. Diameter of pin. . . . .  | 1.5011 - 1.5013      | 38.12 - 38.13        |
| d. Fit of pin in piston at room temperature . .  | .0001 - .0006 loose  | 0.00 - 0.01 loose    |
| e. Inside diameter of connecting rod bushing. .  | 1.5027 - 1.5032      | 38.16 - 38.18        |
| f. Piston pin to connecting rod bushing clearance. . . . .   | .0014 - .0021        | 0.03 - 0.05          |
| 5. Piston Rings  |                      |                      |
| NOTE: Only standard size ring available  |                      |                      |
| a. Number of rings on each piston . . . . .  | 4                    | 4                    |
| b. Location of rings. . . . .  | All above piston pin | All above piston pin |
| c. Gap between ends - fitted   |                      |                      |
| 1st ring (chrome compression). . . . .   | .013 min - .028 max  | 0.33 min - 0.71 max  |
| 2nd and 3rd ring (compression) . . . . .   | .009 min - .024 max  | 0.22 min - 0.60 max  |
| 4th ring (oil control) . . . . .   | .009 min - .024 max  | 0.22 min - 0.60 max  |
| d. Clearance of rings in grooves   |                      |                      |
| 1st ring (chrome compression). . . . .   | .0040 - .0065        | 0.10 - 0.15          |
| 2nd and 3rd ring (compression) . . . . .   | .002 - .004          | 0.05 - 0.10          |
| 4th ring (oil control) . . . . .   | .0015 - .0030        | 0.04 - 0.07          |
| 6. Crankshaft  |                      |                      |
| a. Journal diameter for connecting rods . . . .  | 2.7470 - 2.7485      | 69.77 - 69.81        |
| b. Journal diameter for main bearings . . . . .  | 3.2465 - 3.248       | 82.44 - 82.49        |
| c. Width between connecting rod journal cheeks.  | 1.562 - 1.565        | 39.67 - 39.75        |

DESCRIPTION

| SIZE OF NEW PARTS  |                       |  |
|--|-----------------------|--|
|  | INCHES                | MILLIMETERS                                |
| d. Width of main bearing journals  |                       |  |
| Front . . . . .  | 2.137 - 2.177         | 54.28 - 55.30                              |
| Intermediates . . . . .  | 1.685 - 1.695         | 42.79 - 43.05                              |
| Center . . . . .   | 2.061 - 2.063         | 52.34 - 52.40                              |
| Rear . . . . .   | 2.014 - 2.024         | 51.15 - 51.41                              |
| e. Crankshaft end clearance . . . . .  | .007 - .013           | 0.17 - 0.33                                |
| f. Separate type thrust flanges - Available in standard and oversize of: . . . . .   | .005, .010, .015      | 0.12 / 0.25 / 0.38 oversize                |
| g. Crankshaft journals may be ground to undersizes of: . . . . .   | .010, .020, .040      | 0.25 / 0.50<br>1.01 undersize              |
| h. Fit of crankshaft gear on crankshaft . . . . .  | .001 - .003 tight     | 0.02 - 0.70 tight                          |
| 7. Main Bearings   |                       |  |
| a. Number used . . . . .   | 7                     | 7  |
| b. Type . . . . .  | Replaceable Precision | Replaceable Precision                      |
| c. Inside diameter of front, intermediate, center, and rear bearing (with capscrews tightened to specified torque) . . . . .               | 3.2499 - 3.2516       | 82.54 - 82.59                              |
| d. Diameter of crankshaft main bearing journals . . . . .  | 3.2465 - 3.2480       | 82.46 - 82.49                              |
| e. Bearing-to-journal clearance at front, intermediate, center, and rear bearings (with capscrews tightened to specified torque) . . . . . | .0019 - .0051         | 0.04 - 0.12                                |
| f. Overall length of main bearings   |                       |  |
| Front and intermediate . . . . .   | 1.432 - 1.442         | 36.37 - 36.62                              |
| Center . . . . .   | 1.682 - 1.692         | 42.72 - 42.97                              |
| Rear . . . . .   | 1.682 - 1.692         | 42.72 - 42.97                              |
| g. Undersize bearings available for service . . . . .  | .010, .020, .040      | 0.25 / 0.50 / 1.01                         |
| h. Separate type thrust flanges - Available in standard and oversizes of: . . . . .  | .005, .010, .015      | 0.12 / 0.25 / 0.38 oversize<br>3.93 - 3.94 |
| i. Bearing wall thickness - Standard bearings . . . . .  | .1549 - .1554         |  |
| j. Bearing bore in cylinder block (without bearing shell, with cap in place, and capscrews tightened to specified torque) . . . . .        | 3.5607 - 3.5614       | 90.44 - 90.45                              |
| 8. Connecting Rod Bearings   |                       |  |
| a. Type . . . . .  | Replaceable Precision | Replaceable Precision                      |
| b. Inside diameter of bearing (with capscrews tightened to specified torque) . . . . .   | 2.7495 - 2.7510       | 69.83 - 69.87                              |
| c. Diameter of crankshaft connecting rod journals . . . . .  | 2.7470 - 2.7485       | 69.77 - 69.81                              |
| d. Connecting rod bearing-to-journal clearance (with capscrews tightened to specified torque) . . . . .                                    | .001 - .004           | 0.02 - 0.10                                |
| e. Overall length of connecting rod bearings . . . . .   | 1.190 - 1.205         | 30.23 - 30.60                              |
| f. Undersize bearings available for service . . . . .  | .010, .020, .040      | 0.25 / 0.50 / 1.01                         |
| g. Bearing wall thickness (standard bearing) . . . . .   | .10975 - .11025       | 2.78 - 2.79                                |
| 9. Connecting Rods   |                       |  |
| a. Type - non-rifled drilled . . . . .   | Balanced Forged       | Balanced Forged                            |
| b. Bolts used per rod . . . . .  | 2                     | 2  |
| c. Connecting rod length (center-to-center) . . . . .  | 8.498 - 8.502         | 215.84 - 215.92                            |
| d. Inside diameter of connecting rod bushing (finished bore) . . . . .   | 1.5027 - 1.5032       | 38.16 - 38.18                              |
| e. Outside diameter of connecting rod bushing . . . . .  | Split Type            | Split Type                                 |

DESCRIPTION

| SIZE OF NEW PARTS  |                 |               |
|--|-----------------|---------------|
|  | INCHES          | MILLIMETERS   |
| f. Bearing bore (without bearing shell, with cap in place, and capscrews tightened to specified torque) . . . . .  | 2.9700 - 2.9705 | 75.43 - 75.45 |
| g. Connecting rod bearing-to-crankshaft journal clearance (with capscrews tightened to specified torque) . . . . . | .001 - .004     | 0.02 - 0.10   |
| h. Connecting rod width at lower end . . . . .   | 1.555 - 1.557   | 39.49 - 39.54 |
| i. Side clearance-to-crankshaft journal . . . . .  | .005 - .010     | 0.12 - 0.25   |
| j. Piston pin diameter . . . . .   | 1.5011 - 1.5013 | 38.12 - 38.13 |
| k. Piston pin bushing length in connecting rod . . . . .   | 1.490 - 1.510   | 37.84 - 38.35 |
| l. Piston pin to connecting rod bushing clearance . . . . .  | .0014 - .0021   | 0.03 - 0.05   |
| m. Bore in connecting rod for piston pin bushing . . . . .   | 1.6250 - 1.6255 | 41.27 - 41.28 |
| 10. Exhaust Valves   |                 |               |
| a. Valve lift (at valve) w/.015" lash . . . . .  | .413            | 10.49         |
| b. Valve lift (at cam) . . . . .   | .285            | 7.23          |
| c. Seat angle . . . . .  | 30°             | 30°           |
| d. Valve seat contact width . . . . .  | .093 (3/32)     | 2.37          |
| e. Valve lash (cold) . . . . .   | .018            | 0.45          |
| f. Valve lash (engine coolant at normal operating temperature) . . . . .   | .015            | 0.38          |
| g. Head diameter . . . . .   | 1.646 - 1.656   | 41.80 - 42.06 |
| h. Overall length . . . . .  | 6.017           | 153.08        |
| i. Stem diameter . . . . .   | .3705 - .3710   | 9.41 - 9.42   |
| j. Valve must be recessed (in head) . . . . .  | .0505-.0695     | 1.28 - 1.77   |
| 11. Exhaust and Intake Valve Springs   |                 |               |
| CAUTION: Do not intermix new and old type springs  |                 |               |
| a. Current Engines (Spring only)   |                 |               |
| Free length . . . . .  | 2.860"          | 72.64 mm      |
| Spring loaded at 2.230" (56.82 mm) . . . . .   | 60 lb.          | 27 kg         |
| Spring loaded at 1.780" (45.21 mm) . . . . .   | 127 lb.         | 58 kg         |
| b. Early Engines (Spring and damper)   |                 |               |
| Free length - spring and damper . . . . .  | 2.531"          | 64.29 mm      |
| Spring and damper loaded at 2.237" (56.81 mm) . . . . .  | 40-46 lb.       | 18-21 kg      |
| Spring and damper loaded at 1.780" (45.21 mm) . . . . .  | 105-115 lb.     | 47-52 kg      |
| NOTE: Replace spring if 5% above or below high limit   |                 |               |
| 12. Intake Valves  |                 |               |
| a. Valve lift (at valve) w/.015" lash . . . . .  | .462            | 11.73         |
| b. Valve lift (at cam) . . . . .   | .318            | 8.07          |
| c. Seat angle . . . . .  | 30°             | 30°           |
| d. Valve seat contact width . . . . .  | .093 (3/32)     | 2.37          |
| e. Valve lash (cold) . . . . .   | .018            | 0.45          |
| f. Valve lash (engine coolant at normal operating temperatures) . . . . .  | .015            | 0.38          |
| g. Head diameter . . . . .   | 1.834 - 1.844   | 46.58 - 46.83 |
| h. Overall length . . . . .  | 6.016           | 152.80        |
| i. Stem diameter . . . . .   | .3715 - .3720   | 9.43 - 9.44   |
| j. Valve must be recessed in head . . . . .  | .054 - .068     | 1.31 - 1.72   |
| 13. Exhaust Valve Seat Inserts   |                 |               |
| a. Seat angle . . . . .  | 30°             | 30°           |
| b. Seat contact width . . . . .  | .093 (3/32)     | 2.37          |
| c. Seat run-out . . . . .  | .002            | 0.05          |
| d. Insert press fit . . . . .  | .001 - .003     | 0.02 - 0.07   |
| e. Insert OD not installed . . . . .   | 1.667 - 1.668   | 45.34 - 45.36 |

DESCRIPTION

| SIZE OF NEW PARTS  |                    |                    |
|--|--------------------|--------------------|
|  | INCHES             | MILLIMETERS        |
| f. Bore in cylinder head for insert. . . . .   | 1.665 - 1.666      | 42.29 - 42.31      |
| g. Depth of counterbore in cylinder head for insert (from bottom deck of head) . . . . .   | .4735 - .4755      | 12.02 - 12.07      |
| h. Oversize insert . . . . .   | .005 over standard | 0.12 over standard |
| 14. Intake Valve Seat Inserts  |                    |                    |
| a. Seat angle. . . . .   | 30°                | 30°                |
| b. Seat width. . . . .   | .093 (3/32)        | 2.37               |
| c. Seat run-out. . . . .   | .002               | 0.05               |
| d. Insert press fit. . . . .   | .001 - .003        | 0.02 - 0.03        |
| e. Insert OD not installed . . . . .   | 1.8110 - 1.8120    | 45.99 - 46.02      |
| f. Bore in cylinder head for insert. . . . .   | 1.809 - 1.810      | 45.94 - 45.97      |
| g. Depth of counterbore in head for insert (from bottom deck of head). . . . .   | .4585 - .4605      | 11.64 - 11.69      |
| 15. Exhaust and Intake Valve Guides  |                    |                    |
| a. Length. . . . .   | 2.875 (2 7/8)      | 73.02              |
| b. Inside diameter after assembly . . . . .  | See Note           | See Note           |
| c. Stem-to-guide clearance after reaming   |                    |                    |
| Exhaust . . . . .  | .0025 - .0037      | 0.06 - 0.09        |
| Intake. . . . .  | .0015 - .0027      | 0.04 - 0.07        |
| d. Guide stand-out from bottom of counterbore in cylinder head   |                    |                    |
| Exhaust . . . . .  | 1.093 (1 3/32)     | 27.77              |
| Intake. . . . .  | .781 (25/32)       | 19.84              |
| NOTE: Valve guides in new production and new factory service heads do not require reaming in the field. They are factory bearing-ized to .3735-.3742 (9.487-9.488mm) inside diameter. Checked with a .37250-.37254 inch (9.461-9.462mm) diameter GO plug, 3 inch (76mm) long. A .373 (9.47mm) reamer maybe used as a straightness gauge. |                    |                    |
| 16. Rocker Arms - With Non-Replaceable Bushings  |                    |                    |
| a. ID of rocker arm bushing (finish bore). . .   | 1.001 - 1.002      | 25.42 - 25.45      |
| b. OD of rocker arm shaft . . . . .  | .999 - 1.000       | 25.37 - 25.40      |
| c. Rocker arm shaft-to-rocker arm bushing clearance . . . . .  | .001 - .003        | 0.03 - 0.08        |
| d. Rocker arm ratio. . . . .   | 1.5:1              | 1.5:1              |
| e. Plug rocker arm shaft . . . . .   | 3/4 - 16 UNF - 2A  | 3/4 - 16 UNF - 2A  |
| f. Restrictor elbow - flywheel end . . . . .   | .062               | 1.58               |
| 17. Camshaft   |                    |                    |
| a. Number of bearings used . . . . .   | 6                  | 6                  |
| b. ID of camshaft bearing (when installed) . .   | 2.133 - 2.135      | 54.17 - 54.23      |
| c. OD of camshaft journals . . . . .   | 2.130 - 2.131      | 54.10 - 54.12      |
| d. Camshaft bearing-to-journal running clearance . . . . .   | .002 - .005        | 0.05 - 0.13        |
| e. OD of camshaft bearings . . . . .   | 2.263 - 2.265      | 57.48 - 57.53      |
| f. Bore in cylinder block for bearing. . . . .   | 2.259 - 2.260      | 57.37 - 57.40      |
| g. Fit of camshaft bearings in bore of cylinder block . . . . .  | .003 - .006 tight  | 0.07 - 0.15 tight  |
| h. Overall width of camshaft bearings  |                    |                    |
| Front . . . . .  | 1-3/8              | 34.92              |
| Intermediates . . . . .  | 1                  | 25.04              |
| Rear. . . . .  | 1                  | 25.04              |
| i. Camshaft end play . . . . .   | .001-.011          | 0.03 - 0.28        |
| j. Camshaft gear width . . . . .   | 1                  | 25.04              |

DESCRIPTION

| SIZE OF NEW PARTS  |                                 |                                 |
|--|---------------------------------|---------------------------------|
| DESCRIPTION  | INCHES                          | MILLIMETERS                     |
| k. Fit of camshaft gear on camshaft. . . . .   | .0025-.0040 tight               | 0.06 - 0.10 tight               |
| l. Specified thickness of thrust collar. . . . .   | .204 - .206                     | 5.18 - 5.23                     |
| 18. Valve Lifters  |                                 |                                 |
| a. Bore in cylinder block for valve lifter . . .   | .7495 - .7505                   | 19.03 - 19.06                   |
| b. OD of valve lifter stem . . . . .   | .7480 - .7485                   | 18.99 - 19.01                   |
| c. Fit of valve lifter in bore of cylinder<br>block . . . . .  | .001 - .0025                    | 0.02 - 0.06                     |
| 19. Front Gear Train Backlash  |                                 |                                 |
| a. Crankshaft gear to camshaft gear. . . . .   | .0037-.0068                     | 0.09 - 0.17                     |
| b. Crankshaft gear to idler gear . . . . .   | .0037-.0064                     | 0.09 - 0.16                     |
| c. Fuel pump drive gear to fuel pump driven<br>gear . . . . .  | .0044-.0070                     | 0.11 - 0.18                     |
| d. Camshaft gear to hydraulic pump gear. . . . .   | .0055-.0086                     | 0.14 - 0.22                     |
| 20. Cylinder Head  |                                 |                                 |
| a. Valve sequence (front to rear in each head)   | Exhaust - Intake                | Exhaust - Intake                |
| 21. Lubricating Oil Pressure Pump (First Type)<br>or Combination Oil Pressure and Oil<br>Scavenging Pump (Crankshaft Driven) |                                 |                                 |
| a. Radial clearance - gears to pump body . . .   | .0020 - .004                    | 0.05 - 0.10                     |
| b. End clearance   |                                 |                                 |
| Gear - oil pressure . . . . .  | .0025 - .0065                   | 0.06 - 0.16                     |
| Gear - oil scavenging . . . . .  | .010 - .013                     | 0.25 - 0.33                     |
| c. Bore for bushing. . . . .   | .9995 - 1.0005                  | 25.39 - 25.41                   |
| d. Bushing O.D. - idler gear . . . . .   | 1.003 - 1.005                   | 25.48 - 25.53                   |
| e. Bore in body, cover, and idler gear bushing   | .874 - .875                     | 22.19 - 22.22                   |
| f. Shaft O.D. . . . .  | .8715 - .8720                   | 22.13 - 22.14                   |
| g. Bore in body for idler shaft. . . . .   | .8695 - .8705                   | 22.08 - 22.11                   |
| Fit - Idler shaft to body. . . . .   | .0010 - .0025 tight             | 0.02 - 0.06 tight               |
| h. Clearance - Shafts to body, cover, and<br>idler gear bushing. . . . .   | .0020 - .0035                   | 0.05 - 0.08                     |
| i. Bore in pump drive gear for shaft . . . . .   | .8695 - .8705                   | 22.08 - 22.11                   |
| Fit - Shaft to drive gear . . . . .  | .0010 - .0025 tight             | 0.02 - 0.06 tight               |
| 22. Lubricating Oil Pressure Pump (Crankshaft Gear<br>Drive) (Current Type)  |                                 |                                 |
| a. Radial clearance - gear to pump body. . . . .   | .004 - .009                     | 0.10 - 0.23                     |
| b. Gear end clearance. . . . .   | .004 - .009                     | 0.10 - 0.23                     |
| c. Bore for bushing. . . . .   | .9995 - 1.0005                  | 25.39 - 25.41                   |
| d. Fit - bushing to body and plate . . . . .   | .002 - .004 tight               | 0.05 - 0.10 tight               |
| e. Bushing installed ID. . . . .   | .873 - .875                     | 22.17 - 22.23                   |
| f. Clearance shaft to bushing. . . . .   | .001 - .035                     | 0.03 - 0.89                     |
| g. Shaft OD. . . . .   | .8715 - .8720                   | 22.14 - 22.15                   |
| h. Position of oil gear from end of shaft. . .   | .550 - .560                     | 13.97 - 14.22                   |
| i. Drive gear and oil gears ID . . . . .   | .8695 - .8705                   | 22.09 - 22.11                   |
| j. Fit - drive gear and oil gears to shafts. .   | .001 - .0035 tight              | 0.03 - 0.09 tight               |
| k. Clearance side of drive gear to body. . . . .   | .003                            | 0.08                            |
| 23. Water Pump   |                                 |                                 |
| a. Clearance - impeller to housing . . . . .   | Set w/.010-.040<br>feeler gauge | Set w/0.25-1.01<br>feeler gauge |
| b. Bearing   |                                 |                                 |
| Bearing O.D. . . . .   | 1.4995 - 1.5000                 | 38.08 - 38.10                   |
| Bore in water pump body (for bearing) . .  | 1.498 - 1.499                   | 38.04 - 38.07                   |
| Fit - Bearing OD to body. . . . .  | .0005 - .002 tight              | 0.01 - 0.05 tight               |

| DESCRIPTION  | SIZE OF NEW PARTS   |                   |
|--|---------------------|-------------------|
|  | INCHES              | MILLIMETERS       |
| c. Impeller  |                     |                   |
| Bore in impeller for shaft . . . . .                         | .6237 - .6247       | 15.84 - 15.87     |
| Shaft diameter . . . . .                                     | .6262 - .6267       | 15.90 - 15.91     |
| Fit - Shaft diameter to impeller bore . . . . .              | .0015 - .0030 tight | 0.04 - 0.08 tight |
| d. Hub - for water pump pulley                               |                     |                   |
| Bore in hub for shaft . . . . .                              | .7435 - .7445       | 18.88 - 18.90     |
| Shaft diameter . . . . .                                     | .7460 - .7465       | 18.94 - 18.95     |
| Fit - Shaft diameter to hub bore . . . . .                   | .0015 - .0030 tight | 0.03 - 0.07 tight |
| 24. Idler Gear Assembly                                      |                     |                   |
| a. Idler gear bearing  |                     |                   |
| Bearing bore (ID for idler shaft) . . . . .                  | 1.000 - 1.0008      | 25.40 - 25.42     |
| Shaft diameter . . . . .                                     | .9990 - 1.0000      | 25.37 - 25.40     |
| Fit - Shaft to bearing . . . . .                             | .0000 - .0018 loose | 0.00 - 0.04 loose |
| Bearing OD . . . . .   | 1.980 - 1.981       | 50.29 - 50.31     |
| Bore in idler gear . . . . .                                 | 1.9785 - 1.9795     | 50.25 - 50.27     |
| Fit - Bearing OD to idler gears . . . . .                    | .0005 - .0025 tight | 0.01 - 0.06 tight |
| Bore in cylinder block for idler gear shaft . . . . .        | .998 - .999         | 25.34 - 25.37     |
| Idler shaft OD . . . . .                                     | .9990 - 1.000       | 25.37 - 25.40     |
| Fit - Idler shaft to bore in cylinder block . . . . .        | .0000 - .002 tight  | 0.00 - 0.05 tight |
| 25. Auxiliary Pump Drive Assembly                            |                     |                   |
| a. Hydraulic pump drive bearing                              |                     |                   |
| Bearing bore (I.D. for hydraulic pump drive shaft) . . . . . | 1.500 - 1.5005      | 38.10 - 38.11     |
| Shaft diameter . . . . .                                     | 1.4995 - 1.5005     | 38.08 - 38.11     |
| Fit - Shaft to bearing . . . . .                             | .0005 - .0010 loose | 0.01 - 0.02 loose |
| Bearing O.D. . . . .   | 2.5625 - 2.5635     | 55.08 - 55.11     |
| Bore in hydraulic pump drive housing for bearing . . . . .   | 2.5615 - 2.5625     | 55.06 - 55.08     |
| Fit - Bearing O.D. to hydraulic pump drive housing . . . . . | .0000 - .002 tight  | 0.00 - 0.05 tight |

B. TORQUE SPECIFICATIONS - BOLT, CAPSCREW AND NUT

1. Specific Torque Values

The torque values tabulated below have been calculated for specific applications. SAE standard torque values must not be used where those listed in this table apply.

IMPORTANT: All torque values in the following tables are for threads lubricated with engine oil.

NOTE: Torque values are in pound feet except where pound inches are specified.

| TYPE     | DESCRIPTION                           | SIZE AND THREAD                       | GRADE   | ENGLISH TORQUE LB-FT | METRIC TORQUE Nm |
|----------|---------------------------------------|---------------------------------------|---------|----------------------|------------------|
| Capscrew | Bearing Cap, Main                     | 5/8-11 x 4.250                        | 8       | 190                  | 258              |
| Capscrew | Connecting Rod Cap                    | (Hex Socket Hd.)<br>7/16-20 x 2.125   | 100     | 85                   | 115              |
| Capscrew | Connecting Rod Cap                    | (12 Pt. Socket Hd.)<br>7/16-20 X 2.25 | 100     | 67.5                 | 91.5             |
| Capscrew | Cyl Head Mtg (Short)                  | 9/16-12 x 5.062                       | 8       | 165                  | 224              |
| Capscrew | Cyl. Head Mtg. (Long)                 | 9/16-12 x 8.125                       | 8       | 165                  | 224              |
| Capscrew | Cyl. Head Cover                       | 1/4-20 x 0.625                        | 2       | 4                    | 5                |
| Nut      | Fuel Injection Pump Shaft Retaining   | Special                               | -       | 40                   | 54               |
| Nut      | Nozzle Retaining                      | Special                               | -       | 50                   | 68               |
| Locknut  | Nozzle Adjusting Screw                | 7/8-20                                | -       | 50                   | 68               |
| Nut      | Nozzle Fuel Line                      | Ermetto Nut                           | -       | 25                   | 34               |
| Capscrew | Nozzle Holder Mounting                | 5/16-18 x 1.625                       | 2       | 13                   | 18               |
| Plug     | Rocker Arm Shaft-Plug                 | 3/4-16                                | 2       | 40                   | 54               |
| Nut      | Turbocharger Mtg.                     | 3/8-16                                | Stn.Stl | 20                   | 27               |
| Capscrew | Flywheel to Crankshaft                | 1/2-20 x various                      | -       | 135                  | 183              |
| Capscrew | Crankshaft Pulley                     | 1-14 x 2.000                          | 5       | 220                  | 298              |
| Capscrew | Intake Manifold Mounting              | 3/8-16 x 1.250                        | 5       | 20                   | 27               |
| Nut      | Auxiliary Pump Drive Brg. Retaining   | 1-8/3-12                              | -       | 250                  | 339              |
| Capscrew | Oil Filter Relief Valve Retaining     | 3/4-16 x 1.375                        | 2       | 125                  | 170              |
| Nut      | Turbo Compression Hsg. Clamp          | 10-32                                 | -       | *60                  | 6.78             |
| Capscrew | Turbo. Turbine Hsg. to Center Hsg.    | 5/16-18 x .500                        | 2       | *120                 | 13.56            |
| Capscrew | Turbo. Compressor Hsg. to Center Hsg. | 5/16-18 x .500                        | 2       | *120                 | 13.56            |
| Nut      | Turbo. Impeller                       | 5/16-24                               | -       | *20                  | 2.26             |
| Capscrew | Turbo. Backplate to Center Hsg.       | 1/4-20 x .625                         | -       | *85                  | 9.60             |

\*inch-lbs



2. Standard Torque Values

8, six marks, 60° apart. (See figures in table below.

The heads of capscrews used in Allis-Chalmers engines bear grade marks conforming to standards specified by the Society of Automotive Engineers (SAE). The three grades of capscrews used are identified as follows: Grade 2, no marks; Grade 5, three marks, 120° apart; Grade

CAUTION: The standard torque values tabulated above are for use when specific torque data is not available. Do not use these values in place of those specified elsewhere in this manual.

a. Grade 2 Capscrews

| Grade 2 Capscrew Standard Torque Values |               |           |                           |               |           |
|---|---------------|-----------|---------------------------|---------------|-----------|
| National Coarse (NC) Thread             |               |           | National Fine (NF) Thread |               |           |
| Size Inches(")                          | English lb-ft | Metric Nm | Size Inches(")            | English lb-ft | Metric Nm |
| 1/4-20                                  | 5-7           | 7-9       | 1/4-28                    | 6-8           | 8-11      |
| 5/16-18                                 | 11-13         | 15-18     | 5/16-24                   | 13-15         | 18-20     |
| 3/8-16                                  | 18-21         | 24-28     | 3/8-24                    | 19-22         | 26-30     |
| 7/16-14                                 | 30-33         | 41-45     | 7/16-20                   | 32-35         | 43-47     |
| 1/2-13                                  | 45-50         | 61-68     | 1/2-20                    | 45-50         | 61-68     |
| 9/16-12                                 | 60-65         | 81-88     | 9/16-18                   | 60-65         | 81-88     |
| 5/8-11                                  | 75-85         | 102-115   | 5/8-18                    | 75-85         | 102-115   |
| 3/4-10                                  | 125-135       | 170-183   | 3/4-16                    | 125-135       | 170-183   |
| 7/8-9                                   | 105-115       | 143-156   | 7/8-14                    | 105-115       | 143-156   |
| 1-8                                     | 155-165       | 211-224   | 1-14                      | 140-150       | 190-204   |

b. Grade 5 Capscrews

| Grade 5 Capscrew Standard Torque Values |               |           |                           |               |           |
|---|---------------|-----------|---------------------------|---------------|-----------|
| National Coarse (NC) Thread             |               |           | National Fine (NF) Thread |               |           |
| Size Inches(")                          | English lb-ft | Metric Nm | Size Inches(")            | English lb-ft | Metric Nm |
| 1/4-20                                  | 9-11          | 12-15     | 1/4-28                    | 11-13         | 15-18     |
| 5/16-18                                 | 18-20         | 24-27     | 5/16-24                   | 21-23         | 28-31     |
| 3/8-16                                  | 28-33         | 38-45     | 3/8-24                    | 30-35         | 41-47     |
| 7/16-14                                 | 44-49         | 60-66     | 7/16-20                   | 50-55         | 68-75     |
| 1/2-13                                  | 68-73         | 92-99     | 1/2-20                    | 68-73         | 92-99     |
| 9/16-12                                 | 95-105        | 129-143   | 9/16-18                   | 95-105        | 129-143   |
| 5/8-11                                  | 125-135       | 170-183   | 5/8-18                    | 125-135       | 170-183   |
| 3/4-10                                  | 210-230       | 285-312   | 3/4-16                    | 210-230       | 285-312   |
| 7/8-9                                   | 290-310       | 393-421   | 7/8-14                    | 290-310       | 393-421   |
| 1-8                                     | 420-450       | 569-610   | 1-14                      | 380-410       | 515-556   |

c. Grade 8 Capscrews

| Grade 8 Capscrew Standard Torque Values |               |           |                           |               |           |
|---|---------------|-----------|---------------------------|---------------|-----------|
| National Coarse (NC) Thread             |               |           | National Fine (NF) Thread |               |           |
| Size Inches(")                          | English lb-ft | Metric Nm | Size Inches(")            | English lb-ft | Metric Nm |
| 1/4-20                                  | 12-14         | 16-19     | 1/4-28                    | 14-16         | 19-22     |
| 5/16-18                                 | 25-27         | 34-37     | 5/16-24                   | 28-30         | 38-41     |
| 3/8-16                                  | 41-46         | 56-62     | 3/8-24                    | 43-48         | 58-65     |
| 7/16-14                                 | 69-74         | 94-100    | 7/16-20                   | 72-77         | 98-104    |
| 1/2-13                                  | 95-105        | 129-143   | 1/2-20                    | 95-105        | 129-143   |
| 9/16-12                                 | 130-140       | 177-190   | 9/16-18                   | 130-140       | 177-190   |
| 5/8-11                                  | 170-190       | 231-258   | 5/8-18                    | 170-190       | 231-258   |
| 3/4-10                                  | 290-310       | 393-421   | 3/4-16                    | 290-310       | 393-421   |
| 7/8-9                                   | 450-500       | 610-678   | 7/8-14                    | 450-500       | 610-678   |
| 1-8                                     | 670-700       | 908-949   | 1-14                      | 600-630       | 813-854   |

C. STUD GAUGE HEIGHTS

| Stud Description                           | Stud Size |          |         |        | Gauge Height |      | Driving Torque* |       |         |
|--|-----------|----------|---------|--------|--------------|------|-----------------|-------|---------|
|  | Dia.      | Thread   |         | Length |              | in.  | mm              | lb-ft | Nm      |
|  |           | Stud End | Nut End | in.    | mm           |      |                 |       |         |
| Fuel Injection Pump Adaptor to Front Plate | 3/8       | 24       | 24      | .96    | 24.4         | .65  | 16.1            | 10-35 | 136-475 |
| Hole Cover to Front Plate                  | 3/8       | 24       | 24      | 1.38   | 35.1         | 1.06 | 26.9            | 10-35 | 136-475 |

\*Torque values in this table are calculated for threads lubricated with engine oil.



## TOPIC 11. COOLING SYSTEM

### A. GENERAL

Depending upon the optional cooling system components selected for a particular engine application, proper temperature of engine coolant is maintained by a radiator and fan combination, or by a heat exchanger and expansion tank. The most commonly used system is the radiator and fan combination (Fig 1). If the heat exchanger and expansion tank cooling system (Fig 2) is utilized, the owner must supply ample raw water under pressure to the heat exchanger.

In addition to the major components mentioned, the engine cooling system also includes a water pump, water inlet piping, water outlet piping, water cooled exhaust manifold, thermostats, engine oil cooler, coolant filter, coolant passages in cylinder block and heads, coolant

temperature gauge, and immersion heater.

The function of the cooling system is to prevent temperatures in the combustion chamber from damaging the engine and at the same time keep operating temperatures within safe limits.

Proper maintenance of the cooling system is important. Engine temperature must be brought up to and maintained within satisfactory range for efficient operation, and engine must be kept from overheating in order to prevent damage to valves, pistons, sleeves, and bearings.

### B. RADIATOR AND FAN TYPE COOLING SYSTEM

Coolant is drawn from the bottom of the radiator into the inlet side of the coolant pump. Coolant from the outlet side of the pump enters

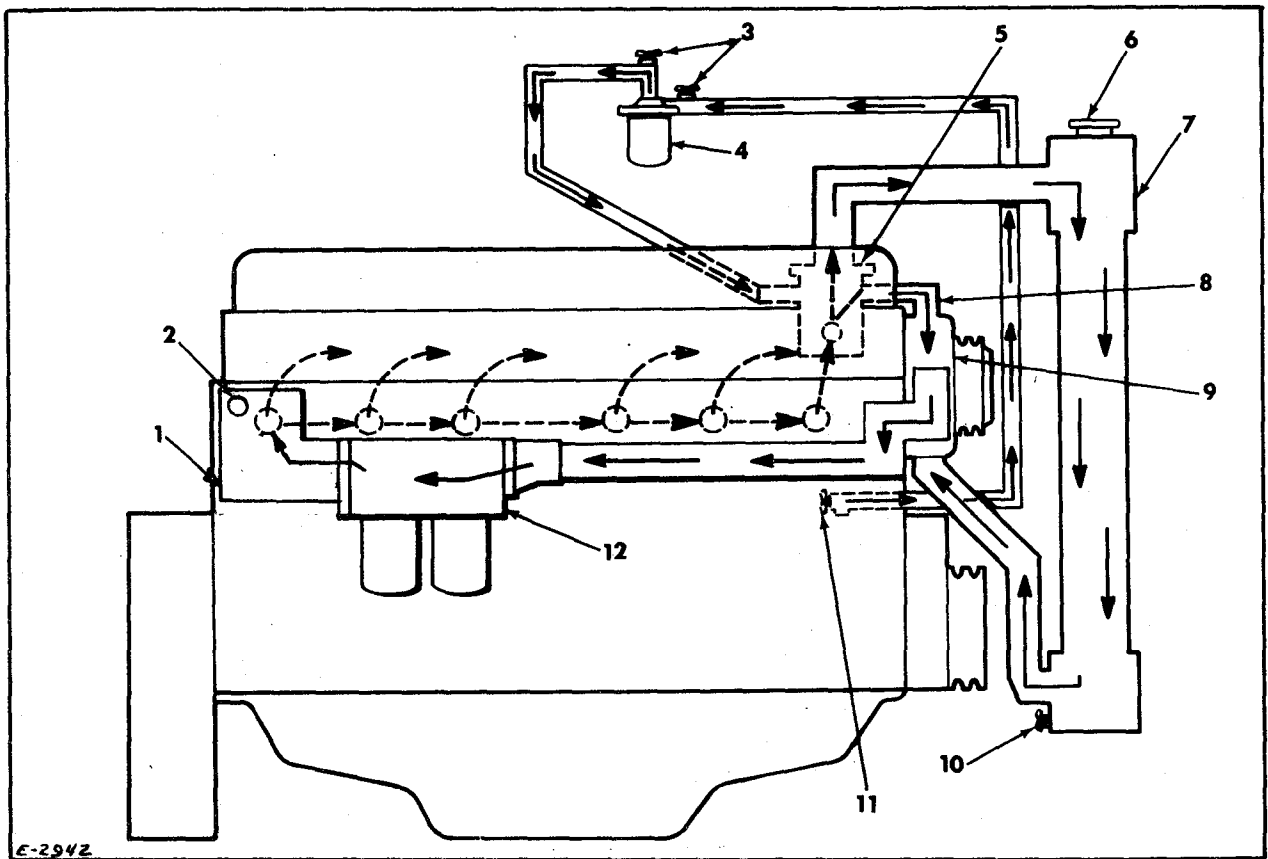

E-2942

1. Water inlet elbow
2. Immersion heater
3. Shutoff valves
4. Coolant filter
5. Thermostats and housing
6. Radiator cap - 7 psi (48 kNm<sup>2</sup>)
7. Radiator

8. Bypass hose
9. Coolant pump
10. Radiator drain valve
11. Cylinder block drain cock
12. Oil cooler

Figure 1. Radiator and Fan Type Cooling System Schematic Diagram

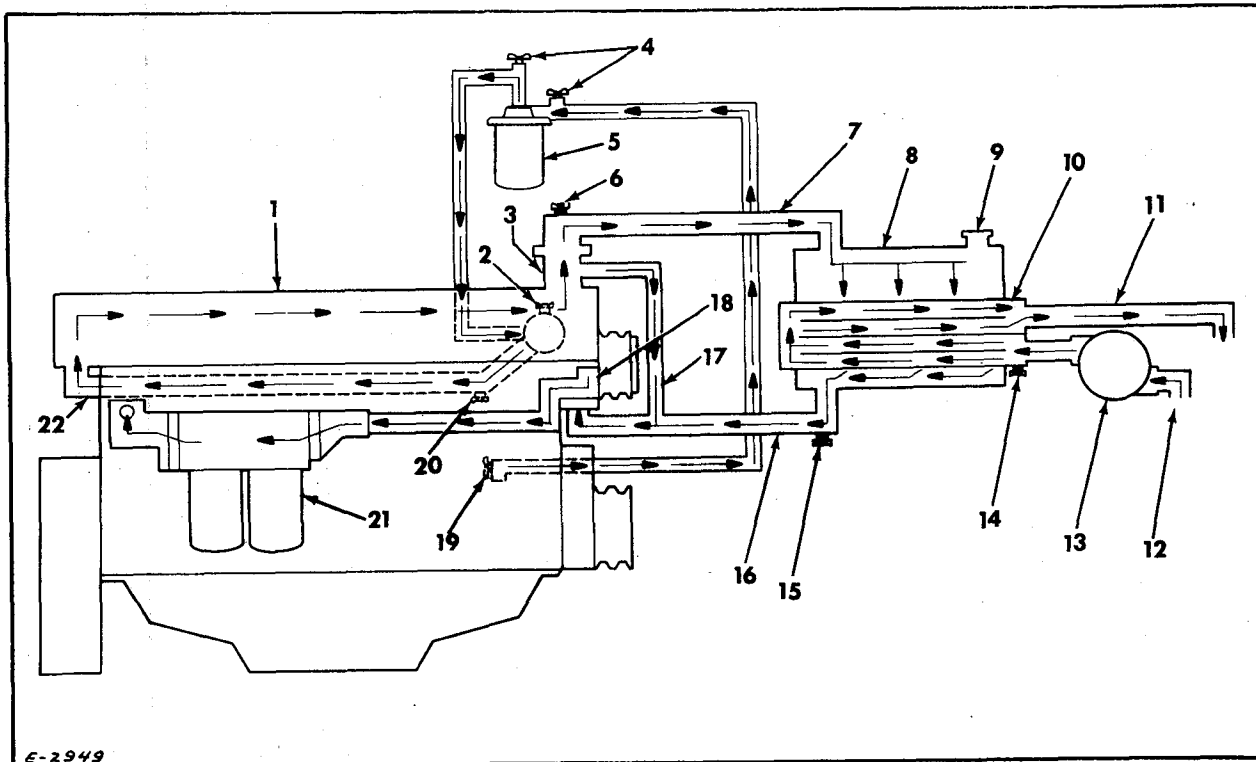

E-2949

- |   |   |
|---|---|
| 1. Water cooled exhaust manifold                | 12. Customer supplied source of raw water       |
| 2. Vent cock                                    | 13. Customer supplied raw water pump            |
| 3. Thermostats and housing                      | 14. Drain cock                                  |
| 4. Shutoff valves                               | 15. Drain cock                                  |
| 5. Coolant filter                               | 16. Tube - heat exchange to engine coolant pump |
| 6. Vent cock                                    | 17. Bypass hose                                 |
| 7. Water outlet pipe                            | 18. Engine coolant pump                         |
| 8. Heat exchanger expansion tank                | 19. Drain cock - cylinder block                 |
| 9. Pressure cap - 7 psi (48 kN/m <sup>2</sup> ) | 20. Drain cock                                  |
| 10. Tube bundle - heat exchanger                | 21. Oil cooler                                  |
| 11. Raw water discharge                         | 22. Tube - cylinder head to exhaust manifold    |

Figure 2. Heat Exchanger and Expansion Tank Cooling System Schematic Diagram

external piping and passes through the engine oil cooler. The coolant enters the engine block through an elbow connected to the water inlet manifold which is cast in the engine block. From the manifold, coolant circulates around the cylinder sleeves and into the cylinder head. The coolant then passes into the thermostat housing, the upper radiator hose and the top tank of the radiator.

As the coolant passes from top to bottom through the radiator, heat is dissipated to the air that is being forced through the radiator by the cooling fan.

The cooling system is pressurized by a 7 psi (48 kN/m<sup>2</sup>) pressure cap. By pressurizing the system, the normal boiling point of 212°F (373 K) of clean water at sea level is raised approximately 3°F per psi (0.24 K per kN/m<sup>2</sup>). Consequently, coolant in the system at sea level will not boil until a temperature of 212°F,

(373 K), plus 21°F (12 K), or a total of 233°F (385 K) is reached. Temperatures above this figure will cause loss of coolant and result in engine overheating. Altitude effects the point at which coolant will boil, that is, the higher the altitude, the sooner (lower temperature) the coolant will boil. To estimate coolant boiling point at various altitudes above sea level, deduct 1-1/2°F per 1000 ft. (0.83 K per 304.8 m) altitude, from 233°F (385 K), the boiling point established with a 7 psi (48 kN/m<sup>2</sup>) pressure cap at sea level.

**IMPORTANT:** The engine thermostats begin to open at 180°F (355 K) and are fully open at 200°F (366 K). Operating the engine in this temperature range is not harmful. However, some temperature gauges are not always exactly accurate and may indicate a higher than actual temperature. This can lead the operator to

**IMPORTANT (continued):** believe the engine is overheating when actually it is operating normally.

Overheating is always associated with loss of coolant. In the event of any doubt, the coolant level in the radiator or expansion tank should be checked.

A double-acting valve in the pressure cap relieves air pressure caused by expansion of heated coolant, and allows atmospheric pressure to enter when cooling contraction occurs. Because this is a pressure-type cooling system, it is necessary to keep the cap turned on tightly at all times to prevent loss of pressure.

**WARNING: DO NOT REMOVE PRESSURE CAP WHILE COOLANT TEMPERATURE IS 212°F (373 K) OR ABOVE BECAUSE COOLANT WILL BOIL VIOLENTLY AND MAY SPLASH ON PERSON REMOVING THE CAP.**

#### C. HEAT EXCHANGER AND EXPANSION TANK TYPE COOLING SYSTEM.

The heat exchanger and expansion tank perform the same functions that the radiator and fan do in the radiator and fan type cooling system. The expansion tank is the reservoir for the engine coolant. As the coolant is heated and expands, it enters the expansion tank and is retained there until it recirculates. The top of the tank is located slightly above the highest point in the engine cooling system, coolant in the engine and heat exchanger. The expansion tank filler cap is the pressurized type (7 psi) (48 kN/m<sup>2</sup>).

The coolant is drawn from the bottom of the expansion tank and conveyed to the inlet side of the water pump. The coolant then passes through the water pump-to-engine oil cooler tube and then through the engine oil cooler. From the oil cooler the coolant enters the engine block through an elbow connected to the water inlet manifold which is cast in the cylinder block. From the manifold, coolant circulates around the cylinder sleeves and through the cylinder head, to the outlet elbow. From the outlet elbow, it flows through external piping to the rear of the water cooled exhaust manifold passing through the water exhaust manifold to the thermostat housing. If the thermostats are closed, coolant is bypassed to the water pump and repeats the same circulation path. If the thermostats are open, coolant then returns to the heat exchanger expansion tank.

The customer-supplied raw water pump circulates the raw water through the inside of the heat exchanger tubes. The engine coolant is circulated around the outside of the tubes by

the engine coolant pump. Heat in the engine coolant is dissipated to the raw water.

#### D. GENERAL MAINTENANCE

When the optional equipment coolant filter/conditioner is specified, engine life is extended by the filter/conditioner maintaining a rust, scale and corrosion free cooling system. Refer to Paragraph K describing the function and operation of the coolant filter/conditioner.

Engines operating in areas where the ambient temperature is always above freezing must be kept full of an all-seasons coolant system fluid used as recommended by the manufacture or clean soft water. The water must be as free as possible of scale forming minerals and have an inhibitor added to it. The inhibitor must prevent the formation of rust and contain a lubricant to lubricate the coolant seals of the coolant (water) pump. Follow the instructions printed on the inhibitor container.

**CAUTION:** If possible, do not use household type softened water because its pH factor is low (acidity). Distilled or clean rain water is preferable.

In winter use a permanent type antifreeze solution in the system to protect against damage from freezing. After any addition of water or antifreeze compound, test the solution after it has become thoroughly mixed to assure it will withstand prevailing or anticipated temperatures.

**CAUTION:** Do not use antifreeze solutions that are harmful to aluminum.

Refer to instructions on protection charts furnished by the antifreeze manufacturer for information on quantity required for lowest anticipated temperature. Keep radiator air passages free of leaves, trash, and other material that may restrict flow of air through the radiator.

**CAUTION:** Keep cylinder head capscrews, water pump mounting capscrews, hose clamps, and fitting connections tight. Correct all leaks as soon as they become evident. Inspect hoses carefully and replace them if they have deteriorated.

The engine operates most efficiently when coolant temperature is 180°F (355 K) minimum. Operation with low coolant temperature will result in incomplete fuel combustion, higher fuel consumption with less power, and formation

of harmful deposits in the engine. A properly functioning thermostat is required to maintain normal coolant temperature. If the coolant temperature is consistently below 180°F (355 K) the thermostat should be removed, checked for proper operation, and replaced if necessary.

#### E. DRAINING COOLING SYSTEM

1. Engines installed in portable type equipment must be in a level position to assure complete draining.

**CAUTION:** To prevent damage to the optional equipment immersion heater element (Fig 3), disconnect the power source to the heater before draining cooling system.

2. If engine is cooled with radiator, remove radiator cap (Fig 1 Item 6) open radiator drain cock (10), cylinder block drain cock (11).
3. Leave coolant filter shutoff valves (Fig 1 Item 3 and Fig 2 Item 4) in open position. Remove spin-on type filter (Fig 1 Item 4 and Fig 2 Item 5) and install new filters after draining the cooling system.
4. If engine is cooled with heat exchanger and expansion tank, shut off source of raw water and open heat exchanger tube bundle (Fig 2 Item 10) drain cock (14). Remove expansion tank cap (9) and open vent cocks (2 and 6). Open engine coolant drain cocks (15) located in coolant tube (16) to drain expansion tank (8), cylinder block drain cock (19), and drain cock (20) to drain water cooled exhaust manifold. Process coolant filter as indicated in Step 3 above.
5. If applicable, open drain cocks of any optional equipment applied to the engine will require the coolant to be drained from it.

**CAUTION:** When draining cooling system in freezing weather, make certain coolant flows freely from drains and the system drains completely.

#### F. FILLING COOLING SYSTEM

1. Close all drains that were opened to drain system. (Refer to preceding Paragraph E.)
2. Fill system with clean, soft water or antifreeze solution until level is

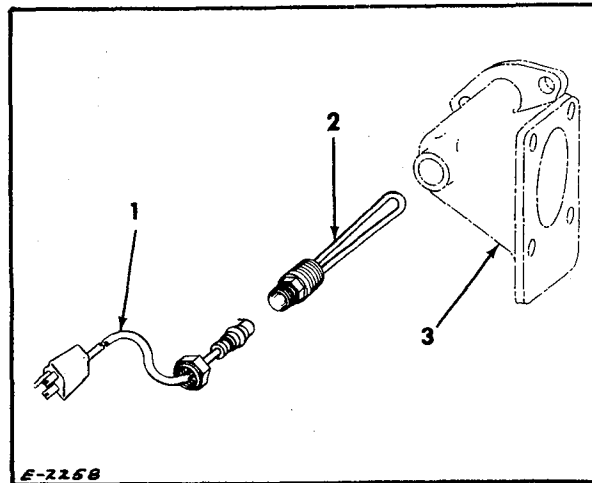

1. Heater cord
2. Element
3. Water outlet elbow-at rear of oil cooler

Figure 3. Immersion Heater

approximately 1.50" (38.10 mm) below bottom of filler neck. Install filler cap.

If heat exchanger type cooling, close vent cocks when coolant free of air bubbles appears.

3. Operate engine for a period of time at normal operating temperature to vent all air from system.
4. Check level of coolant in radiator and if necessary, add coolant to attain proper level.

#### G. CLEANING OF COOLING SYSTEM

1. Clean cooling system at beginning of cold weather before antifreeze is added, and again after antifreeze is drained for warm weather operation. Also, drain, flush, and refill system whenever inspection reveals an accumulation of rust and scale.
2. If engine is provided with a coolant filter that has been properly maintained, cleaning of system should not be necessary. However, the coolant filter's effectiveness is only as good as the maintenance it receives. If inspection reveals coolant to be a brown and rusty color, drain, flush, and refill cooling system; replace coolant filter element.

3. Many good solvents are on the market for cleaning of cooling systems; use according to manufacturer's instructions.



**CAUTION:** Do not mix antifreeze compounds or inhibitors with any cleaning, neutralizing, or flushing compounds.

4. If radiator tubes are clogged, reverse flush radiator as follows:
  - a. Disconnect upper and lower radiator hoses.
  - b. Connect a pressure water hose to lower connection with a suitable adaptor.
  - c. Plug upper connection and remove radiator cap.
  - d. Force water through radiator. Foreign material will flow out through top of radiator with the water.

**CAUTION:** Do not use more than 5 or 6 psi (35 or 41 kN/m<sup>2</sup>) pressure when flushing. Excessive pressure may rupture radiator.

5. Keep radiator air passages free of debris and other obstructions. Clean exterior with an air blast carrying a grease solvent. If engine is equipped with sucker type fan, direct cleaning spray at rear (fan side) of radiator. For engines having a blower type fan, direct spray at front of radiator.

**WARNING:** Keep engine covered during cleaning operation. Provide adequate ventilation to avoid toxic effects of the cleaning spray. Do not clean with gasoline, fuel oil, or kerosene.

6. Before putting cleaning solvent in radiator, close coolant filter inlet and outlet shutoff valves (Fig 6).
7. After the cooling system has been cleaned and flushed, open coolant filter shutoff valves. Install new coolant filter. Fill cooling system to proper level. Inspect entire system for coolant leaks. Correct any leaks found to avoid foaming, corrosion, and loss of coolant.

#### H. ENGINE OIL COOLER

##### 1. General

The engine oil cooler assembly (Fig 4) consists of an oil cooler with corrosion resistant tubes, water inlet and outlet headers plus an oil filter header. The coolant pump circulates coolant through the cooling tubes and the engine oil pressure pump circulates oil through the

tank, around the outside of the tubes of the cooling core, thereby controlling oil temperature.

The oil cooler consists of small tubes which dissipate heat from the oil to the engine coolant. If the proper lubricating oil maintenance procedure is followed, the oil cooler will function efficiently. However, if the oil in the engine is not changed at the recommended intervals, impurities will be deposited in the cooler and will restrict the flow of oil around the tubes of the cooling core. Restriction of the flow of oil to the cooler is usually indicated by a drop in oil pressure, due to oil overheating. If this occurs, the oil cooler must be cleaned or be replaced.

**CAUTION:** It is absolutely necessary that the oil cooler be kept clean to provide for proper oil cooling.

The cooler is the single pass type. The term "single pass" refers to coolant flow, not to engine oil flow. The coolant flows in one end of the cooler, through the tubes and is discharged through the outlet. The coolant then flows into the engine cylinder block.

Two o-rings at each end of the cooler seal the coolant and lube oil in the housing. The o-rings are made of two different materials and their use and location are dependent upon the substance they have to seal. The blue color coded o-rings are positioned to seal out the water and the yellow color o-ring seal in the oil. On the side and near the rear of the housing is a small bleed hole (Fig 4 Item 18). It is drilled through the housing and into the center of the o-ring groove. On the bottom center surface of the water inlet adaptor (10) which contacts the housing is a small bleed groove (14) that is so located as to position it between the o-rings at the front of the cooler housing.

Because these bleed passages are connected to the outside, they will convey either water or oil and give a telltale warning if any of the o-rings are leaking.

##### 2. Engine Oil Cooler Removal and Disassembly

- a. Drain the cooler system.
- b. Remove turbocharger oil inlet and oil drain tube assemblies between turbocharger and cylinder block.

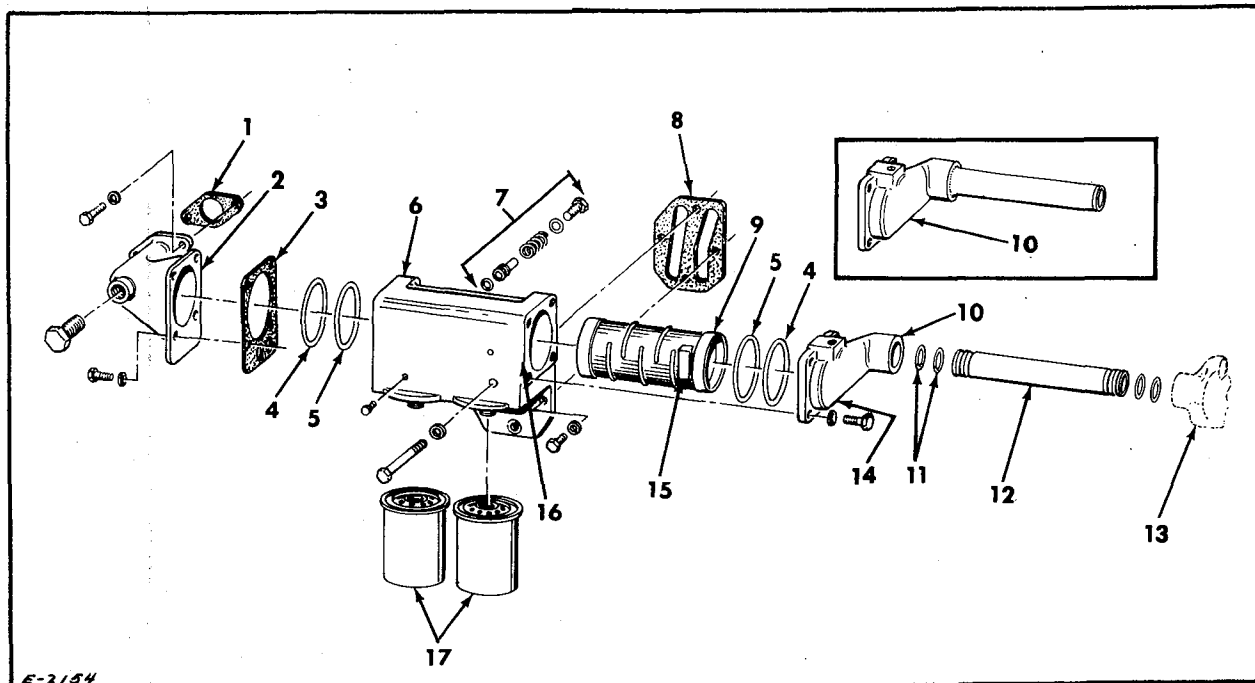

- |                                |                         |
|--------------------------------|-------------------------|
| 1. Gasket                      | 10. Water inlet adaptor |
| 2. Water outlet elbow          | 11. O-rings             |
| 3. Gasket                      | 12. Water inlet tube    |
| 4. O-ring (color code, blue)   | 13. Water pump volute   |
| 5. O-ring (color code, yellow) | 14. Bleed groove        |
| 6. Housing                     | 15. Arrow-cooler        |
| 7. Oil filter bypass valve     | 16. Arrow-housing       |
| 8. Gasket                      | 17. Oil filters         |
| 9. Cooler (tube bundle)        | 18. Bleed hole          |

Figure 4. Engine Oil Cooler and Filters

- c. Remove capscrew from fuel line clamp on top of oil cooler.
- d. If engine is equipped with a coolant heater, disconnect the electrical lead.
- e. Remove throttle and stop controls from fuel injection pump.
- f. Remove both lube oil filter (Fig 4 Item 17) elements to facilitate removal of oil cooler.
- g. If engine utilizes optional equipment it may be necessary to remove the optional assemblies and/or components.
- h. Remove capscrews and lockwashers that secure oil cooler housing (6) and water outlet elbow (2) to cylinder block. Pull cooler slightly outward and to the flywheel housing.
- i. Remove coolant tube (12) from water pump volute (13).
- j. Place oil cooler assembly on a bench and remove capscrews and lockwashers that secure coolant inlet adaptor (10) and outlet elbow (2) to housing (6).
- k. Remove tube bundle (9) from cooler housing. Discard all o-rings and gaskets.
- l. Remove oil bypass valve assembly (7) consisting of capscrew, copper washer, spring and plunger, from cooler housing.
- m. Clean and inspect tube bundle, cooler-filter housing and bypass valve parts.

### 3. Engine Oil Cooler Cleaning

Thorough cleaning of the oil cooler may require use of special solvents. Several solvents for this purpose are available and must be used according to manufacturer's instructions. Some of the solvents are:

Excello Floor Cleaning Compound  
Turco Cleaning Compound  
No. 70 Stripper  
Mixture of 3 parts Oakite No. 7 and  
5 parts fuel oil  
Bendix Cleaning Compound

To use the last-named solvent, merely submerge oil cooler into the solution for a sufficient length of time to allow chemical action of the solvent to dissolve or loosen sludge or other foreign matter. Flush oil cooler thoroughly with live steam or spirits after cleaning, regardless of type of cleaner used.

NOTE: If oil cooler core is badly clogged, a new oil cooler core must be installed.

#### 4. Engine Oil Cooler Testing

Before testing the oil cooler, it must be cleaned thoroughly and inspected. To test the oil cooler, proceed as follows:

- a. Make up two suitable plates to cover the ends of the cooler core. Drill and tap one plate to accept an air hose. Drill holes in the corners of the plates for long through bolts. Using heavy gasket material or sheet rubber to seal the ends, assemble the plates to the cooler core.
- b. Attach an air hose to the drilled and tapped plate; submerge the oil cooler in hot water for a sufficient length of time until the oil cooler is up to approximately 150° (339 K) temperature. Test for leaks with air pressure of 200 psi (1379 kN/m<sup>2</sup>) or as near to that pressure as possible.
- c. Air bubbles observed at any of the tubes indicates that the cooling core has a puncture or may be defective in another way. If the cooling core is faulty, it must be replaced.

#### 5. Engine Oil Cooler Assembly

- a. Place cooler housing (Fig 4 Item 6) in a vertical position with end having the cast arrow (16) to the top.
- b. Install one blue (water) o-ring (4) and one yellow (oil) o-ring (5) in lower end of cooler housing.

CAUTION: Blue o-ring must be toward water outlet elbow end of cooler housing.

- c. Lubricate o-rings and O.D. of cooler headers.

CAUTION: Use only a vegetable base oil such as castor oil or liquid vegetable oil (Wesson, Liquid Crisco, etc.).

- d. Install cooler tube bundle (9) and align name plate arrow (15) or locating boss with cast arrow (16) on housing within ± 0.250" (± 6.35 mm).
- e. Install yellow o-ring (5) in upper section of housing.
- f. Lubricate o-ring groove in inlet adaptor (10) and install blue o-ring (4).
- g. Assemble water inlet adaptor to cooler housing and tighten capscrews securely.
- h. Assemble water outlet elbow (2) and gasket (3) to rear of cooler housing and tighten capscrews securely.
- i. Install oil pressure bypass valve (7) and torque to 30-40 lb-ft (41-54 Nm).
- j. For ease of installation, cement new oil inlet and outlet gasket (8) to backside of housing and gasket (1) to flange of water outlet elbow (2).

#### 6. Engine Oil Cooler Installation

- a. Install new o-rings (Fig 4 Item 11) on water tube (12) and install one end of the water tube into water pump volute (13).

NOTE: In some engine applications the water inlet tube is welded into adaptor (10).

- b. Install oil cooler assembly by positioning the water inlet adaptor at rear end of water tube and pushing forward.
- c. Install capscrews and lockwashers that secure cooler assembly to cylinder block and tighten capscrews securely.
- d. If applicable install coolant heater and connect electrical lead.
- e. If engine utilized optional equipment, install by a direct reversal of the removal procedure.
- f. Complete oil cooler installation by reversing the removal procedure.

- g. Install new oil filter elements.
- h. Fill cooling system.
- i. Operate engine and check for oil and coolant leaks at oil cooler connections. Correct any leaks found. Stop engine and check oil level in oil pan; add oil if necessary to raise oil level to the full mark on the dipstick. Check coolant level in the radiator and add coolant if necessary.

## I. THERMOSTATS

The bypass type thermostats are so positioned in the system that when closed, coolant flow from the engine to the radiator is completely shut off. Coolant is then directed from the engine through the water bypass tube to the inlet side of the water pump, then back through the engine circulating system. This provides for rapid and even temperature increase of all engine parts during the warm-up period. When the specified operating temperature is exceeded, the thermostats open and allow the coolant to circulate through both the engine and radiator.

Operation of the engine with coolant temperature below 180° (355 K) will result in incomplete fuel combustion, higher fuel consumption with less power, and cause harmful deposits to form within the engine. Maintenance of normal coolant operating temperature depends on properly functioning thermostats. If the engine overheats or does not reach and maintain a minimum 180°F (355 K), remove and test the thermostats.

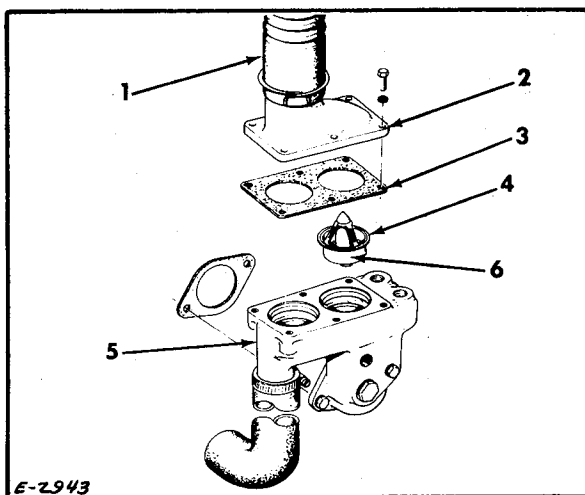

- 1. Upper radiator hose
- 2. Flange-water outlet
- 3. Gasket
- 4. Thermostat
- 5. Thermostat housing
- 6. Arrow

Figure 5. Thermostat and Housing

## 1. Thermostats Removal

- a. Drain cooling system (refer to preceding Paragraph E.)
- b. Remove capscrews and lockwashers that secure the water outlet flange (cover) (Fig 5 Item 2) to the top of the thermostat housing.
- c. Raise the water outlet flange (2) with hose (1) intact and position it to one side.
- d. Remove the outlet flange gasket (3) and thermostat (4).
- e. Clean and inspect thermostat housing.

## 2. Thermostats Testing

- a. Suspend thermostat in a container of clean water. Thermostat must be completely immersed but not touching the sides or bottom of the container.
- b. Heat water gradually and stir so heat is evenly distributed.

CAUTION: Check temperature of water with a reliable thermometer. Do not overheat.

- c. Observe thermostat as temperature of water increases. If the thermostat is functioning properly, it should begin to open between 175° to 182°F (353 to 356 K) and be fully open at 202°F (368 K). The amount of travel between open and closed positions of the thermostat should be a minimum of .266" (6.75 mm).
- d. The thermostats are not adjustable. If it does not operate within the above limits it must be replaced.

## 3. Thermostats Installation

- a. Install the thermostat/s (4) in the housing (5) with arrow (6) stamped on thermostat pointing up.
- b. Use a new outlet flange (cover) gasket (3) and position it over the thermostat/s and onto the thermostat housing (5).
- c. Inspect water outlet flange (2) and clean if necessary.
- d. Position water outlet flange on thermostat housing and secure with lockwashers and capscrews. Tighten capscrews securely.

## J. BELTS AND ADJUSTMENT

The alternator and water pump, as well as the fan mounted on the water pump pulley, are driven simultaneously by the crankshaft pulley with a identical, matched pair of belts (Fig 6).

NOTE: If unit is equipped with air compressor, removal of the air compressor drive belt is necessary before alternator/water pump drive belts may be removed. Refer to Air Compressor Topic for procedure to remove belt.

1. Inspect drive belts frequently.
2. Replace belts if they are damaged, badly worn, or soaked with oil and grease. Even though only one belt may need replacement because of damage or excessive wear, it is imperative that both belts be replaced to obtain satisfactory belt life. After replacement, approximately 24 hours operating time is required to properly seat a new pair of belts.
3. Check tension of each drive belt using a Borroughs Tension Gauge (BT-33-74) or equivalent. New drive belts are installed with a tension of 110 pounds (49.8 kg). Belts must be retightened whenever tension drops to 85 pounds (38.5 kg). Always retighten belts to 105 pounds (47.6 kg).
4. To obtain proper belt tension, loosen the alternator adjusting brace capscrew and mounting screw and move alternator in or out as required.

CAUTION: When adjusting belt tension, apply force against stator laminations between alternator end frame, not against the end frame.

5. Retighten the capscrew.

## K. COOLING SYSTEM CONDITIONER

### 1. General

The cooling system conditioner (Fig 7) extends engine life by establishing and maintaining a rust, scale, and corrosion free cooling system.

The water conditioner element is an all purpose type element and can be used with water and all types of permanent and non-permanent antifreezes, with the exception of Dowtherm 209. Refer to Parts Manual for the element to be used with Dowtherm 209.

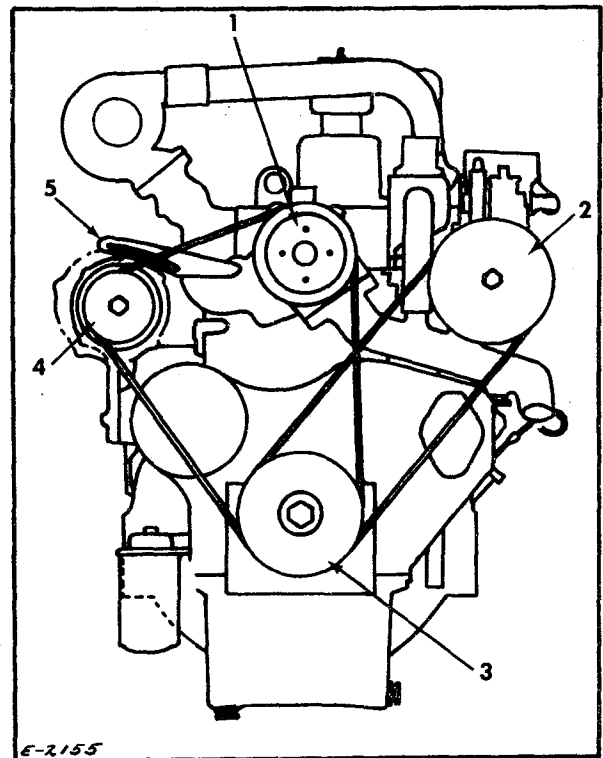

1. Water pump pulley
2. Compressor pulley
3. Crankshaft pulley
4. Alternator pulley
5. Adjusting brace

Figure 6. Belt Adjustment

CAUTION: Whenever element is changed from one type element to the other, it is necessary to drain and flush the cooling system.

The coolant conditioner performs the following functions:

- a. It provides by mechanical filtration, a coolant free of dirt, sludge, and other foreign matter.
- b. It prevents precipitation of water hardness scale on all cooling system surfaces by the ion exchange method of water softening.
- c. The chemicals present in the water conditioner element protect against corrosion activity in the engine.
- d. Electrolytic control is accomplished by the use of a sacrificial plate.
- e. The natural tendency toward rust

formation and chemical deterioration of cooling system metal surfaces is reduced by the effective buffering agents contained in the element.

**CAUTION:** Do not use soluble oil or other conditioners in the cooling system of an engine equipped with a coolant filter. If a leak stopper is added to the coolant, do not allow it to circulate through the water conditioner. Shut-off valves are provided in inlet and outlet lines for isolating the water conditioner from remainder of cooling system.

## 2. Maintenance

At each 600 hour interval of operation, depending on conditions, maintain the coolant conditioner as follows:

**NOTE:** Change initial coolant conditioner element at 100 hours.

- a. Thoroughly clean base and surrounding area.
  - b. Close coolant inlet and outlet shut-off valves.
  - c. Remove exhausted spin-on element and discard.
  - d. Lubricate gasket with a thin film of oil.
  - e. Install element until gasket contacts base of mounting housing.
  - f. Hand tighten 1/2 turn more.
  - g. Open inlet and outlet shutoff valves.
  - h. Operate engine and check for leaks.
- ## 3. Removal and Installation
- a. Close coolant conditioner inlet and outlet shutoff valves.
  - b. Remove outlet hose between top conditioner mounting base and thermostat housing.
  - c. Remove inlet hose between side of conditioner mounting base and cylinder block.
  - d. Remove lockwashers, washers and capscrews that secure coolant conditioner mounting base to the cylinder block and remove mounting base.

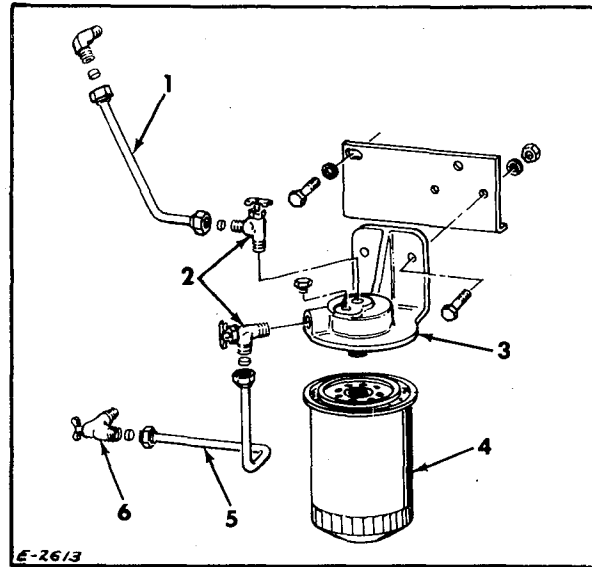

1. Tube - to thermostat housing
2. Shutoff valves
3. Header
4. Coolant filter/conditioner
5. Tube - from cylinder block
6. Two way valve - cylinder block drain

Figure 7. Cooling System Conditioner

- e. Remove hose fittings from inlet and outlet of coolant conditioner mounting base.
- f. Inspect coolant conditioner hoses for deterioration or damage. Replace if necessary.
- g. Install hose fittings in coolant conditioner inlet and outlet openings.
- h. Install coolant conditioner base and secure with capscrews, washers, and lockwashers.
- i. Install hoses on fittings and tighten hose securely.
- j. Install new coolant conditioner element.
- k. Open coolant conditioner inlet and outlet shutoff valves.
- l. Check coolant level; add coolant if necessary.
- m. Operate engine and check for leaks.

## TOPIC 12. FUEL SYSTEM

### A. GENERAL

The standard fuel system consists of a fuel tank, single throw-away type fuel filter, hand primer pump, fuel transfer pump, fuel injection pump, fuel injection nozzle-holder assemblies and low and high pressure systems.

In areas where fuel contaminated with water is a problem or improper storage and handling of fuel on the job site results in the fuel being contaminated with water, it is recommended to include in the fuel system, an option equipment fuel and water separator.

The low pressure system is comprised of the fuel tank, water separator, filter, hand primer pump, transfer pump, fuel lines between the fuel tank and the fuel pump and fuel return lines.

The high pressure system begins in the fuel injection pump where the fuel is forced by the action of cam-actuated plungers into the outlet ports and through the high pressure fuel lines connected to the fuel injection nozzles.

The fuel is drawn from the fuel tank through the water separator, filter, and primer pump by the transfer pump located at the rear of the fuel injection pump. The fuel is then forced by the transfer pump to the cam-actuated plungers which force the fuel under high pressure through the fuel lines to the fuel injection nozzles from which the fuel enters the combustion chambers in the form of four, fine, cone-shaped sprays.

The fuel transfer pump delivers more fuel to the fuel sump of the injection pump than is

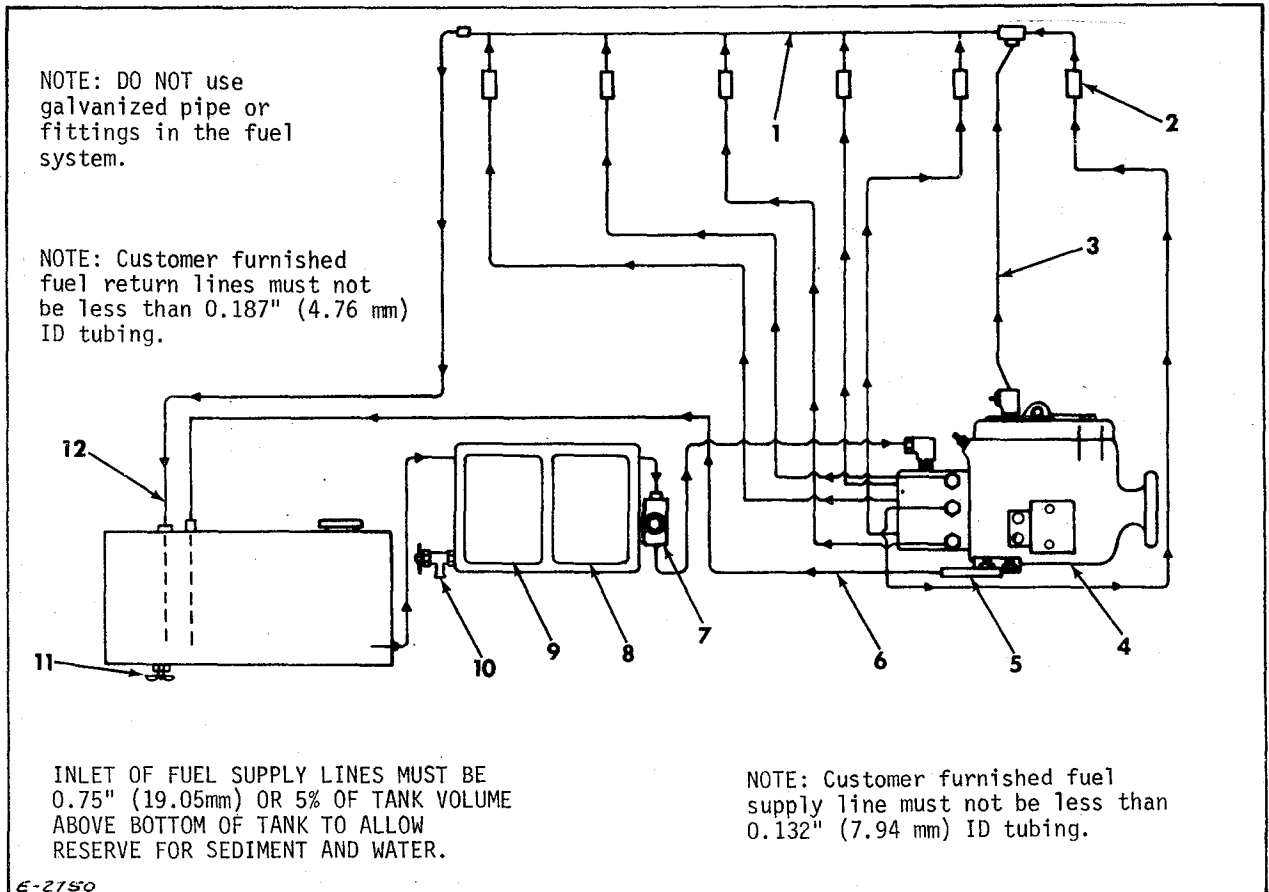

- |  |                                |
|--|--------------------------------|
| 1. Drip manifold                             | 7. Hand primer pump            |
| 2. Nozzle holder assembly                    | 8. Fuel filter                 |
| 3. Manifold to injection pump line           | 9. Water separator (optional)  |
| 4. Fuel injection pump                       | 10. Separator water drain cock |
| 5. Accumulator (optional hydraulic governor) | 11. Tank drain cock            |
| 6. Return line from accumulator              | 12. Fuel return line           |

Figure 1. Fuel System Schematic Diagram

required for engine operation. A fuel return line conveys surplus fuel back to the fuel tank.

There is a certain amount of fuel seepage between the lapped surfaces of each fuel injection nozzle valve and its body, which is necessary for lubrication. This leakage of fuel accumulates around the spindle and in the spring compartment of each fuel injection nozzle holder and is returned through the fuel drip manifold to the fuel return line, extending to the fuel tank.

A regulating valve in the pump end plate allows a large percentage of the fuel to be bypassed back to the inlet side. The fuel bypassed increases in proportion to speed, and the regulating valve is designed so the transfer pump pressure also increases with speed.

If necessary precautions are not taken in the storage of fuel, in the transfer of fuel to the fuel tank, and in keeping the fuel tank full to prevent condensation, foreign matter and water will enter the fuel system and damage the fuel injection pump and fuel injection nozzles. The fuel filter is installed in the fuel injection system to clean the fuel before it enters the fuel injection pump.

It is essential that personnel responsible for the care and operation of the engine adhere to the following maintenance recommendations:

1. Use only fuel meeting the specifications as outlined in Topic 7.
2. Store and handle fuel with utmost care to prevent water and foreign matter from entering the fuel system.
3. Properly maintain fuel oil filter.
4. Remove injection nozzle holder assemblies at the prescribed intervals; adjust the opening pressure and check the spray pattern.
5. Daily drain the water from the optional fuel and water separator and from the fuel tank. Check the fuel supply.
6. Periodically check injection pump timing.
7. Keep all fuel line connections, filter, injection pump and injection nozzle holder assemblies tightened securely to the engine (specified torque).
8. Before removing any part of the fuel injection system from the engine be sure to wash the part with cleaning solvent, also the surrounding area to prevent the entrance of abrasives into the system. Cover all openings immediately.

## B. FUEL FILTER AND OPTIONAL FUEL AND WATER SEPARATOR

The fuel filter (Fig 2) is a disposable, throw-away type. The filtering media within the filter prevents dirt and sediment from entering the fuel injection pump.

### 1. Filter Maintenance

Inspect components of the filtering system for leaks and make the necessary repairs to eliminate them.

Renew the filter each 600 hour interval of operation, or more often when operating conditions warrant, or when filter becomes clogged. A clogged filter is usually indicated by irregular engine performance.

The design of the water separator is such that it does not need replacement unless it is accidentally damaged. Drain water daily from separator or when it reaches a maximum depth of 0.750" (19.50 mm).

### 2. Filter Replacement (Renewal)

The filtering system (Fig 2) consists of an optional water separator assembly mounted on a common base with a throw-away type filter assembly. The filter consists of two sections of pleated paper filtering media in series and packaged in a heat resistant glass case.

The water separator consists of a nylon stretch sock with one end closed and the other end enclosing the fuel inlet opening. A perforated aluminum baffle encloses the sock to prevent it from covering the fuel outlet opening. All fuel passes through the porous surface of the sock which diffuses the fuel flow, reducing its rate of flow. Water droplets are repelled by the nonwetting surface of the nylon sock and tend to collect into large drops which are eventually forced through weave of the sock. These larger drops due to the reduced rate of fuel flow settle to the bottom of the separator. The water level in the separator must not exceed 3/4 full.

All openings in the filter and separator are fitted with grommets to seal them to the base. A hollow locating pin is positioned in the base for the filter and separator so that they cannot be installed incorrectly. A spring type clamp retains each unit in position on the base.

A hand primer pump is connected to the outlet of the filter and is used to



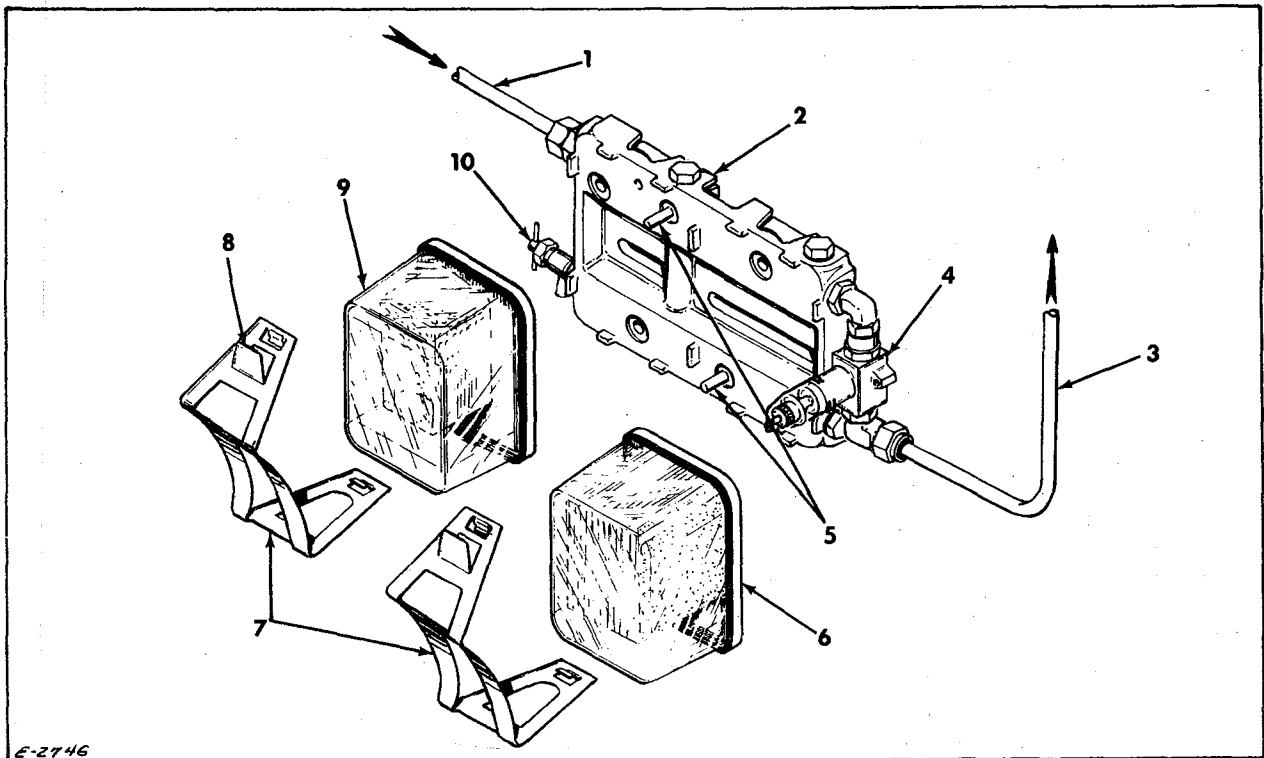

- |                      |                  |                               |
|----------------------|------------------|-------------------------------|
| 1. From fuel tank    | 4. Primer pump   | 8. Clamp top                  |
| 2. Filter base       | 5. Locating pins | 9. Water separator (optional) |
| 3. To injection pump | 6. Fuel filter   | 10. Drain cock                |
|                      | 7. Clamps        |                               |

Figure 2. Standard Fuel Filter and Optional Water Separator

purge air from the system after a new filter is installed or after performing other service repairs.

Remove and install the filter or water separator as follows:

- a. Remove dirt from around filter, and water separator base and surrounding area.

NOTE: Close fuel tank shutoff valve if fuel level in tank is above level of fuel filter.

- b. With thumb and forefinger squeeze the protrusions at the top of the clamp, lifting up and moving the clamp away from the filter or water separator.
- c. Remove the filter or water from the base.
- d. Inspect and clean base.
- e. Position filter or water separator on its locating pin.

- f. Hook lower end of clamp on base and force top into position.

- g. Refer to Paragraph C and prime the fuel system.

#### C. PRIMING THE FUEL SYSTEM

The procedure for priming the fuel system is as follows:

##### 1. Priming Low Pressure System

- a. Due to the water separator (Fig 2 Item 9) and the filter (6) being on the suction side of the hand primer pump (4) and the transfer pump at the rear of the injection pump, make certain all plugs and line fittings are tight otherwise air will be drawn into the system when the hand primer pump or injection pump is activated.
- b. Loosen the injection pump end of the fuel supply tube between the hand primer pump and the injection pump.
- c. Make certain there is fuel in the tank and the tank shutoff valve is



open.

- d. Loosen locking screw on top of hand primer (4) pump plunger and move clamp to one side.
- e. Move primer plunger back and forth in a pumping motion to fill the filter with fuel and expel the air.
- f. When flow of fuel around line nut is free of air bubbles, tighten nut securely.
- g. Position primer pump plunger clamp and retighten locking screw.

## 2. Priming High Pressure Fuel System

The high pressure fuel system is usually selfpriming due to the fact that air trapped by the fuel injection pump is forced out through the injection nozzles and into the combustion chambers. However, if the engine has run out of fuel or has been shut down for an extended period of time, or if the fuel lines have been removed, it may be necessary to prime the high pressure system to facilitate engine starting. Proceed as follows:

- a. Loosen fuel line connecting nut attaching each line to its corresponding fuel nozzle holder.
- b. Place speed control in high speed position and place stop control in the RUN position.
- c. Press starter switch and crank engine with starting motor until fuel flows from ends of all high pressure fuel lines. Connect fuel lines to nozzle holders and tighten connection nuts.

CAUTION: Do not operate starting motor continuously for more than 30 seconds at a time without a pause of two minutes to permit starter to cool.

## D. FUEL INJECTION PUMP

Purpose of the pump is to accurately meter and deliver quantities of fuel under high pressure to injection nozzles through which the fuel is introduced into the engine combustion chambers at a definite timing in relation to the engine firing cycle and within the required injection period.

The distributor type fuel injection pump, incorporates inlet metering and opposed plungers that are operated by an internal cam ring. It is designed for self-lubrication by the fuel oil supply. The generator drive engine in-

jection pump governor has an adjustable 3-1/2 to 5% speed droop regulation governor and is the automatic speed advance type.

A fuel injection pump with a governor having hydraulic features and adjustable 1 - 5% speed droop regulation is available as an optional. This pump does not have the automatic speed advance device.

Both governor are of the mechanical-centrifugal type which controls fuel delivery and, therefore, engine speed. The governor is driven directly off of the pump drive shaft without gearing. The direction of rotation of the drive shaft is clockwise.

The transfer or supply pump, in the opposite end of the rotor from the pumping cylinder, is of the positive displacement, vane type and is covered by the end-plate.

Fuel shutoff is accomplished by de-energizing the fuel shutoff solenoid. The electric solenoid mechanism within the fuel pump opens or closes the metering valve to permit or stop the flow of fuel to the engine. The electric solenoid mechanism is the energized to run type (open when energized).

The governor is lubricated by fuel oil and seldom needs adjustments. If engine speed is irregular, check all other components in the fuel system and other applicable engine adjustments before removing the injection pump for repairs.

CAUTION: To prevent internal damage to the fuel injection pump, make certain the governor speed control lever is secured in its high-idle - no load speed position before removing fuel injection pump from the drive shaft. At this position, governor spring tension will hold the governor weights in place after the fuel injection pump is removed from the drive shaft. Otherwise it is possible for the governor weights to be jarred out of the governor weight retainer sockets whenever an injection pump is handled without the drive shaft installed. Wire the governor speed control lever in the high idle - no load speed position before removing the fuel injection pump.

## 1. Fuel Injection Pump Removal

- a. Clean external surfaces of the injection pump, including all line connections and fittings that are to be disconnected to prevent dirt from entering system.
- b. Rotate engine flywheel until Number 1 piston is near top of its compression

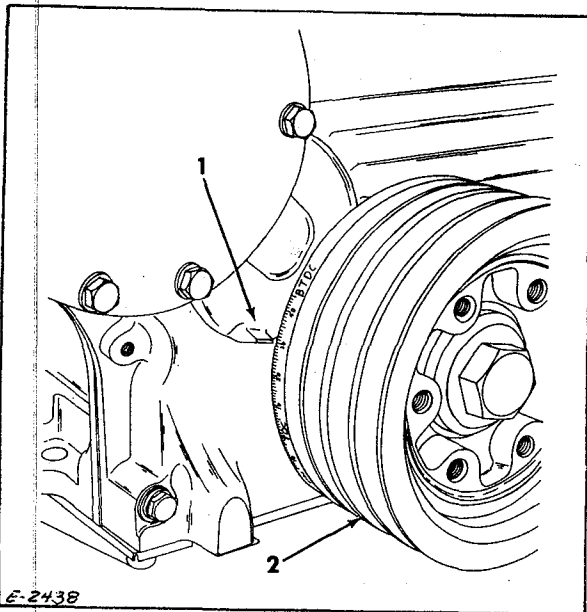

1. Timing pointer
2. Crankshaft pulley and damper assembly

Figure 3. Front End Timing Marks

stroke and pointer on timing gear cover is aligned with specified number of timing degrees stamped on the crankshaft pulley. Refer to Topic 2, Paragraph D, for timing degrees per engine rpm.

- c. If applicable remove the throttle from the governor speed control lever (Fig 9).
- d. Disconnect electrical leads from terminals on fuel pump cover (Fig 10).
- e. Shut off fuel supply if the tank or fuel level in tank is above the filter.
- f. Disconnect and remove filter-to-fuel-pump inlet line.
- g. Disconnect and remove fuel line between injection pump and drip manifold.
- h. Disconnect all fuel injection lines from nozzle holders and fuel pump. Loosen, but do not remove, nuts securing two clamps on the fuel injection lines. Remove lines and loosened clamps as an assembly from the engine. Cover all openings to prevent entrance of dirt.
- i. Remove adaptor-to-pump stud nuts and serrated washers. Remove fuel injection pump assembly from the drive

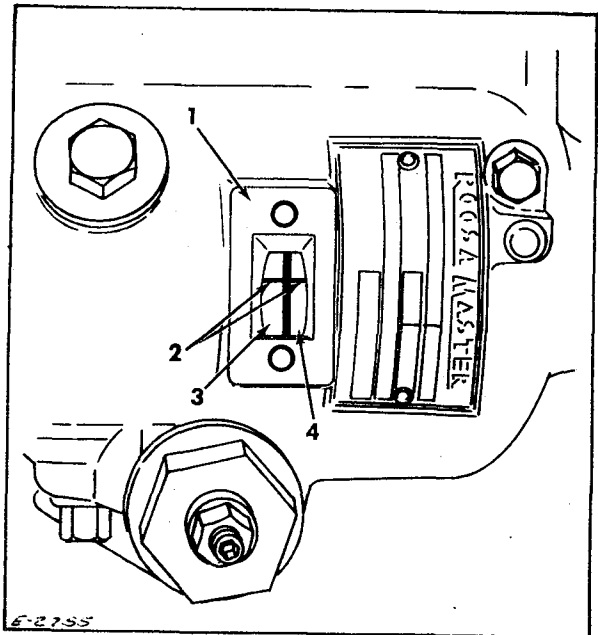

1. Timing windows
2. Timing marks
3. Cam ring
4. Governor weight retainer

Figure 4. Fuel Pump Timing Marks

shaft, being careful not to damage drive shaft seals.

## 2. Fuel Injection Pump Installation And Timing

When the fuel injection pump has been serviced and is ready to be installed, or if a new pump is to be installed on the engine, follow the procedure outlined below:

- a. If the engine was not rotated from its position since the injection pump was removed as indicated in preceding Subparagraph 1, the engine is properly positioned for installation of the injection pump. If the engine was rotated or has been overhauled, make certain the #1 piston is on its compression stroke. This may be determined as follows:
  - (1) Remove the cylinder head cover so valve action can be observed.
  - (2) Rotate engine flywheel until #6 cylinder exhaust valve is nearly closed and #6 cylinder intake valve is just beginning to open. This will position #1 piston near the top on its compression stroke.
  - (3) Continue rotating the flywheel until

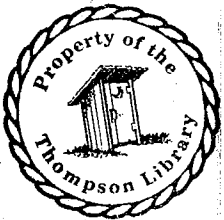

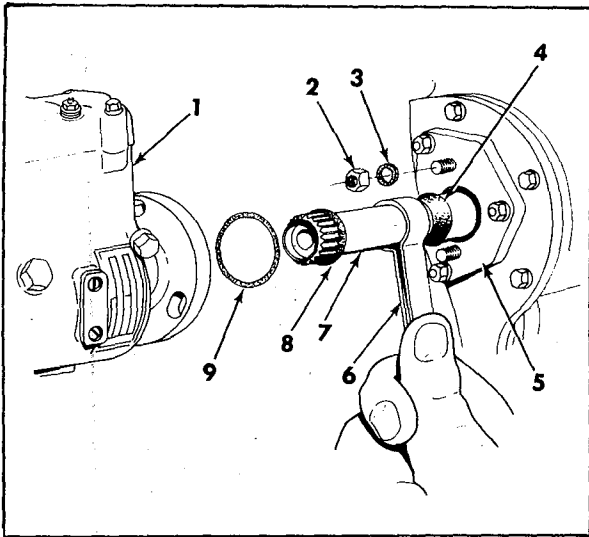

1. Injection pump
2. Nut
3. Serrated washer
4. Shaft seals
5. Adaptor
6. Seal compressor tool
7. Drive shaft
8. Pilot seal
9. Drive shaft end seal

Figure 5. Installing Fuel Injection Pump

the timing pointer (Fig 3) is aligned with the specified number of degrees BTDC stamped on the crankshaft pulley. Refer to Topic 2, Paragraph D, for specified number of timing degrees per engine rpm.

**NOTE:** To be sure that all slack is out of the timing gears, back up the engine several degrees and again come up to the timing mark in the direction of normal engine rotation (clockwise when viewed from the front). The engine is now in correct position for beginning of fuel injection into number one cylinder and for installing the fuel injection pump or for checking its timing.

- b. Inspect pump drive shaft seals (Fig 6 Item 5), drive shaft end seal (6) and pilot seal (7). Replace if necessary.
- c. Remove timing window cover from the fuel injection pump. Two fuel pump timing marks (Fig 4) are used for timing injection of fuel into number 1 cylinder. One mark is located on governor weight retainer hub and one is located on the cam ring. Insert

screwdriver, or other suitable tool, into drive shaft end of pump and turn distributor rotor until timing marks are aligned as viewed through the timing window.

**NOTE:** Before aligning pump timing marks, check to make certain the distributor rotor turns freely. If it does not, it is possible one or more of the governor weights is not properly positioned in the governor weight retainer and the injection pump must be disassembled to correct this condition.

- d. Lubricate drive shaft seals with engine oil. Hold fuel pump in position so vertical center line of pump is approximately in line with scribed mark on flange. Slide pump over drive shaft and on to pump mounting studs using a seal compressor tool similar to the one illustrated in Figure 5 to prevent damage to seals. Install serrated washers and the adaptor-to-pump stud nuts but do not tighten nuts at this time.

**CAUTION:** In order to prevent installation of fuel pump 180° out of time, an internal groove (Fig 6 Item 8) is provided in the splined end of the pump drive shaft. The splined end must be engaged by an internal tang (2) of the fuel pump distributor rotor before drive shaft will engage distributor rotor splines.

- e. Turn pump until timing marks are aligned. Tighten attaching stud nuts securely to a torque of 18 to 21 lb-ft (24 to 28 Nm).

**NOTE:** Mounting holes in pump housing are elongated so pump can be turned to align timing marks within the timing window.

- f. Install timing window cover and gasket.
- g. Install fuel injection lines to nozzle holders and fuel injection pump.

**NOTE:** Use a new fuel line connector gasket on both sides of each injection line fitting at injection pump.

- h. Tighten injection line clamp capscrews and nuts.

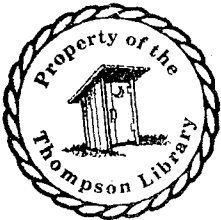

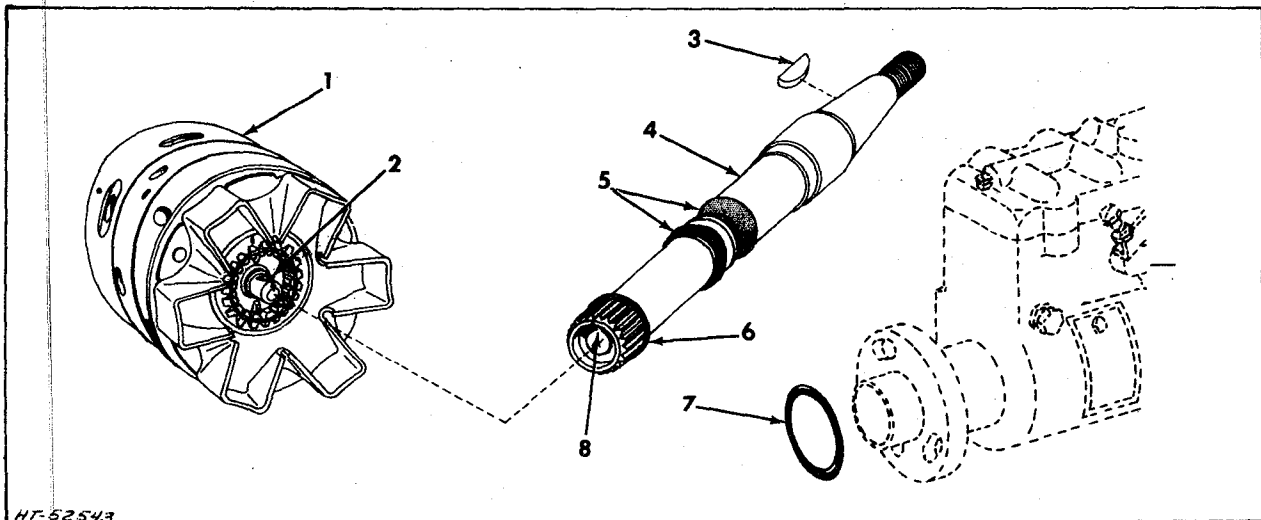

HT-52543

- |                                      |                         |
|--------------------------------------|-------------------------|
| 1. Hydraulic head and rotor assembly | 5. Drive shaft seals    |
| 2. Internal tang                     | 6. Drive shaft end seal |
| 3. Key                               | 7. Pilot seal           |
| 4. Pump drive shaft                  | 8. Internal groove      |

Figure 6. Fuel Pump Drive Shaft, Head and Rotor, and Seals

- |   |   |
|---|---|
| <ul style="list-style-type: none"> <li>i. Install fuel line between injection pump and drip manifold.</li> <li>j. Install filter-to-fuel-pump inlet line. Tighten capscrews securing fuel filter head to cylinder block.</li> <li>k. If fuel supply valve was previously shut off, open the valve.</li> <li>l. Connect electrical leads to terminals on fuel pump cover.</li> <li>m. If applicable connect speed control cable to speed control lever.</li> <li>n. Prime fuel system as detailed in preceding Paragraph C.</li> </ul> <p>3. Checking Automatic Advance</p> <p>The function of the automatic advance, is to advance the timing automatically as the engine speed increases. Injection pumps with the hydraulic type governor do not have the automatic advance device.</p> <p>If the automatic advance is stuck in the full advance position the engine will be hard to start, but will pull its load at rated rpm.</p> <p>If the advance device does not advance the timing, the starting characteristics will be normal but when the load is applied at rated rpm there will be excessive black smoke in the exhaust and a noticeable lack of power.</p> | <p>A quick method to determine if the speed advance is operating properly is as follows:</p> <ul style="list-style-type: none"> <li>a. Remove the timing window cover and install a plastic timing window (Fig 7).</li> <li>b. Check the static timing of the injection pump to the engine. The pump is properly timed to the engine when the pump timing marks (Fig 8 Items 2 and 3, View "A") are aligned and the timing pointer (Fig 3) is aligned with the 24° mark on the crankshaft pulley.</li> <li>c. Crank the engine with the starter and with the throttle in the full load position. At cranking speed there should be no movement of the timing mark on the cam ring (Fig 8 Item 3).</li> <li>d. Operate the engine until operating temperature is reached. Apply load at full load rpm and observe the pump timing mark on the cam ring (Fig 8 Item 3, View "B"). The automatic advance is operating properly if the timing mark moves downward.</li> </ul> |
|---|---|

NOTE: The timing mark on the governor weight retainer hub (Fig 8 Item 2) will not be visible because the assembly is rotating at one-half engine speed.

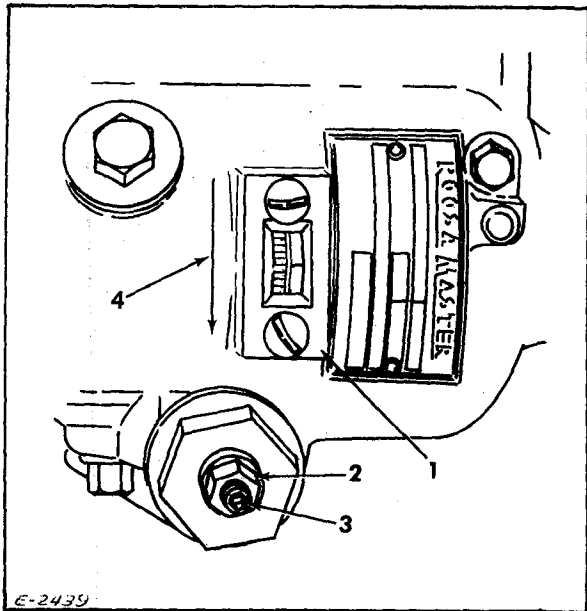

1. Plastic timing window
2. Locknut
3. Timing advance adjusting screw
4. Direction of advance

Figure 7. Timing Window Installed on Injection Pump With Automatic Advance

- e. Remove plastic timing window and install timing window cover.

The recommended methods to check or adjust the automatic advance is with the engine connected to a dynamometer so that the specified full load can be applied to the engine or the injection pump removed from the engine and mounted on a pump test stand so it can be adjusted according to the pump test specifications.

#### 4. Fuel Injection Pump Adjustments

Most Allis-Chalmers dealers are equipped with injection pump test stands and the special tools required for testing, adjusting, and repairing this assembly. If at any time the pump and governor assembly requires repair or adjustment, it should be removed and taken to an Allis-Chalmers dealer. It is important that the dealer be furnished with the pump serial number, as well as engine model and serial number, to facilitate repair.

### E. GOVERNOR

#### 1. General

The fuel injection pump contains its own

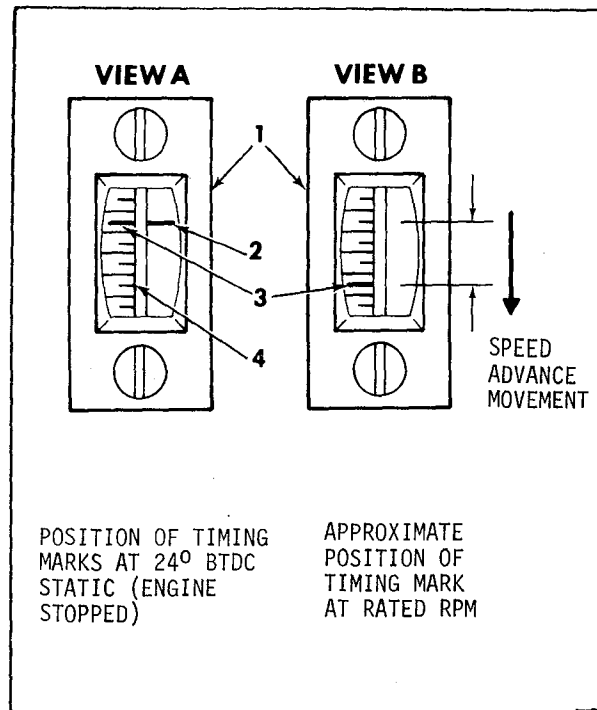

1. Plastic timing window
2. Timing mark on weight retainer hub
3. Timing mark on cam ring
4. Graduations on timing window

Figure 8. Checking Automatic Advance Device

mechanical or flyweight-type governor which controls the amount of fuel delivered to the engine. The movement of the flyweights against the governor thrust sleeve rotates the metering valve. The rotation varies the position of the metering valve slot with the fuel passage to the rotor, controlling the flow of fuel. The governor is adjusted at the factory to provide for the proper horsepower at full-load governed speeds. The idle speed is adjusted to 1400 rpm.

The generator drive engines have an adjustable 3.5 to 5% speed droop regulation governor as standard. A hydraulic type governor with 1 to 5% adjustable speed droop regulation is available as optional equipment.

All engines leaving the factory are equipped with fuel injection pumps and governors that have been carefully calibrated, adjusted, and sealed. No lubrication service on the governor assembly is required and it seldom needs adjustment. If engine speed is irregular, check the fuel system and applicable engine adjustments before changing the governor setting. Refer to Topic 2, Paragraph F, for standard speed settings.

Generator sets which are not intended for parallel operation with another generator set have the governor speed control lever (Fig 9 Item 3) locked at the full-load speed position by tightening the high speed adjusting screw (2) and the low speed adjusting screw (4) against their stops on the side of the injection pump.

If the generator set is equipped with paralleling equipment, a vernier (coarse and fine adjustment) type throttle or a speed control motor (Fig 9) is applied to the engine.

## 2. Engine Speed Adjustment

### a. Checking Engine Speeds

- (1) Run engine until minimum operating temperature of 160°F (344 K) obtained.
- (2) Check engine speed with an accurate tachometer.

NOTE: Use a stroboscope type tachometer to check engine speed. Make an rpm count of the crankshaft pulley or the main alternator rotor shaft.

### b. Speed Adjustment - Locked-Up Governor Speed Control Lever Type

- (1) Loosen the low speed and high speed adjusting screw locknuts. (Fig 9 Items 1 and 5)
- (2) Back off the low speed adjusting screw (4) 1 or 2 turns.
- (3) Hold speed control lever (3) toward rear (away from fan end) of engine so that the high speed adjusting screw (2) contacts the lever stop (7). Turn the adjusting screw IN to decrease high idle engine speed. When the proper high speed is obtained, hold the speed control lever tight against the high speed stop and tighten the low speed adjustment screw (4) to secure the lever in position.
- (4) Tighten the low and high speed adjusting screw locknuts.
- (5) Again, check the high speed rpm. If necessary, repeat steps (1) thru (4).

### c. Speed Adjustment - Throttle Type

- (1) Run engine until minimum operating temperature of 160°F (344 K) is obtained.

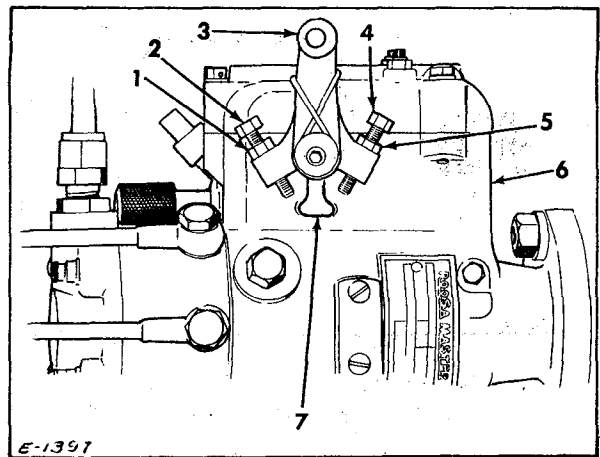

1. Locknut
2. High speed adjusting screw
3. Speed control lever (spring loaded)
4. Low speed adjusting screw
5. Locknut
6. Fuel injection pump
7. Lever stop

Figure 9. Engine Speed Adjustment

- (2) Disconnect throttle cable from fuel injection pump speed control lever (Fig 9 Item 3) so lever can be moved by hand.
- (3) With engine running, loosen locknut on the low speed adjusting screw. Hold speed control lever toward front (fan end) of engine so low idle adjusting screw contacts the lever stop. Turn low speed adjusting screw IN to increase or OUT to decrease low idle engine speed. When specified rpm is obtained, hold adjusting screw and tighten the locknut.
- (4) Again with engine running, loosen locknut on the high speed adjusting screw. Hold speed control lever toward rear (away from fan end) of engine so high speed adjusting screw contacts the lever stop. Turn high speed adjusting screw IN to decrease or OUT to increase high engine speed. When proper high speed is obtained, hold adjusting screw and tighten the locknut.
- (5) Connect throttle cable to the speed control lever. Make certain lower end is so positioned in the control cable bracket and swivel that the throttle will move the governor speed control lever from the low speed stop to the high speed stop.

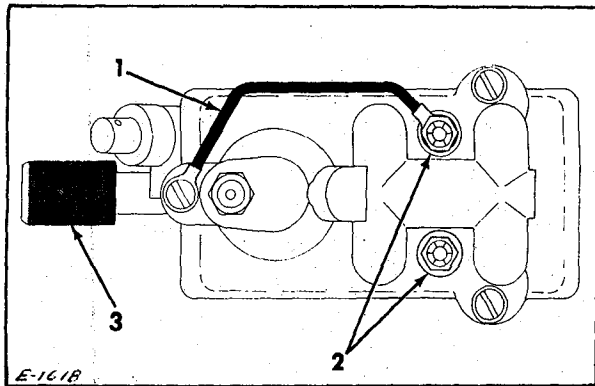

1. Ground wire (power units only - not used with generator drive engines)
2. Electric fuel solenoid terminals
3. Speed droop adjusting screw

Figure 10. Speed Droop Adjustment

3. Governor Adjustments - Standard 3.5 to 5 Per Cent Regulation

An external speed droop adjustment screw at rear of the pump housing (Fig 10) provides precision control of governor sensitivity by decreasing or increasing effective length of the governor control spring. Turning the adjusting screw IN shortens effective length of the control spring, making it less sensitive and increasing the speed droop. Turning the screw OUT has opposite effect. Adjust governor as detailed below:

- a. Make low speed and high idle speed adjustments following procedure outlined above.

NOTE: Adjust generator drive engines to the low speed specified by the generator set manufacture.

- b. To adjust speed droop:

- (1) Operate engine until minimum operating temperature of 160°F (344 K) is reached.
- (2) Apply full load. With engine operating at rated speed, droop is determined by removing load and noting the no-load speed, or in the case of a generator set, by noting its frequency.
- (3) Turn adjusting screw (Fig 10 Item 3) clockwise to increase, or counter-clockwise to decrease speed droop. A minor correction to the full load may be necessary.

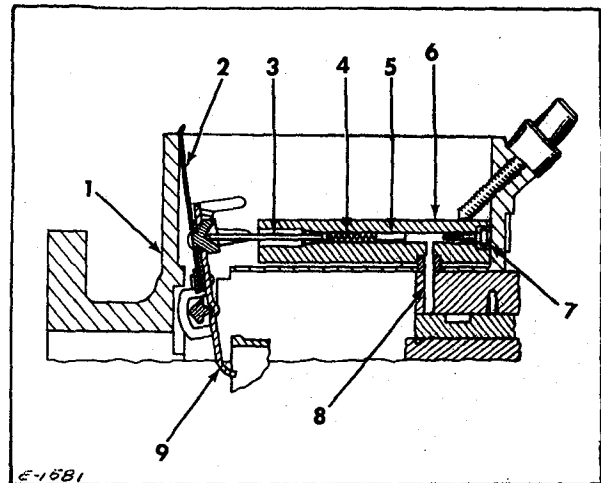

- |                    |                       |
|--------------------|-----------------------|
| 1. Pump body       | 5. Piston             |
| 2. Bi-metal spring | 6. Hydraulic cylinder |
| 3. Piston rod      | 7. Seal               |
| 4. Spring          | 8. Boost passage      |
|                    | 9. Governor arm       |

Figure 11. Hydraulic Governor Cylinder

4. Optional Governor - 1 to 5% Regulation

This governor has features similar to the standard governor such as flyweights and external speed droop adjustment, however, the speed droop is adjustable from 1 to 5%.

A hydraulic booster device augments the mechanical governor in the pump. The booster is actuated by fuel pump pressure and, through a servo acts directly on the mechanical governor arm within the pump body (Fig 11).

A spring-loaded piston-type accumulator (Fig 11) prevents hunt at light loads by providing a lag to the hydraulic governor response.

CAUTION: The end of the accumulator must be piped separately back to the fuel tank. (See Figure 1 Item 6).

To offset temperature vibrations which affect governor spring rate and hydraulic governor leakage, a special bi-metal spring (Fig 11 Item 2) is employed. It is attached to the front of the governor arm within the pump body.

At low fuel temperatures the compensating spring opposes the main governor spring. As temperature of the fuel increases the compensating spring force reduces, off-setting main governor spring rate change. Thus speed and generator



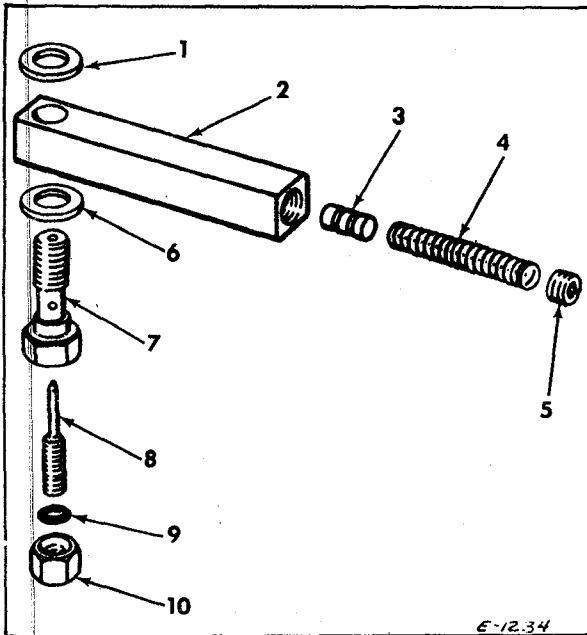

1. Gasket
2. Accumulator
3. Piston
4. Dampening spring
5. Spring stop screw
8. Accumulator adjusting screw
9. Adjusting screw seal
10. Adjusting screw locknut

Figure 12. Accumulator Assembly

frequency remain constant.

The combination of the mechanical and hydraulic features of the governor results in excellent stability.

All engines leaving the factory are equipped with fuel injection pumps and governors that have been carefully calibrated, adjusted, and sealed. No lubrication service on the governor assembly is required and it seldom needs adjustment. If the engine speed is irregular, check the fuel system and applicable engine adjustments before changing the governor setting. Refer to Topic 2, Paragraph F, for standard speed settings.

#### a. Adjustments

Checking the speed settings, adjusting speed settings, and making the speed droop adjustment are done in

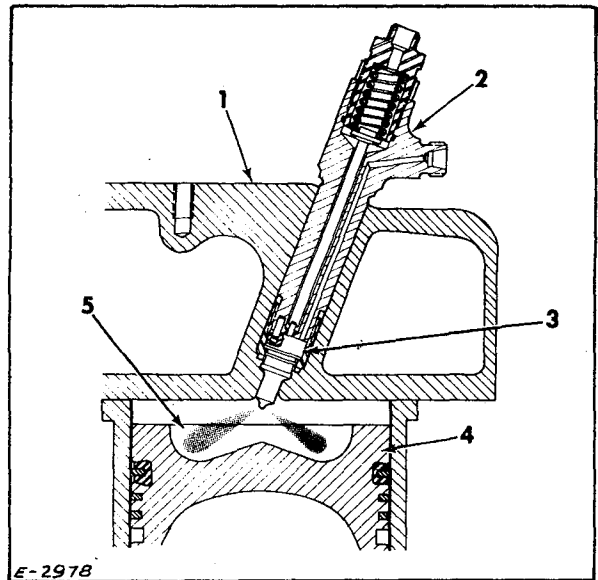

1. Cylinder head
2. Fuel injection nozzle holder assembly
3. Fuel injection nozzle
4. Piston
5. Combustion chamber

Figure 13. Combustion Chamber and Nozzle Holder Location (Typical)

an identical manner as the standard 3.5 to 5% regulation governor, Paragraph 3 above.

#### b. Accumulator

The accumulator adjusting screw (Fig 12) is adjusted at the factory and should never require further adjustment unless a new or rebuilt fuel injection pump is installed on the engine. Adjustment is required only if a rapid surge of small intensity at light load is noted after the speed droop adjustment has been made.

To adjust the accumulator adjustment screw, proceed as follows:

- (1) Install and time the fuel injection pump to the engine.
- (2) Operate engine until minimum operating temperature of 160°F (344 K) is reached, and set throttle for specified no load speed.

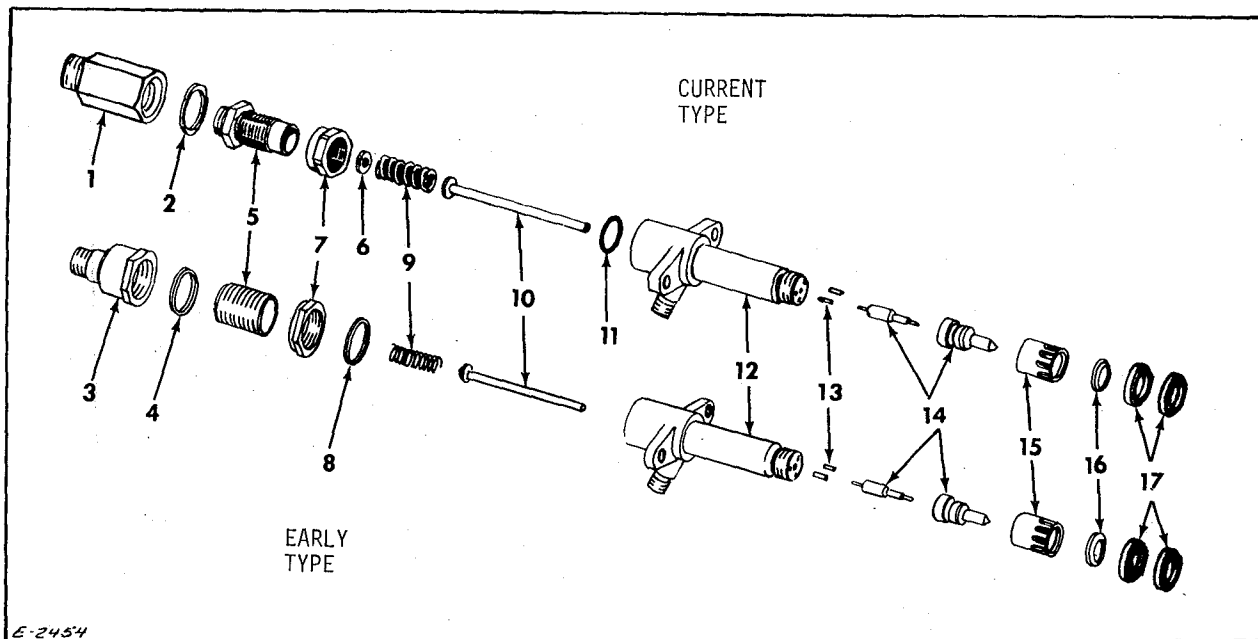

- |            |                    |                   |                                |
|------------|--------------------|-------------------|--------------------------------|
| 1. Adaptor | 5. Adjusting screw | 9. Spindle spring | 13. Dowel pins                 |
| 2. Gasket  | 6. Wear washer     | 10. Spindle rod   | 14. Nozzle body & needle valve |
| 3. Cap nut | 7. Locking nut     | 11. O-ring        | 15. Retaining nut              |
| 4. Gasket  | 8. Gasket          | 12. Holder body   | 16. Gasket                     |
|            |                    |                   | 17. Nozzle holder dust shields |

Figure 14. Nozzle Holder Assembly

- (3) Loosen accumulator adjusting screw locknut (Fig 12 Item 10). Bottom adjusting screw (8) and back out 1 - 1/4 to 1 - 1/2 turns.
- (4) Apply full load and check speed droop. Set speed droop.
- (5) Turn accumulator adjusting screw (8) to dampen surge. Turning screw clockwise decreases damping.
- (6) Again check regulation and lock accumulator adjusting screw locknut (10).

c. Bench Checks For Trouble Free Performance of Hydraulic Governor

- (1) Hydraulic governor spring (Fig 11 Item 4) and piston (5) must slide freely in hydraulic cylinder (6).
- (2) Dampening spring (Fig 12 Item 4) must slide freely in accumulator (2).

- (3) Hydraulic governor assembly must be checked for leakage by pressurizing the head locating screw hole with 40 psi (276 kN/m<sup>2</sup>) of air. The metering valve should be in the OFF position. There should be no leakage at the seal between the hydraulic head and the hydraulic cylinder.
- (4) The governor control spring which engages the two tabs on the governor and should be bent slightly into the center of the coils to prevent rocking.
- (5) The bi-metal spring for the temperature compensator must not be reshaped or bent out of position. Contact with housing must be maintained at all operating speeds.

F. FUEL INJECTION NOZZLE HOLDER ASSEMBLY

1. Description

Each engine cylinder is provided with a multihole, differential needle, hydraulically lifted, fuel injection nozzle holder assembly. The function of each nozzle holder assembly is to direct

metered quantity of fuel received from the fuel injection pump into the corresponding engine combustion chamber in a highly atomized, predetermined spray pattern, and in such manner as to produce the most efficient performance.

Each fuel injection nozzle holder assembly consists of two assemblies: an injection nozzle holder assembly and an injection nozzle assembly. The holder assembly positions the nozzle in the cylinder head and provides a means of conducting fuel received from the fuel injection pump to the nozzle.

The current holder (Fig 14) consists of a steel holder body, two locating dowels, spindle, spindle spring, wear washer, pressure adjusting screw, adjusting screw locknut, a nozzle retaining nut, and an o-ring located in an internal groove of the body spring compartment. This o-ring and the lower portion of the adjusting screw form a seal which prevents fuel oil leakage from the spring compartment.

**NOTE:** The top end of the current nozzle holder assembly is approximately 1 inch (25.40 mm) lower than the early type. When the current type is intermixed with early type nozzle holder assemblies and drip manifold, an adaptor (Fig 19 Item 1) and gasket (2) are required.

The early type nozzle holder assembly consists of a steel holder body, two locating dowels, spindle, spindle spring, pressure adjusting screw, adjusting screw locknut, gaskets, cap nut, and a nozzle retaining nut.

The nozzle assembly (Fig 14 Item 14) consists of a nozzle valve and a nozzle body in which are located four spray orifices, equally spaced 90° apart. The nozzle valve is operated hydraulically within the valve body by fuel delivered under pressure by the fuel injection pump. The nozzle is positioned on the holder by two dowels (Fig 15 Item 4) whereby the four spray orifices are fixed on a plane parallel to the piston top (Fig 13), and the nozzle fuel duct is registered with the holder fuel duct.

Fuel enters the nozzle holder fuel inlet passages, passes through the holder fuel duct into the nozzle fuel duct via an annular groove in the nozzle body, and then into the pressure chamber above the nozzle valve seat. At instant the pressure of fuel in the pressure chamber exceeds pressure exerted on

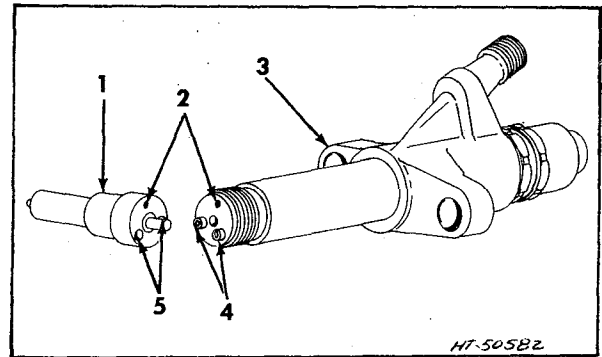

1. Nozzle assembly
2. Fuel ducts
3. Holder assembly
4. Dowels
5. Dowel holes

Figure 15. Fuel Injection Nozzle Holder Dowel Location

spindle and nozzle valve by the spindle spring, the nozzle valve is lifted off its seat and fuel is forced through orifices in the valve body end and into the corresponding engine combustion chamber. The nozzle valve is returned to its seat by pressure exerted by the spindle spring when the fuel injection pump has ceased to deliver fuel to the nozzle holder.

A certain amount of fuel seepage between the lapped surfaces of each nozzle valve and valve body is normal and necessary for lubrication. This fuel accumulates around the spindle and in the spring compartment of the fuel nozzle, and is returned through the fuel drip manifold and fuel return line to the fuel tank.

Two dust shields (Fig 14 Item 17) are installed on each nozzle holder to prevent moisture and foreign matter from entering nozzle holder bore in cylinder head.

## 2. Maintenance

After each operating interval of approximately 1300 hours, the fuel injection nozzles should be removed, cleaned, tested, and adjusted if necessary. The specified opening ("popping") pressure for model 3500 engine is 3100 to 3150 psi (21374 to 21718 kN/m<sup>2</sup>).

The opening pressure is adjusted with the pressure adjusting screw (Fig 14 Item 5). Turn the adjusting screw counter-clockwise to decrease opening pressure and clockwise to increase opening pressure. A nozzle tester with an accurate pressure gauge must be used to observe the opening pressure spray pattern and

general function of the nozzle.

### 3. Fuel Injection Nozzle Holder Removal

- a. Thoroughly clean fuel injection nozzles, lines, connectors, and surrounding area.
- b. Remove fuel drip manifold and disconnect injection lines from nozzle holder assemblies.

**CAUTION:** Do not bend lines when disconnecting. Cover all openings immediately to prevent entrance of dirt.

- c. Remove capscrews and lockwashers securing nozzles to cylinder head.

**CAUTION:** Use care when removing an injection nozzle to prevent striking nozzle tip against a hard object which could result in damage to the tip.

- d. Remove nozzles from cylinder head by using two small pry bars.
- e. Remove dust shields from nozzle holders. If dust shields are brittle, torn or deteriorated, they must be replaced. Loosen pressure adjusting screw locknut (Fig 17).

### 4. Testing and Adjusting Fuel Injection Nozzle Holder

A nozzle tester similar to the one illustrated in Figure 16 is required to properly test and adjust fuel injection nozzles.

**WARNING:** KEEP HANDS AWAY FROM NOZZLE TIP WHEN POPPING A NOZZLE. THE FINELY ATOMIZED FUEL IS EJECTED WITH SUFFICIENT FORCE TO PENETRATE THE SKIN AND CAUSE BLOOD POISONING.

Test and adjust each fuel injection nozzle as follows:

- a. Bolt or clamp base of nozzle tester to a work bench.
- b. Turn nozzle tester valve handle to the open position. Loosen filler cap to prevent air lock in the tester. Operate handle until fuel flows from end of tester fuel line, then close valve.
- c. Connect nozzle holder to fuel line of tester. Place spray collector

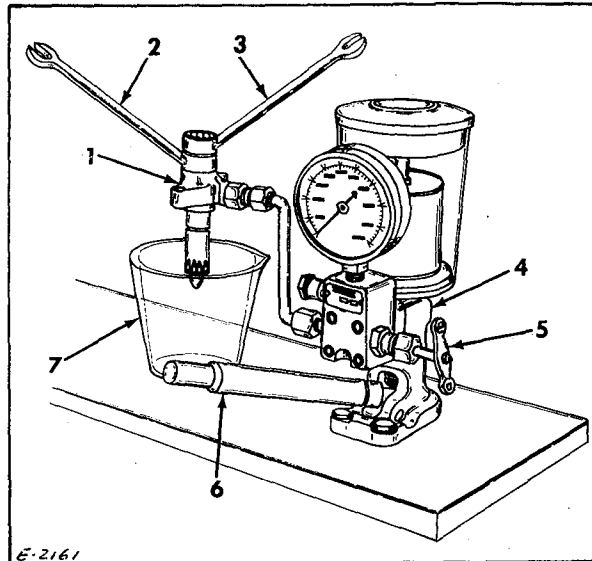

1. Nozzle holder assembly
2. Wrench-holding locknut
3. Wrench-turning adjusting screw
4. Nozzle tester
5. Valve handle
6. Tester handle
7. Spray collector

Figure 16. Adjusting Nozzle Opening Pressure

under valve end of nozzle.

- d. Open nozzle tester valve. Operate handle a few quick strokes and observe nozzle opening pressure indicated on pressure gauge. Specified nozzle opening pressure is 3100 to 3150 psi (21374 to 21718 kN/m<sup>2</sup>).
- e. Adjust fuel injection nozzle to obtain specified opening pressure as follows:
  - (1) Loosen adjusting screw locknut.
  - (2) While operating handle, turn pressure adjusting screw IN to increase or OUT to decrease opening pressure. When the specified pressure is obtained, hold adjusting screw and tighten locknut to 50 lb-ft (68 Nm) torque.
- f. Dry the nozzle tip. Operate handle slowly until pressure is approximately 200 psi (1379 kN/m<sup>2</sup>) below opening pressure. Observe nozzle tip for fuel leakage. If nozzle does not leak, the nozzle valve is seating properly in the valve body. If drops of fuel collect at a pressure of approximately 200 psi (1379 kN/m<sup>2</sup>), or less, below opening pressure, the nozzle valve is not seating properly. In this case, the valve body and valve must be re-

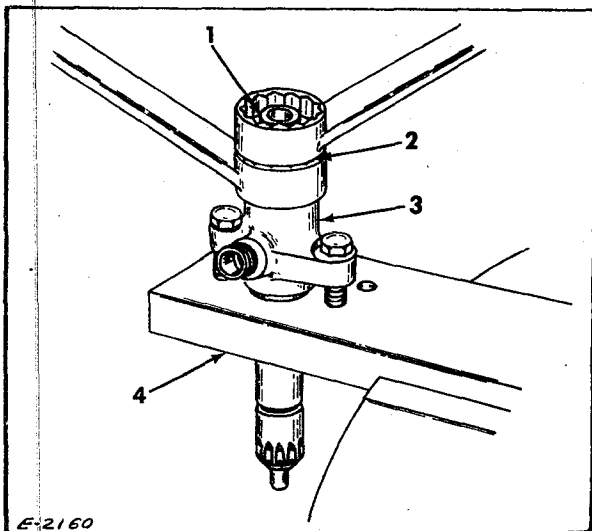

1. Adjusting screw
2. Locknut
3. Nozzle-holder assembly
4. Holding fixture

Figure 17. Loosening Pressure Adjusting Screw Locknut

moved for cleaning and inspection.

- g. If the nozzle proved satisfactory when subjected to the leakage test above, operate handle at a speed of approximately 100 strokes per minute and observe nozzle spray pattern.
- h. The nozzle tip has 4 equally spaced holes, 90° apart. Size and spacing of these holes determines the spray pattern. If fuel is discharged evenly through all 4 holes at the specified opening pressure, the spray pattern is considered satisfactory (Fig 18).
- i. If the fuel is not discharged evenly from all 4 holes, a plugged hole(s) is indicated, in which case, the nozzle must be removed and cleaned using a proper size cleaning wire (Fig 19). Refer to Paragraph D of Topic 2 and Paragraph C of Topic 8 for cleaning wire size and tool part number.
- j. To remove nozzle from holder, loosen pressure adjustment locknut (Fig 14) to relieve tension on spindle rod, then remove nozzle retaining nut and nozzle.
- k. Install new or cleaned nozzle on holder and tighten retaining nut to 50 lb-ft (68 Nm) torque.
- l. Connect nozzle holder assembly to tester and adjust nozzle opening pressure to

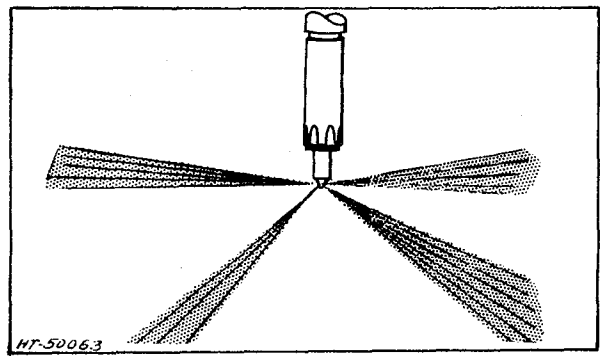

Figure 18. Acceptable Spray Pattern

3100 - 3150 psi (21374 to 21718 kN/m<sup>2</sup>).  
Tighten adjusting screw locknut to 50 lb-ft (68 Nm) torque.

#### 5. Installation of Fuel Injection Nozzle Holder Assembly

- a. Thoroughly clean nozzle holder bores in cylinder head. When cleaning bores, make certain old nozzle holder gaskets are removed because new gaskets must be used when installing the nozzle holders. Make sure no small particles of carbon are in nozzle holder bores that could prevent nozzle holder gaskets from seating properly thereby permitting "blow-by" from the cylinders.
- b. Install dust shields (Fig 14 Item 17) on nozzle holder (12) and place new nozzle gasket (16), concave face toward the cylinder head in position on nozzle.

NOTE: Coat nozzle holder body with neverseize compound to prevent seizure in cylinder head.

- c. Carefully position nozzle holder in nozzle bore of cylinder head. Install nozzle holder lockwashers and capscrews for each nozzle but do not tighten at this time. Place fuel injection tubes in position in nozzle holders. Start injection tube nuts but do not tighten at this time. Install fuel drip manifold.
- d. Tighten nozzle holder capscrews alternately. Tighten capscrew on one side to 6 lb-ft (8 Nm) torque. Tighten capscrew on opposite side to full specified torque 13 lb-ft (18 Nm). Then tighten first capscrew to full specified torque.
- e. Tighten injection tube and drip manifold nuts securely.

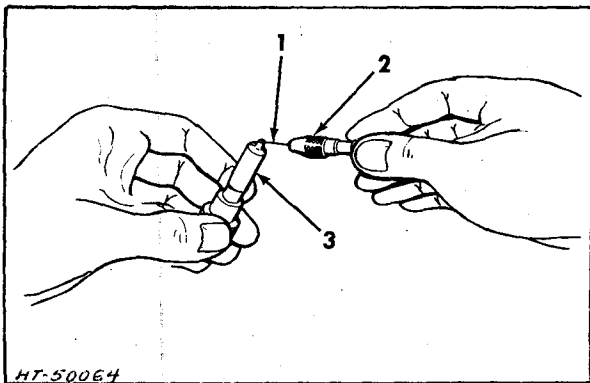

1. Cleaning wire
2. Pin vise
3. Valve body

Figure 19. Cleaning Nozzle Orifices

- f. Start engine and observe fuel injection tubes and fuel drip manifold connections for fuel leakage. Correct all leaks found.

### G. REMOVING CARBON FROM FUEL INJECTION NOZZLE BORE

If the cylinder head has been removed from the engine, it is advisable to remove carbon deposits, from the nozzle holder to cylinder gasket seat and the nozzle bores within the cylinder head. Use a tool similar to the one illustrated in Figure 20.

**CAUTION:** Under no circumstances should an engine be operated with a leaking or "blow-by" nozzle holder because localization of heat will occur that will distort the nozzle holder and result in serious damage.

### H. CHECKING FUEL SYSTEM

Missing or uneven running of the engine, excessive vibration, stalling when idling, and loss of power are indications of insufficient fuel supply to the engine. Before making any of the following checks, make certain there is an ample supply of clean fuel in the fuel tank and that the fuel tank shutoff valve is open.

**CAUTION:** The following tests require the engine to be operated at speeds below 1450 rpm. If the engine is powering a generator set, the main generator voltage regulator must be disconnected from the system to protect it from damage at the lower speeds.

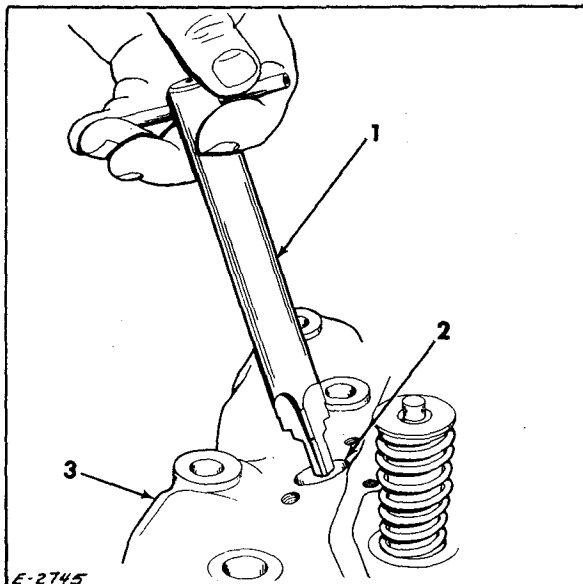

1. Carbon removing tool
2. Fuel injection nozzle bore
3. Cylinder head

Figure 20. Removing Carbon From Fuel Injection Nozzle Bore

#### 1. Check for Admission of Air Into System

Remove fuel return line from fitting in the injection pump cover. Insert length of hose on the fitting. Place other end of hose in a container partially filled with fuel oil. Run engine at approximately 1000 rpm and observe end of hose in container for bubbles. Occasional bubbles are permissible, however, excessive bubbling or foaming indicates air is being drawn into the system. Correct this condition by tightening any loose low pressure fuel line connections and filter connections.

#### 2. Check for Clogged Fuel Filter and Clogged or Collapsed Fuel Lines

A clogged filter or restriction(s) in fuel lines will cause loss of power, engine stalling, or erratic operation. A simple method of eliminating these troubles is to remove the fuel filter, blow out all low pressure fuel lines with filtered compressed air, and install a new filter. Another method is to install a vacuum gauge at the inlet and also one at the outlet of the fuel filter. Pressure drop across a clean filter should not exceed 1.5 in to 2.5 in (0.0517 to 0.0863 kg/cm<sup>2</sup>) of mercury at full load speed. A pressure drop 10 in (0.345 kg/cm<sup>2</sup>) of mercury indicates filter is

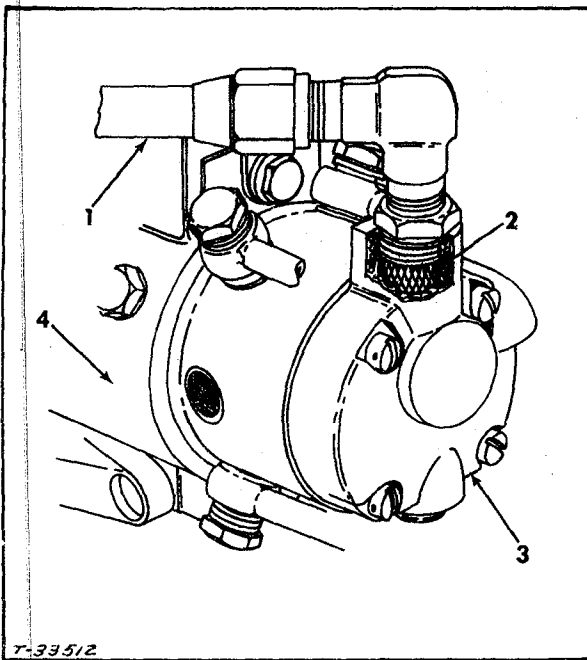

1. Filter to pump inlet line
2. Strainer
3. End plate
4. Fuel injection pump

Figure 21. Fuel Strainer Location

loaded and should be replaced. If a 10 in (0.345 kg/cm<sup>2</sup>) mercury pressure drop is still obtained when a new filter is used, inspect all low pressure lines for clogging, crimping, etc., and clean or replace as required.

To check high pressure lines between fuel pump and fuel injection nozzles, start engine and loosen each line nut, one at a time, at the nozzle holders. If no fuel is observed at the loosened line nut, line may be clogged, crimped, or cracked. In any case, it must be replaced.

Check fuel strainer (Fig 21) in end plate of injection pump. Remove foreign material if screen is clogged.

### 3. Check for Inoperative Fuel Transfer Pump

If engine is still erratic after making checks detailed in Steps 1 and 2 above, check operation of the fuel transfer pump and end plate pressure regulating valve. Run engine until normal operating temperature is reached, then shut it down. Remove plug marked OUT in bottom of end plate opposite fuel inlet, and install a pressure gauge. With key switch in OFF position and speed control in IDLE position, crank engine with the starter. Minimum pressure should be 6 psi (41 kN/m<sup>2</sup>) at 150 rpm cranking speed.

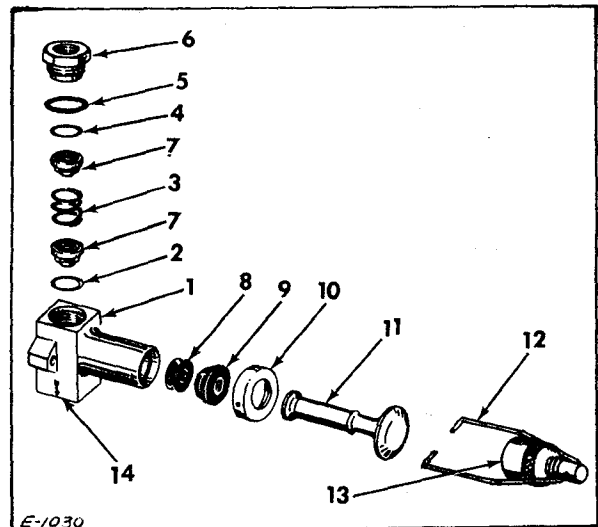

- |                        |                            |
|------------------------|----------------------------|
| 1. Body                | 8. Piston seal             |
| 2. Valve gasket        | 9. Plunger guide           |
| 3. Spring              | 10. Retaining cap          |
| 4. Valve nut seal      | 11. Plunger                |
| 5. Valve nut seal ring | 12. Clamp                  |
| 6. Valve nut           | 13. Clamp screw            |
| 7. Valve               | 14. Direction of fuel flow |

Figure 22. Hand Primer Pump

If pressure is less than 6 psi (41 kN/m<sup>2</sup>) check for malfunction in end plate and transfer pump parts.

### 4. Check for Inoperative Fuel Injection Nozzles

Missing or uneven running of engine and loss of power are indicative of an inoperative fuel injection nozzle(s). To locate a faulty fuel nozzle, use following procedure:

- a. Run engine at low idle speed and "cut out" each fuel nozzle in turn by loosening line nut attaching fuel injection line to its corresponding fuel nozzle.
- b. A decrease in engine speed with line nut loosened indicates fuel nozzle for that cylinder is functioning properly. If engine speed does not decrease, the fuel nozzle is inoperative and should be repaired or replaced.

### 5. Check for Inoperative Fuel Injection Pump

Do not replace the fuel injection pump before making a compression test. The compression test is used to detect burned or stuck valves, worn or scored pistons/sleeves, worn or stuck rings, etc., that cause faulty engine operation.

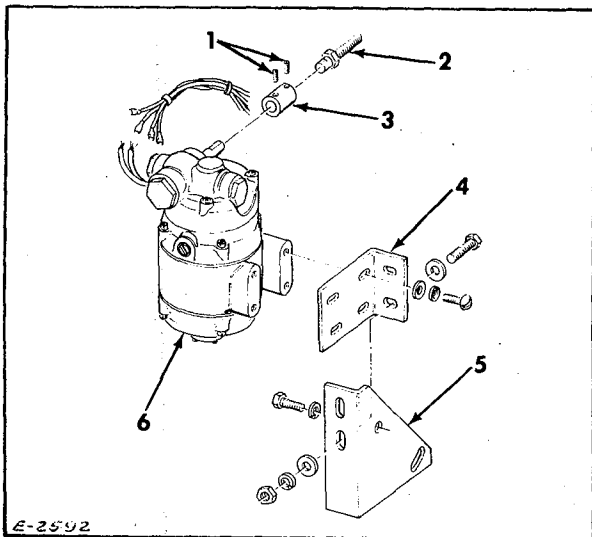

- |                           |                  |
|---------------------------|------------------|
| 1. Setscrews              | 4. Motor bracket |
| 2. Throttle control screw | 5. Bracket       |
| 3. Coupling               | 6. Motor         |

Figure 23. Speed Control Motor Mounting

If all possible causes for insufficient fuel supply have been eliminated and the engine still runs unevenly, and normal engine performance is not obtained, the fuel injection pump may be at fault and should be checked, repaired or replaced. The faulty fuel injection pump should be taken to your nearest Allis-Chalmers dealer for testing and repair.

**IMPORTANT:** Do not replace the fuel injection pump until making certain that all other possible causes for improper engine operation have been eliminated.

### I. HAND PRIMER PUMP

The main function of the hand primer pump is to force air from the fuel system which enters when the engine runs out of fuel, the fuel filters are renewed, or from servicing the injection pump.

#### 1. Disassembly

- a. Unscrew the clamp screw (Fig 22 Item 13) and swing clamp (12) off plunger (11).
- b. Spread clamp wire (12) ends to disengage from body (1). Remove plunger (11), guide (9), and piston seal (8), and retaining cap (10) as an assembly.
- c. Place body (1) in a soft-jaw vise and remove nut (6), seal ring (5), valve seal (4), upper valve (7), spring (3), second valve (7), and valve gasket.

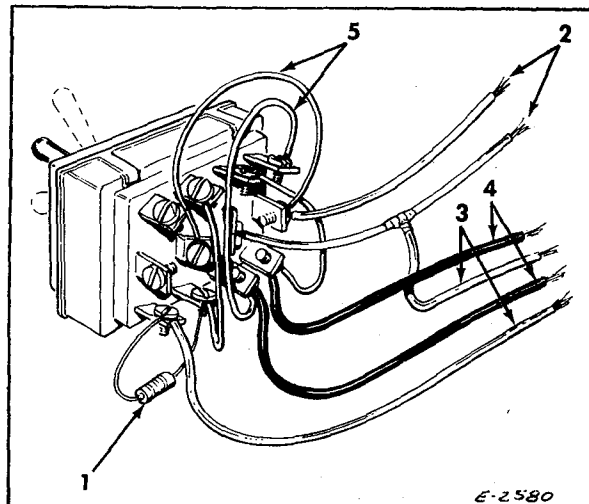

1. Resistor
2. Source 24 V.DC
3. Blue lead motor armature
4. Black lead motor coil
5. Jumper

Figure 24. Wiring Diagram (Speed Control Switch)

**NOTE:** Hand primer pumps of early manufacture had paper gaskets instead of current type valve gasket (2) and the valve seal (4). If the valve nut is reusable, replace it using paper gasket.

#### 2. Inspection

- a. Examine valve gaskets for tears and replace as needed. Check piston seal (8) on bottom of plunger (11) for damage, and replace if necessary. Check for foreign matter in valves (7) and body (1).
- b. If rubber plunger guide (9) is worn, cut it for removal from plunger (11).

#### 3. Assembly

- a. Position retaining cap (10) on plunger (11). Using clean grease to lubricate, slip plunger guide (9) onto plunger with the chamfered side down. Position piston seal (8) on end of plunger.
- b. Assemble lower valve gasket (2) in pump body (1). The two valve (7) are identical; place one of them in the body followed by the valve spring (3) and the second valve. Make certain the valves are positioned in the body so that they open in the direction of the arrow (14) on the side of the pump body.



- c. Assemble valve nut seal (4), valve nut seal ring (5), and valve nut (6). Tighten nut securely.
- d. Assemble plunger with piston seal, and plunger guide in pump body.
- e. Align holes in plunger retaining cap with holes in body. Spread clamp wire ends and insert them in cap and body.
- f. Position clamp over plunger and tighten clamp screw.

#### J. SPEED CONTROL MOTOR

##### 1. General

An electrically controlled motor (Fig 23) to regulate engine speed is available as an option. When the engine is equipped with a speed control motor, the manually operated SPEED CONTROL mounted on the engine control panel is eliminated. The speed control motor is activated by a two position toggle switch (Fig 24).

##### 2. Operation

The shaft of the speed control motor is connected directly to the throttle shaft of the fuel injection pump by a flexible coupling. The motor is either 12 or 24 volt dc, 4 lead, reversible, shunt type with speed reduction gears. It is activated by the two position toggle switch. Putting the switch in the RAISE position will increase engine speed and, conversely, placing it in the LOWER position will decrease engine speed.

##### 3. Maintenance

The motor is lubricated for life. The setscrews securing the coupling to shafts of the motor and fuel injection pump must be kept tight to avoid straining the shafts. The holes in the motor support bracket are elongated so that alignment of the motor and coupling with the shaft in the fuel injection pump can be maintained without any strain on the shaft.

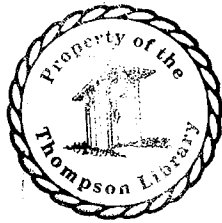

## TOPIC 13. LUBRICATION SYSTEM

### A. GENERAL

The engine is pressure lubricated by an oil pressure pump. The pump is driven by the oil pump driving gear in mesh with the crankshaft gear.

The standard oil pan is designed to permit engine operation at angles up to 30°, optional equipment oil pans are available to meet applicable engine applications. Refer to Topic 2, Paragraph C, for optional oil pans angle of operation. With the engine operating at full

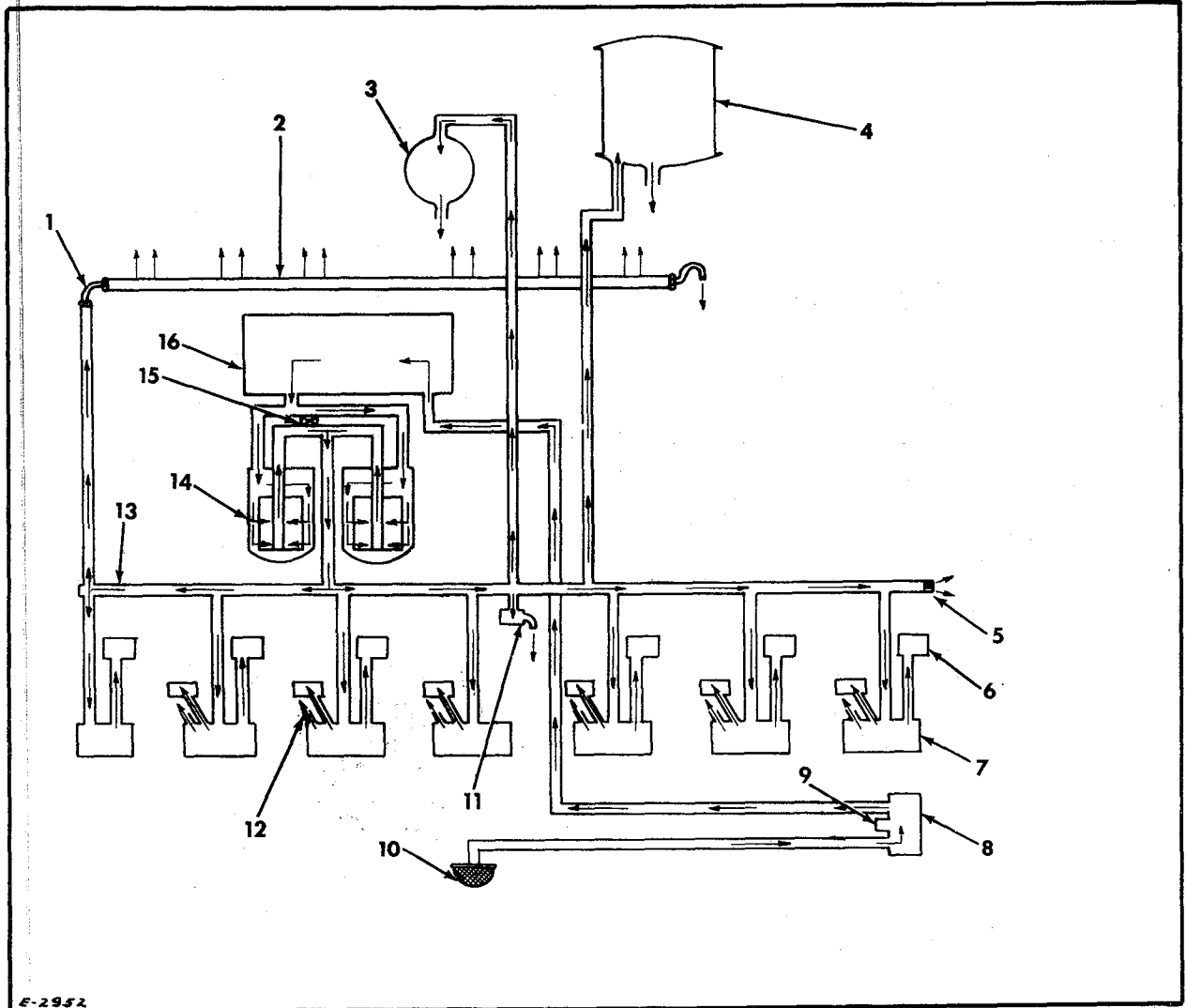

- |                                      |                               |                                   |
|--------------------------------------|-------------------------------|-----------------------------------|
| 1. 1/16" (1.59mm) elbow restrictor   | 7. Crankshaft main bearing    | 11. Oil pressure regulating valve |
| 2. Rocker arm shaft                  | 8. Standard oil pressure pump | 12. Piston cooling jet            |
| 3. Turbocharger                      | 9. Relief valve               | 13. Main oil gallery              |
| 4. Oil filter-bypass type (optional) | 10. Oil pressure pump suction | 14. Oil filter-full flow type     |
| 5. 3/32" (2.38mm) restrictor         |                               | 15. Pressure relief valve         |
| 6. Camshaft bearing                  |                               | 16. Oil cooler                    |

Figure 1. Lubrication System Schematic Diagram

speed and with the coolant at normal operating temperature, the engine oil pressure should range between 30 and 55 psi (207 and 379 kN/m<sup>2</sup>).

Cooling of the pistons is accomplished by directional jets located in the upper main bearing support member of the cylinder block. These jets direct a metered amount of oil to the underside of the piston domes. Oil is routed to the jets by a passage (hole) which is connected to the annular oil groove in the main bearing.

To maintain clean oil in the system, 2 full flow, throw-away type filters are mounted on the bottom of the oil cooler housing. To supplement these filters, an optional large capacity, bypass type filter is connected into the system.

## B. GENERAL MAINTENANCE

The level of the lubricating oil in the oil pan must be checked with the engine in a level position at the start of each period of operation.

The oil level gauge (dipstick) is shielded to allow the operator to check the oil level with the engine either stopped or running at idle speed. The gauge is stamped to indicate the two different oil levels. The RUNNING side is stamped ADD, FULL and RUNNING. The STOPPED side is stamped ADD, FULL, and STOPPED (Fig 2).

To check the oil level with the engine stopped, use the side of the dipstick marked STOPPED. If the engine is stopped after a period of operation, allow at least 5 minutes for the oil to drain into the oil pan before checking the oil level.

If the oil level is low, add lubricating oil, as specified in Topic 6, to bring the level of the oil to the FULL mark on the gauge.

Once the engine has started, observe the engine oil pressure gauge. If the engine is cold, wait for several seconds for the pressure gauge to indicate normal pressure. If after a few seconds, the gauge does not indicate normal pressure, stop the engine and correct the cause.

**CAUTION:** Never operate an engine with the oil pressure below the specified minimum. Failure to observe this caution will result in damage to the engine.

After starting a turbocharged engine, it is extremely important that it be allowed to idle for 3 to 5 minutes without racing. Permitting the engine to idle assures free circulation of lubricant through the turbocharger bearings.

Allowing the turbocharger to operate at high

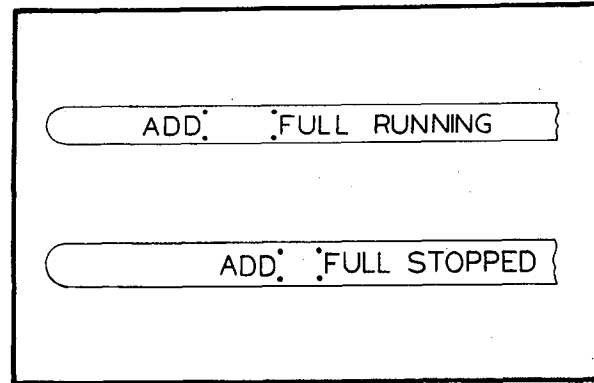

Figure 2. Oil Level Gauge

speed without sufficient lubrication can result in turbocharger bearing failure within 30 seconds.

It is equally important that all engines be allowed to operate at a fast idle for 5 minutes before shutting down. Permitting the engine to idle assures an even cooling of components and allows the turbocharger speed to be minimal when the supply of lubricant is cut off.

Maintenance personnel should familiarize themselves with the recommended lubrication change periods specified in Topic 8 and with the recommended lubricant specified in Topic 6.

## C. FULL-FLOW LUBRICATING OIL FILTERS

### 1. General

Engine mounted lubricating oil filters (Fig 3) are the full flow, throw away type. They are screwed onto threaded inserts in the bottom of the oil cooler housing which forms the mounting header and contains the oil passages which convey the oil to the filters and clean oil to the main gallery in the cylinder block. A spring loader bypass valve connected into these passages permits unfiltered oil to bypass the filters and go direct to the main gallery if the filters become clogged, or if the oil becomes too thick in cool weather to circulate freely through the filters.

### 2. Maintenance

- Operate engine until coolant is at minimum operating temperature. Remove plug from side of oil pan and let oil drain.
- Thoroughly clean filters and surrounding area.
- Unscrew filters and remove them from the base assemblies. Discard both filters.

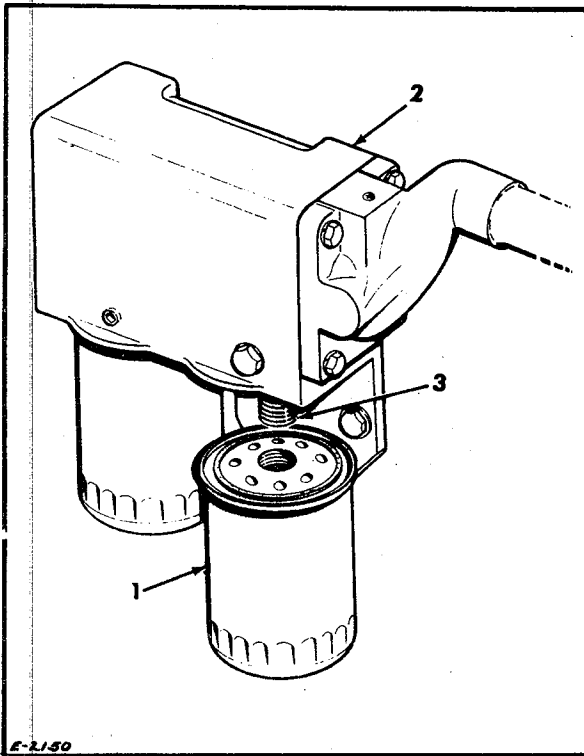

1. Lube oil filter
2. Oil cooler housing
3. Threaded insert

Figure 3. Full-Flow Oil Filters

- d. Apply light coat of lubricating oil to gasket of both replacement filters. Using hand pressure, screw each filter into position until gasket contacts surface of filter base assembly. Continue hand pressure and tighten each filter a minimum additional one half turn.

**CAUTION:** Do not use tools to tighten oil filters.

**CAUTION:** Always use Allis-Chalmers replacement filters.

- e. Install drain plug and fill oil pan with specified grade of lubricant to full mark on the oil level dipstick.
- f. Crank engine for 15 seconds but do not start. This is done to assure complete filling of the filters and to pump lubricant to engine components before it is started.
- g. Start engine and run for approximately 5 minutes.

- h. With engine running, check filters for leakage and make certain they are properly installed.
- i. Stop engine and allow several minutes for oil to drain back to the oil pan before checking level.
- j. Check oil level with dipstick. Add oil, if necessary, to raise level to FULL mark.

#### D. BYPASS OIL FILTER - OPTIONAL

##### 1. General

The remote mounted bypass (Fig 4) oil filter assist the full flow filter to remove impurities that cause sludge, acid, or varnish to form. The use of the bypass filter may permit the lubrication change period to be extended. The changed period should be established only after laboratory analysis of the oil has been made. (Refer to Topic 6.)

The filter must be mounted on a rigid support and as close as possible to the engine. The capacity of the filter is 6 quarts. This amount must be added to the full-flow filter and oil renewal quantity when both type filters and oil are renewed.

##### 2. Maintenance

The filter element must be changed at each lubrication change period. Refer to Figure 4 and replace the element as follows:

- a. Clean the filter cover (3) and surrounding area. Loosen the drain cock (11) in the bottom of the filter housing (10) and allow filter to drain. Remove the cover clamp (5) and lift the cover from the housing. Remove cover gasket (4) from lip of the housing.
- b. Remove the element (6) by unscrewing it (counterclockwise) from the outlet post (8) and lifting it from the filter housing.
- c. Clean the interior of housing and tighten drain cock.
- d. The replacement element kit includes a cover gasket. Install cover gasket in the lip of the filter housing.
- e. Insert the element and turn it clockwise until it is firmly seated on the outlet post.
- f. Fill engine oil pan with the specified

quantity of engine oil Refer to Topic 2, SPECIFICATIONS.

- g. Loosen vent plug (1) on top of filter cover. Start engine and operate at idle speed until oil appears at vent plug then tighten plug.
- h. Stop the engine and check oil level; add oil as necessary to raise oil to FULL mark on dipstick.
- i. Be sure filter warms up when the engine is started. If filter does not get hot, lines, fittings, or orifice may be plugged, or the lines to the filter may be connected backwards.
- j. Observe filter for leakage; correct any leaks.

**E. DRAINING AND FILLING THE LUBRICATING SYSTEM**

- 1. Before draining the system, operate the engine until the normal operating temperature is reached. Stop the engine.
- 2. Remove the drain plug from the oil pan and allow the oil to drain. Allow any foreign matter to settle, pour off the oil and examine the sediment, if any.
- 3. Reinstall the drain plug and fill the system with the specified grade and type of lubricant. FILL to the FULL mark on the dipstick.
- 4. Crank the engine, without starting, for 15 seconds. This will assure that the filters are filled and that lubricant has been pumped to the turbocharger and other engine components before the engine is started.
- 5. Start the engine and allow it to run for approximately 5 minutes.
- 6. Stop the engine, allow several minutes for the oil to drain back to the sump, and recheck the oil level. Add lubricant as required.
- 7. Inspect the lubricating system for leaks.

**F. ENGINE OIL COOLER**

The engine oil cooler (Fig 3 Item 2) is part of the cooler/filter assembly. Coolant is circulated through the cooling core tubes and engine lubricating oil is circulated around the tubes. The coolant absorbs heat from the oil, thereby controlling the oil temperature.

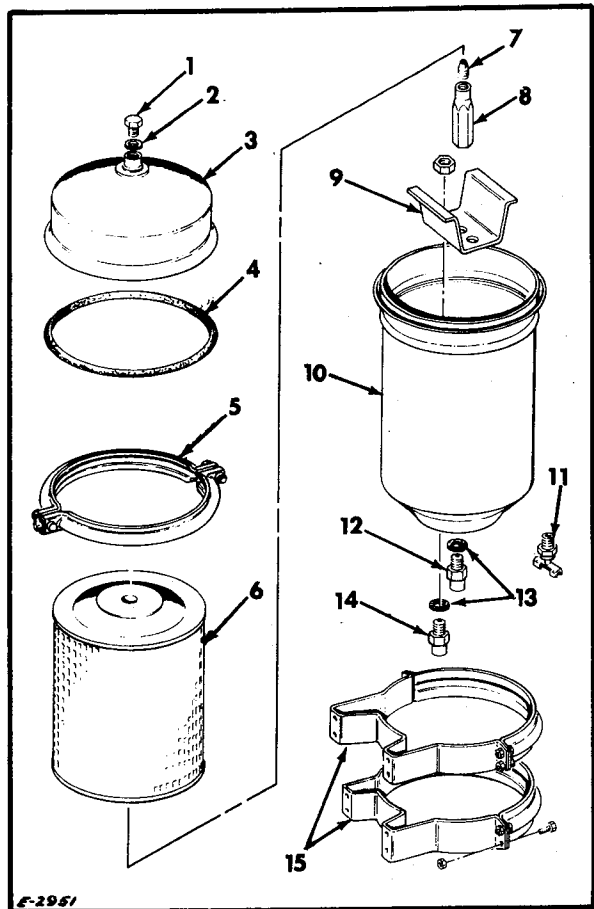

- |                         |                        |
|-------------------------|------------------------|
| 1. Vent plug            | 8. Outlet post         |
| 2. Sealing washer       | 9. Element support     |
| 3. Cover                | 10. Filter housing     |
| 4. Cover gasket         | 11. Drain cock         |
| 5. Cover retaining ring | 12. Inlet check valve  |
| 6. Element              | 13. Sealing washers    |
| 7. Plug-orifice         | 14. Outlet check valve |
|                         | 15. Mounting bands     |

Figure 4. Bypass Oil Filter

**CAUTION:** It is important that the oil cooler be kept clean and free of deposits in order to maintain proper cooling.

The cooling core consists of small corrosion resistant tubes which transfer the heat from the oil to the engine coolant. If the recommended maintenance and lubrication is not performed at the indicated interval, deposits may form in the oil cooler and restrict the flow of oil or coolant. Restriction of the flow of oil is usually indicated by a drop in

oil pressure and a rise in oil temperature. See Topic 11, COOLING SYSTEM, for complete removal, cleaning and installation procedures.

#### G. LUBRICATION SYSTEM MAINTENANCE

Proper maintenance of the lubrication system requires observance of the following:

##### 1. Lubricating oil

Lubricating oil must be of the best quality available and be of proper SAE weight for prevailing ambient temperature. (Refer to Topic 6.) Keep oil free of water and abrasives by proper handling and storage.

##### 2. Daily Check

Before each period of operation, check oil level in the oil pan. If necessary, add oil to bring level to FULL mark on the oil level gauge. Inspect engine for evidence of oil leaks and make necessary repairs.

##### 3. Cooling System Temperature

It is important the cooling system temperature be maintained at 180° (355 K) minimum, so lubricating oil will be hot enough for proper filtering. Low cooling system temperature will cause low oil temperature, and consequently, poor filtering of lubricating oil. This, in turn, will result in rapid wear of all moving parts.

##### 4. Engine Breather Tube

The purpose of the breather tube is to vent the inside of the engine to the atmosphere, thus preventing pressure buildup and removing harmful vapors from the crankcase, gear train, and valve compartment. If the tube becomes clogged, vapors are trapped within the engine, and pressure buildup will force oil past crankcase seals, dipstick, cylinder head cover gasket, etc.

At each 600 hours, remove breather tube from the cylinder head cover. Clean inside of tube with cleaning solvent, blow out with compressed air, and replace on engine.

##### 5. Oil Pressure Regulating Valve

The oil pressure regulating valve is located at the center of the right-hand side of the cylinder block just ahead of the front lube oil filter can.

The valve maintains stabilized oil pressure within the lubricating system. When

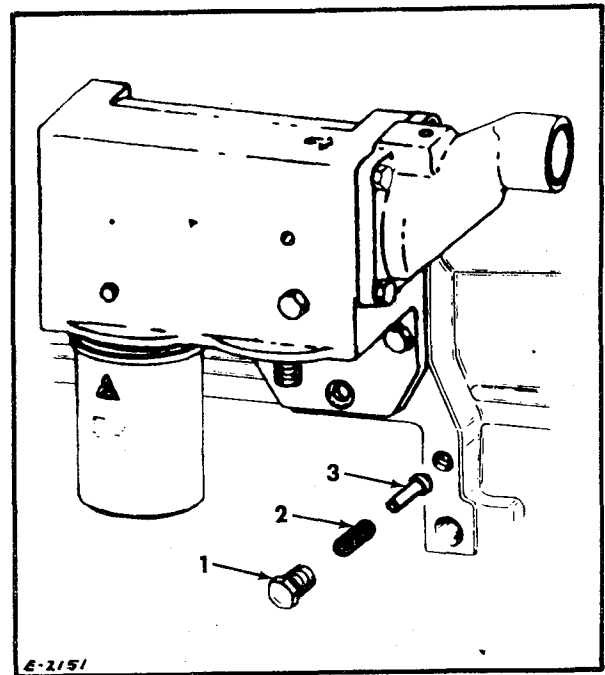

1. Adjusting screw
2. Spring
3. Piston

Figure 5. Oil Pressure Regulating Valve Details

the oil pressure exceeds the valve setting, the valve piston is forced off the valve seat and the oil is bypassed directly from the cylinder block to the oil pan. (Fig 5)

Keeping the lubrication free of sludge and foreign matter will help prevent a valve malfunction. If, for some reason, the valve sticks in the open position, a sharp drop in the engine oil pressure will occur. A sharp rise in oil pressure is indicative of a valve that does not open.

Remove, clean, and inspect the valve after every 5200 hours of normal operation. Proceed as follows:

- a. Thoroughly clean the area surrounding the pressure regulating valve.
- b. Noting the number of turns required for removal, remove the adjusting screw.

**NOTE:** The adjusting screw has a Lok-thread and therefore a gasket nylon pellet or jam nut is not required to prevent oil leakage or loosening.

c. Withdraw the spring and piston.

d. Wash the valve parts in a suitable cleaning solvent. Inspect the parts for wear and damage. Replace faulty or worn parts.

e. Thoroughly clean the valve bore in the cylinder block. Inspect the valve seat. Lubricate the valve piston with clean engine oil and reinstall the regula-

ting valve and spring. Turn the adjusting screw into the cylinder block the same number of turns required for removal.

f. Start the engine and allow it to reach a minimum operating temperature of 180<sup>o</sup> F. (355 K). Adjust the pressure regulator valve adjusting screw to obtain an oil pressure of 45 psi (310 kN/m<sup>2</sup>) at full load speed.



## TOPIC 14. ENGINE ELECTRICAL SYSTEM

### A. GENERAL

A conventional electrical system includes the starter, alternator, voltage regulator, and batteries. Current is supplied by the wet cell type storage batteries. The system has a negative ground.

**NOTE:** The starter, battery charging alternator, and regulator are supplied by either the OEM manufacturer or Allis-Chalmers. Ascertain the supplier of the equipment. The data in this topic is for the electrical equipment assembled to the engine by Allis-Chalmers.

The basic units of the charging circuit are the batteries, alternator, and regulator. The batteries are the storage plant for electrical energy and must be kept fully charged while using a minimum amount of water. Electrical energy, drained from the batteries, is replaced by the alternator. Too much power output will usually burn out the alternator or damage the batteries. To prevent this a voltage regulator is connected into the circuit.

### B. WARRANTY AND ADJUSTMENT

Manufacturers of the battery, starter, alternator, and regulator, are responsible for this equipment during the warranty period. Any claim for replacement or repair of these items must be presented to the manufacturer, not to Allis-Chalmers. Suppliers of such equipment are represented by distributors or dealers in nearly all cities who are authorized to make reasonable adjustments or replacements. Always provide model and serial number of the engine and date it was delivered.

### C. BATTERY

1. If liquid level is low, add distilled water to bring level of each cell up to bottom of filler hole. DO NOT OVERFILL.
2. Be sure filler plugs are tight and plug vents are open.

**CAUTION:** Never fill battery after operation in below freezing weather; water will not mix with acid and may freeze. Always fill batteries before putting engine into service.

3. Periodically check external condition of batteries and cables. Keep batteries clean and secured. If batteries are dirty, clean with a soda solution and brush; filler

plugs must be tight to prevent solution from entering cells. After foaming stops, flush with clean water.

**CAUTION:** When any work is performed on the electrical charging system, disconnect the battery ground cable to prevent short circuits.

4. After cleaning, apply a thin coat of vaseline to posts and cable terminals.
5. In below freezing temperatures, keep batteries in a fully charged condition.

**CAUTION:** When charging battery it is very important that the polarities of the battery and charger agree; connect positive to positive and negative to negative. When using booster batteries observe the same polarity rule.

6. Check charge condition or specific gravity with a hydrometer with electrolyte temperature at 80°F (300 K).

|                      |                       |
|----------------------|-----------------------|
| 1.110 to 1.135 ...   | Completely discharged |
| 1.170 to 1.200 ..... | 1/4 charged           |
| 1.205 to 1.230 ..... | 1/2 charged           |
| 1.235 to 1.260 ..... | 3/4 charged           |
| 1.265 to 1.290 ..... | Fully charged         |

Specific gravity readings without correction for temperature are practically meaningless. For each 10°F (5.55 K) that the temperature of the electrolyte is above 80°F (300 K) add 4 points to the hydrometer reading, and for each 10°F (5.55 K) that the temperature is below 80°F (300 K) subtract 4 points to obtain true specific gravity.

Example:

|   |       |
|---|-------|
| Hydrometer reading .....                  | 1.250 |
| Electrolyte temperature ... 20°F (267 K)  |       |
| Degrees below 80°F (300 K) .. 60°F (33 K) |       |
| Four (4) points each 10°F (5.55 K) ..     | 24    |

|                          |       |
|--------------------------|-------|
| Hydrometer reading       | 1.250 |
| No. of points subtracted | 24    |
| True specific gravity    | 1.226 |

**CAUTION:** In cold weather batteries with a specific gravity of 1.110 will freeze at 18°F (265 K); batteries with a specific gravity of 1.220 will freeze at -31°F (238 K).

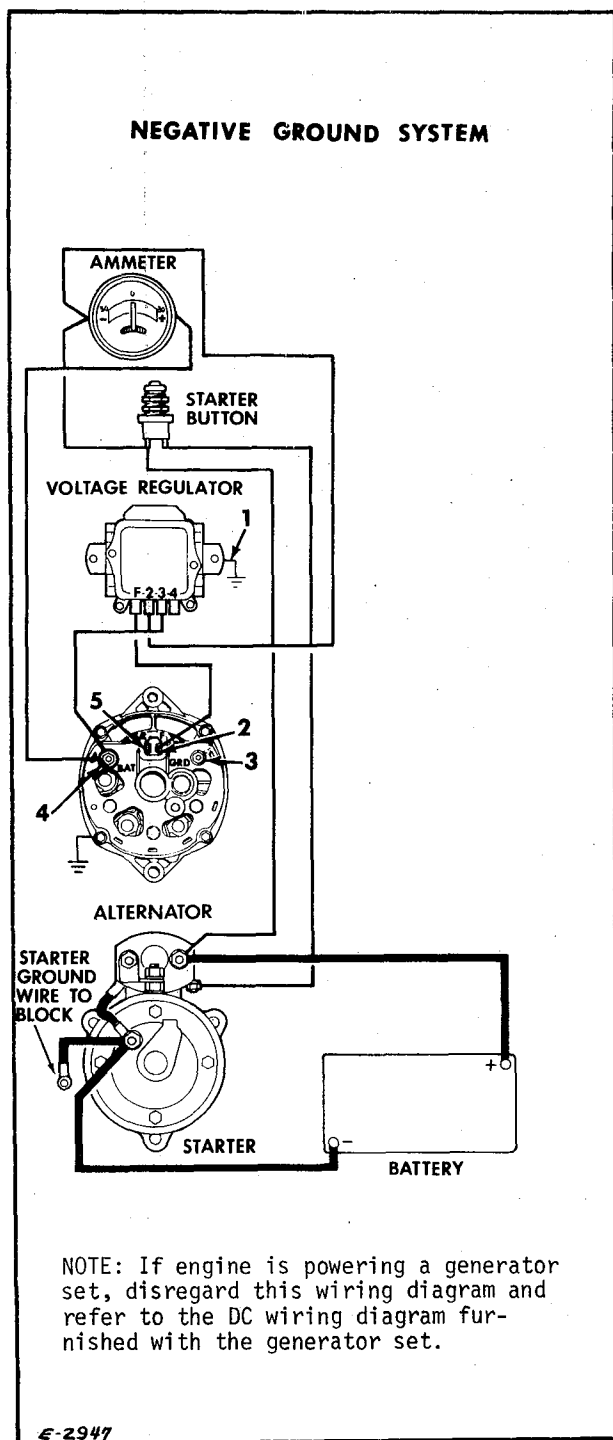

1. Ground wire
2. Field terminal (F)
3. Ground terminal (GRD)
4. Battery terminal (BAT)
5. Relay terminal

Figure 1. Alternator and Regulator Wiring Diagram

#### D. ELECTRIC STARTING MOTOR

The electric starting motors are heavy duty 12-volt, overrunning clutch type. The solenoid switch for closing the starting circuit is an integral part of the starter.

A shift lever in the drive housing is connected by linkage to the solenoid switch so that operation of the solenoid not only closes the circuit between battery and starting motor, it also shifts the drive pinion into mesh. The starting motor electrically cranks the engine when the starting switch closes the circuit between it and the storage battery. During starting, the action of the starting motor should be noted. The starting motor should take hold promptly and spin the engine. After the engine starts, and the starting motor switch is opened, the starting motor should stop operating.

**CAUTION:** Do not operate cranking motor continuously for more than 30 seconds without pausing to allow it to cool for at least 2 minutes. Failure to observe this rule can result in overheating and failure of the motor.

#### 2. Removal and Installation

- a. Disconnect battery ground cable at battery.
- b. Disconnect cables and lead wires from the starter.
- c. Remove capscrews and lockwashers attaching the starter to the flywheel housing and remove starter and starter adaptor.
- d. Install starter by a direct reversal of removal procedure. Connect cables and wires to starter.

#### 3. Maintenance

- a. During startup, note starting motor action. The starter pinion gear should mesh promptly with the flywheel ring gear and spin the engine. After engine starts and motor switch opens, the starting motor should stop operating.
- b. If starting motor cranks engine slowly or not at all, check the equipment. Failure to crank is normally caused by low battery charge, defective battery cables, poor connections in starting motor to battery circuit, defective starting motor, low temperatures, or various conditions in the engine.
- c. Inspection checks include a periodic

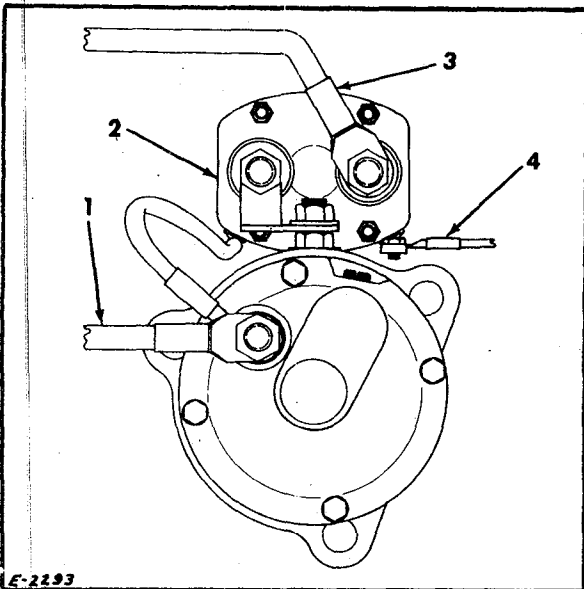

1. Cable (ground)
2. Starter solenoid
3. Cable ( to positive post of battery)
4. To starter switch

Figure 2. Starter

investigation of battery condition, battery cables and connections, starting motor, solenoid switch, commutator, brushes, lead connections, and mounting.

- d. Starter motor bearings are lubricated only when unit is disassembled for inspection or repair.
- e. The brushes must be making good contact with the commutator (80 ounces (2.26 kgs) of spring tension) and must not be worn shorter than 5/16" (7.93 mm) long. Their original length is 1/2" (12.7 mm).
- f. A dirty commutator should be cleaned with #00 sandpaper.

**CAUTION:** Do not clean commutator with emery cloth. Emery is a conductor and can cause electrical shorts.

## E. ALTERNATOR

### 1. General

The negative ground alternators are designed and constructed to provide extra long periods of reliable service. Two brushes are used to carry current through two slip rings to the field coil which is mounted on the rotor. The brushes and

brush springs are located in a brush holder secured to the end frame at the rear of the alternator. To gain access to the brush holder, the end frame must be separated from the rotor and drive frame at the front of the alternator.

The rotor is mounted on a ball bearing at the drive end and a roller bearing at the slip ring and each bearing has a grease supply which eliminates the need for periodic lubrication.

Six rectifier diodes mounted in the slip ring end frame change the AC to DC and this voltage appears at the BAT terminal on the alternator.

**CAUTION:** The ground polarity of the regulator and the ground polarity of the battery and alternator must be the same before making any connections. DO NOT attempt to polarize the alternator. DO NOT ground the alternator output terminal.

The function of the regulator in the charging circuit is to limit the alternator voltage to a pre-set value by controlling the alternator field current. See Topic 2, titled, Specifications, for ratings of alternators.

**CAUTION:** The regulator and alternator should never be operated without a battery in the circuit. Do not short between regulator terminals and ground.

### 2. Alternator Removal

- a. Remove capscrews and lockwasher attaching the alternator to the alternator adjusting brace. Remove the drive belts.
- b. Disconnect battery ground cable, identify and disconnect the alternator lead wires.
- c. Remove capscrews and lockwashers attaching the alternator to the mounting bracket and remove the alternator.

### 3. Maintenance

- a. Check the drive belt for alignment, tension, and wear. Alternator belt tension is a bit more critical than with a DC generator. Check for loose mounting bolts or a loose drive pulley.

- b. Inspect the terminals for corrosion and loose connections. Check wiring for damaged insulation.

**NOTE:** A inspection of the brushes and slip rings can be made by separating the end frame from the drive end frame.

- c. If the surface of the slip rings is smooth but covered with a carbon-oil-dirt mixture, clean with 400 grain or finer polishing cloth.

**CAUTION:** Flat spots may result if slip rings are cleaned without spinning the rotor, and the flat spots, in turn, may cause electrical brush noise.

- d. If slip rings are rough or out of round the alternator must be disassembled so the slip rings can be trued in a lathe to a .002" (0.05 mm) maximum indicator reading. Remove only enough material to make rings smooth and round. Finish with 400 grain or finer polishing cloth and blow all dust away.
- e. The bearing in the slip ring end frame should be replaced if the grease in the bearing is exhausted. No attempt should be made to relubricate or reuse it. If the bearing in the drive end frame is satisfactory, remove bearing retainer plate and press it from the end plate. Fill bearing one-quarter full with Delco-Remy lubricant No. 1960373. Assemble bearings in alternator in reverse order of disassembly.

**CAUTION:** Do not overfill reservoirs because this will cause the bearings to overheat.

#### 4. Alternator Installation

- a. Do not polarize the alternator.
- b. Install in the reverse order of removal.
- c. Adjust alternator and fan drive belts. Refer to following Paragraph H. To prevent accidental grounding a lead and damaging the diodes when removing and installing an alternator or regulator, always remove the ground cable from the battery.

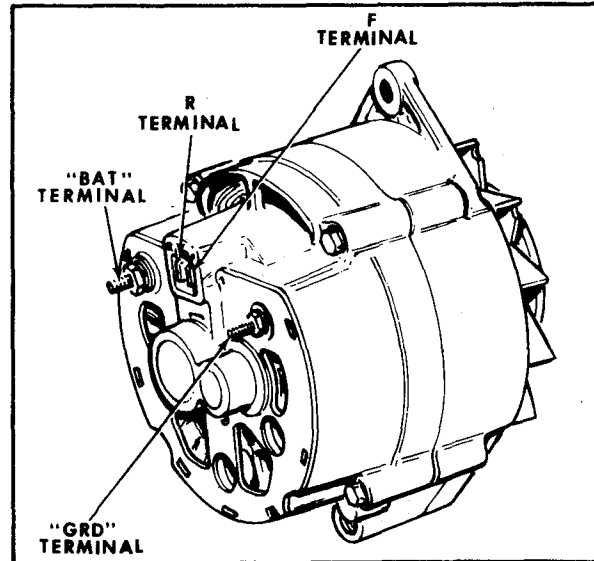

Figure 3. Alternator

#### F. VOLTAGE REGULATOR

##### 1. General

The voltage regulator is a two unit regulator consisting of a voltage regulator unit and field relay unit. The voltage regulator unit operates to limit alternator voltage to a pre-set value, whereas the field relay unit connects the alternator field winding and regulator winding directly to the battery.

The two unit regulator has 4 slip connection type terminals. A projection on the connector body serves to latch the assembly together and prevent disconnections due to vibration. The assembly can be disconnected by lifting slightly on the latch. (Fig 4 Item 5).

**CAUTION:** Polarities of the regulator, alternator, and battery must be the same. Instant damage will result if polarities are mismatched. Do not short across or ground regulator terminals. Do not operate without a battery.

##### 2. Voltage Regulator Removal

- a. Mark regulator lead wires for subsequent identification. Disconnect lead wires.
- b. Remove attaching capscrews nuts, and lockwashers and remove regulator.
- c. Install voltage regulator in reverse order of removal.

##### 3. Service

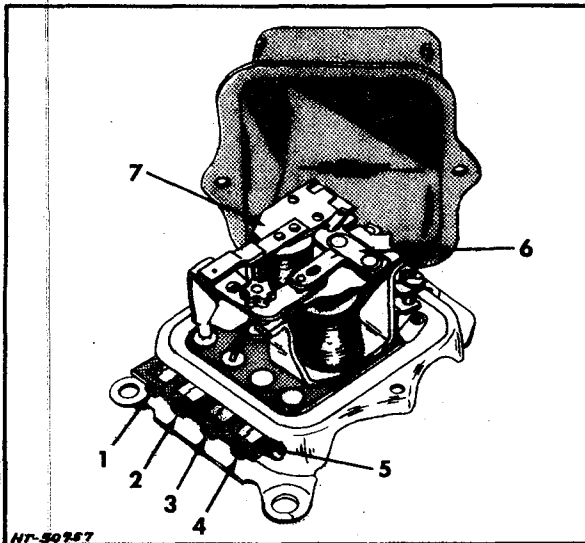

- |                   |                           |
|-------------------|---------------------------|
| 1. F terminal     | 5. Latch                  |
| 2. No. 2 terminal | 6. Voltage regulator unit |
| 3. No. 3 terminal | 7. Field relay unit       |
| 4. No. 4 terminal |                           |

Figure 4. Two Unit Voltage Regulator

Do not clean voltage regulator contacts unless performance indicates cleaning is necessary. A sooty or discolored appearance of contacts is normal after a relatively short period of operation and is not an indication that cleaning is necessary. However, if the voltage fluctuates, as evidenced by an unsteady voltmeter indication, contacts may have excessive resistance or be sticking and therefore, should be cleaned.

**CAUTION:** Before cleaning, make sure fluctuating voltage is not caused by loose connections or high resistance elsewhere in the system.

Contacts of the voltage regulator unit are made of soft material and must not be cleaned with a file. A strip of No. 400 silicon carbide paper, or equivalent, folded over and then pulled back and forth between the contacts is recommended as a satisfactory method of cleaning.

After cleaning, wash contacts with trichloroethane or alcohol to remove any residue. If voltage control has not improved, repeat cleaning and washing process.

Clean field relay contacts with a thin, fine-cut, flat file. Never use emery cloth or sandpaper. Remove only sufficient material to clean.

## G. ALTERNATOR DRIVE BELT ADJUSTMENT

1. Replace belts if they are damaged, badly worn, or soaked with oil and grease. Even though only one belt may need replacement because of damage or excessive wear, it is imperative that both belts be replaced to obtain satisfactory belt life.
2. Check tension of drive belts using a Borroughs Tension Gauge (BT-33-74) or equivalent. New drive belts are installed with a tension of 125 pounds (57 kg). Belts must be retightened whenever tension drops to 85 pounds (38 kg). Always retighten old belts and pulleys to 105 pounds (48 kg).
3. To obtain proper belt tension, loosen the alternator adjusting brace capscrew and mounting screw and move alternator in or out as required.

4. Retighten the capscrew

## H. AIR HEATER

If the engine does not start with the aid of the intake air heater, it is advisable to stop cranking the engine and inspect the heater circuit for the following causes of failure.

### 1. Open Electrical Circuit

Check all electrical connections for the operation of the heater and make certain the connections are tight. Make sure all cables are in good condition; wrap any frayed spots in the insulation with friction tape or replace cables.

### 2. Heating Element Broken or Burned Out

On a turbocharged engine, remove the turbocharger to intake manifold crossover pipe. Visually inspect element for a broken or burned out element wire; press heater switch and observe if the element becomes hot.

### 3. Inoperative Heater Switch

If the malfunction of the air heater was not due to a broken or burned out heating element, check heater switch with a jumper cable to see if it is inoperative. Replace if necessary.

### 4. Solenoid Switch

When the heater switch is closed, the solenoid switch is energized, and it closes the circuit to the heater element. This solenoid switch consists basically of contacts and a winding around a hollow cylinder containing a moveable plunger. When the winding is energized, the plunger is pulled

inward closing the contacts to the heater element. To determine if contacts for the heater element are closing, disconnect the lead to the heater, connect a voltmeter between this terminal and ground. Press the

heater switch, battery voltage should be read on the voltmeter. The solenoid switch is non-adjustable and non-repairable. Whenever it becomes inoperable, it must be replaced with a new solenoid switch.

## TOPIC 15. VALVE ADJUSTMENT AND CYLINDER HEAD

### A. VALVE LASH ADJUSTMENT

Correct clearance (valve lash) between end of intake valve stem, exhaust valve stem, and related rocker arms, is very important in diesel engine performance because of high compression developed within the cylinders. Insufficient valve lash will cause loss of compression, misfiring, and eventually lead to burning of valves and valve seats. Excessive valve lash will result in faulty engine operation, valve lifter noise, and cause rapid wear on the valve operating mechanism. With engine at normal operating temperature of 160°F (344 K) minimum, specified valve lash for both intake and exhaust valves is 0.015" (0.38 mm). After any mechanical work has been done that may have disturbed the valve lash adjustment, set valves "cold" at 0.018" (0.45 mm) clearance so engine can be run and allowed to warm to normal operating temperature. After engine has warmed up to normal operating temperature, check valve lash again for proper clearance.

**CAUTION:** After any mechanical work has been done that may have disturbed the valve lash adjustment, make certain the rocker arm adjusting screws are turned upward (counterclockwise) high enough to prevent rocker arms and push rods from opening too far. If rocker arms and push rods open too far, the pistons will strike the valves when the engine is cranked.

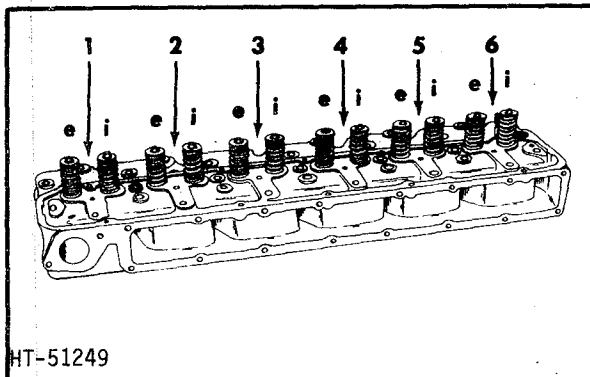

- |  |  |
|--|--|
| 1. No. 1 cylinder<br>e. Exhaust valve<br>i. Intake valve | 4. No. 4 cylinder<br>e. Exhaust valve<br>i. Intake valve |
| 2. No. 2 cylinder<br>e. Exhaust valve<br>i. Intake valve | 5. No. 5 cylinder<br>e. Exhaust valve<br>i. Intake valve |
| 3. No. 3 cylinder<br>e. Exhaust valve<br>i. Intake valve | 6. No. 6 cylinder<br>e. Exhaust valve<br>i. Intake valve |

Figure 1. Valve Locations

Valve lash must be adjusted when the piston is near top dead center on its compression stroke and intake and exhaust valves are closed. Number 1 and Number 6 pistons move up and down in their respective cylinders simultaneously. When one piston is on its compression stroke, the other is on its exhaust stroke, and vice versa. Observe valves for Number 6 cylinder; when the exhaust valve is almost closed and the intake valve starts to open, Number 6 piston is near top dead center on its exhaust stroke and Number 1 piston is in the same position on its compression stroke. At this point, both valves for Number 1 cylinder are closed and valve lash can be adjusted. Engine firing order is 1-5-3-6-2-4, and if this sequence is followed, the lash for all valves can be checked and adjusted in 2 complete revolutions of the crankshaft. Check valve clearance periodically. When adjustment is necessary, proceed as follows to obtain specified clearance:

1. Run engine until operating temperature of 160°F (344 K) minimum is reached. Stop the engine.
2. Thoroughly clean cylinder head cover and surrounding area.
3. Remove breather tube, capscrews, washers, and cylinder head cover.

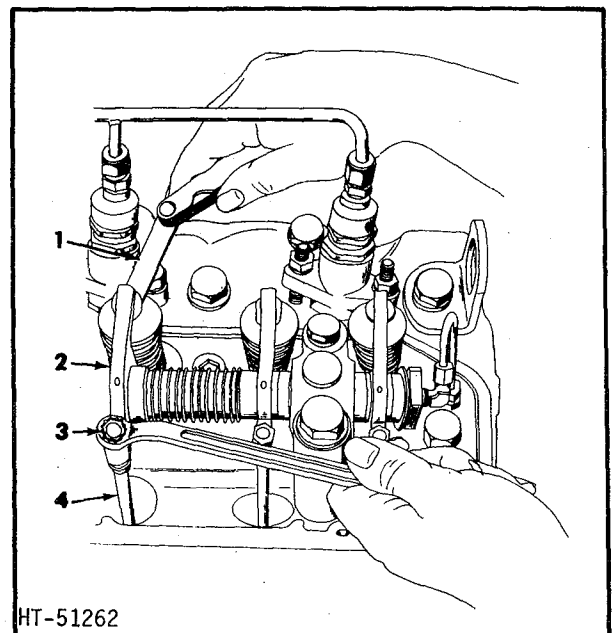

- |                 |                     |
|-----------------|---------------------|
| 1. Feeler gauge | 3. Adjusting screw* |
| 2. Rocker arm   | 4. Push rod         |
- \* Adjusting screw must be replaced when less than 36 lb-in. (4 Nm) driving torque is required to turn it.

Figure 2. Adjusting Valve Lash

4. Crank engine until exhaust valve for Number 6 cylinder is almost closed and intake valve starts to open, then check and adjust intake and exhaust valve lash for Number 1 cylinder.
5. Use a 0.015" (0.38 mm) feeler gauge and check clearance between valve stems and rocker arms. Gauge should pass between rocker arm and corresponding valve stem with a slight drag when valve lash is properly adjusted.
6. Adjust each valve by turning adjusting screw clockwise to decrease clearance or counterclockwise to increase clearance as necessary.
7. Crank engine until Number 2 cylinder exhaust valve is almost closed and intake valve starts to open, then adjust lash for intake and exhaust valves for Number 5 cylinder, following procedure in preceding Steps 5 and 6.
8. Crank engine until Number 4 cylinder exhaust valve is almost closed and intake valve starts to open, then adjust lash for intake and exhaust valves for Number 3 cylinder, following procedure in preceding Steps 5 and 6.
9. Crank engine until Number 1 cylinder exhaust valve is almost closed and intake valve starts to open, then adjust lash for intake and exhaust valves for Number 6 cylinder, following procedure in preceding Steps 5 and 6.
10. Crank engine until Number 5 cylinder exhaust valve is almost closed and intake valve starts to open, then adjust lash for intake and exhaust valves for Number 2 cylinder, following procedure in preceding Steps 5 and 6.
11. Crank engine until Number 3 cylinder exhaust valve is almost closed and intake valve starts to open, then adjust lash for intake and exhaust valves for Number 4 cylinder, following procedure in preceding Steps 5 and 6.

#### B. TORQUING CYLINDER HEAD CAPSCREWS

If the cylinder head is removed for any reason, such as repair, overhaul, etc., the cylinder head capscrews must be tightened evenly and in the sequence illustrated in Figure 3. A new cylinder head gasket must be used when installing the cylinder head. Make certain the gasket is installed with the indicated side down. Install cylinder head as follows:

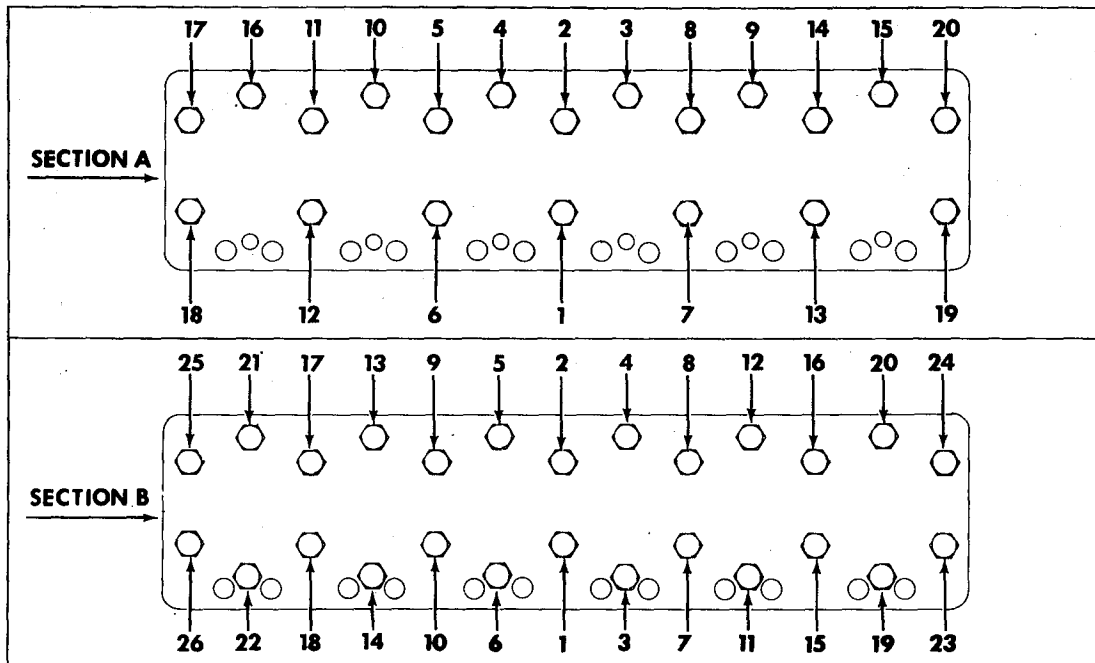

HT-50775

Figure 3. Cylinder Head Capscrew Locations and Torquing Sequence



1. Thoroughly clean top deck of cylinder block and under-side of cylinder head.
2. Check for specified 0.002" to 0.005" (0.05 to 0.13 mm) cylinder sleeve protrusion above top deck of block. Correct, if necessary, by reconditioning sleeve seat in block with recommended tool and installing sleeve shims under sleeve flange to obtain 0.002" to 0.005" (0.05 to 0.13 mm) protrusion.
3. Install new gasket on cylinder block with indicated side down as stamped on gasket. Follow instructions packaged with service cylinder head gasket. Do not use sealer or gasket dope. The gasket as supplied has been pre-coated with phenolic sealer and an anti-stick compound.
4. Install the fire rings on each cylinder sleeve being certain no overlapping of fire rings and gasket occurs.
5. Install cylinder head. Lubricate threads and underhead area of the 20 short cylinder head capscrews with light coat of engine lubricating oil and install in cylinder head. Tighten capscrews to 90 to 110 lb-ft (122 to 150 Nm) torque following sequence depicted in Figure 3, Section A.

**CAUTION:** Torque figures in this and following steps are based on engine oil lubricated threads. To prevent overstressing of capscrews, do not use extreme pressure lubricants of any kind.

6. Lubricate threads and underhead area of the 6 long capscrews with light coat of engine lubricating oil. Install rocker arm shaft and bracket assembly. Starting at center of head and working alternately toward each end, tighten capscrews to 90 to 100 lb-ft (122 to 136 Nm) torque.
7. Tighten all 26 capscrews to 165 lb-ft (224 Nm) torque following sequence depicted in Figure 3, Section B.

**NOTE:** A cylinder head wrench equivalent to "Snap-On" S-8684 is required for tightening capscrews under the rocker arm shaft.

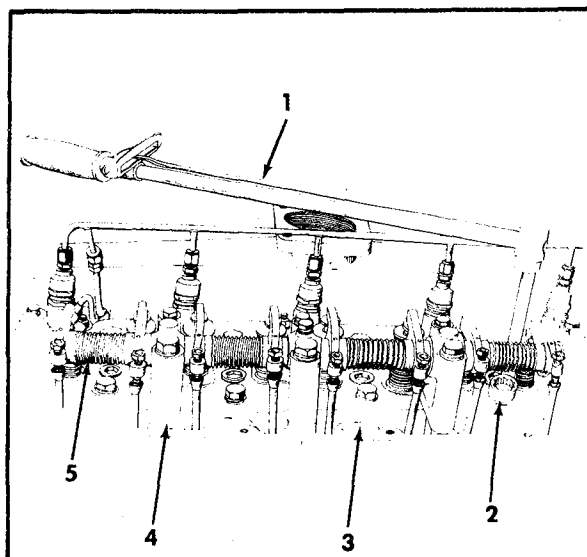

1. Torque wrench
2. Cylinder head wrench
3. Cylinder head
4. Rocker arm shaft bracket
5. Rocker arm shaft

Figure 4. Torquing Cylinder Head Capscrews

8. Retighten all 26 capscrews to 165 lb-ft (224 Nm) torque following sequence depicted in Figure 3, Section B.
9. Lubricate threads of six 3/8" capscrews with light coat of engine lubricating oil. Install capscrews in rocker arm brackets and tighten to 28 to 33 lb-ft (38 to 45 Nm) torque. Adjust all intake and exhaust valves cold to a clearance of 0.018" (0.45 mm). Run engine for approximately 1 hour, preferably under load, with minimum water temperature of 160°F (344 K).
10. Retighten all 26 capscrews to 165 lb-ft (224 Nm) torque, following sequence depicted in Figure 3, Section B. If cap screw does not move when 165 lb-ft (224 Nm) torque is reached, back it off slightly by loosening, then retighten to specified torque. This is important in eliminating possible false torque readings due to temporary thread seizure.
11. Adjust the valve lash clearance settings to 0.015" (0.38 mm) hot (refer to preceding Paragraph A).

7

## TOPIC 16. INTAKE AND EXHAUST SYSTEMS

### A. GENERAL

The intake and exhaust systems consist of those components that convey filtered air to engine cylinders and exhaust gases to the atmosphere. The intake system consists of intake valves, intake manifold, and air cleaner. The exhaust system consists of exhaust valves, exhaust manifold, muffler, and exhaust piping extensions. The compressor side of the turbocharger is part of the intake system and the turbine side is part of the exhaust system.

It is important that an ample supply of fresh clean air be provided to the combustion chambers. Insufficient air will limit amount of fuel the engine can burn and lead to loss of power, excessive exhaust smoke, high fuel consumption, and eventually to engine failure.

In warm weather, sufficient heat is generated by compression of air within the cylinders to ignite the fuel and start the engine within a very short cranking period. However, in cold weather the "drag" caused by cold oil between pistons and cylinder walls and in the bearings, reduces cranking speed of the engine. A large part of the heat generated by compression of air is absorbed by the cold pistons and cylinder walls. This heat loss and reduced cranking speed may lower temperature of air in the cylinders to a point too low to ignite the fuel. In this case engine starting may be assisted by use of a cold weather starting aid.

**CAUTION:** Muffler installations or exhaust pipe extensions from the turbocharger exhaust elbow must be adequately supported and flexibly connected to eliminate possibility of strain on the turbocharger outlet.

Total restriction of the entire exhaust system of a turbocharged engine at the exhaust outlet with engine under full speed, full load conditions, must not exceed 2" (51 mm) (6754 N/m<sup>2</sup>) of mercury back-pressure. If there is any question as to whether or not the engine has excessive exhaust back-pressure, check with a mercury manometer as depicted in Figure 1.

On turbocharged engines, the manometer is connected to the exhaust elbow. (See Figure 1). Drill and tap a 0.25" (6.35 mm) pipe threaded hole in the side of the exhaust elbow. To connect manometer to exhaust elbow, screw a 0.25" x 0.125" (6.35 x 3.175 mm) reducer bushing into the threaded hole. Fitting must be flush with inside and perpendicular to elbow to avoid false readings. Fasten about 3 feet (914 mm) of 0.25" (6.35 mm) OD copper tubing to the fitting. From the other end of the copper tubing connect length of rubber tubing to one side of the manometer.

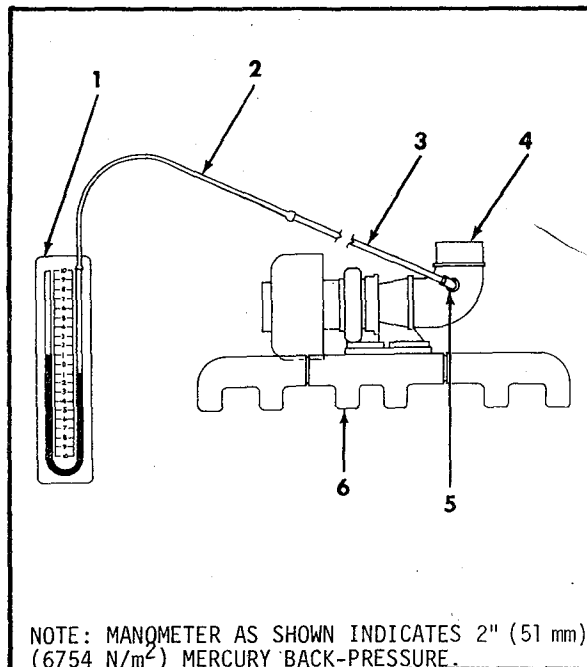

1. U-tube manometer
2. Rubber tubing
3. Copper tubing
4. Exhaust elbow
5. Location of fitting
6. Exhaust manifold
7. Turbocharger

Figure 1. Checking Exhaust Back-Pressure

It should be noted in the illustration (Fig 1) that the manometer scale is graduated in inches both above and below the 0 mark, and each inch is divided into tenths. When manometer is set up for use, sufficient mercury must be put in the U-shaped tube so height in both columns aligns with 0 line on the scale.

Take the exhaust back-pressure readings when engine is developing its maximum horsepower and rpm. When reading manometer, add height of liquid in both columns to obtain final figure. For example, if liquid is 1" (25 mm) (3377 N/m<sup>2</sup>) high in left column and 1" (25 mm) (3377 N/m<sup>2</sup>) low in right column, the manometer indicates 2" (951 mm) (6754 N/m<sup>2</sup>) of mercury back-pressure.

NOTE: If mercury is 1" (25 mm) (3377 N/m<sup>2</sup>) high in right column and 1" (25 mm) (3377 N/m<sup>2</sup>) low in left column, the manometer indicates 2" (51 mm) (6754 N/m<sup>2</sup>) of mercury vacuum, rather than pressure. A 1" (25 mm) (3377 N/m<sup>2</sup>) mercury indication is equivalent to 0.491 psi (3.39 kN/m<sup>2</sup>)

NOTE (Cont): 2" (51 mm) (6754 N/m<sup>2</sup>) of mercury is equal to twice 0.491 (3.39 kN/m<sup>2</sup>) or 0.982 psi (6.78 kN/m<sup>2</sup>). If a manometer is not available, an accurate pressure gauge can be used.

Excessive back-pressure will result in poor engine performance and shortened engine life. Measurement of exhaust pressure will indicate whether or not capacity of exhaust system is adequate. If back-pressure reading is higher than the specified figure, one or more of the following factors is the cause:

1. Sharp right angles or excessive bends in exhaust piping. All angles and bends must be gentle sweeping curves. Piping should have as few angles/bends as possible.
2. Exhaust piping diameter too small. Pipe size must never be less than diameter of exhaust outlet opening. As piping length increases, so should the diameter.
3. Foreign material causing restrictions in muffler or piping.

4. Inadequate muffler capacity.

#### B. MANIFOLD MAINTENANCE

1. Use new gaskets when reinstalling manifolds.
2. Periodically check all manifold mounting capscrews for tightness after engine is hot. Tighten manifold mounting capscrews to specified torque, starting at the center and working alternately toward each end. Tighten intake manifold mounting capscrews to 20 lb-ft (27 Nm) torque and exhaust manifold mounting capscrews to 68-73 lb-ft (92-99 Nm).
3. At time of overhaul, check manifold for carbon deposits. Clean and remove obstructions found within the manifold.
4. If manifold is cracked, repair or replace as necessary.
5. If mounting surfaces of one section are warped and will not seal, it must be replaced or remachined. If material is machined from one section, a like amount must be removed from the other two sections.

## TOPIC 17. AIR CLEANER

### A. GENERAL

The purpose of the air cleaner is to remove dust and other foreign material from air used by the engine. Engine life depends largely on efficiency of the air cleaner. Rapid wear on cylinder sleeves, pistons, and rings will result if it is not kept in good condition and properly serviced.

Regardless of the type of air cleaner applied to the engine, the frequency of the element renewal interval is dependent upon the amount of foreign material in the air surrounding the working location of the engine.

Allis-Chalmers supplied air cleaners (Fig 1, 7 and 8) are equipped with a filter service indicator. Service the filter when so indicated. However, if a service indicator is not utilized, a cartridge renewal period should be determined by daily inspection of the air cleaner under actual operating conditions, until the period can be established.

The maximum allowable restriction (vacuum) in the air cleaner is 25 inches of water (6221 N/m<sup>2</sup>) at load full speed.

Inspect air cleaner body periodically for dents, cracks, etc. Also check for damaged gaskets and hoses, loose hose clamps, and for leaks that allow air to enter engine without first passing through the filter element. Correct any such condition found by immediate repair or replacement of faulty parts.

NOTE: Always refer to instruction on air cleaner.

### B. SERVICE

#### 1. Donaldson Air Cleaner - Single Element Type

The Donaldson single element type (Fig 1) is mounted horizontally with the stack cap in vertical position. Inspect dust cup daily or prior to operating the engine. Do not allow dust level to build up to less than 1.000" (25.4 mm) from slot in dust cup baffle. Each time air cleaner is serviced, inspect stack cap and clean as required.

When servicing the air cleaner, reduce engine down time to a minimum by replacing a dirty filter element with a new element or one that has been cleaned. Service the dirty element later, using procedures detailed below in Optional Service Methods.

#### a. Air Cleaner Service - Single Element Type

- (1) Clean baffle and dust cup (Fig 2) as follows:
  - (a) Clean exterior of air cleaner and surrounding area.
  - (b) Loosen clamp assembly and remove dust cup.
  - (c) Loosen wing nut and remove baffle from dust cup.
  - (d) Empty dirt from cup. Clean cup and baffle.
- (e) Remove foreign material from around filter element.
- (f) Assemble baffle to dust cup. Tighten wing nut.

NOTE: Empty and clean dust cup and baffle daily or more often if required. Dust level must not be allowed to build up to less than 1.000" (25.4 mm) from slot in dust cup.

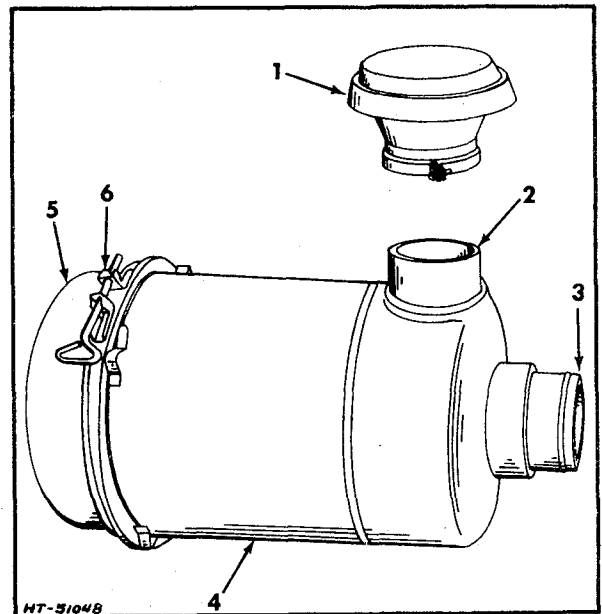

- |               |                   |
|---------------|-------------------|
| 1. Stack cap  | 4. Body           |
| 2. Air inlet  | 5. Dust cup       |
| 3. Air outlet | 6. Clamp assembly |

Figure 1. Donaldson - Single Element Type Air Cleaner

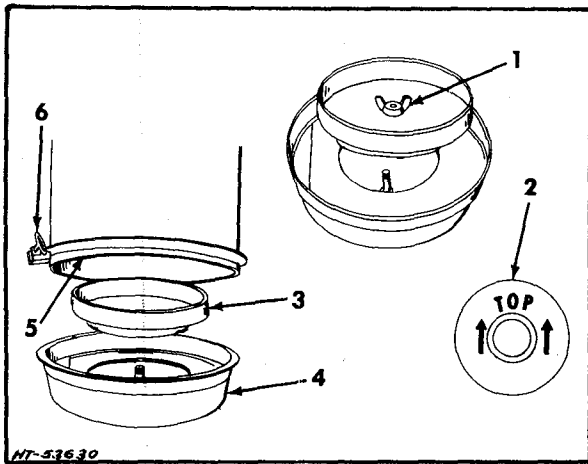

- 1. Wing nut
- 2. Dust cup bottom
- 3. Baffle
- 4. Dust cup
- 5. Cup gasket
- 6. Clamp assembly

Figure 2. Baffle and Dust Cup Details

- (g) Position dust cup on air cleaner body and tighten the clamp assembly securely.

**CAUTION:** Bottom of dust cup is marked with arrows and the word TOP. Air cleaner is mounted in horizontal position. Be sure dust cup arrows point up (Fig 2). Do not use oil in dust cup.

- (2) Replace filter element as follows:
  - (a) Clean or replace filter element when red signal covers exposed section of window on air filter service indicator.
  - (b) Remove dust cup.
  - (c) Remove wing screw and gasket washer. Remove filter element (Fig 3).
  - (d) Inspect element gasket for damage.
  - (e) Install a new or clean element. Inspect cup gasket (if applicable) and replace if it is damaged.
  - (f) Install dust cup on air cleaner body.

**CAUTION:** Air cleaner is mounted in horizontal position. Be sure dust cup arrows point up. (See Fig 2.) Do not use oil in dust cup. Always refer to manufacturers instruction on air cleaner.

- (g) Reset service indicator by pressing reset button on top of indicator.

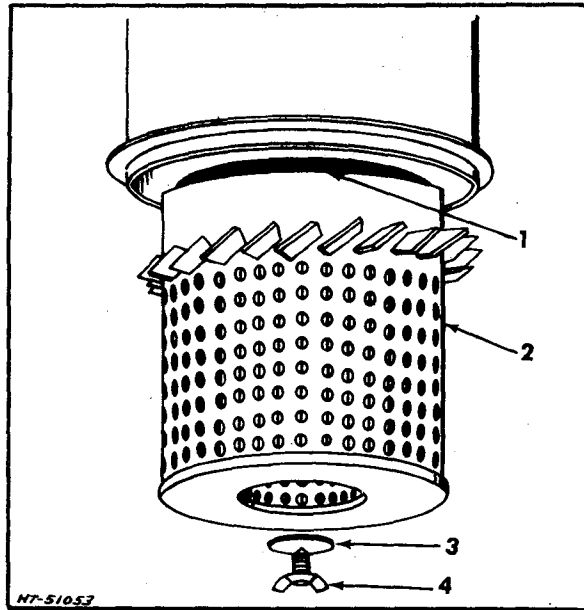

- 1. Element gasket
- 2. Filter element
- 3. Gasket washer
- 4. Wing screw

Figure 3. Removing Filter Element

(3) Optional Service Methods

The filter element can be either dry cleaned or washed as detailed below.

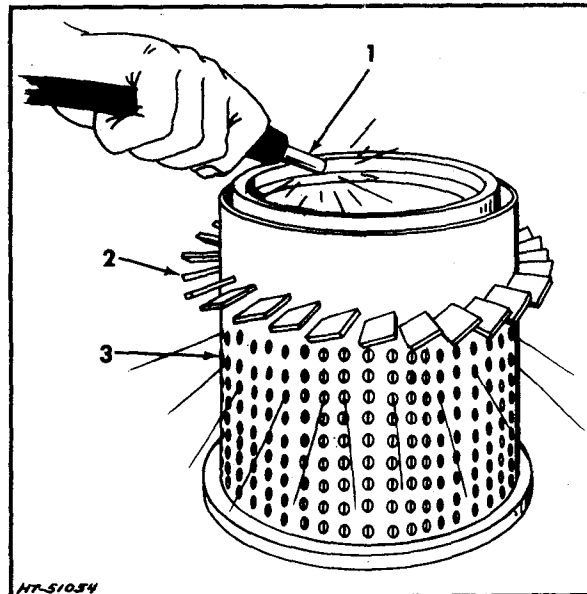

- 1. Nozzle
- 2. Pre-cleaning fins
- 3. Filter element

Figure 4. Dry Cleaning Filter Element

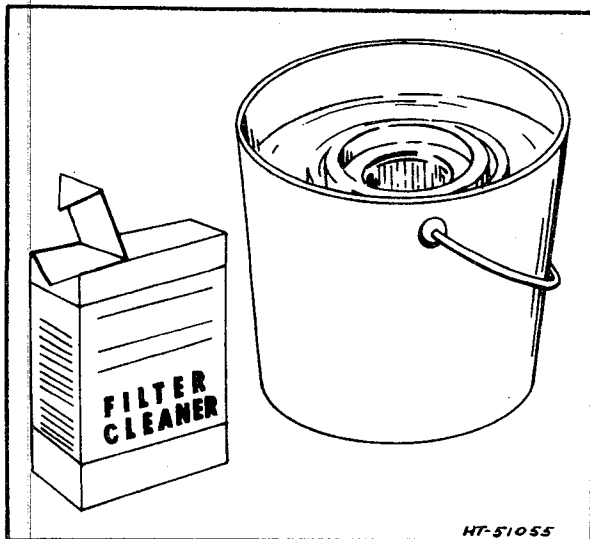

Figure 5. Washing Filter Element

**CAUTION:** Pre-cleaning fins on filter element are not removable.

- (a) To dry clean filter element, direct a jet of dry clean air up and down pleats on clean air side of element.

**CAUTION:** Air pressure at nozzle must not exceed 100 psi (689 kN/m<sup>2</sup>). Maintain reasonable distance between nozzle and filter element.

- (b) If filter element is oily and soot laden, wash it in filter cleaner available from Allis-Chalmers dealers. For best results, mix 2 ounces (56.70 g) of cleaner with a small amount of cool tap water. Add warm (70° to 100°F) (294 to 311 K) water until total volume equals one gallon (3.79 lts). The warmer (100°F) (311 K) the solution, the better it will clean. Soak element for 15 minutes, then remove it and rinse thoroughly with clean, running water (maximum pressure 40 psi) (276 kN/m<sup>2</sup>). Air dry thoroughly before reusing. (A fan or air draft may be used for drying, but do not heat element to hasten drying.)
- (c) Inspect for damage by placing a bright light inside element (Fig 6). Thin spots, pin holes or the slightest rupture will render the element unfit for further use.

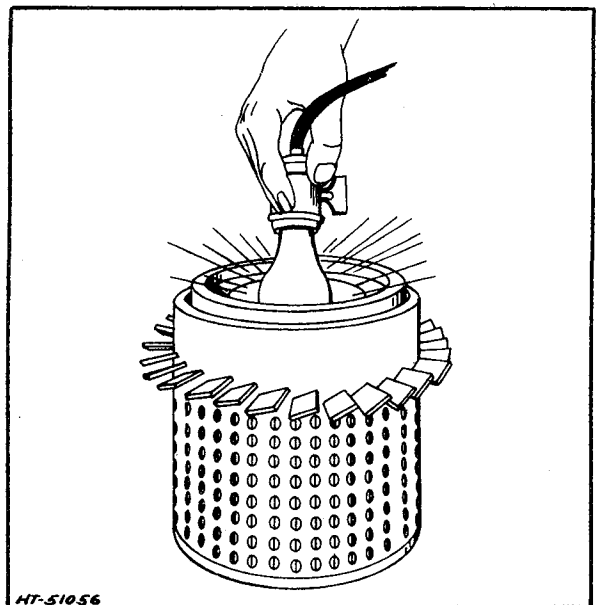

Figure 6. Inspecting Filter Element

**NOTE:** Replace filter element after 6 cleanings.

## 2. Donaldson Air Cleaner - Two Element Type.

The Donaldson air cleaner with the outer and inner elements (Fig 7), and the dust and moisture unloader valve is designed for minimum maintenance, double protection (2 elements) and automatic dust and moisture elimination from the air cleaner dust cup by the action of the unloader valve.

### a. Air Cleaner Service

- (1) The unloader valve located on the bottom of the air cleaner dust cup must be kept free from debris. Check the lips periodically and keep them clean; lips should be open only when the engine is at low idle or stopped. If the lips of the valve have been sucked into the air cleaner, check for a plugged air cleaner inlet. Malfunction of the valve will reduce the element service interval because of backward air flow through the valve but will not affect the air cleaner effectiveness.
- (2) Service the outer element and dust cup as described in the preceding Paragraph 1, Subparagraph a, titled, Air Cleaner Service - Single Element Type.

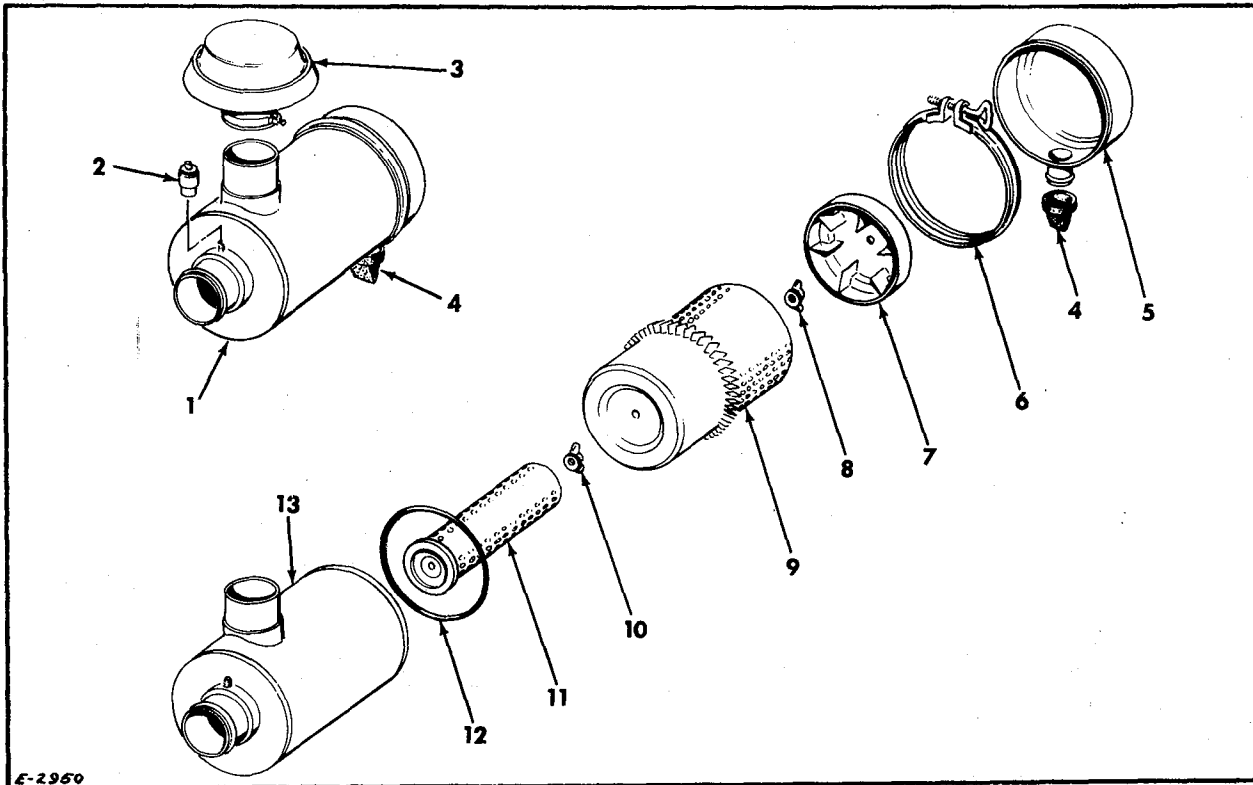

- |                         |                   |                                  |
|-------------------------|-------------------|----------------------------------|
| 1. Air cleaner assembly | 6. Clamp assembly | 11. Inner element (safety)       |
| 2. Service indicator    | 7. Baffle         | 12. Gasket - dust cup to housing |
| 3. Inlet cap            | 8. Wing nut       | 13. Housing                      |
| 4. Dust unloader valve  | 9. Outer element  |                                  |
| 5. Dust cup             | 10. Wing nut      |                                  |

Figure 7. Donaldson Air Cleaner - Two Element Type

**NOTE:** Replace filter outer element after 6 cleanings.

- (3) The inner element is not to be cleaned. Replace it after each third outer element replacement or if the service indicator signal indicates a clogged filter after a new or cleaned outer element has been installed.
- (4) To replace the inner element, remove the dust cup and outer element.
- (5) Unscrew wing nut and remove inner element from housing.
- (6) Make certain the interior of the housing is clean and the housing-to-dust cup gasket is in good condition and properly seated in the groove of the cleaner housing.
- (7) Install inner element and tighten the element retaining wing nut

securely.

- (8) Install the outer element and dust cup in the reverse order of removal.
- (9) Make certain the lips of the unloader valve are not turned inward and that no debris is stuck between them.
- (10) Reset the service indicator. Start the engine and observe the service indicator with the engine running at a high idle speed. The indicator red signal should not be in sight which indicates the air cleaner has been properly cleaned.

### 3. FARR Air Cleaner

The Farr air cleaner (Fig 8) consist of a housing, cartridge moisture eliminator, and a precleaner with self-cleaning dust bin. Dust is automatically ejected from the precleaner dust bin through the flexible discharge valve. A service indicator is also included.



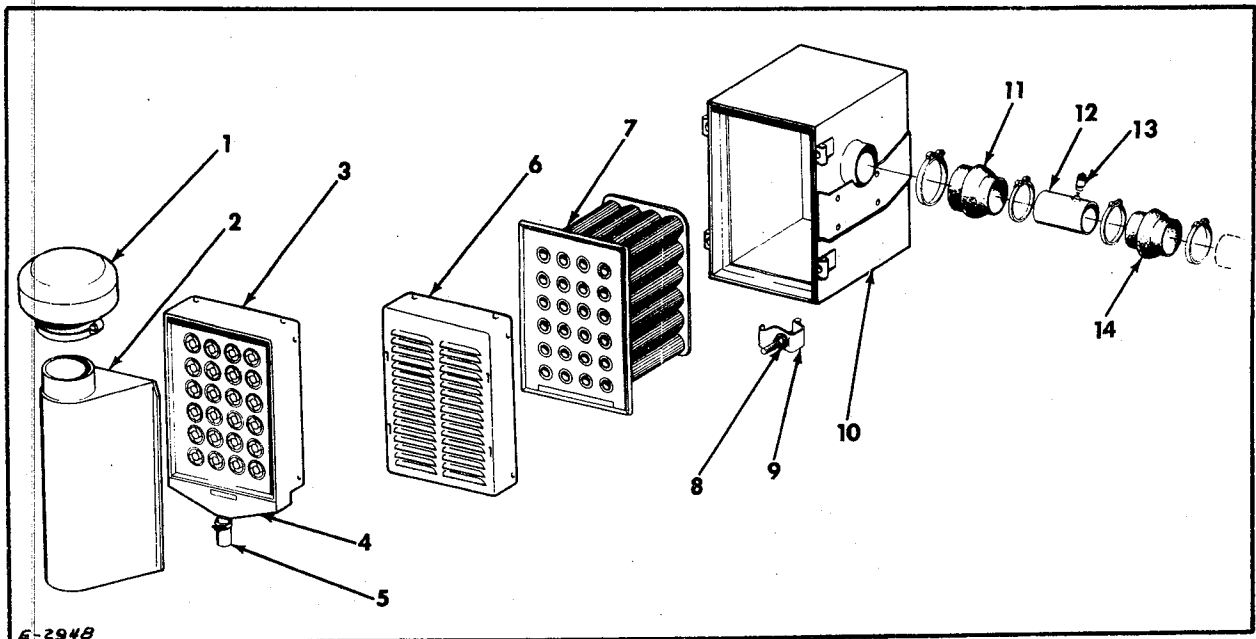

- |                         |                        |                       |
|-------------------------|------------------------|-----------------------|
| 1. Rain cap             | 6. Moisture eliminator | 11. Reducer adaptor   |
| 2. Vertical air inlet   | 7. Cartridge           | 12. Tube              |
| 3. Precleaner panel     | 8. Fastner             | 13. Service indicator |
| 4. Dust bin             | 9. Clamp               | 14. Flexible adaptor  |
| 5. Dust discharge valve | 10. Housing            |                       |

Figure 8. Farr Dry Type Air Cleaner

Periodic inspection of air cleaner body for dents, cracks, etc., should be made. Also check for damaged hoses, loose hose clamps, damaged gaskets, or any kind of leak that allows air to enter engine without first passing through the air cleaner. If any of the above conditions exist immediate corrective action must be taken.

Do not clean the cartridge. Experience has shown that attempting to clean a dirty cartridge by washing, shaking, or compressed air, frequently results in damage to it. Internal damage caused by cleaning often is too minute to be seen, or may develop after re-installation.

Under normal conditions the pre-cleaner is self-cleaning, however, under extreme conditions the pre-cleaner may require cleaning. It may be cleaned by steam cleaning, washing, or by blowing air through the front and back of the cyclonic tubes and dust bin.

If necessary, the moisture eliminator can be cleaned in a similar manner as the pre-cleaner, making certain all foreign matter and cleaning solutions are drained out through the holes in the bottom of it.

Replace cartridge and clean air cleaner as follows:

- (a) If applicable loosen clamp fasteners on the air cleaner housing and remove the vertical air inlet adaptor and rain cap.
- (b) Remove the moisture eliminator or pre-cleaner depending upon specification of the air cleaner.
- (c) Insert fingers into element openings and loosen all four corners of the element one at a time by pulling straight out at each corner. After seal has been broken, remove element by pulling it straight out and slightly up so it clears the sealing frame. Discard dirty element.

NOTE: Do not clean or reuse dirty element. Inspect dirty element for soot or oil. If there is soot inside the tubes, check for leaks in the engine exhaust system or exhaust from other equipment. If the element appears to have an oily film, check for fumes escaping from the breather tube. Correct any of these conditions, if necessary, before a new element is installed.

- (d) Inspect inside of cleaner and if applicable the pre-cleaner dust discharge valve and remove all foreign

matter.

**CAUTION:** Inspect new element for shipping damage before installation.

- (e) Install new cartridge into housing. Avoid hitting the cartridge tubes against the sealing flange of the housing. Firmly press all the edges and corners of the cartridge against the sealing flange with your fingers to effect a positive air seal.

**CAUTION:** Do not pound in the center of the cartridge to effect a seal.

- (f) Tighten fasteners to 72 lb-in (8 Nm) torque. If a torque wrench is not available tighten each fastener finger tight, then turn fastener one and one-half turns using a suitable tool. Do not tighten fasteners in direct sequence to assure a uniform seating procedure.

**NOTE:** If, at a later date, inspection of the fasteners indicates that they are slightly less than the specified torque, this is due to a slight set in the plastic face of the element and does not impair the seal between the element and the housing. Retightening of the fasteners is not recommended, unless they are loose, as this may break the seal which has been formed.

- (g) Make certain all connections are tight.
- (h) Reset service indicator by pressing reset button on top of indicator (Fig 9).

### C. AIR FILTER SERVICE INDICATOR

Purpose of the service indicator (Fig 9), which is factory set, is to provide a visual signal when the air cleaner is in need of servicing. The operator can ascertain the degree of filter contamination by observing the indicator during periods of actual engine operation.

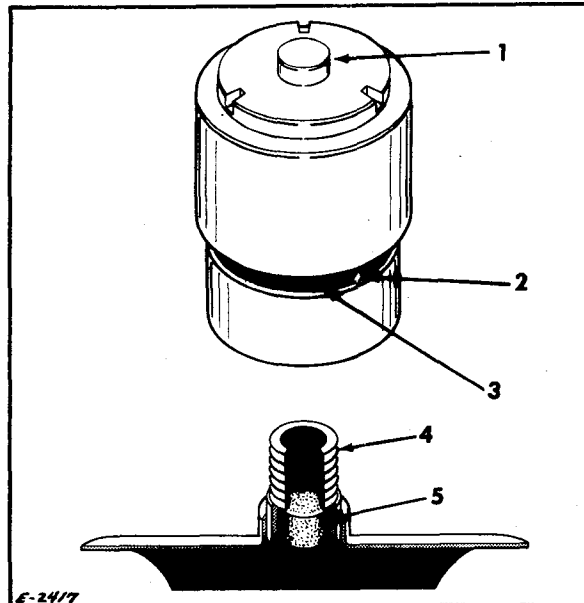

1. Reset button
2. Red signal
3. Window
4. Connector with sintered filter
5. Sintered filter

Figure 9. Air Filter Service Indicator

Dirt trapped by the air cleaner gradually reduces volume of air flow through the filter and increases the air cleaner-to-engine pressure drop. As pressure flow decreases, the red signal of the filter indicator gradually moves in the window and when fully exposed is locked in position. At this time the air cleaner should be serviced or the element replaced or serviced. After servicing, reset signal by pressing reset button located on top of the service indicator.

Indicators are connected to the outlet side of the air cleaner by a connector that contains a sintered filter. If seals in the indicator rupture, the filter in the connector will prevent dust and other foreign material from entering the engine. If seals are damaged, the service indicator must be replaced.

## TOPIC 18. TURBOCHARGER

### A. GENERAL

AiResearch Model T-04B turbocharger is applied to engines with dry exhaust manifolds and Model T-04 to engines with water cooled exhaust manifolds. The turbocharger is used to boost the power output of an engine over that of a naturally aspirated engine by increasing the supply of air to the cylinders. The turbocharger is a highly efficient, yet rugged and easy to install, exhaust-driven blower. The simple, compact design of the turbocharger incorporates a single stage radial inflow turbine wheel, mounted on a common shaft with a single stage centrifugal compressor impeller. It has a one-piece bearing housing with floating sleeve type bearing, a turbine housing and a compressor housing. All rotating parts are individually precision balanced.

### B. OPERATION

During engine operation, air enters the turbo-

charger at center of compressor housing, Figure 2, and is discharged from compressor outlet to the intake manifold. After combustion, the exhaust gases enter the manifold and flow to turbine side of the turbocharger. The expanding gases flow rapidly through the turbine housing causing turbine wheel to spin. The turbine wheel drives the compressor impeller which is mounted on the same shaft.

The turbocharger responds to engine load demands by reacting to the flow of expanding exhaust gases and supplying a correlated volume of air to the engine cylinders. During a heavy load/lugging operation, the increased flow of exhaust gases turns the turbine wheel faster, causing the compressor impeller to turn faster to supply more air to the intake manifold. Conversely, when engine load is light and the radial flow of gases within the turbine decreases, the turbocharger compressor reduces the supply of air to the intake manifold.

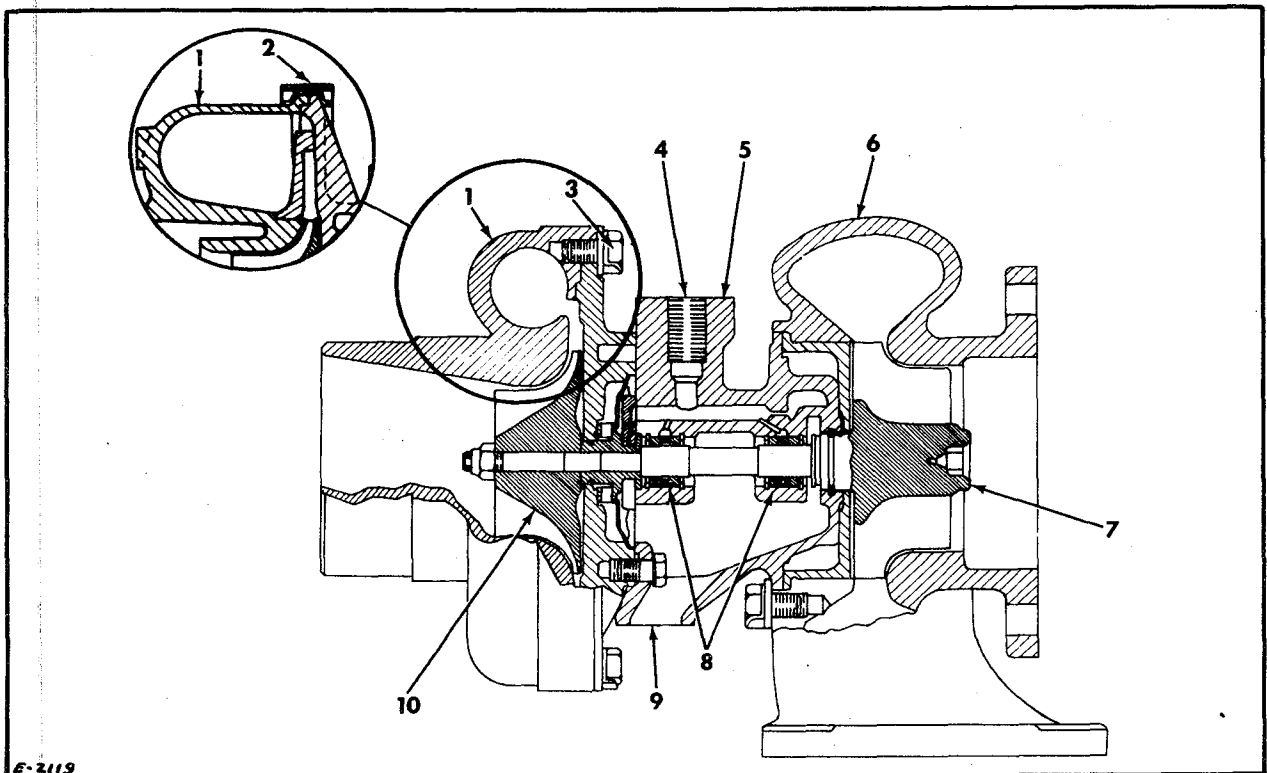

E-2119

- |  |                                      |
|--|--------------------------------------|
| 1. Compressor housing                            | 6. Turbine housing                   |
| 2. V-clamp (T-04 Only)                           | 7. Shaft wheel<br>(Turbine impeller) |
| 3. Capscrew, lockplate and<br>clamp (T-04B Only) | 8. Bearings                          |
| 4. Oil inlet                                     | 9. Oil outlet                        |
| 5. Center housing assembly                       | 10. Compressor wheel                 |

Figure 1. Turbocharger - Sectional View (Typical)

The turbocharger bearing is lubricated and cooled by filtered engine oil circulating through the bearing housing under normal oil pump pressure. This oil is supplied to the bearing housing through an external line from the engine main oil gallery. Oil returns to the crankcase through an external line which extends from the bearing housing to the side of the cylinder block.

**WARNING: NEVER OPERATE THE ENGINE WITH AIR INLET PIPING OR EXHAUST ELBOW REMOVED FROM TURBOCHARGER. CLOTHING OR FOREIGN OBJECTS CAN BE DRAWN INTO THE COMPRESSOR INLET. DISCHARGED CARBON PARTICLES AND HOT GASSES FROM THE TURBINE OUTLET CAN CAUSE PERSONAL INJURY.**

### C. EFFECT OF ALTITUDE ON TURBOCHARGED ENGINES

**CAUTION:** To prevent damage to the engine from excessive exhaust temperatures and turbocharger overspeeding when operating at altitudes above sea level, it is necessary to consider a reduction in the maximum fuel setting of the fuel injection pump. The amount of derating is dependent upon several interrelated factors.

Altitude affects a turbocharged engine in the amount of an approximate 1% decrease in horsepower per thousand feet (304.8 mm) of altitude until an altitude is reached at which the engine must be derated and the maximum fuel setting of the fuel injection pump reduced for one of the following reasons:

1. In a continuous type operation the turbocharger must not exceed 130,000 rpm.
2. In an intermittent type operation the turbocharger must not exceed 135,000 rpm.
3. Maximum allowable exhaust temperature is 1300°F (978 K).
4. Turbocharger cavitation (surging) cannot be tolerated.

An engine operating under conditions of continuous type loading must be derated more than an engine operating under conditions of intermittent loading where loading intervals are of a time duration that does not allow stabilization of manifold temperatures and pressures, even though both may be set to deliver the same amount of horsepower. Likewise, an engine delivering near maximum horsepower must be derated more than a similar engine set to deliver a conservative amount of horsepower.

At governed speeds, exhaust temperature increases at the rate of approximately 20°F per

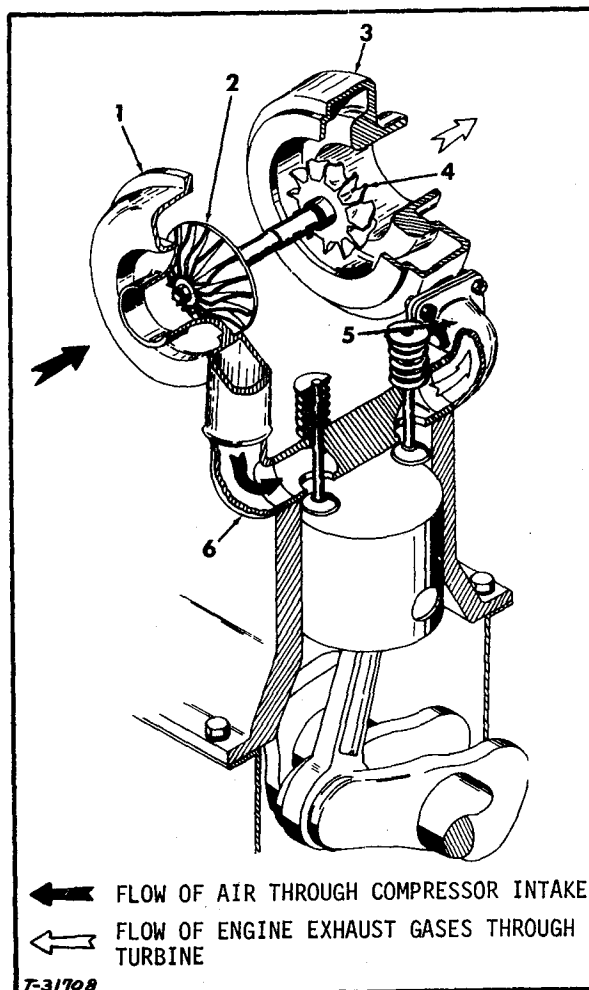

1. Compressor housing
2. Impeller
3. Turbine housing
4. Turbine wheel
5. Exhaust manifold
6. Intake manifold

Figure 2. Turbocharger Operation Diagram

1000 ft (11k per 304.8m) altitude. However, when the engine is lugged down to 1400 to 1500 rpm the temperature may increase at a rate of 35° per 1000 ft (19k per 304.8m) altitude.

Engine Model 3500MKII, equipped with the specified AiResearch turbocharger, will exceed the 1300°F (978 K) maximum allowable exhaust temperature before the maximum allowable speed of the turbocharger is reached. Therefore, as a practical field approach, safe control of turbocharger speed and exhaust temperature during altitude operation can be maintained by reducing the fuel injection pump flow, thereby limiting the exhaust temperature so that it does not exceed 1300°F (978 K).

**NOTE:** The exhaust temperature must be taken before it enters the turbocharger. The exhaust manifold is provided with a 1/4" pipe plug below the turbocharger mounting flange for installing thermocouples of temperature indicators.

#### D. MAINTENANCE

Each time engine lubricating oil and filter elements are replaced, or when routine service operations are performed, inspect turbocharger as follows:

##### 1. Air Cleaner and Intake System

Restriction in the air intake system will cause malfunction of both turbocharger and engine. The restriction is measured as a vacuum at the turbocharger air inlet, under engine full-speed, full-load conditions and it should never exceed 30" (7465 N/m<sup>2</sup>) of water.

- a. Inspect gaskets, hose connections, air cleaner-to-turbocharger inlet tubing, and clamps for loose or damaged condition that permits air leaks in system.
- b. Inspect for restrictions due to dented tubing or collapsed hoses.

##### 2. Lubrication System

- a. Replace engine lubricating oil and filter elements at specified intervals to assure clean supply of oil to the turbocharger.
- b. Minimum oil flow to turbocharger with engine running is 10 psi (69 kN/m<sup>2</sup>) with oil temperature of 180°F (355 K). Loss of engine oil pressure will quickly damage or destroy a turbocharger.

**CAUTION:** If an engine has been in storage for several months without being operated, it is recommended that the oil inlet connection at the turbocharger be removed and 3 to 4 ounces (85 to 113 g) of lubricant be placed in the oil inlet of the center housing. Also fill oil inlet line with oil. Perform the above BEFORE operating engine.

- c. Inspect oil inlet lines, drain lines, and fittings for leakage, clogging, and damage.

##### 3. Exhaust System

Total restriction of the entire exhaust

system must not exceed 2" (6754 N/m<sup>2</sup>) mercury back-pressure at the turbocharger turbine housing exhaust outlet, under engine full-speed, full-load conditions. Excessive back-pressure will reduce turbine speed and subject it to excessive temperatures.

- a. Inspect for exhaust leaks due to damaged gaskets, cracks in exhaust manifold, loose manifold mounting, or loose turbocharger-to-manifold mounting.
- b. Observe engine exhaust. Excessive smoke may indicate a restricted air cleaner or air intake pipe, over-fueling, or faulty turbocharger operation. Check air filter service indicator and maintain the air cleaner as required.

##### 4. Fuel Injection Pump

Under no circumstances should the factory maximum fuel delivery specification for the injection pump be exceeded in order to increase power output of the engine. Resulting turbocharger and engine damage will be costly and offset any benefit that might have been derived from increased engine power.

##### 5. Engine Breather System

A clogged engine breather tube will cause pressure build-up in the engine. This pressure will prevent the oil from draining down the oil return line and force it out the low pressure side of the turbocharger and into the engine air intake system.

- a. Check engine breather tube to make certain it is not clogged.

##### 6. Operating Checks

- a. Operate engine at approximate rated output and listen for unusual turbocharger noise. (Do not mistake whine heard during run-down for one that indicates impeller shaft bearing failure during operation.) Other unusual noises can result from improper clearance between turbine impeller and turbine housing. If such noises are heard, the turbocharger must be removed, disassembled, and inspected.

#### E. 2600 - HOUR INSPECTION

A major inspection of the turbocharger, by an experienced turbocharger mechanic, should be made after each 2600-hour interval of operation. This inspection requires removal of the turbocharger from the engine, and removal of the compressor housing and turbine housing from the turbocharger, to check shaft radial movement and shaft end play.

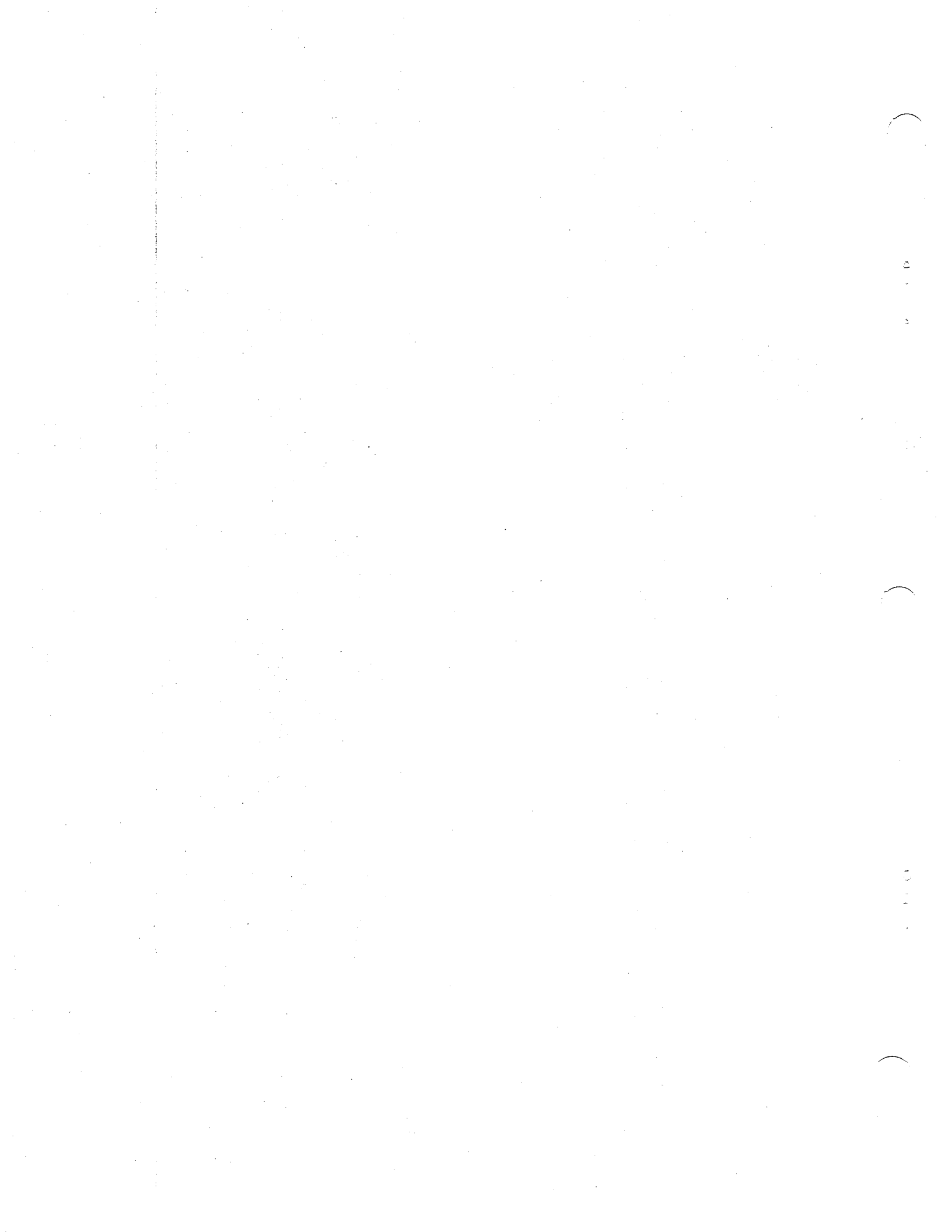

## TOPIC 19. SAFETY CONTROLS

### A. GENERAL

The purpose of the optional engine safety controls is to automatically stop the engine or audibly warn the operator to stop the engine, thereby protecting it from damage if oil pressure drops below safe operating pressure, if the coolant temperature rises above a safe pre-set limit, or if the engine should overspeed.

For information covering these safety devices, refer to the owner's manual covering the equipment being driven by the engine.

### B. DRIVE ASSEMBLY

An overspeed, cranking limit, or combination overspeed and cranking limit shutdown switches are driven by a drive assembly (Fig 1) which is driven by a gear at the center of the engine camshaft.

To remove the shutdown switch from the engine, disconnect and tag the electrical leads from the safety switch. Remove the safety switch from the angle adaptor (Fig 2 Item 1).

Remove capscrew (2), lockwasher (3), and clamp (4). Withdraw the drive assembly (5) from the cylinder block and remove the o-ring (6).

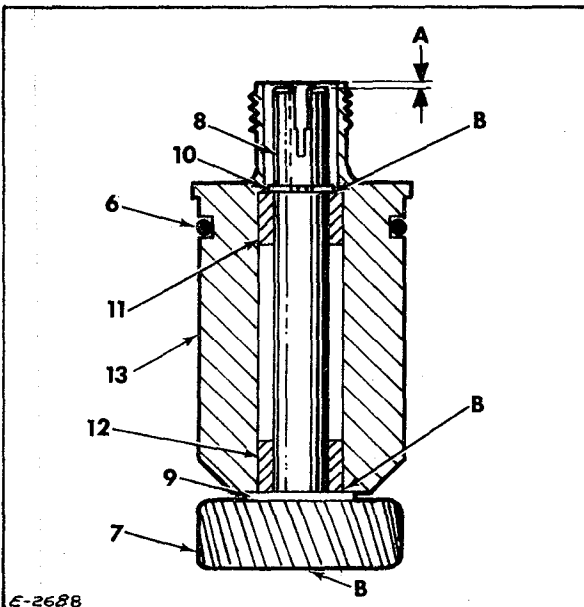

- |                         |                                   |
|-------------------------|-----------------------------------|
| 6. O-ring               | 11. Upper bushing                 |
| 7. Gear                 | 12. Lower bushing                 |
| 8. Shaft                | 13. Housing                       |
| 9. Thrust washer        | A. .030" (0.76 mm)                |
| 10. Retainer - 2 halves | B. Surfaces flush with each other |

Figure 1. Drive Assembly

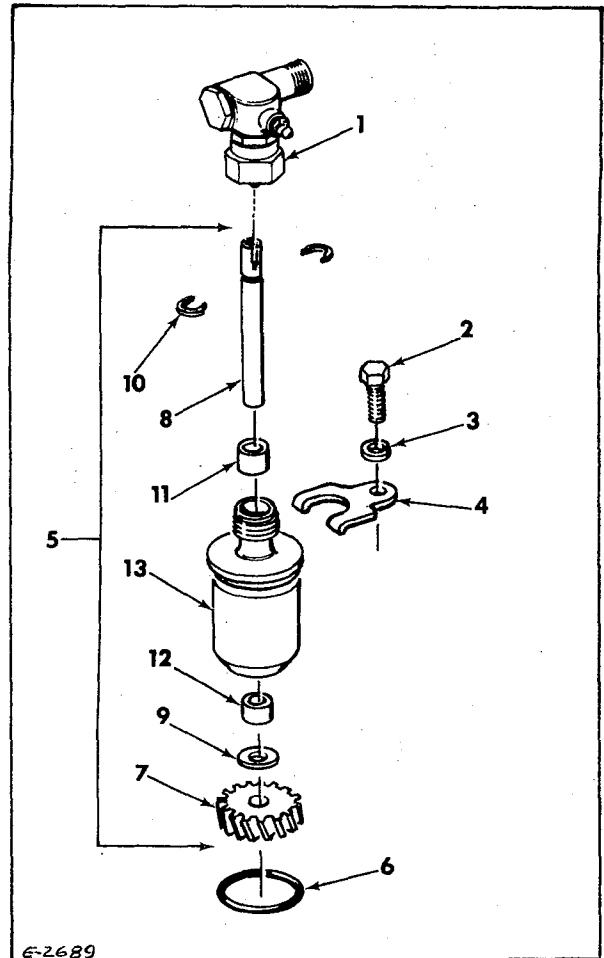

- |                   |                         |
|-------------------|-------------------------|
| 1. Angle adaptor  | 8. Shaft                |
| 2. Capscrew       | 9. Thrust washer        |
| 3. Lockwasher     | 10. Retainer - 2 halves |
| 4. Clamp          | 11. Upper bushing       |
| 5. Drive assembly | 12. Lower bushing       |
| 6. O-ring         | 13. Housing             |
| 7. Gear           |                         |

Figure 2. Drive Assembly Details

Disassemble the drive assembly (Fig 1 and 2) by placing it in a press with the threaded end down, and forcing the shaft (8) from the gear (7). Remove the 2 piece retainer (10) from the shaft. Remove thrust washer (9) and o-ring (6).

To remove the bushings (11 and 12) from the housing (13), place the housing in a press with the threaded end up. Select a drift of a diameter which will pass through the threaded end of the housing and will contact the end of the top bushing (11). Forcing the top bushing from the housing will also push the bottom bushing (12) from the housing.

Install new bushings by pressing the top bushing into the housing until it is against the shoulder. Press the lower bushing until it is flush with the bottom of the housing (B).

Assemble retainer (10) to shaft (8). Lubricate shaft with engine oil and insert into housing. Lubricate thrust washers (9) and position it on the shaft.

Place the drive assembly in a press supporting it on the slotted end of the shaft. Positioning the drive assembly in the press in this manner will permit pressing the gear (7) onto the shaft until it is flush with end of the gear

and the top of the shaft will be approximately .030" (0.76 mm) below the top of the housing. The shaft must turn freely in the housing with .001" to .035" (0.0254 to 0.89 mm) end play.

To install the drive assembly, position the o-ring (6) in groove of housing (13). Insert in the block, meshing the drive assembly gear with the gear on the camshaft. Secure position with clamp, lockwasher, and capscrew.

Assemble safety switch to drive assembly and connect electrical leads to switch.



## TOPIC 20. COLD WEATHER STARTING AIDS

### A. GENERAL

Two types of cold weather starting aids are available as optional equipment to assist engine starting in extreme cold weather. The first, is a manually operated type and the second is an electrically operated type. Both types use a very volatile type starting fluid stored in a can or tank under pressure which comply with ICC regulations.

The discharger or control is mounted on or near the engine control panel where it is accessible to the operator during startup. The spray nozzle is connected to the discharge by a length of nylon tubing. The position of the nozzle in the air intake system is such that discharged starting fluid is distributed proportionally to all engine cylinders.

**CAUTION:** Starting fluid containers are under pressure and extremely flammable. Keep away from heat, sparks, or open flame. Avoid contact with the skin and avoid breathing of fumes. Observe the precautions printed on the containers.

**IMPORTANT:** Make certain the tubing is supported and routed so it does not contact any hot surfaces or areas where it may be damaged by mechanical action or vibration.

### B. HANDLING PRECAUTIONS

**CAUTION:** When the fuel cylinder is removed from the discharger valve assembly, always keep top of valve assembly covered with the plastic cap that is attached to the chain provided with the assembly to prevent entrance of foreign material into the discharger valve assembly. If it is ever decided to remove the starting aid assembly and operate the engine without it in the air intake system, first disconnect the tube from the spray fitting. Then remove the spray fitting from the air intake system and replace it with a pipe plug.

- a. Do not heat fuel cylinders.
- b. Starting fluid contained in the cylin-

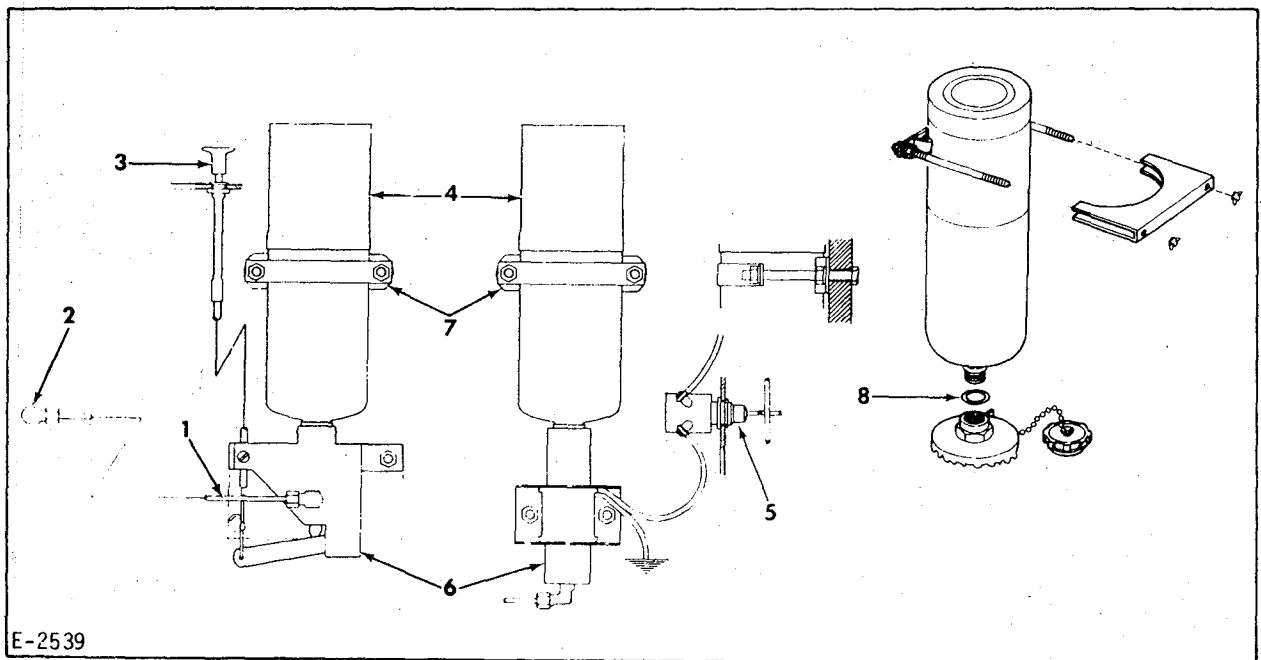

- |                         |                             |
|-------------------------|-----------------------------|
| 1. Discharge tube       | 5. Electric push button     |
| 2. Spray fitting        | 6. Discharge valve assembly |
| 3. Manual control lever | 7. Mounting clamp assembly  |
| 4. Fuel cylinder        | 8. O-ring                   |

Figure 1. Cold Weather Starting Aid

ders is volatile and highly flammable. When discharger is being tested or inspected and is not installed on engine, do not discharge spray in a confined area or near an open flame.

- c. The ether component of the starting fluid is toxic. Avoid prolonged breathing of fumes.
- d. Do not puncture or incinerate cylinder.

#### C. FUEL CYLINDER INSTALLATION

- a. Remove plastic cap from top of discharger valve assembly.
- b. Place o-ring (furnished with fuel cylinder) in metering chamber well.
- c. Install fuel cylinder by placing it in position to engage threads, and screw hand tight. Then secure cylinder with clamp. Refer to instructions printed on cylinder.

#### D. OPERATION OF DISCHARGER

- a. Crank engine with stop control in the STOP position (fuel off) for 5 seconds maximum.
- b. Set stop control in RUN position
- c. Place throttle in the FULL LOAD position, then return it to the 1/4 to 1/2 position.
- d. Crank engine with stop control in RUN position for 2 - 3 seconds.
- e. Inject one shot of starting fluid while cranking engine.
- f. To inject one shot of starting fluid:
  - (1) Electric Type:  
Push and hold starting aid button for 3 - 5 seconds.
  - (2) Manual Type:  
Pull and hold starting aid control for 3 - 5 seconds.

NOTE: If engine is equipped with safety controls, refer to Topic 19, Paragraph D, for starting procedure.

- g. Wait 2 seconds and press starter button on engine control panel.
- h. If temperature is 0°F (255K) or below, repeat steps f and g.

CAUTION: Too much ether in an engine can produce any or all of the following harmful conditions; premature detonation, with resulting undue pressures on pistons, rings, and crankshaft; "ether wash" which reduces or eliminates the oil film on the cylinder walls causing scoring or premature engine failure; and accumulations of excess ether in the intake system which can cause disastrous effects when the ether is sucked into the engine after it is running.

CAUTION: Do not use starting motor continuously for more than 30 seconds without a pause of 2 minutes to allow it to cool.

- i. Once the engine is firing on most cylinders, in one quick motion, move throttle to near the full load position and return it 1/4 to 1/2 position. This will clear the exhaust during the initial starting.
- j. After the engine is running smoothly, allow it to warm up to normal operating temperature at 1/4 throttle before applying load.

NOTE: If the throttle is left in the full load position while cranking, excessive smoke will result until the engine reaches high idle rpm.

- k. Oil pressure should be 30 to 55 psi (207 to 379 kN/m<sup>2</sup>) at full load rpm. If pressure is not within these limits, stop engine immediately and correct the trouble.

#### E. MAINTENANCE

The ether starting aid assembly is ruggedly constructed and ordinarily does not require servicing. If the assembly sustains major damage, remove and replace the complete unit.

- a. When replacing empty fuel cylinder, wipe dirt from around valve inlet and follow instructions in preceding Paragraph C. Fuel Cylinder Installation. Use care in wiping dirt from valve inlet to prevent dirt from entering valve.
- b. Periodically remove fuel cylinder and lubricate the valve.

WARNING: CONTENTS OF FUEL CYLINDER ARE TOXIC AND EXTREMELY FLAMMABLE, DO NOT DISCHARGE IN A CONFINED AREA OF NEAR AN OPEN FLAME.

- c. Periodically check all connections for leaks. Correct any leaks found.
- d. Check mounting bolts and clamp for tightness.
- e. Periodically test unit for proper functioning by disconnecting the spray fitting from air inlet system. The side of the fitting is marked (chisel mark) to indicate the location of the spray orifices. Note location mark when removing the fitting. Install the fitting with location mark on the same position.
- f. Reassemble spray fitting to tube.

g. Actuate system.

h. A fine mist-like spray should be emitted from the orifice in the spray fitting.

#### F. TROUBLESHOOTING

If an inoperable condition exists, perform the following:

- a. Check fuel cylinder for hand tightness and check fuel supply. An empty fuel cylinder weighs 17 ounces (0.48 kg), a full fuel cylinder weighs 37 ounces (1.05 kg). Make certain fuel cylinder is tight, if empty, replace it.
- b. If system is still not functioning, replace entire unit.

(

0000

(

0000

(

# ENGINE DIVISION WARRANTY

---



ALLIS-CHALMERS CORPORATION (the Corporation) warrants new engines and diesel electric systems sold by it to be merchantable and free of defects in workmanship and material at the time of shipment from the Corporation's factory. THERE ARE NO WARRANTIES WHICH EXTEND BEYOND THOSE EXPRESSED HEREIN.

The Corporation will repair or replace, at its option and subject to the following provisions, any part of its new engines and diesel electric systems that fails to conform to this warranty, provided that such part is returned to the Corporation's factory or to the Corporation's dealer authorized to handle engines or diesel electric systems, transportation charges prepaid, within the following periods:

- (1) 2 YEARS OR 100,000 MILES OR 3600 HOURS OF OPERATION**, whichever first occurs, from the date of delivery to the first user of
- Engines used for on-highway vehicles and marine pleasure boat applications, and
  - Stand-by diesel electric systems.

As to such products, the Corporation will supply all required parts free of charge. In addition, the Corporation will bear all reasonable warranty labor costs during the 2 year period, as follows:

- 100% in the case of parts subjected to no more than 50,000 miles or 1800 hours of operation, whichever first occurs, thereafter,
- 75% in the case of parts subjected to no more than 75,000 miles or 2700 hours of operation, whichever first occurs, and thereafter,
- 50% in the case of parts subjected to no more than 100,000 miles or 3600 hours of operation, whichever first occurs.

- (2) 1 YEAR OR 3600 HOURS OF OPERATION**, whichever first occurs, from the date of delivery to the first user of

- Engines used for off-highway, construction, industrial and marine commercial work-boat applications, and
- Continuous duty diesel electric systems.

As to such products, the Corporation will supply all required parts free of charge. In addition, the Corporation will bear all reasonable warranty labor costs during the 1 year period, as follows:

- 100% in the case of parts subjected to no more than 1800 hours of operation, thereafter,
- 75% in the case of parts subjected to no more

than 2700 hours of operation, and thereafter, 50% in the case of parts subjected to no more than 3600 hours of operation.

- (3) 3 YEARS OR 300,000 MILES OR 10,800 HOURS OF OPERATION**, whichever first occurs, from the date of delivery to the first user of
- Crankshafts in new engines, and
  - Engine blocks for new engines.

As to such parts, the Corporation will supply all required parts free of charge during the first 2 years or 200,000 miles or 7200 hours of operation, whichever first occurs, from the date of delivery to the first user, and thereafter the Corporation will bear one-half of the cost of such parts during the remainder of the warranty period. In addition, the Corporation will bear reasonable warranty labor costs, as follows:

100% during the first 2 years or 100,000 miles or 3600 hours of operation, whichever first occurs from date of delivery to the first user, in the case of crankshafts and blocks in engines used for on-highway vehicles and marine pleasure boat applications and stand-by diesel electric systems. Thereafter, the Corporation will not be obligated to bear warranty labor costs.

100% during the first year or 3600 hours of operation, whichever first occurs from date of delivery to the first user, in the case of crankshafts and blocks in engines used for off-highway, construction, industrial, marine commercial work-boat applications and continuous duty diesel electric systems. Thereafter, the Corporation will not be obligated to bear warranty labor costs.

The Corporation will not be obligated to bear labor costs for removing or installing engines at any time during the warranty periods set forth herein.

No warranty of any kind is made or shall be imposed upon the Corporation with respect to (1) new engines or diesel electric systems which have been subject to operation in excess of recommended capacities, misuse, negligence or accident, or have been altered or repaired in any manner not authorized by the Corporation, or (2) accessory items not manufactured by the Corporation as such items are separately warranted by their respective manufacturers.

The Corporation's liability, whether in contract or in tort arising out of warranties, or representations, instructions, or defects from any cause, shall be limited exclusively to repairing or replacing parts under the conditions as aforesaid.

---

Faint vertical text or markings along the left edge of the page, possibly bleed-through from the reverse side.

)

0 0 1 2

)

0 1 1 0

)

ALL TECHNICAL PUBLICATIONS MUST BE ORDERED FROM AN ALLIS-CHALMERS DEALER

**IMPORTANT**

Always furnish the following information (available from the engine nameplate secured to side of the engine) when ordering manuals for a specific unit.

ENGINE MODEL

ENGINE CATALOG NUMBER

ENGINE SERIAL NUMBER

A-C ORDER NUMBER

**MANUAL FOR  
CURRENT PRODUCTION UNITS**

| Model  | Parts      | Operating & Maintenance |
|--|------------|-------------------------|
| <b>Industrial Engines and Power Units</b>  |            |                         |
| G-262  | TPL-512-B  | TM-5016-A               |
| D-175  | TPL-489-C  | TM-5018-A               |
| D-262  | TPL-454-E  | TM-5018-A               |
| 2800 & 2900 MK II  | TPL-4111-2 | TM-5067-2               |
| 3500 MK II   | TPL-4108-2 | TM-5071-2               |
| 11000  | TPL-4112-2 | TM-5070-2               |
| 16000 H, 16000 MKII, 17000 MKII,   |            |                         |
| 21000 MKII, 25000 MKII   | TPL-4110-2 | TM-5069-2               |
| 61000 & 65000  | TPL-4109-A | TM-5064-A               |
| <b>Diesel Electric Systems</b>   |            |                         |
| NOTE: Diesel Electric Systems operating and maintenance (TM) manuals (-3) include a TM-5063, main alternator and voltage regulator manual. |            |                         |
| DES-90   | TPL-4108-3 | **TM-5071-3             |
| DES-125  | TPL-4112-3 | **TM-5070-3             |
| DES-175/200/220/250  | TPL-4110-3 | **TM-5069-3             |
| DES-500/550  | TPL-4109   | **TM-5064-A             |
| DES-Service Handbook   |            | *                       |
| <b>Marine Engines</b>  |            |                         |
| 25000 MKII   | TPL-4110-4 | TM-5001-A               |
| <b>Diesel Generator Drive Units</b>  |            |                         |
| D-262  | TPL-454-E  | TM-5018-A               |
| 2800 & 2900 MKI  | TPL-4111-1 | TM-5072-1               |
| 3500 MKII  | TPL-4108-1 | TM-5071-1               |
| 11000  | TPL-4112-1 | TM-5070-1               |
| 16000 H, 16000 MKII, 17000 MKII,   |            |                         |
| 21000 MKII, 25000 MKII   | TPL-4110-1 | TM-5069-1               |
| 61000 & 65000  | TPL-4109   | TM-5064                 |
| <b>Service (Overhaul) Manuals</b>  |            |                         |
| G-262 (Gasoline and Natural Gas Engines)   |            | TM-5003                 |
| D-175 & D-262  |            | TM-5049                 |
| 2800 & 2900  |            | TM-5028                 |
| 3500   |            | TM-5066                 |
| 11000  |            | TM-5034                 |
| 16000 H, 21000 H, & 25000  |            | TM-5006                 |
| 16000 MKII, 17000 MKII, 21000 MKII, & 25000 MKII   |            | TM-*                    |
| Service Labor Guide  |            | TM-5026                 |
| <b>Fuel Systems</b>  |            |                         |
| Roosa Master Fuel Injection Pump   | TPL-4059   | TM-5023                 |
| Amer. Bosch APE Type Fuel Injection Pump   | **         | TM-5035                 |
| Robert Bosch Fuel Injection Pump   | TPL-4097-B | TM-5058-A               |
| Simms Fuel Injection Pump  | TPL-4106   | TM-5061                 |
| Fuel Injection Nozzle Assemblies   | ***        | TM-5055-A               |
| <b>Special Application Manuals</b>   |            |                         |
| Turbocharger TO-4 Series (Airesearch)  | ***        | TM-5057-A               |
| Turbocharger T-1817, T-1818, T-1819, & T-1852  |            | TM-5074                 |
| <b>Engine Service Bulletins</b>  |            |                         |
| Historical Bulletins   |            | *                       |
| Current Bulletins  |            | *                       |
| Automotive Bulletins   |            | *                       |
| *When ordering literature not assigned a number order by description. ***Not Available   |            |                         |
| **Includes: Operating & Maintenance of Voltage Regulator & Main Alternators  |            |                         |

NOTE: When manuals are required for units not listed above, refer to Technical Publications Index, TM-5056.

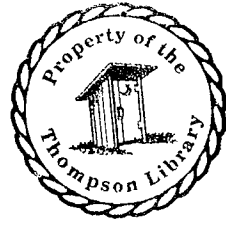



The information contained herein is general in nature and is not intended for specific application purposes. Allis-Chalmers reserves the right to make changes in specifications shown herein, add improvements, or discontinue manufacture at any time without notice or obligation.

Bunny