



Ford

INDUSTRIAL ENGINES

AND POWER UNITS

OWNER'S MANUAL
MODELS

**E "134" and D "172" Overhead Valve
Four Cylinder Engines**

OWNER'S MANUAL



**INDUSTRIAL ENGINES
AND POWER UNITS**

MODELS

E "134" and D "172" Overhead Valve
Four Cylinder Engines

Sections

General
Information
and
Description

1

General
Operating
Instructions

2

Lubrication

3

Maintenance

4

Storage and
Specifications

5

INDUSTRIAL ENGINE DEPARTMENT
FORD DIVISION
FORD MOTOR COMPANY DEARBORN, MICHIGAN

A-Alignment of Distributor		O-Oil Change	14
Shaft and Oil Pump Shaft ...	29	Oil Filter	16
Ammeter	10	Oil Level Dip Stick	15
Assembly (P. T. O.)	39	Operational Complaints	
B-Battery	33	and Corrections	50
Battery Service	35	P-Parts and Service	1
Before Placing Your New		Power Take-Off	20
Engine in Operation	7	Power Take-Off Clutch	
Break-In Procedure For		Adjustment	43
Your New Engine	7	Power Take-Off Dis-	
C-Carburetor Adjustment	38	assembly	39
Carburetor Air Cleaner	17	Pressure Cap Testing	28
Checking Battery Electro-		R-Radiator Pressure Cap	27
lyte	33	Reading Your Hour	
Checking distributor cen-		Meter	11
trifugal advance	29	Removing Ignition	
Choke Control	8	Points	30
Coolant Flow	26	S-Servicing Air Cleaner	18
Cooling System	25	Setting Basic Ignition	
Cooling System Protection	26	Timing	28
Crankcase Ventilating		Setting Governor En-	
System	19	gine Speed	46
D-Description	3	Setting Ignition Timing	
Distributor	19	With Timing Light	30
Draining the Cooling		Spark Plugs	35
System	27	Specifications	60
E-Engine Oil Pressure Gauge ..	8	Starting Your Engine	8
Engine Specifications	63	Stopping Your Engine	9
Engine Speed Control		Storage - For Indefinite	
Governor	45	Period	59
F-Fan and Generator Belt		Storage - One Month	59
Adjustment	37	T-Thermostat Checking	
Fuel	11	and Replacement	27
G-General Specifications	60	Throttle Control	8
Generator	17	Tightening Cylinder Head	
H-Hour Meter	10	Cap Screws	48
I-Ignition Complaints	32	Transmission	21
Inspection	39	V-Valve Grinding	47
Installing and Adjusting		Valve Tappet Adjustment	46
Ignition Points	31	Valve Timing	48
Introduction	1	Warming Up Your Engine	8
J-Lime or Alkali Water			
Conditioner	26		
Lubrication Chart	22		

General Information and Description

Your Ford Industrial Heavy Duty Engine or Power Unit was inspected before leaving the factory. However, certain checks should be made before putting it into operation. Read the instructions on page 3. If you plan to store the unit before using it, read the Storage Instructions on page 3.

A plate (fig. 36) is affixed to each engine. The plate contains a number indicating engine type, the serial number, and a number indicating optional equipment. When ordering parts, or carrying on correspondence concerning the engine, mention all three numbers.

PARTS AND SERVICE

Ford Industrial Heavy Duty Engines are available through the Industrial Engine Department, Ford Division, Ford Motor Company, Dearborn, Michigan, and also from Ford Industrial Products Dealers in the United States, and from Ford International Division's Branches and Dealers in principal foreign countries.

Replacement parts can be obtained through your local Ford Industrial Products Dealer or by writing directly to the Industrial Engine Department. Replacement parts having an application common to Ford Truck Engines may be obtained from local Ford Dealers.

Ford Industrial Products Dealers are equipped to perform major and minor repairs and furnish technical service advice. A manual

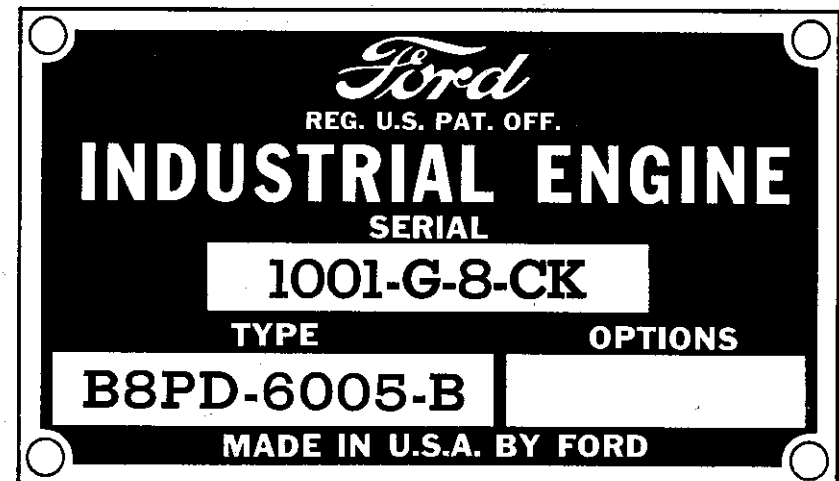

Engine Identification Plate

covering overhaul and repair procedures is available to owners that elect to perform their own repairs. Information relative to obtaining this manual may be had by writing to:

Industrial Engine Department
Ford Division
Ford Motor Company
Post Office Box 135
Dearborn, Michigan

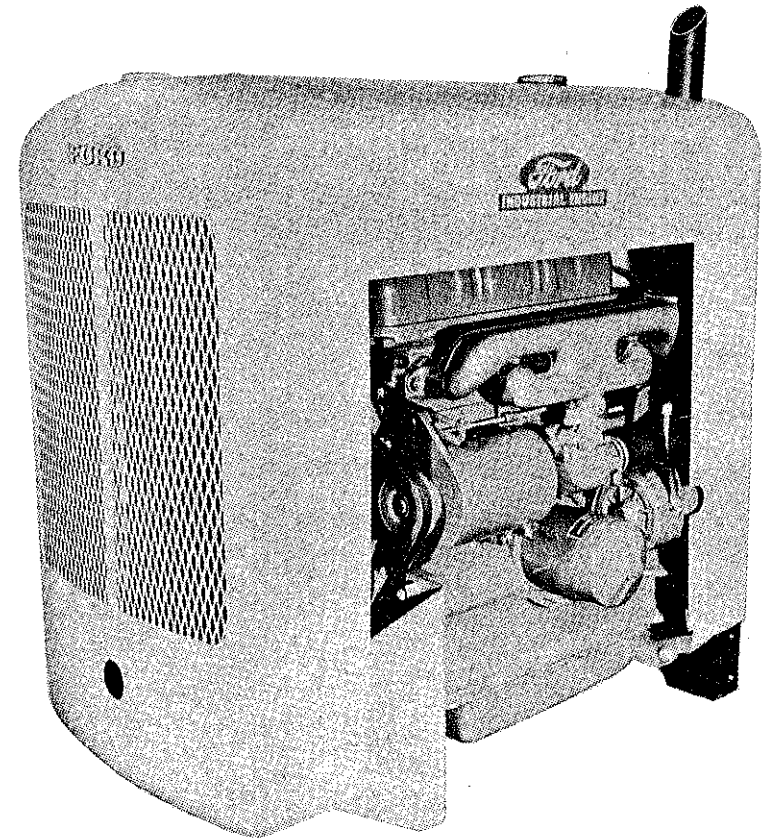

Figure 1 Ford Industrial Engine Power Unit
Model E and D - 134 and 172 Cubic Inch Engine

DESCRIPTION

Model E or D low-friction, short-stroke, high-compression, overhead valve, four cylinder industrial engine is the most modern industrial power plant in its field.

This engine is available as either a complete power unit, or an engine assembly. Power unit hood is made of heavy gauge steel.

Equipment available includes a heavy duty clutch, S. A. E. number four or five flywheel housing, over-center power take-off clutch, Ford standard flywheel housing with three or four speed transmission, combination pressure and temperature control safety switch.

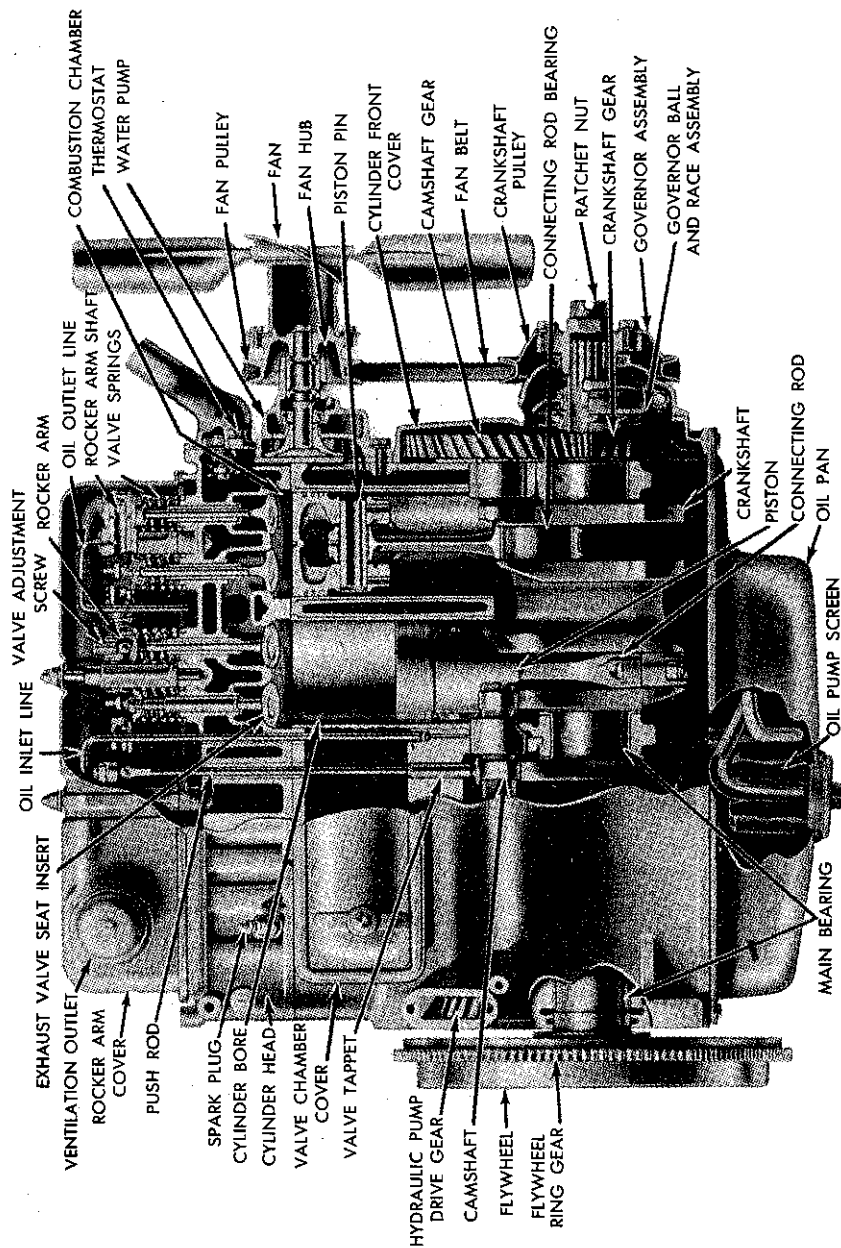

Figure 2 Sectional View of Engine

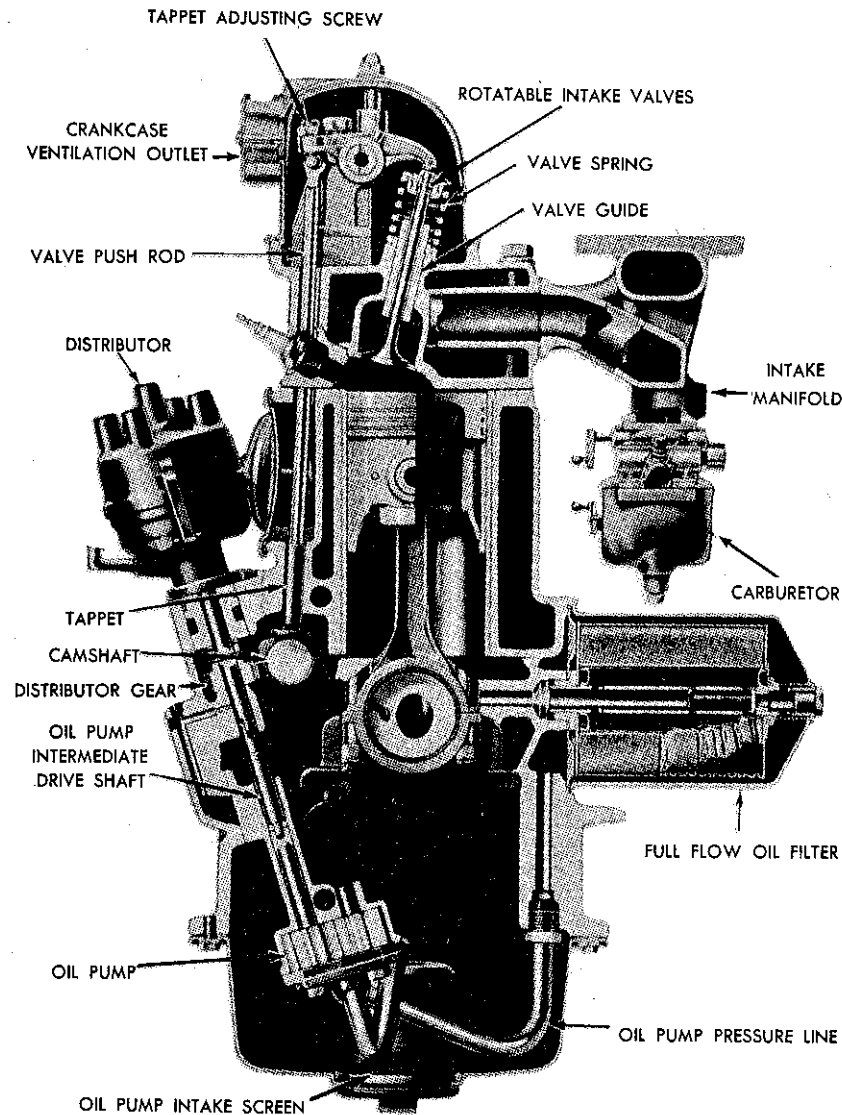

Figure 3 Cross Section of Ford 134 and 172 Cubic Inch Four Cylinder Overhead Valve Industrial Engine

GENERAL OPERATING INSTRUCTIONS

BEFORE PLACING YOUR NEW ENGINE IN OPERATION

Before placing a new engine in operation, it must be thoroughly inspected to make sure it is not externally damaged. Make certain the function of each control and instrument is thoroughly understood before operating your new unit.

Open the drain cock at the bottom of the radiator; then insert a water hose into the filler tube opening to thoroughly flush the radiator. After flushing the radiator, close the drain cock at the bottom of the radiator; then refer to "Cooling System Protection" and refill the radiator for prevailing seasonal temperature.

Before your engine is shipped from the factory, it is inhibited with a special rust preventive oil. Under variable operating conditions, such as your industrial engine will be subjected to, we recommend the use of this rust preventive type oil that conforms to Ford Specification M-4834-A, Army 2-126 Grade 1 type, or equivalent, for at least the first 15 hours of operation. Pull out the dip stick to check oil level in crankcase. If oil is needed to bring it to the full mark, refer to oil change to determine the grade and type of seasonal viscosity oil. Visually inspect the transmission or power take-off for being completely lubricated.

BREAK-IN PROCEDURE FOR YOUR NEW ENGINE

Before breaking in your new engine, certain precautions should be followed so that the engine is not damaged in the first few hours of operation. On a new engine always use rust preventive type oil, Ford Specification M-4834-A, Army 2-126 Grade 1 type, or equivalent, for at least the break-in period. Change oil as instructed under "Oil Change" and use the grade recommended for prevailing temperatures. Always use an oil that is refined by a reputable refinery.

After making sure that the cooling system and crankcase are filled, start the engine and accelerate it to approximately 1200 Revolutions per Minute. At this speed, cylinder walls are thoroughly lubricated by oil squirting out of the oil squirt hole in connecting rods. Oil from this source becomes ineffective at low speeds; therefore, during the break-in period cylinder walls may run dry if permitted to operate at a low engine R. P. M., causing overheating and, eventually, scuffing of piston rings and cylinder walls. After the engine has been thoroughly warmed up, it should be stopped, allowed to cool, and cylinder head bolts retightened 65-70 ft. lbs. with a torque wrench in the sequence shown in Figure 35, Page 49.

STARTING YOUR ENGINE

After the foregoing checks are completed, your engine is ready to place in operation. Turn on the ignition switch. Set the throttle so that the engine will operate at a fast idle speed. Set the choke at about half-way position. Release the load on the power take-off; or if your engine is equipped with a transmission, the clutch should be held in a released position before starting the engine. Starting your engine without releasing the clutch imposes unnecessary stress on starting motor and battery. After the engine starts, choke may have to be altered to keep the engine running. Never run a cold engine at excessive speeds during the warm-up period.

In cold weather, hard starting is a most common complaint. In most instances cold weather starting complaints could be eliminated, or minimized, by instituting preventive maintenance measures. As cold weather approaches, have your engine completely tuned up and winterized.

CHOKE CONTROL

Starting your engine in cold weather requires enriching the fuel mixture entering the combustion chamber. This is accomplished by pulling the choke button, Fig. 5, Page 9, all the way out until the engine starts; then pushing it in until the engine operates smoothly. When your engine is thoroughly warmed up, discontinue the use of the choke.

THROTTLE CONTROL

The throttle handle on the instrument panel, Fig. 5, is connected to the carburetor throttle shaft by a wire (Boden Wire) enclosed in a cable. Pulling this button opens the carburetor throttle, which in turn increases the speed of your engine. Turning the button clockwise locks the throttle at the desired speed range.

WARMING UP YOUR ENGINE

When an engine stands for some time, the friction surfaces lose most of the lubricating oil. Before moving parts can be lubricated freely, oil must reach a temperature that permits it to flow freely. Overspeeding your engine before the oil reaches normal temperatures will cause reciprocating parts to score cylinder walls due to insufficient lubrication. Always warm up your engine gradually. It only takes approximately seven to ten minutes to thoroughly warm up an engine in cool weather and if practiced will add materially to the service life of your engine.

ENGINE OIL PRESSURE GAUGE

The engine oil pressure gauge dial, Fig. 5, registers pounds

pressure of oil reaching the bearings. Periodic visual checks of this gauge are necessary when your engine is operating, to determine whether the engine's oil pressure system is operating satisfactorily. When oil is cold, it is thick. Until the engine operates at a normal temperature and thins the oil out, engine oil pressure will register above normal. On a new engine with operating temperature normal, oil pressure should register 8 to 10 pounds at idle speed, or at least 40 lbs. at 1500 R. P. M. On a worn engine, oil pressure may drop to zero at idle engine speeds. This condition is commonly caused by excessive bearing clearances, and can be remedied by installing new bearing inserts. If your engine is comparatively new, low oil pressure may be caused by the oil pump screen being clogged with sludge, a damaged oil pump, restricted oil pressure relief valve, or a defective gauge.

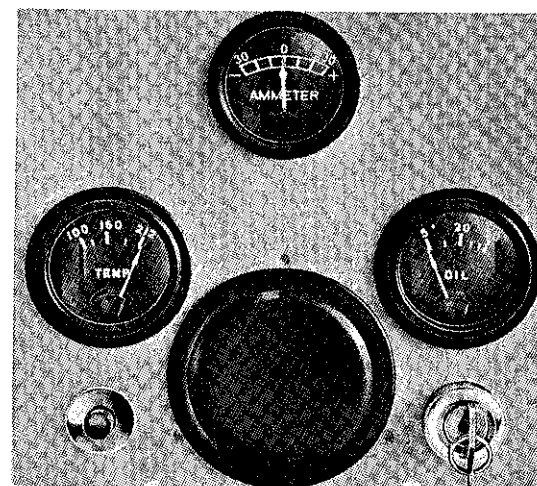

Fig. 5—Typical Power Unit Control Panel

STOPPING YOUR ENGINE

Release the load by disengaging the clutch; then turn the ignition switch key to Off position to stop your engine. If your engine has been running in an overheated condition, it is advisable not to stop it immediately. Under these conditions, run the engine at idle speed for several minutes so that the valves can cool. Suddenly stopping an engine that is overheated, lets cool air circulate around valves that are in open position. An open valve cannot dissipate heat into the valve seat, therefore, sudden cooling may produce warpage with subsequent sticking of valves when the engine is restarted. If for some abnormal condition your engine is overheated and continues to run after the ignition switch is turned off, immediately turn the switch on again and run at idle speed until

it is sufficiently cooled to stop. In an emergency, stop your engine by shutting off the fuel supply.

Never turn the ignition key off and then suddenly pull out the choke when stopping your engine. This practice is detrimental to normal service life of your engine, because raw gasoline entering the combustion chamber washes the lubricant from the cylinder walls. Under these conditions, an engine, when restarted, operates for a few moments without lubrication on the cylinder walls, thus causing premature wear of parts; and if operated at high engine R. P. M., scuffing of cylinder walls and piston rings with resultant conditions of blow-by and high oil consumption.

AMMETER

The ammeter indicates whether current is flowing into, or out of, the battery. Your ammeter will register a low charging rate when the battery is fully charged, and show a high charging rate when battery is in need of charge. The amount of current entering the battery is controlled by action of the generator regulator. If the ammeter registers discharge when the engine is running at normal speed, either the generator regulator, or ammeter are at fault and the trouble should be corrected.

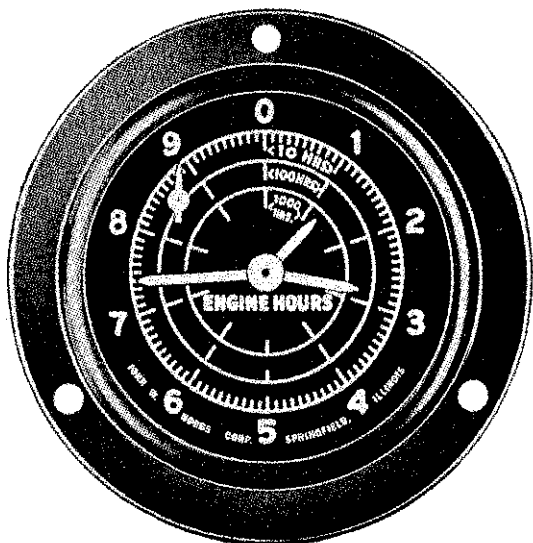

Figure 6 Hour Meter (Extra Cost Equipment)

HOUR METER

The hour meter indicates the number of hours your engine

has operated. This instrument takes the guess work out of establishing definite service intervals for your industrial unit, which will add materially to engine life. With the help of this instrument, knowing when to service your unit becomes a relatively simple matter. All you have to do is compare hours of operation against the service instruction shown in Fig. 16, Page 22.

READING YOUR HOUR METER

On the face of your hour meter dial are three rings and four hands. The ring nearest the perimeter of the dial is the 10 hour ring. This ring is graduated in increments of 10 between numbers each increment being equal to 1 hour. The middle ring is the 100 hour ring, and the ring nearest the axis is the 1000 hour ring.

The long hand makes one complete revolution every 100 hours. The intermediate hand (middle) makes one revolution in 1000 hours, and the short hand one revolution in 10,000 hours.

A glance at the small hand located near the perimeter of the dial tells whether your meter is operating. This hand makes one revolution per minute.

As an example, the hour meter shown in Fig. 6 indicates an elapsed time of 1,274 hours. The short hand has passed the numeral one but has not reached 2 on the ring nearest the axis, therefore the hand indicates 1000 hours.

The intermediate hand points between 2 and 3 on the intermediate ring. This indicates 200 hours.

The long hand points between 7 and 8 on the 100 hour ring nearest the perimeter of dial. This indicates 70 hours.

The long hand also points 4 increments past the numeral 7, indicating 4 hours. Total hours shown in the meter is 1,274.

FUEL

The volatility of gasoline is its vapor forming tendency at any given temperature. Volatility has a direct bearing on fuel consumption, power output, starting ability, and engine warm-up period. Most refineries regulate the volatility of fuel according to climate and season. Should vapor lock ever be experienced, make certain the fuel in your tank was distilled for prevailing seasonal temperatures.

NOTES

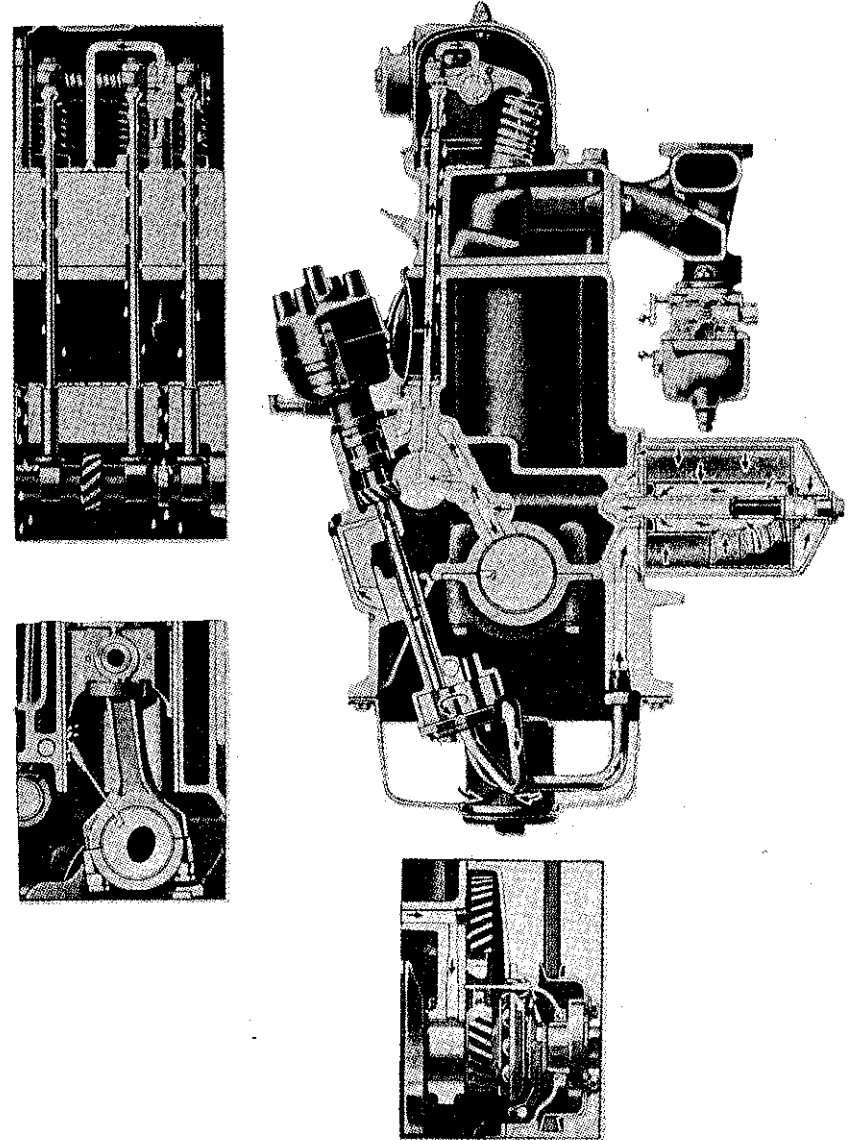

Figure 7 Models E and D Industrial Power Unit Engine Lubricating System

LUBRICATION

OIL CHANGE

Frequency of oil change and filter element replacement depends on the severity of the operation. Under normal operating conditions, oil should be changed every 100 hours; or when using premium (MM) type oil, whenever it becomes difficult to see the markings on the crankcase oil level dip stick due to the discoloration of the oil.

Heavy duty type oil (MS) is a detergent oil. Due to its cleansing action, this type oil keeps carbonaceous material in the crankcase in suspension which causes the oil to become discolored sooner than normally would be the case when using straight mineral type oil. Oil color, therefore, loses its meaning as a means of determining oil cleanliness and the necessity of filter element changes.

Unless detergent (heavy duty - MS) oil is changed with the same regularity as premium type oil, viscosity of the oil will show an increase because minute contaminants that cause the increase can only be removed by draining the crankcase and changing the filter element.

The advantage in using a detergent (heavy duty - MS) oil is that it keeps engine parts clean, making it possible for them to function normally over a longer period of time.

Detergent oil is not recommended for use if your engine has been in service for a long time using none-detergent oils, because the contaminants it loosens in the system by its purging action may cause plugging of the oil lines and oil pump screen, resulting in damage to your engine.

On a new or reconditioned engine, drain crankcase and refill with fresh oil after the first 15 hours of operation. Drain and refill again at the end of 50 hours of operation, thereafter every 100 hours of operation. When operating your engine in below freezing temperatures, change oil every 50 hours of operation. Under these conditions, make certain your engine is operating at normal temperature. Low temperature operation causes sludging, which is detrimental to engine life.

Always use premium or heavy duty type oil that will withstand elevated engine temperatures. Oils must conform to Ford Specification M-4734-A-B-C (U. S. Army 126), M-4710-20-30 (Mil-

itary 0-2104). M-4734 is a rust-preventative oil that should be used for intermittent winter service and storage and is compatible with M-4710-20-30 specifications. Use S.A.E. #30 oil for temperatures consistently above $/90^{\circ}$ F. Temperatures between $/32^{\circ}$ F. and $/90^{\circ}$ F., S.A.E. 20. Temperatures between $/10^{\circ}$ F. and $/32^{\circ}$ F., S.A.E. 20W. Temperatures between $/10^{\circ}$ F. and -10° F., S.A.E. 10W. Temperatures below -10° F., S.A.E. 5W. Models E and D 134 and 172 cubic inch engine crankcase capacity is 5 quarts refill plus one additional quart if the filter element is changed.

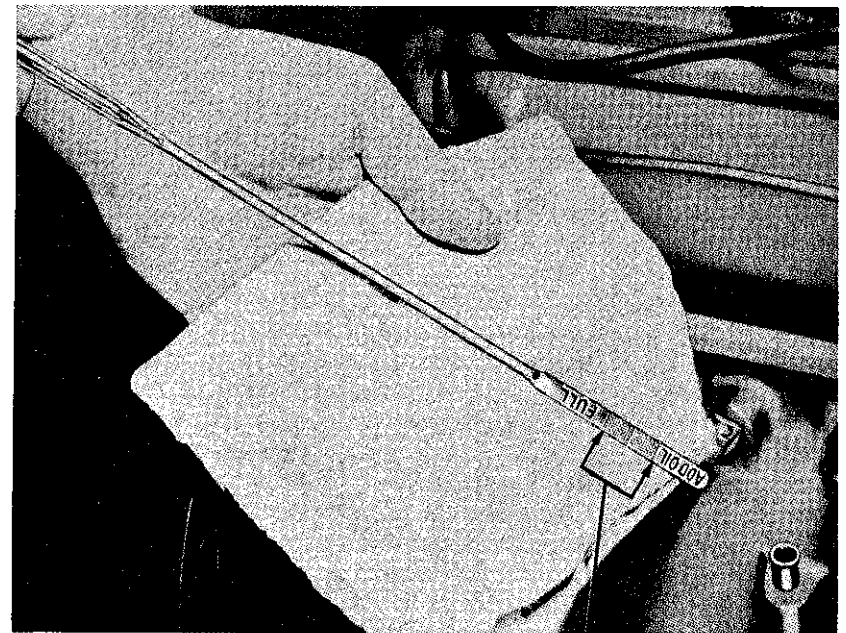

SAFE OPERATING RANGE

Figure 8 Checking Crankcase Oil Level on the Dip Stick

OIL LEVEL DIP STICK

Oil pressure indicated on your oil gauge does not show the amount of oil in the crankcase. The oil supply can become dangerously low and still show pressure on the gauge. The crankcase oil level dip stick located on right side of engine, as viewed from the flywheel end of engine, must be pulled out and oil level visually compared with the markings on the dip stick to determine the quantity needed to bring the crankcase level to the full mark. A twice daily check of your engine oil level should become habitual with the operator of your industrial unit.

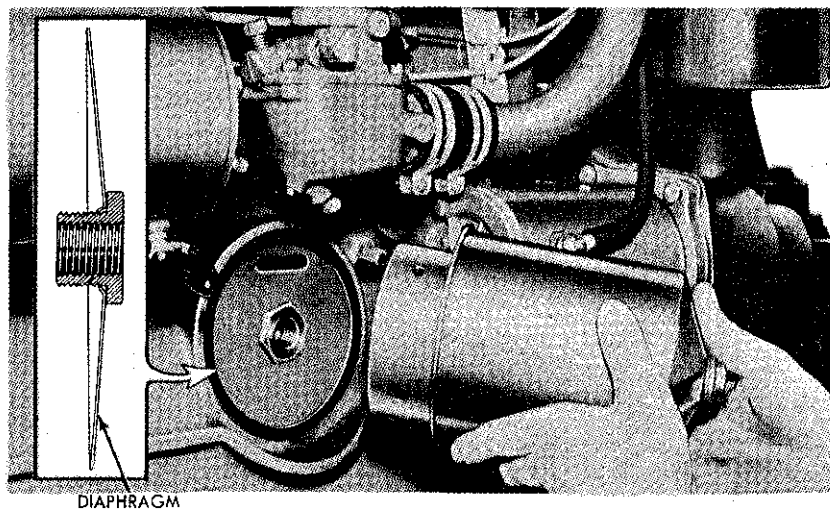

Figure 9 Replacing the Oil Filter Element

OIL FILTER

Your industrial engine is equipped with a full-flow, cartridge-type, replaceable oil filter. The purpose of this filter is to remove impurities, such as carbon, sludge, and dirt from the oil. Dirty, gritty oil on the crankcase dip stick is an indication of a clogged filter, and if allowed to circulate through the system will cause premature wear of moving parts. Due to its abrasive action, engine deposits are a greater source of trouble and expense than normal wear. Frequent changing of the oil in your engine crankcase is the best assurance for removing these contaminants, and if practiced will add materially to the life of your engine. The specially treated paper in the element makes it advisable to purchase it from your Ford Dealer. Replace the element every other oil change under normal operating conditions, or more often under dirty operating conditions. Always use new gaskets when changing the element, and make certain no leakage is evident after the engine is started. Tighten the center bolt 20-25 ft. lbs. torque. Never over tighten, as it may crush the housing resulting in leakage.

Oil is delivered, under pressure, from the oil pump through the oblong hole in the diaphragm, Fig. 9, into the oil filter. The function of the diaphragm is to prevent oil in the filter from draining back into the crankcase after the engine is stopped. Should it ever become necessary to replace the diaphragm, make certain the slot is in a horizontal position toward top of block as shown in Fig. 9.

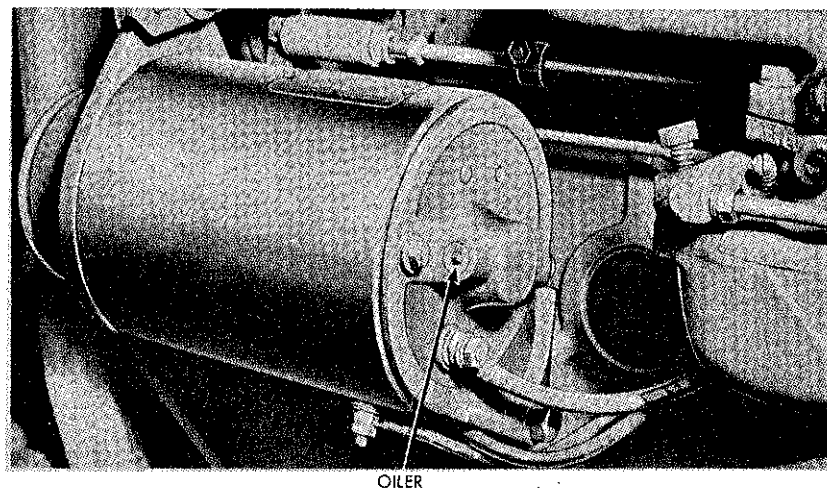

Figure 10 Generator Lubrication

GENERATOR

The generator used on Model E and D power units is a two-pole, shunt-wound, 6-volt, 20-ampere capacity, dust-proof type with the output controlled by a voltage regulator. The generator is lubricated through an oil cup located on the rear end plate. Every 100 hours inject eight to ten drops of engine oil into the oiler. Never lubricate your generator while it is in operation.

CARBURETOR AIR CLEANER

Your industrial engine is equipped with an oil-bath type air cleaner. Its function is to prevent the entry of dirt into the carburetor and engine. Air is drawn through the left side panel screen into the air cleaner and directed into the oil in the cleaner cup, then through the filtering element into the carburetor. Heavy particles of dirt remain in the cup. Small particles not retained in the cup are screened out by the filter element inside the air cleaner body. When oil in the cup becomes thick and gritty, the air cleaner is restricted and is not filtering out the dirt before it enters the carburetor. The average internal combustion engine uses about 10,000 gallons of air to every gallon of fuel. If this enormous amount of air is dirty when it enters the combustion chamber, it will quickly cut cylinder bores and piston rings, thus ruining your engines performance and oil economy in a very short time. Servicing the air cleaner regularly is one of the most important maintenance operations that can be performed to prolong the life of your engine. See Fig. 11, Page 18.

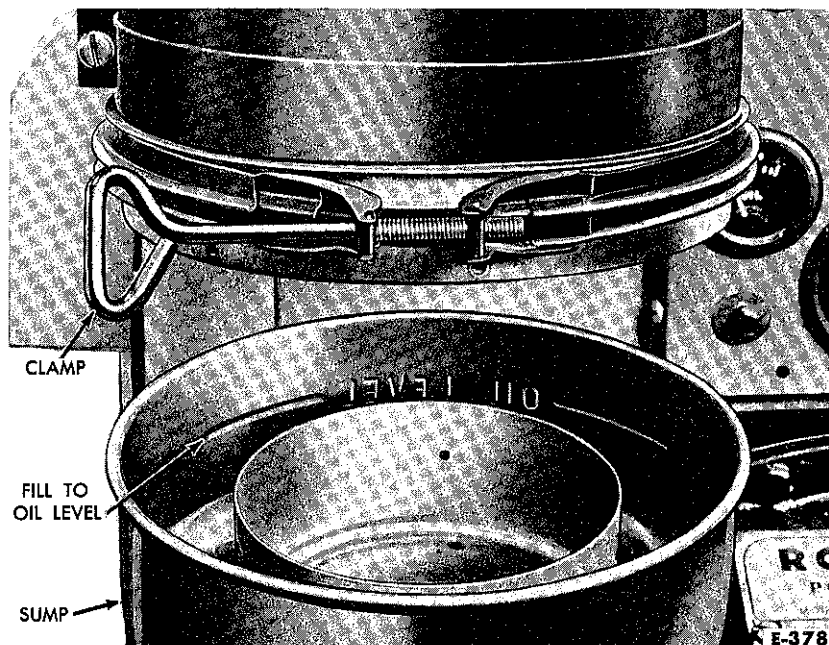

Fig. 11—Typical Power Unit Air Cleaner

SERVICING AIR CLEANER

Never use oil heavier than that used in engine crankcase for prevailing temperature. Never use diesel oil.

Inspect oil in sump daily (10 hours). If it is in a thick condition or dirt is evident, empty and clean the sump and refill with new oil. Every week remove the screened pre-cleaner and wash in solvent, because dirt accumulating on the screen restricts air flow to the carburetor. Be sure all hose connections are air tight. Under extremely dirty conditions, remove the filtering mesh every 100 hours and wash in solvent.

WARNING: If engine is operated under dusty conditions, where air is laden with dust, air cleaner must be serviced daily.

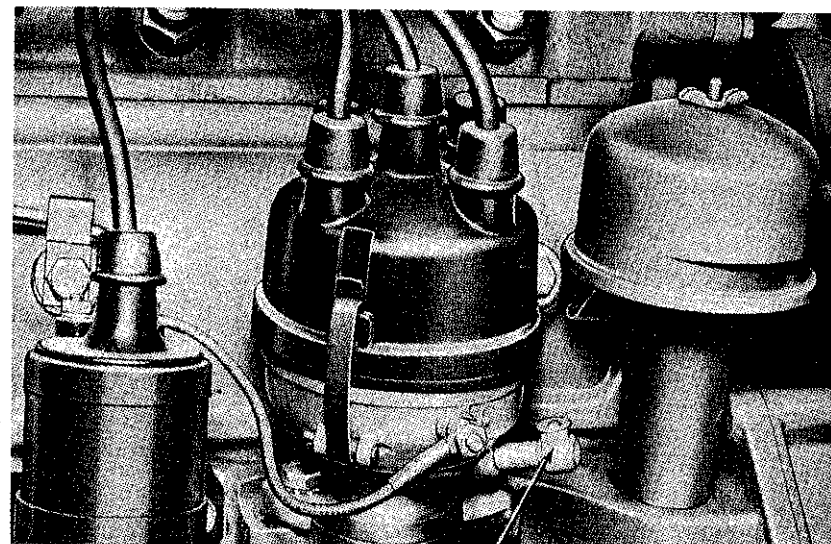

SATURATE INTERNAL WICK WITH OIL THROUGH OILER

Figure 12 Distributor Lubrication

DISTRIBUTOR

Every 50 hours inject enough seasonal engine oil into the distributor oiler to thoroughly saturate the wick. Apply a portion of lubricant about the size of a match head (M-4601 Specification) circumferentially on the distributor cam every 200 hours.

CRANKCASE VENTILATING SYSTEM

Fresh air is circulated through the crankcase so that contamination of engine oil by unburned fuel is held to a minimum.

Clean air is taken into the crankcase through the oil fill tube cap, located on the right side of engine, and expelled through the filter cap, located on the rear right side of engine rocker shaft cover. See Fig. 13, Page 20. Whenever your engines ventilating system becomes restricted, it causes abnormal crankcase pressure. This may result in oil being expelled from the oil filler tube and also leakage of the rear main bearing oil seal, or cause external leaking at the oil pan to block seams. Service the crankcase ventilating system regularly. Remove the intake and exhaust ventilating caps and wash in solvent every 10 hours, or more often

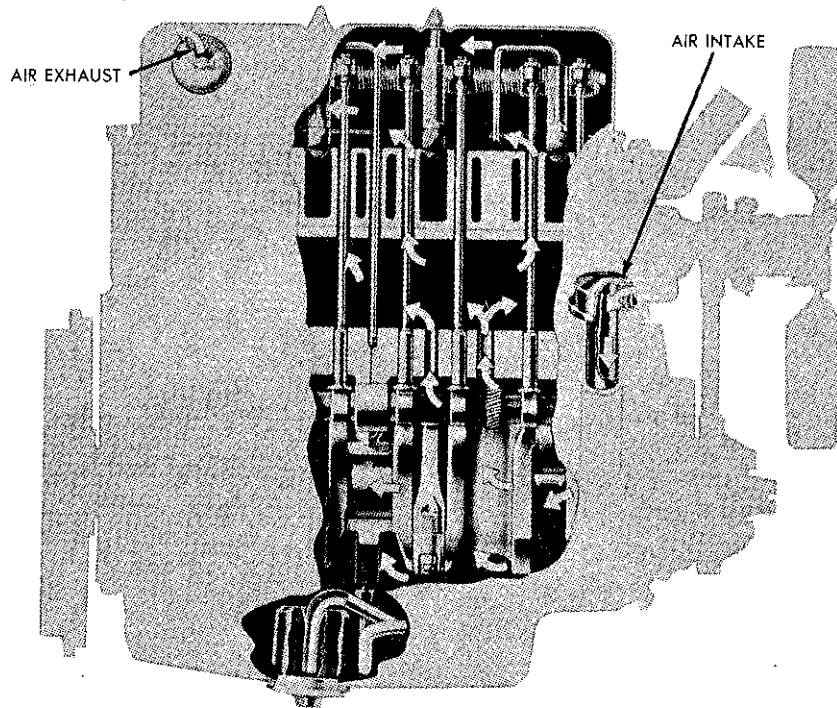

Figure 13 Crankcase Ventilating System

when operating under extremely dirty conditions. The importance of keeping the ventilating system clean in regards to engine efficiency cannot be overemphasized.

POWER TAKE-OFF

Bearing of power take-off unit should be lubricated with pressure gun every 50 hours of operation. The release bearing must be lubricated daily. Complete lubrication instructions for the power take-off are given on the patent plate attached to the power take-off clutch adjustment hand hole cover. These instructions should be carefully followed when lubricating this unit. If your engine is equipped with truck type clutch, lubricate linkage at the same interval. See Fig. 15, Page 21,

WARNING: Never over lubricate clutch pilot bearing as slippage or grabbing of clutch may result.

TRANSMISSION

Every 200 hours drain, flush, and refill the transmission with S. A. E. 140 Gear oil for summer and S. A. E. 80 for winter.

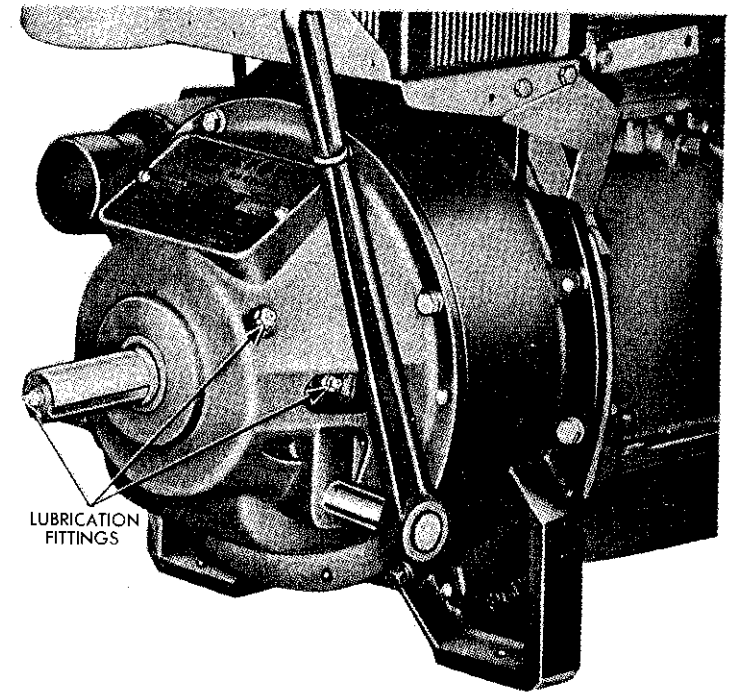

Figure 14 Power Take-Off Lubrication

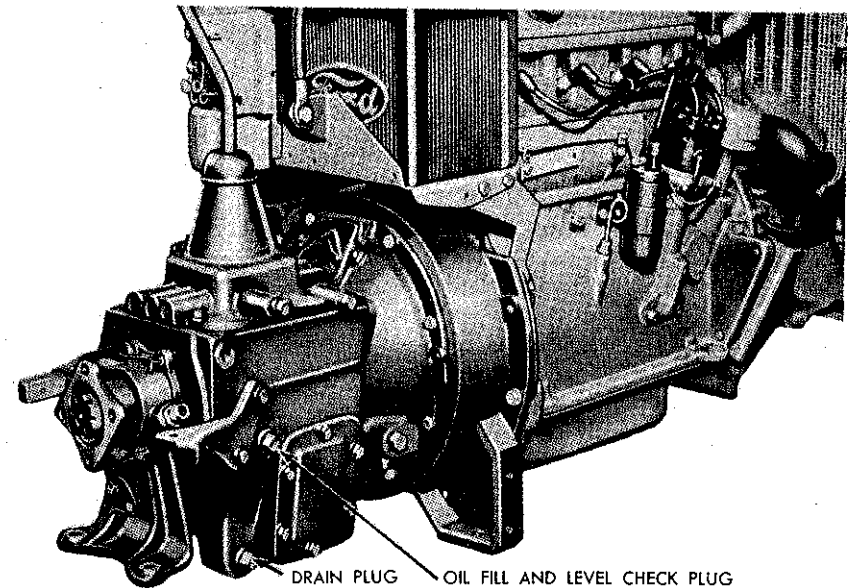

Figure 15 Transmission Lubrication

DAILY OR EVERY 10 HOUR SERVICE

Crankcase	Check oil level on dip stick. On a new or reconditioned engine, drain crankcase after the first 15 hours of operation.
Air Cleaner	Clean pre-cleaner screen if dirty. Add oil if below bead on sump. Clean, refill cup if oil is dirty.
Power Take-Off Clutch	Lubricate release bearing. Use general purpose #2 lubricant. Do not over lubricate.
Oil Fill Tube Ventilating System Breather Cap	Remove element and clean entire assembly with suitable solvent. Oil element with light engine oil.
Distributor Oil Cup	Lubricate with seasonal engine oil until wick in oiler is thoroughly saturated.
Crankcase Ventilating System	Clean ventilating system exhaust breather on rocker arm cover and crankcase oil fill tube cap in solvent. Oil with light lubricating oil.

50 HOUR SERVICE

Crankcase	If operating engine in freezing temperatures, oil should be changed at least every 50 hours.
Air Cleaner	Change oil in sump. Wash element in gasoline.
Oil Filter	Change if oil on dip stick is black due to low temperature operation.
Power Take-Off Bearings	Do not overlubricate. Use general purpose #2 lubricant.
Truck Type Clutch	Lubricate linkage. Use pressure gun.

Figure 16 Lubrication Chart

Lubrication Chart (Cont'd)

100 HOUR SERVICE

Air Cleaner Filtering Mesh	Remove mesh and wash in solvent.
Crankcase	Change oil when engine is at normal temperature. Oil and filter change, 5 qts. Crankcase only 4 qts.
Generator	Lubricate with motor oil when engine is not running. (5 to 10 drops)
Test Compression	Use compression tester.
Engine Oil Grade for Crankcase	$\geq 32^{\circ}$ F. and $\geq 90^{\circ}$ F., S. A. E. 20 $\geq 10^{\circ}$ F. and $\geq 32^{\circ}$ F., S. A. E. 20W $\geq -10^{\circ}$ F. and $\geq 10^{\circ}$ F., S. A. E. 10W Below -10° F., S. A. E. 5W

200 HOUR SERVICE

Spark Plugs	Clean, test, and regap.
Distributor Points	Replace if pitted. Install new condenser with new points.
Distributor Cam	Apply high melting point lubricant (Ford M-4601-A), about size of match head circumferentially on cam.

300 HOUR SERVICE

Valve Tappets	Check and adjust clearance
---------------	----------------------------

1000 HOUR SERVICE

Cooling System	Drain, flush, and inhibit.
Engine Oil Pan	Remove and clean.

NOTES

MAINTENANCE

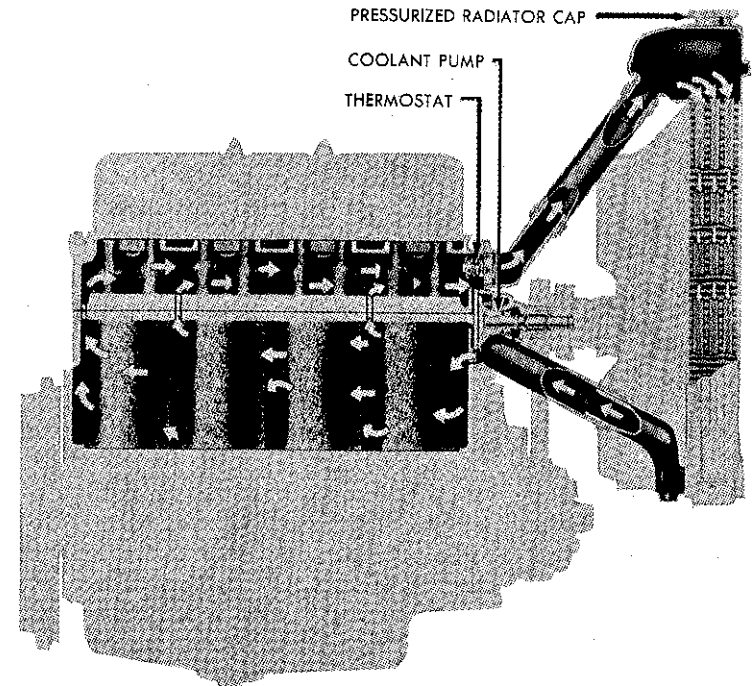

Figure 17 Model E and D Power Unit Cooling System

COOLING SYSTEM

The cooling system of your industrial engine is designed to provide adequate cooling under all normal operating conditions. If for any reason the cooling system becomes restricted, the thermostat, fan, or water pump become inoperative, or hose becomes collapsed, your engine will overheat. Combustion gasses entering the cooling system through a defective cylinder head gasket, or a radiator cap that does not provide an air tight seal and permits air to be sucked into the system, will also result in overheating. An obstructed radiator, when full, can usually be detected by running your engine at a high speed and observing whether the coolant surges out the overflow. Never stop an engine immediately that has been running in an overheated condition, or add coolant or anti-freeze to the system as this may cause a cracked cylinder block

or head. Refer to "Stopping Your Engine".

COOLANT FLOW

Before placing a new or reconditioned engine into operation with a used radiator, always check the coolant flow through the system with an accurate flow meter. Placing an engine into operation with insufficient cooling due to a plugged radiator, may ruin your engine. Coolant flow is 20 gallons per minute at 2000 R. P. M.

COOLING SYSTEM PROTECTION

In warm weather, protection against rust and corrosion is the owner's responsibility. To be fully protected, we recommend using Ford rust inhibitor compound that can be obtained from your Ford Dealer. Anti-freeze compounds include inhibitors, therefore, adding an inhibitor to the solution is not necessary.

The following chart provides a means of determining how much anti-freeze is required to protect your engine's cooling system from freezing.

System Capacity	Temperature	Ethylene Glycol
15 Quarts	20° F.	6 pts.
	10° F.	8 pts.
	0° F.	11 pts.
	-10° F.	12 pts.
	-20° F.	14 pts.
	-30° F.	15 pts.

Figure 18 Anti-Freeze Chart

If your industrial engine is operated when temperature is below 32° F., anti-freeze should be added to the cooling system. In some cases certain types of anti-freeze have been known to contain contaminants that are injurious to engines. As a protective measure, we recommend using Ford anti-freeze that can be purchased from your local Ford Dealer. If this is not available, always use an anti-freeze that is produced by a reputable manufacturer.

LIME OR ALKALI WATER CONDITIONER

If you live in a locality that has lime or alkali in the water, rain or distilled water should be used for a coolant. Deposits caused by lime or alkali water quickly build up on the cylinder walls and coolant passages in the head and in time, will cause engine overheating that may eventually result in a cracked block or head. If water containing lime or alkali must be used, add a

water softener purchased from a reputable company in the amount shown on the container.

DRAINING THE COOLING SYSTEM

Each spring and fall the cooling system of your industrial engine should be drained and flushed, then treated with a seasonal solution of anti-freeze or rust inhibitor. The thermostat should be removed prior to the flushing operation and reinstalled after the flushing operation is completed. The cooling system may be drained by opening the petcock at the bottom of the radiator and the drain cock on the left side of the cylinder block.

THERMOSTAT CHECKING AND REPLACEMENT

The thermostat is installed in the cooling system of your industrial engine to control the heat leaving the engine, so that normal engine operating temperatures can be maintained under variable climatic conditions. Automatic operation of the thermostat regulates temperature within the cooling system design limits by controlling the flow of coolant through the radiator. When the engine is cold, the thermostat valve is closed. As the coolant warms up, the thermostat is gradually opened and is fully open when normal operating temperature is reached. Generally, thermostats give little trouble, but it is good maintenance practice to occasionally check the heat range at which it opens. This is especially important if the engine has been operating in either a cold or over-heated condition. If the engine has been running continuously cold, the thermostat may be stuck in open position, or if it has been over-heating, it may be stuck in closed position. The opening and closing of the thermostat can be checked by suspending a thermometer and the thermostat in a pail of water so that neither touches the sides of the pail, then heating the water until the thermostat opens. The model E or D thermostat should start to open at 157 to 162 degrees and be fully opened at 177 to 182 degrees.

Thermostat location, Fig. 17 on Page 25, is in the cylinder head outlet casting. To remove, loosen the bottom hose clamp, remove the hose, then remove the coolant outlet casting from the cylinder head. When replacing the thermostat, make certain it is installed with the by-metal spiral of the thermostat facing toward the engine head.

RADIATOR PRESSURE CAP

Whenever pressure in the cooling system is raised above atmospheric pressure, coolant will not boil until a higher coolant temperature is reached. Incorporated in the radiator cap design is a pressure valve and a vacuum valve. When pressure in the system forces the pressure valve open, an additional 13 degree rise in operating temperature is reached before the coolant boils.

Whenever pressure in the system becomes lower than atmospheric pressure, the vacuum valve opens until pressure in the system and atmospheric pressure are equalized.

PRESSURE CAP TESTING

The radiator cap gasket must provide an absolute air tight seal between the cap and radiator fill tube at all times. The cap and gasket should be inspected regularly and replaced whenever doubt exists as to their serviceability.

If the vacuum valve is defective, the hose will collapse. A satisfactory test of the vacuum and pressure valve can be made by putting your lips over the valve cap opening and blowing on the valves. If possible to expel air through the opening, the cap is defective and must be replaced.

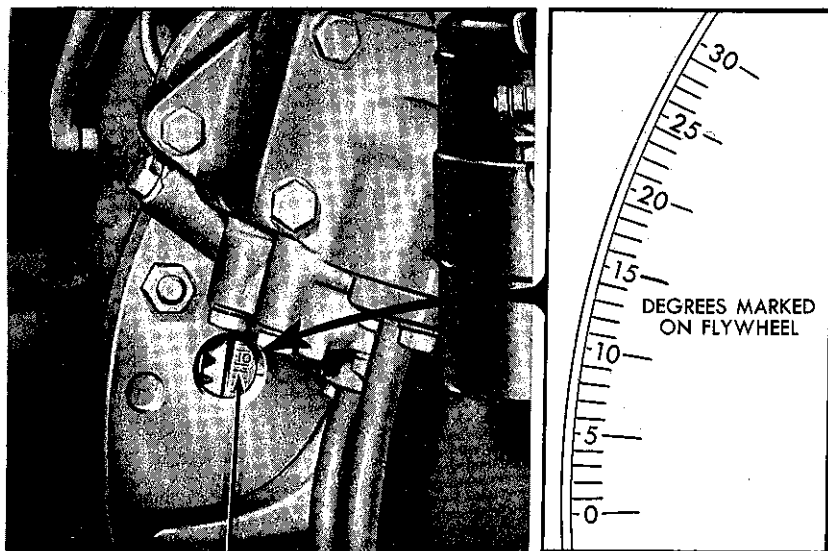

8° BEFORE TOP CENTER

Figure 19 Model E Basic Ignition Timing

SETTING BASIC IGNITION TIMING

Be sure ignition switch is in Off position before attempting to check ignition timing.

Remove distributor cap and spark plug from number one cylinder.

Hold a finger over the spark plug hole as the engine is cranked.

Observe the distributor rotor closely while it revolves, then mark its exact location on the distributor body the moment compression blows by thumb.

Press the starting button again until the rotor is almost in alignment with the rotor location mark placed on the distributor housing and compression is felt at the number one spark plug hole. Stop with the rotor in this position.

Remove the timing hole cover on the flywheel housing. Observe the location of 8° before top dead center on the flywheel for model E, 5° for D model, in relation to the timing mark on the housing. If correct marking does not align with the timing pointer, insert a screwdriver in the hole until it contacts the flywheel starting gear teeth and apply leverage on the screwdriver until the correct degree mark, depending on engine model, does align with the timing mark.

In this position, the number one piston is 8° before top dead center position for model E and 5° for model D on the compression stroke ready to fire. The ignition contact points should just begin to separate with the rotor pointing to number one spark plug wire. This is the basic ignition timing setting for the idle speed (450 R. P. M.) only.

If ignition points must be moved to obtain their separation point, loosen the clamp screw on the distributor body and turn the distributor manually.

To advance ignition timing, turn the distributor body counter-clockwise. To retard ignition timing, turn the distributor body clockwise.

ALIGNMENT OF DISTRIBUTOR SHAFT AND OIL PUMP SHAFT

If the distributor body must be turned more than ten or twelve degrees, lift the distributor from the block then turn the distributor rotor until it points to the number one spark plug wire location on the cap. Since the oil pump operates from the distributor shaft, alignment of the slot in oil pump shaft with tang on distributor shaft is necessary before reinstalling the distributor. This can be done by inserting a screw driver in the distributor mounting hole and turning the oil pump shaft. After the distributor is in operating position, be sure it is seated properly before tightening the clamp screws securely.

CHECKING DISTRIBUTOR CENTRIFUGAL ADVANCE

Correct basic engine timing does not indicate that engine spark timing is correct throughout the various speed ranges. After

engine speed reaches 500 revolutions per minute, spark advance is controlled by the centrifugal advance mechanism built in the base of distributor. The use of an accurate timing light directed on the flywheel degrees is necessary to determine whether the centrifugal advance range (above 500 R. P. M.) is correct.

Model	450 Engine R. P. M.		1200 R. P. M.		2000 R. P. M.	
	E	D	E	D	E	D
Corresponding Spark Advance	8°	5°	17-1/2° to 19-1/2°	14-1/2° to 16-1/2°	29° to 31°	26° to 28°
Crankshaft Degrees (B. T. D. C.)						

Figure 20 Distributor Centrifugal Advance Chart

SETTING IGNITION TIMING WITH TIMING LIGHT

Clip secondary lead of light to number one spark plug and leave the spark plug wire on the spark plug.

Connect primary positive lead (RED) of light to ground. Connect primary negative lead (BLACK) to "Battery" terminal of ignition coil.

Disengage clutch or place gear shift in neutral position, then start engine and run at idle speed.

Direct timing light onto flywheel through opening in bell housing and note timing marks as light flashes.

At idle speed (450 R. P. M.), timing should be 8 degrees before top dead center for model E engine and 5 degrees for D engine.

When basic timing is correct, tighten the distributor body clamp screws securely then recheck the timing again with the timing light.

REMOVING IGNITION POINTS

Disconnect the electrical lead from the coil. Release the distributor cap clips and lift the cap off. Remove dust shield assembly.

Remove the breaker contact spring screw and washer, Fig. 21. Remove the two screws and lock washers that secure the

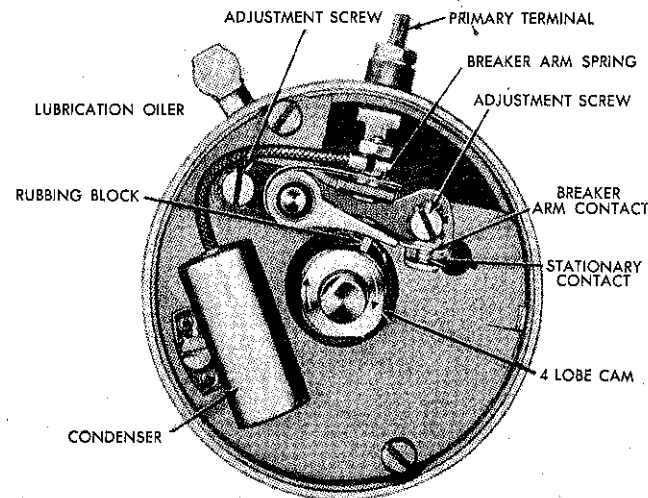

Figure 21 Model E and D Power Unit Distributor

breaker contacts to the plate assembly, and lift out the breaker contacts.

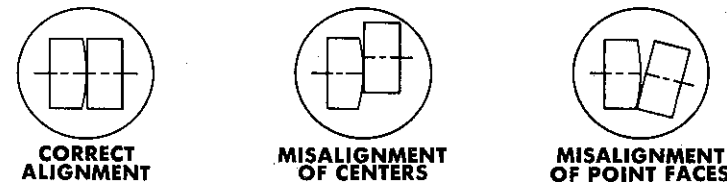

Figure 22 Ignition Contact Point Alignment

INSTALLING AND ADJUSTING IGNITION POINTS

Ignition timing should be checked each time the ignition points are adjusted or replaced. If points are replaced, always install a new condenser. When the contact points are closed, they must be parallel. Breaker points must stay closed a specified number of cam degrees to energize the coil.

If the points are not properly aligned, the degrees between the opening and closing time of the points is changed. This causes excessive heating and rapid burning of points, and also a weak spark. If points need aligning, use wrench No. 12150-A which is made specially for this purpose.

Install the ignition points in normal operating position, and secure lightly by adjusting the lock screws.

Attach the condenser and primary circuit leads to distributor point terminal. Rotate the cam until rubbing block of the breaker arm is at high point of the cam. Make sure the screws are loose enough to allow adjustment.

Insert adjusting blade of the distributor adjusting wrench, No. 12150-A, in the adjustment opening and turn in the proper direction to obtain an air gap of .024" to .026". Use a round wire gauge to check the air gap, as roughness of points makes it impossible to obtain a true setting when using a flat gauge.

CAUTION: Be sure to wipe the gauge with a clean cloth before inserting it between the points.

After screws are tightened, recheck the air gap.

The breaker arm tension should also be checked when replacing new points. Improper breaker arm spring tension will cause the moving breaker point to bounce and results in erratic spark control, which commonly causes the engine to misfire at high speeds. Breaker arm tension is 17 to 20 ounces, measured from the inner edge of point contact surface and at right angles to same.

IGNITION COMPLAINTS

If excessive point pitting exists, check for correct contact spacing, .024" to .026". Check all of the connections for tightness. Test the condenser on a condenser tester. Check the condenser lead for frayed strands.

Never use an emery cloth to dress contact points. Use a stone made especially for this purpose. After stoning, the points and distributor cam must be thoroughly cleaned with carbon tetrachloride or ether, and the cam must be lubricated as suggested on following page.

Contacts must be set properly. Points set too closely, burn and pit rapidly. Points with too wide a gap cause weak spark at high engine R. P. M.

Do not use a feeler gauge on points that have been in use, since roughness of points makes it impossible to set the air gap correctly. Use a dial indicator or point wire gauge instead of the thickness gauge.

Oxidized points may be caused by high resistance or loose

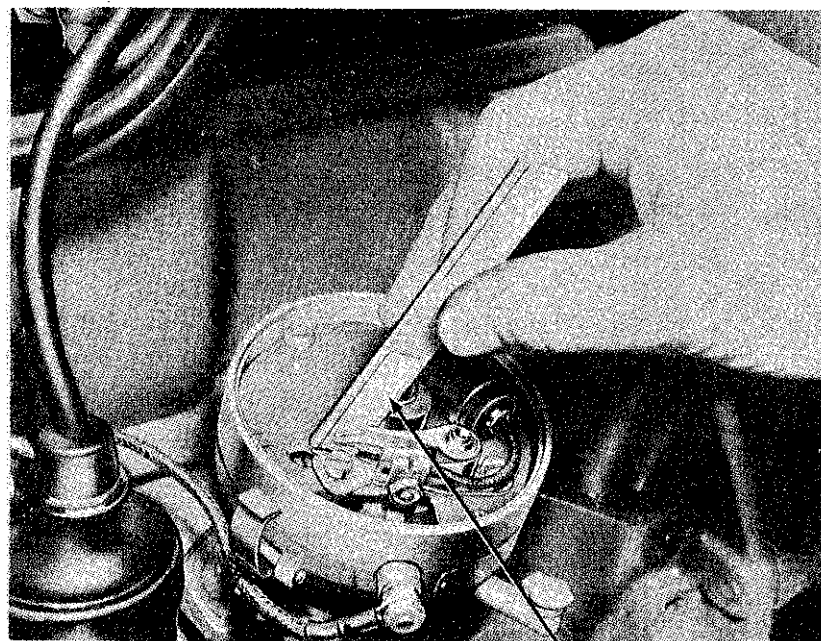

CONTACT POINT STONE

Figure 23 Stoning Distributor Contact Points to Remove Small Pits

connections in the condenser circuit, or oil on the contact surfaces. Replace the distributor cap and rotor if they show evidence of carbonized paths.

Clean and lubricate the cam with a light film of Ford M-4601-A lubricant in accordance with instructions in the lubrication chart. Do not over lubricate, because oil reaching the contact points causes rapid burning of the points.

BATTERY

The battery is an electro-chemical device used to convert chemical energy into electrical energy. Its primary function is to store energy for starting the engine. After the engine starts, the generator supplies electrical current for the system.

CHECKING BATTERY ELECTROLYTE

At least once each week cover the cells up to the ring with distilled water or clean rain water. This is best done with a syringe. The specific gravity indicates state of battery charge, and is measured with a hydrometer. Reading directions are supplied by the hydrometer manufacturer. Rapid loss of the battery water is an indication of an overcharged battery and its cause should be

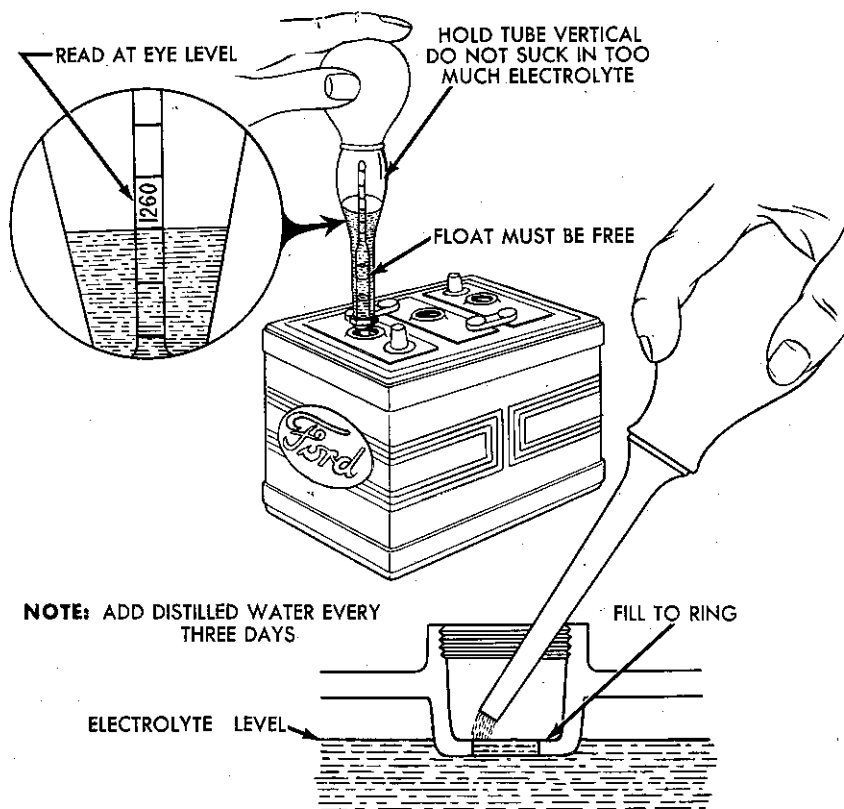

Figure 24 Checking Battery Electrolyte

corrected. A difference in reading of 20% to 25% between cells also indicates battery trouble. The temperature at which a battery will freeze depends on its state of charge and specific gravity. Keep the battery fully charged at all times.

State of Charge	Specific Gravity Temperate Climates	Specific Gravity Tropical Climates
Fully Charged	1, 280	1, 225
75%	1, 230	1, 180
50%	1, 180	1, 135
25%	1, 130	1, 090
Discharged	1, 080	1, 040

Figure 25 Battery State of Charge Chart

A battery that is used in a tropical climate, where freezing rarely occurs, is provided with a milder strength acid, which gives it a different specific gravity value than that used in cold climates. This is shown in the right column of Fig. 25 on Page 34.

BATTERY SERVICE

Battery terminals should be tight and kept free of corrosion. Two tablespoons of baking soda mixed with a pint of water, makes a satisfactory solution for cleaning corroded terminals and battery case. This solution is best applied with a paint brush. After cleaning, the soda water must be washed off with clean water. Apply petroleum jelly to the terminals to counteract corrosion.

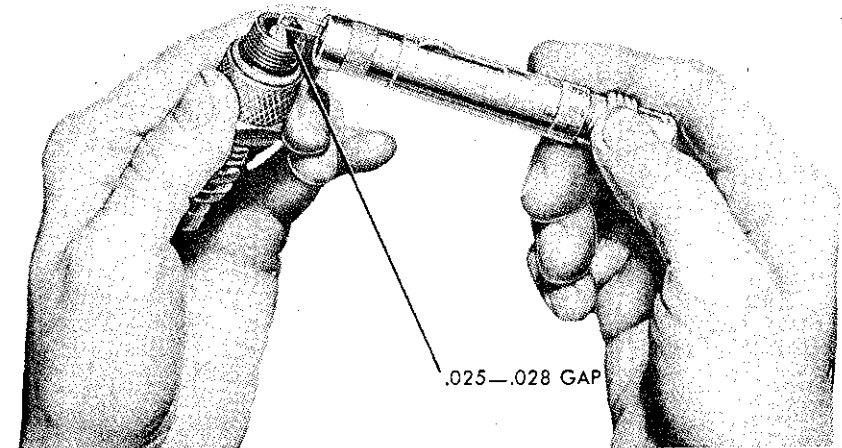

Figure 26 Adjusting Spark Plug Gap

SPARK PLUGS

Under normal operating conditions, the spark plugs should be removed, cleaned, and inspected every 200 hours.

Spark plugs may become fouled with carbon by leaky or stuck valves, overrich carburetion, gaps that are set too close, or oil in the combustion chamber due to worn cylinders and valve guides.

Spark plugs should be cleaned and tested with equipment made especially for this purpose. Some spark plugs may appear to be serviceable yet leak under compression pressure. This causes the plug to overheat and also results in loss of engine power. Discard plugs with badly pitted or cracked insulators. Spark plug wires can be kept free of oil and dirt by occasionally wiping them with a clean cloth. pp 37.

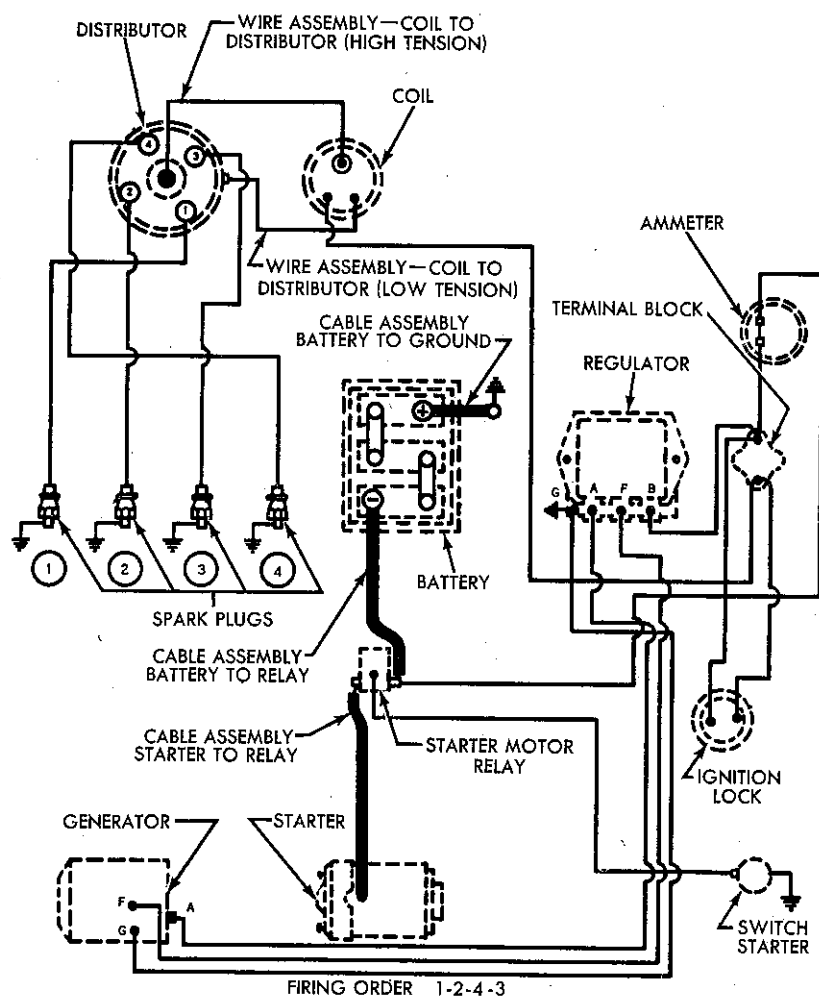

KEY

CIRCUITS	WIRE NO.	COLOR
IGNITION LOCK TO IGNITION COIL	16	Red—Green Tracer
WIRING JUNCTION BLOCK TO IGNITION LOCK	21	Yellow
GENERATOR GROUND TO REGULATOR	26	Black—Red Tracer
STARTER SOLENOID TO STARTER SWITCH	32	Red—Blue Tracer
GENERATOR FIELD TO REGULATOR	35	Black—White Tracer
GENERATOR ARMATURE TO REGULATOR	36	Yellow—Black Tracer
REGULATOR TO WIRING JUNCTION BLOCK	37	Yellow
STARTER SOLENOID TO WIRING JUNCTION BLOCK	38	Yellow

Figure 27 Wiring Diagram

Always use a round wire gauge to check the air gap, as a feeler gauge will not measure the depression generally burned in the electrodes. Correct air gap is .025 to .029".

H-10 heat range plugs, or equivalent, are engineered to give the best operating results and should always be used when installing new plugs. Size of the spark plug is 14 mm. Tighten plugs with a torque wrench 25 to 30 ft. lbs.

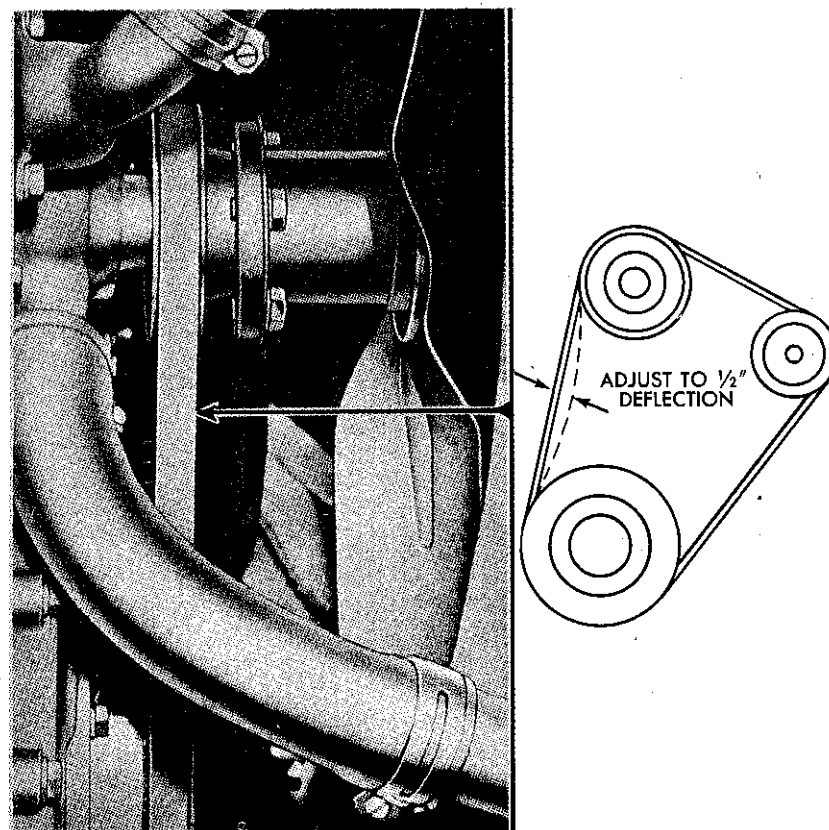

Figure 28 Adjusting Fan and Generator Belt Tension

FAN AND GENERATOR BELT ADJUSTMENT

Loosen the two generator pivot bolts located at the base of the generator and the belt tension adjusting bolt nut. Move the generator away from the engine until a 1/2" belt deflection is obtained as shown in foregoing Fig. 28. Overtightening the belt

may cause premature wear of the generator armature shaft bearings, whereas too loose an adjustment may result in belt slippage and an overheated engine.

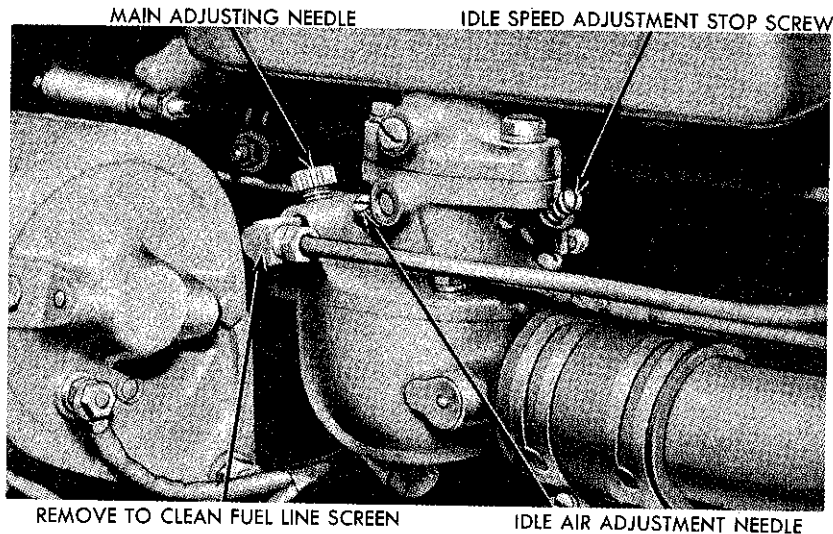

Figure 29 Carburetor Adjustments

CARBURETOR ADJUSTMENT

Three adjustments on the carburetor are necessary. These are the main adjustment needles, idle speed adjustment stop screw and idle adjustment needle, Fig. 29. Before attempting to adjust the carburetor, the engine must always be at normal operating temperature. With the hand throttle in closed position, set the engine idle speed (450-500 R. P. M.). On a new engine not yet broken in, idle speed may have to be set slightly higher so that the engine does not stall. The idle speed adjustment stop screw is located on the engine side of the carburetor. For the initial setting before the engine is started, turn the idle adjustment needle in (clockwise) until it just seats, then back it off approximately one turn.

Start the engine and turn the idle adjustment needle in (clockwise) until the engine begins to roll from too rich a mixture, then back the needle off until the engine runs smoothly.

The initial setting for the main adjusting needle (Fig. 29) is 1-1/4 turns open (counterclockwise). The final adjustment is best made under load. With the engine running at governed speed under full load, turn the adjustment needle in (clockwise) until the engine power just begins to drop off, then turn the screw out (counter-

clockwise) until the power picks up and the engine runs smoothly.

POWER TAKE-OFF DISASSEMBLY

Remove pulley, sprocket, or other driving means from output shaft.

If bellhousing flange fits tightly in bore of flywheel housing, remove by turning cap screws into two holes in flange.

NOTE: Be sure that weight of power take-off assembly is not permitted to hang on pilot bearing end of drive shaft. Move complete assembly straight back until end of drive shaft clears pilot bearing.

Insert pry-bars on opposite sides of clutch across bellhousing flange and exert pressure on back of pressure plate.

Using babbitt hammer or wood block, hit pilot end of shaft sharply to loosen the taper drive fit between clutch body and shaft, permitting removal of entire clutch with key.

Mark both halves of bronze release bearing so they will be reassembled in the same relative position.

CAUTION: Do not hit shaft with undue force, or damage to tapered roller bearings may result. Be sure to protect shaft end while tapping, to prevent damage to pilot bearing diameter.

INSPECTION

Carefully clean all parts in suitable solvent before inspection.

Inspect friction surfaces on clutch body and pressure plate for cracks, heat-checks, warpage, and facing for wear.

Check return springs for loss of spring pressure, 19 to 23 lbs. at 1-1/16" for 10" clutches.

Check adjusting nut for wear on front face, which is contacted by levers.

IMPORTANT: Adjusting lock plate must be held tightly by spring washer. If lock plate is not held tightly, clutch adjustment will not be maintained and constant clutch trouble will be experienced.

ASSEMBLY (P.T.O.)

Place pressure plate over hub with flat surface down.

Place return springs in recesses in clutch body.

Place pressure plate face down (protect surface) on bench preparatory to assembling levers.

Lay lever springs in position between bosses on pressure plate with open ends resting on outer rim of pressure plate.

Hold lever horizontal with machined portion down and slide between bosses on pressure plate.

Place small end of lever under closed end of lever spring and line up lever pin holes with holes in pressure plate bosses by raising small end of levers against spring tension.

Insert lever pin and secure retaining ring into groove in end of lever pin.

NOTE: Machined portion of lever must be toward center of clutch.

Using heavy gauge wire, make a hook for each lever. Pass through hole on small end of lever and under rim of pressure plate, to hold levers in an upright position against tension of springs. This is to provide clearance for assembling adjusting nut.

Place pressure plate, with levers and springs assembled, over hub of clutch body, so splines on inside of pressure plate mesh with splines of clutch body, and face of pressure plate rests on four return springs.

If replacing adjusting lock plate, use new stud and spring washer. Pressure must be exerted on head of stud to compress friction washer until shoulder of stud is firm against counterbore in adjusting nut. Thenpeen opposite end of stud, which extends through adjusting nut counterbore on machined side.

NOTE: If arbor press is not available, it is recommended that you order a complete new adjusting nut, as it is imperative that the adjusting lock plate be held with sufficient pressure to maintain adjustment of the clutch.

Turn adjusting nut onto hub of clutch body flush with face of hub. Remove wire hooks holding levers.

Observing assembly marks made at time of disassembly, assemble two halves of bronze release bearing over shoulder on release sleeve and secure with two cap screws and nuts.

Assemble triangular end of links toward large diameter of re-

lease sleeve by inserting pins through holes in bosses on sleeve and link. Secure pins with retaining rings.

CAUTION: Make sure retaining ring is secure in groove of lever pin by gripping O. D. with pliers.

Release sleeve assembly can now be placed on clutch so ends of links straddle ends of levers. Connect links and levers by pins, and secure pins with retaining rings. Observe caution as in previous pin assemblies.

Insert three facing sections between friction surfaces of clutch body and pressure plate.

Place drive ring over facing sections, making sure drive ring is centrally located in relation to pressure plate by measuring carefully from outside diameter of pressure plate.

Adjust clutch when assembling as follows:

To adjust clutch, apply sufficient pressure on release bearing for sleeve to contact adjusting nut.

Turn adjusting nut clockwise until pressure plate just contacts facing sections, then release clutch.

Turn adjusting nut clockwise ten notches.

NOTE: This is especially important, as it will be impossible to assemble the unit in the flywheel unless teeth on facing sections are centrally located in relation to power take-off shaft.

Lock facing sections in position by engaging clutch. Considerable pressure will be required to engage clutch, making it necessary to use an arbor press, jack, or similar equipment.

Remove drive ring and bolt ring to flywheel.

Press tapered roller bearings on drive shaft. One from pilot end and one from opposite end, with large end of bearing cones firmly against shoulder. Lubricate roller bearings liberally with a good quality, medium weight, clean bearing grease. Cover the roller well and fill space between bearings.

Install cup of roller bearing in hub of housing with large end of cup inserted first and seat firmly. Fill grooves in hub of housing with lubricant.

With housing resting on hub end, install shaft with bearings assembled by passing output end through bore in hub.

Place cup of inner roller bearing, with small end down, firmly against rollers, and turn bearing retainer into threaded hole of housing. Rotate shaft and tighten bearing retainer firmly against bearing to positively seat cones in position and shaft becomes difficult to rotate.

To provide proper clearance for roller bearings to operate, turn the bearing retainer back three notches and lock in place by means of lock plate, washer, and screw. Using a babbitt hammer or block of wood, tap output end of shaft lightly to free roller bearings to allow proper operating clearance.

Assemble yoke shaft into bore of bell housing and through yoke just starting into opposite hole in housing. Note that yoke is assembled to yoke shaft with heads of screws toward open end of housing.

Move yoke over to side of housing until keyways in yoke shaft are visible and insert keys in yoke shaft.

Slide yoke over keys until it is located in the housing and yoke shaft extends an equal distance outside of housing and tighten screws securely.

Set housing and shaft assembly with pilot end up and securely support on blocks. This will place weight of the assembly on housing and prevent possibility of damage to shaft and bearing.

Start clutch assembly over pilot end of shaft, lining up keyway in body with keyway in shaft. Assemble clutch, guiding trunnions on bearing into yoke ends.

When taper on shaft mates with taper of body, insert key and tap into place.

Place tab washer over pilot end of shaft, making sure that tab fits into keyway of body. Install nut, tighten securely, then bend one tab of washer against flat side of nut to lock.

Assemble shifting lever to yoke shaft. Lock in place by screw and washer.

Assemble power take-off to engine by positioning pilot end of shaft into pilot bearing. Mesh teeth in facing section with teeth in drive ring bolted to flywheel.

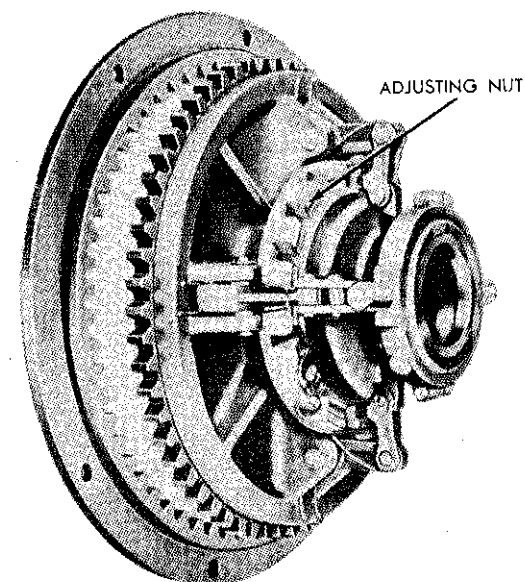

Figure 30 Power Take-Off Clutch

POWER TAKE-OFF CLUTCH ADJUSTMENT

Power take-off is the over-center clutch type, designed to fit standard S. A. E. No. 4 flywheel housing.

Clutch is the heavy-duty, gear-tooth drive, single-plate type with clutch facing member in three sections. To adjust the clutch, place it in released position, then remove the cover. Insert end of long screwdriver into notch of adjusting nut (painted red), Fig. 30. Turn the nut clockwise by prying against edge of handhole in housing to tighten adjustment, as sufficient pressure on shifting handle is applied to keep clutch from turning while making adjustment. Excessive pressure will make it difficult to turn adjusting nut.

Keep turning the adjusting nut clockwise until pressure required on shifting handle to engage clutch is approximately 105 lbs., measured at small finger position on shifter with a fish scale. If fish scale is not available, tighten adjusting nut until clutch engagement is no longer possible by exerting pressure on shifting handle then back up the equivalent of two notches. Adjusting plate automatically locks adjusting nut in position after adjustment.

CAUTION: Most clutch failures are caused by a slipping

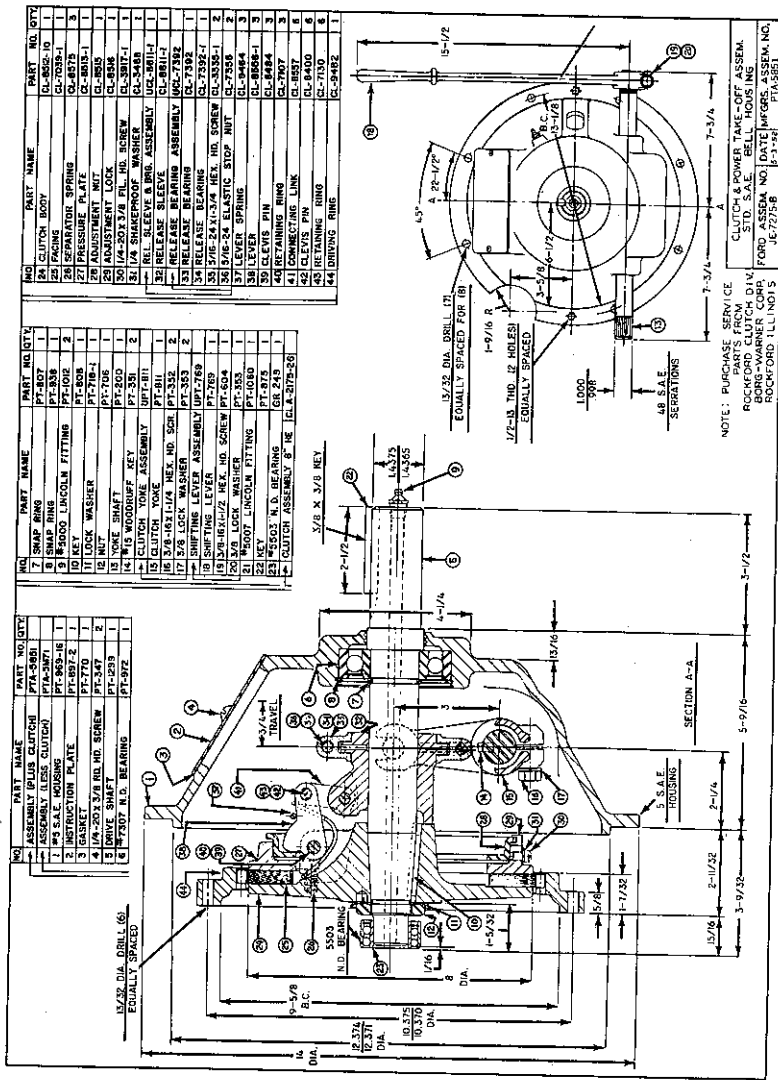

Figure 31 Rockford Clutch Details

clutch. Daily checks and adjustment, if necessary, should become habitual with your power unit operator to eliminate failures from this source.

ENGINE SPEED CONTROL GOVERNOR

The governor used on the Model E and D power units is a centrifugal, variable speed control type, mounted on the front of the engine crankshaft directly behind the crankshaft pulley.

Moving the carburetor hand throttle to the lower position opens the carburetor throttle valve and also applies tension on throttle rod spring attached to governor speed control lever. Governor action is controlled by six steel balls sandwiched between a concave and a flat race, located inside the governor housing shown in Fig. 32.

As engine speed increases, centrifugal force moves these balls toward the perimeter of the races. This action forces the concave race to move away from the flat race which, in turn, moves the fork and attached governor arm toward the closed carburetor throttle position until a balance between spring tension and governor action causes engine speed to remain constant.

Maximum engine speed is controlled by the adjustable stop on the throttle rod shown in Fig. 32.

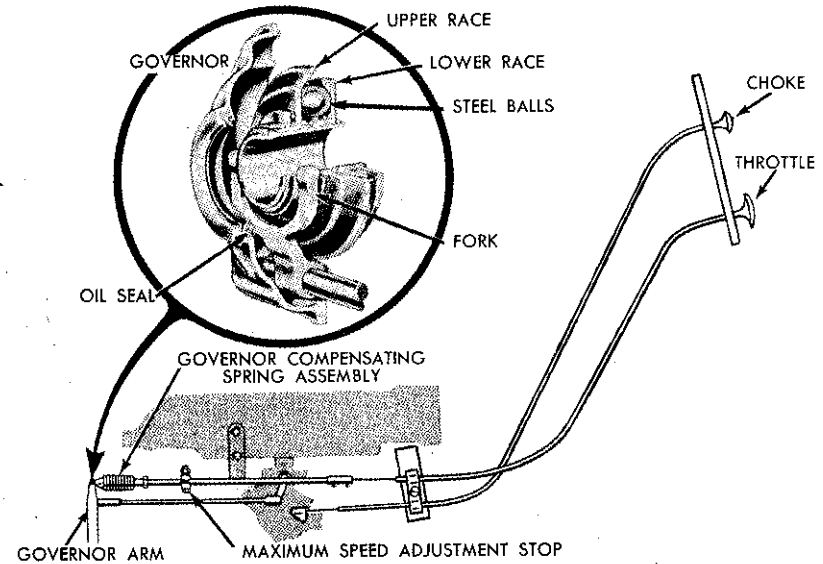

Figure 32 Governor and Throttle Control Linkage

SETTING GOVERNOR ENGINE SPEED

Before attempting to set the engine governed speed, make certain the governor lever and carburetor throttle lever are both in full open position. This can be checked by removing the throttle rod at the carburetor and holding the throttle lever in open position, as pulling force is applied to the throttle rod connected to the governor speed control arm. If the throttle rod connector will not slip over the ball on the carburetor throttle valve arm without moving the arm, the linkage must be adjusted to obtain idle speed of 450 to 500 engine revolutions per minute.

To set the recommended maximum speed of 2400 revolutions per minute, first loosen the governor speed stop nut, Fig. 32. Then open the hand throttle until the tachometer registers 2400 revolutions per minute. Secure the maximum speed stop against the throttle rod stop guide bracket by tightening the lock nut.

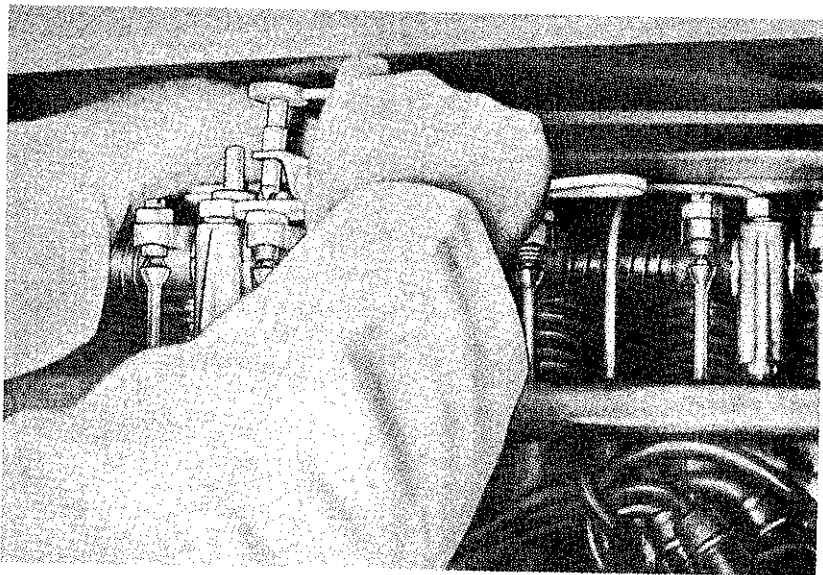

Figure 33 Adjusting Valve Stem
(Adjusting Tappets) To Rocker Arm Clearance

VALVE TAPPET ADJUSTMENT

One of the factors governing good engine performance is correct valve operation, and this cannot be obtained unless correct valve tappet clearances are maintained. When tappet clearances are insufficient, valves cannot close on their seat and valves that do not seat properly will soon burn through at the edges. Too

little clearance is also a contributing factor in valve warpage. When tappet clearances are too great, the valves open late and close early. When this condition exists, a portion of the cam ramp is not in use and the valves open and close with terrific impact, thus causing abnormal stress on the valve train which greatly increases the possibility of valve breakage, particularly at high engine speeds. This also reduces the efficiency of your engine because the valves are not open long enough to get sufficient fuel into the combustion chamber or to exhaust all of the burned gases.

On a new industrial engine, correct clearances are established before your engine leaves the factory. So that you may obtain the maximum performance your engine was designed for, we recommend having valve tappet clearances checked at least twice yearly or more often if they become excessively noisy. Before attempting to set valve tappet clearances, run the engine until it reaches normal operating temperature. After normal temperature is reached, stop the engine and shut off the fuel supply at the fuel bowl. It is necessary to remove the glass bowl before the rocker shaft cover can be removed.

Before setting valve tappet clearances, turn the engine over until the piston is at the top of the compression stroke. This can be determined by disconnecting all the spark plug wires from the plugs, then turning the ignition key on and holding the spark plug wire terminal about 1/16" away from the engine block as the engine is cranked by hand. The instant spark occurs, the piston has reached the top of the compression stroke and has just fired. Both valves are now in closed position for tappet adjustment. An alternate method of determining when the piston is at the top of the compression stroke, is to remove the spark plug and hold a finger over the hole until compression is felt. Before adjusting valves, set the ignition timing and adjust the contact point air gap. Also examine the rocker arm tips for excessive wear. A worn rocker arm tip will have a depression which makes it impossible to obtain an accurate setting, therefore, the rocker arm must be replaced. Adjust tappets in their respective firing order of 1-2-4-3. Never attempt to turn the adjusting screw until the lock nut has been loosened, and always make certain the lock nut is secure after adjustment. The combination adjustment tool used in Fig. 33 on Page 46, simplifies this adjustment and is obtainable from your dealer. The correct valve tappet clearance is .014 to .016".

VALVE GRINDING

One of the factors involving good engine performance is absolute sealing of the combustion chamber by the valves and rings against compression losses. Valves and valve seats of modern engines are so hard that it is impossible to obtain a satisfactory

valve reconditioning job by the outmoded method of hand grinding.

This job takes modern high-speed grinding equipment in the hands of a skilled technician. If hand grinding is attempted and the valve does not seat 100% after grinding, even a small leak will eventually cause valve failure. The action of the exhaust gases leaking past the valve is like that of a cutting torch flame, which will cause the metal to soon burn away. A good valve job is so important to good engine performance that we recommend having your dealer perform this work whenever it becomes necessary.

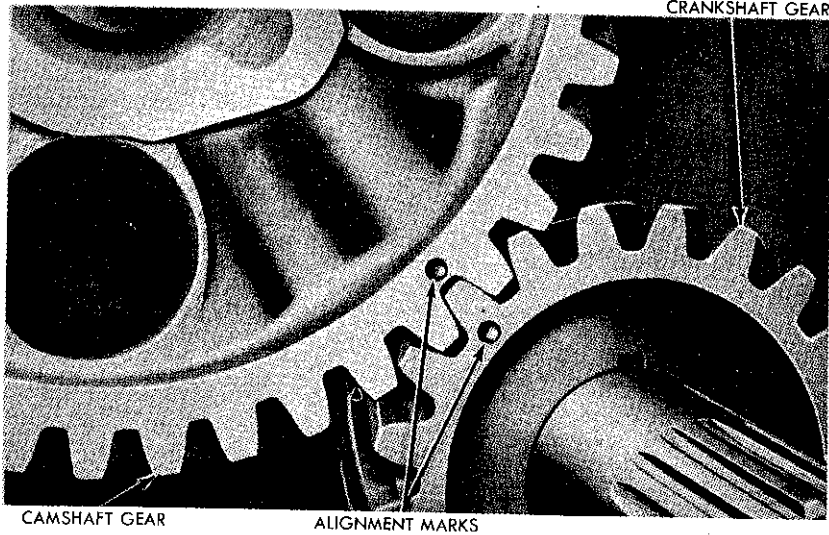

Figure 34 Valve Timing

VALVE TIMING

The camshaft of your industrial engine is timed to the crankshaft by aligning the camshaft gear marks with the mark on the crankshaft as shown in Fig. 34.

TIGHTENING CYLINDER HEAD CAP SCREWS

Even tightening the cylinder head is very important so that an air tight seal is obtained between the water passages in the cylinder head and block. To provide a uniform seal, a torque indicating wrench must be used. Using an ordinary hand wrench for this purpose will result in overtightening of some cap screws and undertightening of others. Overtightening may cause distortion of the cylinder head and bores, and undertightening may result in a blown or leaky cylinder head gasket. Tighten cap screws to specified

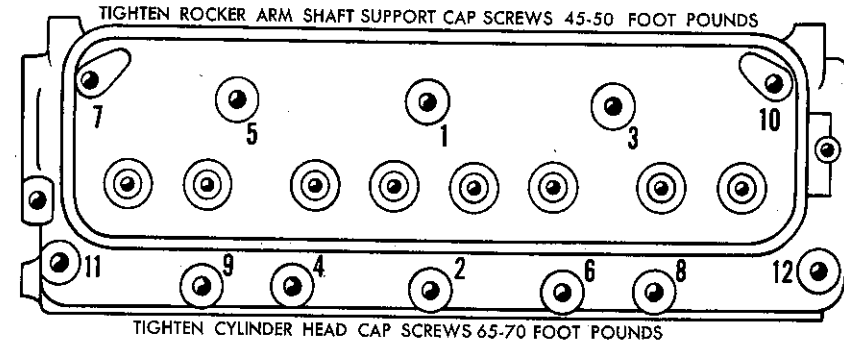

Figure 35 Cylinder Head Tightening Sequence

torque shown in Fig. 35 before starting your engine and also after your engine has been warmed up to normal operating temperature.

NOTES

MODELS E AND D POWER UNIT SERVICE OPERATIONAL COMPLAINTS AND CORRECTIONS

Symptom	Possible Cause	Check	Remedy
Starter will not crank engine.	Discharged battery.	Hydrometer test.	Recharge or replace battery.
	Corroded terminals.	Battery terminals.	Clean and tighten terminals.
	Loose connections.	Cable connections.	Tighten connections.
	Defective starter relay.	Start relay operation.	Clean contacts if necessary.
		Short across large terminals of switch.	Replace switch.
Engine cranks too slowly.	Too heavy oil in crankcase.	Inspect oil.	Drain, refill with lighter oil.
	Weak battery.	Hydrometer test.	Recharge or replace battery.
	Corroded terminals.	Battery terminals.	Clean and tighten terminals.
	Defective cable.	Battery cables.	Install new cable.
Engine is cranked by starter but will not start.	Battery too weak to supply ignition while cranking.	Hydrometer test.	Recharge or replace battery.
		Faulty ignition.	Spark plugs.
		Breaker contacts.	Resurface or replace contacts and adjust gap.
		Coil, cables, condenser.	Replace defective parts.
	Corroded start relay contacts.	Short across terminals.	Clean the relay contacts, or replace if necessary.
	Lack of fuel or faulty carburetion.	Fuel tank empty.	Refill.
		Clogged fuel line.	Clean.
		Fuel bowl screen.	Clean.
		Fuel pump.	Clean, repair or replace.

Symptom	Possible Cause	Check	Remedy
Engine is cranked by starter but will not start.		Choke stuck	Replace, if defective.
		Cylinders flooded.	Crank few times with throttle wide open, ignition off.
		Poor fuel.	Drain, refill with good fuel.
		Dirt in carburetor	Clean.
	Poor compression, usually because of leaking valves.	Take compression with compression gauge.	Tighten or replace head gasket. Tighten spark plugs. Adjust tappets.
	Wrong timing.	Spark timing.	Retime.
Engine runs but voltage does not build up.	Poor brush contact	Brushes and commutator.	See that brushes seat well on commutator, are free in holders, are not worn shorter than 1/2" and have good spring tension. If commutator is rough or badly grooved, repair.
		Open circuit, short circuit or ground in generator.	No simple test. Repair.
	Poor seating of brushes.	Brushes.	Refer to above.
Voltage unsteady but engine not missing.	Worn commutator or poor brush contact.	Commutator and brushes.	See that brushes seat well on commutator, are free in holders, are not worn shorter than 1/2" and have good spring tension. If commutator is rough or badly grooved, tighten connections.
		Loose connections	Connections
	Fluctuating load.	Check load.	Some abnormal load condition causing trouble.
	Fluctuating loads such as a motor driving a single action reciprocating pump, are	Correct any abnormal load condition causing trouble.	

Symptom	Possible Cause	Check	Remedy
Voltage etc. cont'd.		normal conditions.	
Generator overheating.	Overloaded.	Ammeter.	Reduce load.
Voltage drops under heavy load.	Engine lacks power	See symptom of engine missing under heavy load. Crank with ignition off, noting whether compression uniformly good on all cylinders. Carburetor. Carburetor air cleaner. Choke. Carbon in cylinders. Restricted exhaust line.	See remedies for engine missing under heavy load. Tighten or replace head gasket, Tighten spark plugs. Adjust tappets. If still not corrected, repair unit. Clean carburetor. Clean air cleaner. See that it opens wide. Remove carbon. Clean.
Engine misses at light load.	Carburetor idle adjustment set wrong or clogged. Spark plug gaps too narrow. Intake air leak. Faulty ignition. Uneven compression.	Carburetor. Spark plugs. Intake manifold. Breaker and coil. Crank with ignition off noting whether compression uniformly good on all cylinders.	Adjust, clean if needed. Set at .025" to .028". Tighten or replace gaskets. Adjust or replace. Tighten head gasket and spark plugs. Adjust tappets.
Engine misses at heavy load.	Spark plugs defective. Faulty ignition. Clogged carburetor jets.	Spark plugs. Breaker, coil and condenser. Carburetor.	Replace. Adjust or replace. Clean.

Symptom	Possible Cause	Check	Remedy
Engine misses at heavy load.	Clogged fuel screen. Tappets adjusted too close. Defective high tension cables.	Fuel screen. Tappets. High tension cables.	Clean. Adjust. Replace.
Engine misses at all speeds.	Fouled spark plug. Defective or wrong spark plug. Sticking valves. Broken valve spring. Defective ignition wires. Pitted or improperly adjusted breaker contacts. Defective ignition condenser. Tappets need adjusting.	Spark plugs. Spark plugs. Valves. Valve springs. Ignition wiring. Breaker contacts. See if breaker contacts are sooty and spark weak and yellow. Tappets.	Clean and adjust. Replace. Repair. Replace. Replace. Adjust or replace. If so, replace condenser. Adjust.
Low oil pressure.	Oil too light. Oil badly diluted. Oil too low. Oil relief valve not seating. Badly worn engine bearings. Sludge on oil screen. Badly worn oil pump. Defective oil gauge.	Inspect oil. Inspect oil. Oil level. Oil relief valve. Smoky exhaust, excessive oil consumption which cannot otherwise be accounted for. Must remove pan to check. No simple check. No simple check.	Drain, refill with proper oil. Drain, refill with proper oil. Add oil. Remove and clean. Repair. Clean screen. Replace unit. Replace unit.
High oil pressure.	Oil too heavy.	Inspect oil.	Drain, refill with proper oil.

Symptom	Possible Cause	Check	Remedy
High oil pressure.	Clogged oil passage.	No simple test.	Repair.
	Oil relief valve stuck.	Oil relief valve.	Remove and clean.
	Defective oil pressure gauge.	Should read zero when unit not operating.	If not, install new oil pressure gauge.
Engine stops unexpectedly.	Fuel tank empty.		Refill.
	Water temperature high.	Water in radiator.	Add water.
		Air flow through radiator.	Clean radiator fins.
		Unit overloaded.	Reduce load.
		Ventilation.	Increase ventilation.
		Fan belt.	Tighten, or install new one.
	Water not circulating freely due to deposit build up or defective hose.	Drain, flush and refill radiator, replace defective hose.	
	Low oil pressure usually due to lack of oil.	Oil level dip stick.	Add oil to crankcase.
Engine backfires at carburetor.	Lean fuel mixture.	Carburetor.	Clean carburetor.
	Poor fuel.	Fuel screens. Fuel.	Replace gaskets. Drain, fill with good fuel.
	Spark too late.	Crankshaft pulley mark.	Retime ignition.
	Distributor wires crossed.	Distributor wires.	Install wires correctly.
	Intake valves leaking.	Hiss through carburetor when cranked with ignition off.	Adjust tappets. If this does not correct, repair.
Excessive oil consumption, light blue	Sludged rings, excessive bearing clearances, piston skirt col-	Compression with ignition off, with wide open throttle.	Tighten or replace head gasket. Tighten spark plugs. Adjust tappets.

Symptom	Possible Cause	Check	Remedy
(Symptom cont'd) smoky exhaust.	lapsed, worn intake valve guides.	Compression must be uniformly good on all cylinders.	
	Oil leaks from oil pan or connections. This does not cause smoky exhaust.	Inspect visually for leaks.	Replace gaskets. Tighten screws and connections.
	Oil too light or diluted.	Inspect oil.	Drain, refill with correct oil.
	Bearing clearance too great.	Oil pressure gauge registers low and this cannot otherwise be accounted for.	Repair.
	Oil pressure too high.	Oil pressure gauge.	Refer to symptom of high oil pressure for remedies.
	Engine misses firing.	Voltmeter reading unsteady and exhaust irregular.	Refer to symptom of engine misses.
Faulty ignition.		Spark plugs.	Clean, adjust or replace.
		Breaker contacts.	Resurface or replace contacts and adjust gap.
		Coils, cables, condenser.	Replace defective parts.
	Unit operated a great deal at light or no load.	Operating conditions.	No remedy needed.
	Too much oil.	Dip stick.	Drain excess oil.
Black, smoky exhaust, excessive fuel consumption, fouling of spark plugs with black soot, possible lack of power under heavy load.	Fuel mixture too rich.	Carburetor float for leak and high level, needle valve for leak, jets for wear or damage, gasket washers for leaks.	Install needed carburetor parts, adjust float level. Be sure all jet gaskets are in place and tight, and needle valve gasket is in place and tight.

Symptom	Possible Cause	Check	Remedy
Black, smoky exhaust, etc. cont'd.	Choke not open.	Choke.	See that choke opens properly.
	Dirty carburetor air cleaner.	Air cleaner.	Clean, refill to proper oil level.
Light pounding knock.	Loose connecting rod bearing.	Short out one spark plug at a time to locate.	Repair unit.
	Low oil supply.	Dip stick.	Add oil.
	Low oil pressure.	Oil pressure gauge.	Refer to symptom of low oil pressure for remedies.
	Oil badly diluted.	Inspect oil.	Change oil.
Dull metallic thud, if not real bad may disappear after few minutes operation. If bad, increases with load.	Loose crankshaft bearing.	Accelerate under load.	Repair unit.
Sharp metallic thud, especially when cold plant first started.	Low oil supply.	Dip stick.	Add oil.
	Low oil pressure.	Oil pressure gauge.	Refer to symptom of low pressure for remedies.
	Oil badly diluted.	Inspect oil.	Change oil.
Pinging sound when engine is rapidly accelerated or heavily loaded.	Carbon in cylinders.	Crankshaft	Remove carbon.
	Spark too early.	Pulley	Retime ignition.
	Wrong spark plugs.	Spark plugs.	Install J-9 plugs.
	Spark plugs burned or carboned.	Spark plugs.	Install new plugs.
	Valves hot.	Tappet clearance.	Adjust tappets.
	Fuel of low octane.	Fuel.	Use seasonal fuel.
	Lean fuel mixture.	Carburetor.	Clean.
Clicking sound.	Tappet clearance too great.	Tappet clearance.	Adjust tappets.
	Broken valve spring.	Valve springs.	Install new spring.

Symptom	Possible Cause	Check	Remedy
Hollow clicking sound with cool engine under load.	Loose pistons.	Put tablespoonful heavy oil in cylinder suspected. Crank engine with ignition off to lubricate piston. Then start engine. If noise not present, indicates loose piston or piston rings.	If noise only slight and disappears when engine warms up, no immediate attention needed.

NOTES

NOTES

STORAGE AND SPECIFICATIONS

STORAGE—ONE MONTH

1. While engine is running, treat upper cylinders by spraying M-4834-A, Engine Preservative Oil (S. A. E. 10), or equivalent into carburetor air intake for about two minutes. Open throttle for short burst of speed, shut off ignition and allow engine to come to a stop while continuing to spray M-4834-A into air intake.

2. Leave spark plugs in holes or seal spark plug holes with suitable threaded metal plugs and cover all openings into engine with dust-proof caps or shields.

3. Drain oil, water, and gasoline.

4. If engine is less transmission, spray flywheel and ring gear with mixture of one part M-4850, Bodies Anti-Rust Oil, and one part M-4970, Stoddard Solvent, or equivalents.

STORAGE—FOR INDEFINITE PERIOD

1. Drain crankcase completely and refill with M-4834-A, Engine Preservative Oil (S. A. E. 10), or equivalent.

2. Run engine until completely out of gasoline, then restart and run on M-534-H or equivalent unleaded, undyed gasoline for at least 10 minutes.

3. While engine is still running and at completion of above run, treat upper cylinders by spraying M-4834-A into carburetor air intake for about two minutes. Open throttle for short burst of speed, shut off ignition and allow engine to come to a stop while continuing to spray M-4834-A into air intake.

4. Drain oil and gasoline. Drain water at the bottom of radiator and also left rear side of cylinder block.

5. Remove grease and oil from exterior surface of engine.

6. Leave spark plugs in holes or seal spark plug holes with suitable threaded metal plugs.

7. Seal all openings in engine and accessories with M-6471, Non-hydroscopic Adhesive Tape, or equivalent. Mask off all areas to be used for electrical contact.

8. Make sure all surfaces are dry, then spray all taped openings, all engine accessories including ignition wiring, and all

exterior surfaces of engine with M-4858-B, Insulation Compound, or equivalent.

9. If engines are equipped with automotive type clutch, block clutch in slightly disengaged position so that lining and pressure plate are not in contact.

CAUTION: Do not completely depress clutch lever.

GENERAL SPECIFICATIONS

Most of the specifications on models E and D industrial power units are identical. Specifications that differ are designated by model number.

<u>CAPACITIES - U. S. Measure</u>	<u>Model</u>	
Fuel Tank	E- D	11 gal. total (1-3/4 gal. reserve)
Engine Oil Pan (less filter absorption)	E- D	4 qts. Refill 5 qts. if filter is replaced.
Cooling System	E- D	15 qts.
Oil Bath Air Cleaner	E- D	1.3 pints

ENGINE

Type	E- D	4 cylinder, in-line, overhead valve.
Idle Speed	E- D	450-500 R. P. M.
Cylinder Bore	E	3.4375 in.
" "	D	3.9 in.
Stroke	E- D	3.60 in.
Piston Displacement	E	134 cu. in.
" "	D	172 Cu. In.
Torque at 1400 R. P. M. } Without accessories }	E	110 lbs. ft.
	D	146 lbs. ft.
Compression Ratio	E	7.5 to 1
" "	D	7.5 to 1
Sleeves	E- D	Centrifugally cast alloy iron, dry type.
Piston	E- D	Autothermic, cam ground, aluminum alloy.
Rings:		
Compression	E- D	2 - cast iron - top, chrome plated.
Oil	E- D	1 - cast iron.
Piston Pins	E- D	Floating

<u>ENGINE (Cont'd)</u>	<u>Model</u>	
Rod Bearings	E- D	Replaceable steel backed inserts.
Main Bearings	E- D	Replaceable steel backed inserts.
Crankshaft	E- D	Precision moulded alloy iron, statically and dynamically bal- anced.
Coolant Flow	E- D	20 gal. per minute at 170° F. at 2000 R.P.M.
Fan:		
Type	E- D	4 blade unequal spac- ing pull.
Drive	E- D	V-belt drives water pump and generator.
Thermostat:		
Location	E- D	Engine water outlet.
Starts to Open	E- D	157 - 162° F.
Fully Open	E- D	177 - 182° F.

ELECTRICAL SYSTEM

Generator:		
Type	E- D	2 brush shunt.
Drive	E- D	V-belt.
Rating:		
1650 R. P. M. (hot)	E- D	20 amps.
Maximum Output	E- D	20 amps.
Capacity	E- D	160 watts.
Generator Regulator:		
Cutout Closing Voltage	E- D	6.0 - 6.6 volts.
Cutout Opening Voltage	E- D	0.5 - 1.5 less than closing voltage.
Voltage Limiter	E- D	7.1 - 7.5 volts.
Maximum Reverse Current	E- D	6 amps. at 6 volts min.
Battery: (Extra cost equipment)		
Type	E- D	6 volt.
Number of Plates (per cell)	E- D	13
Min. capacity amp. Hrs.	E- D	80
Terminal Grounded	E- D	Positive
Starting Motor:		
Type	E- D	6 volt
Drive	E- D	Follow through type.

HYDRAULIC PUMP
(Extra Cost Equipment)

	Model	
Type	E- D	Adjustable control.
Maximum Pressure	E- D	1750 - 2000 lbs. per sq. in.
Pump:		
Type	E- D	Balanced vane.
Drive	E- D	Gear on engine camshaft.
Capacity	E- D	.4 to 4.8 G. P. M. at 2200 R. P. M.
Control	E- D	Manual.
Compression Pressure at Sea Level, Cranking Speed, Plugs Out, and Throttle Open	E	125 P. S. I. at 120 R. P. M.
	D	135 P. S. I. at 120 R. P. M.

IGNITION SYSTEM

	Model	
Type	E- D	Battery
Distributor:		
Firing Order	E- D	1-2-4-3
Drive	E- D	Helical gear off camshaft.
Automatic Spark Advance	E- D	Centrifugal
Initial Timing (degrees of crankshaft)	E	8° BTDC at 450 R. P. M.
" " "	D	5° BTDC at 450 R. P. M.
Maximum Advance (degrees of crankshaft)	E	29° to 31°
	D	26° to 28°
Distributor Breaker Cam	E- D	4 lobe
Breaker Contacts	E- D	1 set
Breaker Contact Spacings	E- D	.024 to .026
Spark Plugs:		
Type	E- D	H-10
Size	E- D	14 mm
Gap	E- D	.025 - .028

CARBURETOR

Type	E- D	Single up-draft.
Idle Mixture Adjustment	E- D	3/4 to 1-1/4 turn open.
Main Fuel Jet Adjustment	E- D	1-1/4 turn open.
Idle Speed Adjustment	E- D	Screw on throttle shaft (450 R. P. M.)

GOVERNOR

	Model	
Type	E- D	Variable speed centrifugal flyball mounted direct to crankshaft.
Governed Speed Range	E- D	600 - 2400 R. P. M. No load.
Maximum Governed Speed Adjustment	E- D	Stop clamp on throttle rod.

Higher speeds obtainable by removing two balls 180 degrees apart.

COOLING SYSTEM

Radiator Cap	E- D	Pressure type.
Pressure Valve Opens	E- D	3.5 to 4.5 P. S. I.
Vacuum Valve Opens	E- D	1 P. S. I.
Capacity	E- D	15 qts.
Water Pump:		
Type	E- D	Centrifugal.

ENGINE SPECIFICATIONS

CYLINDER HEAD

Valve Stem to Guide Clearance:		
Intake	E- D	.001 - .002
Exhaust	E- D	.002 - .003
Valve Seat Angle	E- D	45°
Valve Seat Width (Exh.)	E- D	.065
Valve Seat Width (Int.)	E- D	.070
Valve Seat Runout (T. I. R.)	E- D	.002

CYLINDER BLOCK

Cylinder Bore Micro Finish (R. M. S.)	E- D	25 - 35
Cylinder Bore Size	E	3.4375
" " "	D	3.900
Maximum Cylinder Bore Taper	E- D	.001
Maximum Cylinder Bore Out of Round	E- D	.0005

CRANKSHAFT

Crankshaft End Play	E- D	.002 - .006
Main Journal Diameter(All)	E- D	2.4974 - 2.4982
Connecting Rod Journal Diameter (All)	E- D	2.2986 - 2.2978

<u>CRANKSHAFT (Cont'd)</u>	<u>Model</u>	
Connecting Rod Side Clearance	E- D	.003 - .007
Flywheel Runout (Total)	E- D	.005

CAMSHAFT

Camshaft Journal Oil Clearance	E- D	.0015 - .003
Camshaft End Play	E- D	.002 - .004
Journal Diameter (All)	E- D	1.9255 - 1.9265

ROCKER ARM SHAFT

Diameter	E- D	.780 - .781
Bearing (I. D.)	E- D	.783 - .784
Journal to Shaft Oil Clearance	E- D	.002 - .004

VALVES

Valve Stem to Guide Clearance	E- D	.002 - .003
Tappet Clearance Intake Valve (Hot)	E- D	.015
Tappet Clearance Exhaust Valve (Hot)	E- D	.015
Valve Seat Interference Angle	E- D	1/2° to 1-1/2°
Position dampening coil of spring at stem end of valve.		
Valve Spring Tension at 1.821"	E- D	54# to 62#
Valve Spring Tension at 1.505"	E- D	124# to 140#

PISTONS AND PINS

Assemble rod to piston so that dot in piston head faces toward fan end of engine, oil squirt hole in rod toward camshaft.

Piston Pin Diameter	E- D	.9120 - .9123
Piston Pin Clearance in Rod	E- D	.0001 - .0003

<u>PISTONS AND PINS (Cont'd)</u>	<u>Model</u>	
Piston Pin Clearance in Piston	E- D	.0001 - .0003

PISTON RINGS

Side Clearance - Top Ring	E- D	.002 - .0035
Side Clearance - Second Ring	E- D	.0015 - .003
Side Clearance - Oil Ring	E- D	.0015 - .003
Ring End Gap	E- D	.010 - .020
Stagger gaps 120° apart.		

Nut and Cap Screw Tightening Tension for E and D Engine

Main Bearing Bolts	95 - 105 ft. lbs.
Connecting Rod Nuts	45 - 50 ft. lbs.
Connecting Rod Pal Nuts	Finger tight plus 1/4 turn.
Cylinder Head Bolts	65 - 70 ft. lbs.
Oil Pan to Block	15 - 18 ft. lbs.
Oil Filter to Block	20 - 25 ft. lbs.
Camshaft Gear to Shaft	45 - 50 ft. lbs.
Cylinder Block Front Cover Cap Screws	15 - 18 ft. lbs.
Governor Case Cap Screws	6 - 10 ft. lbs.
Rocker Arm Shaft Supports to Cylinder Head	45 - 50 ft. lbs.
Manifold Nuts	40 - 50 ft. lbs.
Rocker Arm Cover to Cylinder Head	8 - 10 ft. lbs.
Flywheel to Crankshaft Cap Screws	75 - 85 ft. lbs.

NOTES

NOTES

NOTES
