



# Operator Manual

Our energy working for you.™



with PowerCommand® Control 1301 - Rental

Volume 2 – Section 8 - Appendices



## SECTION 8 - APPENDICES



***THIS IS A BLANK PAGE***



## FOREWORD

This manual should be read in conjunction with the PowerCommand® Control 1301 Manual 0908-0118-00 Volume 1. It contains additional, generator set specific, information and should form part of the documentation package supplied with the generator set.

The information contained within this manual is based on information available at the time of going to print. In line with Cummins Power Generation Limited policy of continuous development and improvement, information may change at any time without notice. The users should therefore ensure that before commencing any work, they have the latest information available.

Should you require any further assistance contact:

Cummins Power Generation  
1400 73<sup>rd</sup> Avenue NE  
Minneapolis  
MN 55432  
USA

Cummins Power Generation  
Columbus Avenue  
Manston Park  
Manston  
Ramsgate  
Kent CT12 5BF  
United Kingdom

Cummins Power Generation  
10 Toh Guan Road #07-01  
TT International Tradepark  
Singapore 608838

Tel:+1 (763) 574-5000  
Fax:+1 (763) 574-5298

Tel:+44 (0) 1843 255000  
Fax:+44 (0) 1843 255902

Tel: (65) 6417 2388  
Fax:(65) 6417 2399

e-mail: [pgamail@cummins.com](mailto:pgamail@cummins.com)

e-mail: [cpgk.uk@cummins.com](mailto:cpgk.uk@cummins.com)

e-mail: [cpg.apmktg@cummins.com](mailto:cpg.apmktg@cummins.com)

Web: [www.cumminspower.com](http://www.cumminspower.com)

Web: [www.cumminspower.com](http://www.cumminspower.com)

Web: [www.cumminspower.com](http://www.cumminspower.com)

Cummins Power Generation  
35A/1/2, Erandawana  
Pune 411 038  
India

Cummins Power Generation  
Rua Jati, 310 - Cumbica  
Guarulhos –SP  
Brazil  
CEP: 07180-900

Tel.: (91 020) 3024 8600  
Fax: (91 020) 6602 8090

Tel.: (55 11) 2186 4195  
Fax: (55 11) 2186 4729

e-mail:  
[cpgiservicesupport@cummins.com](mailto:cpgiservicesupport@cummins.com)

e-mail: [falecom@cumminspower.com.br](mailto:falecom@cumminspower.com.br)

Web: [www.cumminspower.com](http://www.cumminspower.com)

Web: [www.cumminspower.com](http://www.cumminspower.com)

***THIS IS A BLANK PAGE***



## CONTENTS

| Section            | Title  | Page       |
|--------------------|--|------------|
| <b>APPENDIX: A</b> | <b>Additional Engine Specific Information.....</b>           | <b>A-1</b> |
| A.1                | Engine Specific Information C13, C20, C30, C35 and C50 ..... | A-1        |
| A.1.1              | Generator Set Details .....                                  | A-1        |
| A.2                | Engine Specific Information C70, C100, C150 and C200.....    | A-2        |
| A.2.1              | Generator Set Details .....                                  | A-2        |
| A.3                | Engine Specific Information - C250 D2R .....                 | A-3        |
| A.3.1              | Generator Set Details .....                                  | A-3        |
| <b>APPENDIX: B</b> | <b>ISBe Generator Set Control System.....</b>                | <b>B-1</b> |
| B.1                | Scope .....  | B-1        |
| B.2                | ISBe Control Panel.....                                      | B-2        |
| B.3                | Alternator .....   | B-2        |
| B.4                | ISBe Engine Diagnostics.....                                 | B-3        |
| B.4.1              | Offboard Diagnostics .....                                   | B-3        |
| B.4.2              | Onboard Diagnostics .....                                    | B-3        |
| B.4.3              | Onboard Diagnostics – Fault Detection.....                   | B-3        |
| B.4.4              | General Notes.....   | B-4        |
| <b>APPENDIX: C</b> | <b>C13 Series .....</b>                                      | <b>C-1</b> |
| C.1                | Scope .....  | C-1        |
| C.2                | Alternator.....  | C-2        |
| <b>APPENDIX: D</b> | <b>C20 to C50 Series .....</b>                               | <b>D-1</b> |
| D.1                | Scope .....  | D-1        |
| D.2                | Alternator.....  | D-2        |
| <b>APPENDIX: E</b> | <b>C70 to C200 Series .....</b>                              | <b>E-1</b> |
| E.1                | Scope .....  | E-1        |
| E.2                | Alternator.....  | E-2        |
| <b>APPENDIX: F</b> | <b>C250 D2R Series QSL9.....</b>                             | <b>F-1</b> |
| F.1                | Scope .....  | F-1        |
| F.2                | Control Panel.....   | F-2        |
| F.2.1              | Emergency Stop Button.....                                   | F-2        |
| F.2.2              | Operating Modes .....  | F-2        |
| F.3                | DC Electrical System .....                                   | F-3        |
| F.3.1              | Battery Disconnection.....                                   | F-3        |
| F.4                | Control System Overview.....                                 | F-3        |
| F.5                | Additional Fault Codes .....                                 | F-4        |
| F.6                | Alternator.....  | F-4        |

## Illustrations

| Figure     | Title                                  | Page |
|------------|--|------|
| Figure B-1 | Typical ISBe Generator Set.....        | B-1  |
| Figure B-2 | ISBe Control Panel.....                | B-2  |
| Figure C-1 | Typical C13 Generator Set.....         | C-1  |
| Figure D-1 | Typical C20 to C50 Generator Set.....  | D-1  |
| Figure E-1 | Typical C70 to C200 Generator Set..... | E-1  |
| Figure F-1 | Typical C250 Generator Set.....        | F-1  |
| Figure F-2 | QSL9 Control Panel .....               | F-2  |



## APPENDIX: A Additional Engine Specific Information

### A.1 Engine Specific Information C13, C20, C30, C35 and C50

#### A.1.1 Generator Set Details

| MODEL   |  | C13  | C20                    | C30                    | C35                    | C50                     |
|---|--|--|------------------------|------------------------|------------------------|-------------------------|
| Engine  | Cummins Diesel Series                                  | D1703  | 4B3.3-G1               | 4B3.3-G1               | 4B3.3-G1               | 4BT3.3G2                |
| Generator   | Power kW Rating  | See Generator Set Nameplate for rating information |                        |                        |                        |                         |
| Electrical System   | Starting Voltage                                       | 12 Volts DC  | 12 Volts DC            | 12 Volts DC            | 12 Volts DC            | 12 Volts DC             |
|   | Battery  | One x 12Volt                                       | One x 12Volt           | One x 12Volt           | One x 12Volt           | One x 12Volt            |
|   | Cold Cranking Amps (CCA) (min) cold soak @ 0°F (-18°C) | 120  | 550                    | 550                    | 550                    | 550                     |
| Cooling System  | Capacity with Standard Radiator                        | 1.05 Imp Gall (4.75L)                              | 1.74 Imp Gall (7.91L)  | 1.74 Imp Gall (7.91L)  | 1.74 Imp Gall (7.91L)  | 1.74 Imp Gall (7.91L)   |
| <sup>1</sup> Lubricating System   | Oil Capacity (including filters) Standard Oil Pan only | 1.54 Imp Gall (7.0L)                               | 1.75 Imp Gall (8.0L)   | 1.75 Imp Gall (8.0L)   | 1.75 Imp Gall (8.0L)   | 1.75 Imp Gall (8.0L)    |
| <sup>2</sup> Fuel Consumption   | Standby/Full Load/50Hz                                 | <1.4 Imp Gall 6.24L/Hr                             | 2.1 Imp Gall (9.4L/Hr) | 2.1 Imp Gall (9.4L/Hr) | 2.1 Imp Gall (9.4L/Hr) | 2.8 Imp Gall (12.9L/Hr) |
| <sup>3</sup> Enclosed Set Acoustic Data - LWA   | Operating with doors closed                            | 97   | 97                     | 97                     | 97                     | 97                      |
| <sup>4</sup> Open Set Acoustic Data dB(A) at 1m - SPL   | At operating point with doors open                     | 86   | 91                     | 91                     | 91                     | 91                      |
| <sup>1.</sup> Refer to the Engine Manual for lubricating oil recommendations and specifications.<br><sup>2.</sup> Refer to Data Sheets for other applications<br><sup>3.</sup> Doors closed figures are calculated from 2000/14/EC guaranteed sound power levels.<br><sup>4.</sup> For noise Spectrum figures refer to Health and Safety Manual (0908-0110-00).<br>In line with the CPGK policy of continuous improvement, these figures are subject to change. |  |  |                        |                        |                        |                         |

## A.2 Engine Specific Information C70, C100, C150 and C200

### A.2.1 Generator Set Details

| MODEL  |   | C70  | C100                        | C150                        | C200                       |
|--|---|--|-----------------------------|-----------------------------|----------------------------|
| Engine   | Cummins Diesel Series                                       | 4BTA3.9G4  | 4ISBeG1                     | 6ISBeG1                     | 6CTAA8.3G2                 |
| Generator  | Power (kW) Rating   | See Generator Set Nameplate for rating information |                             |                             |                            |
| Electrical System  | Starting Voltage  | 12 Volts DC  | 12 Volts DC                 | 12 Volts DC                 | 12 Volts DC                |
|  | Battery   | One x 12Volt                                       | One x 12Volt                | One x 12 Volt               | One x 12Volt               |
|  | Cold Cranking Amps (CCA minimum)<br>cold soak @ 0°F (-18°C) | 625  | 800                         | 950                         | 950                        |
| Cooling System   | Capacity with Standard Radiator                             | 3.8 Imp Gall<br>(17.2L)                            | 4.3 Imp Gall<br>(19.3L)     | 5.1 Imp Gall<br>(23L)       | 5.8 Imp Gall<br>(26.3L)    |
| <sup>1</sup> Lubricating System  | Oil Capacity including Filters                              | 2.4 Imp Gall<br>(11L)                              | 2.9 Imp Gall<br>(13L)       | 4.3 Imp Gall<br>(19.5L)     | 5.2 Imp Gall<br>(23.8L)    |
| <sup>2</sup> Fuel Consumption  | Standby/Full Load/50Hz                                      | 4.6 Imp Gall<br>(21 L/Hour)                        | 5.5 Imp Gall<br>(25 L/Hour) | 8.8 Imp Gall<br>(40 L/Hour) | 12.5 Imp Gall<br>57 L/Hour |
| <sup>3</sup> Enclosed Set Acoustic Data - LWA  | Operating with doors closed                                 | 97   | 97                          | 97                          | 97                         |
| <sup>4</sup> Open Set Acoustic Data dB(A) at 1m - SPL  | At operating point with doors open                          | 101  | 107                         | 102                         | 106                        |
| <ol style="list-style-type: none"> <li>1. Refer to the engine manual for lubricating oil recommendations/specifications.</li> <li>2. Refer to Data Sheet for other applications.</li> <li>3. Doors closed figures are calculated from 2000/14/EC guaranteed sound power levels.</li> <li>4. For noise Spectrum figures refer to Health and Safety Manual (0908-0110-00).<br/>In line with the CPGK policy of continuous improvement these figures are subject to change</li> </ol> |   |  |                             |                             |                            |

## A.3 Engine Specific Information - C250 D2R

### A.3.1 Generator Set Details

| MODEL  |   | C250 D2R   |
|--|---|--|
| Engine   | Cummins Diesel Series                                       | QSL9G5   |
| Generator  | Power (kW) Rating   | See Generator Set Nameplate for rating information |
| Electrical System  | Starting Voltage  | 24 Volts DC  |
|  | Battery   | Two x 12Volt                                       |
|  | Cold Cranking Amps (CCA minimum)<br>cold soak @ 0°F (-18°C) | 750  |
| Cooling System   | Capacity with Standard Radiator                             | 6.29 Imp Gall<br>(28.6 L)                          |
| <sup>1</sup> Lubricating System  | Oil Capacity including Filters                              | 5.8 Imp Gall<br>(26.5L)                            |
| <sup>2</sup> Fuel Consumption  | Standby/Full Load/50Hz                                      | 16.5 Imp Gall<br>(75 L/Hour)                       |
| <sup>3</sup> Enclosed Set Acoustic Data - LWA  | Operating with doors closed                                 | 96   |
| <sup>4</sup> Open Set Acoustic Data dB(A) at 1m - SPL  | At operating point with doors open                          | 100.3  |
| <ol style="list-style-type: none"> <li>1. Refer to the engine manual for lubricating oil recommendations/specifications.</li> <li>2. Refer to Data Sheet for other applications.</li> <li>3. Doors closed figures are calculated from 2000/14/EC guaranteed sound power levels.</li> <li>4. For noise Spectrum figures refer to Health and Safety Manual (0908-0110-00).<br/>In line with the CPGK policy of continuous improvement these figures are subject to change</li> </ol> |   |  |

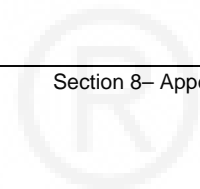
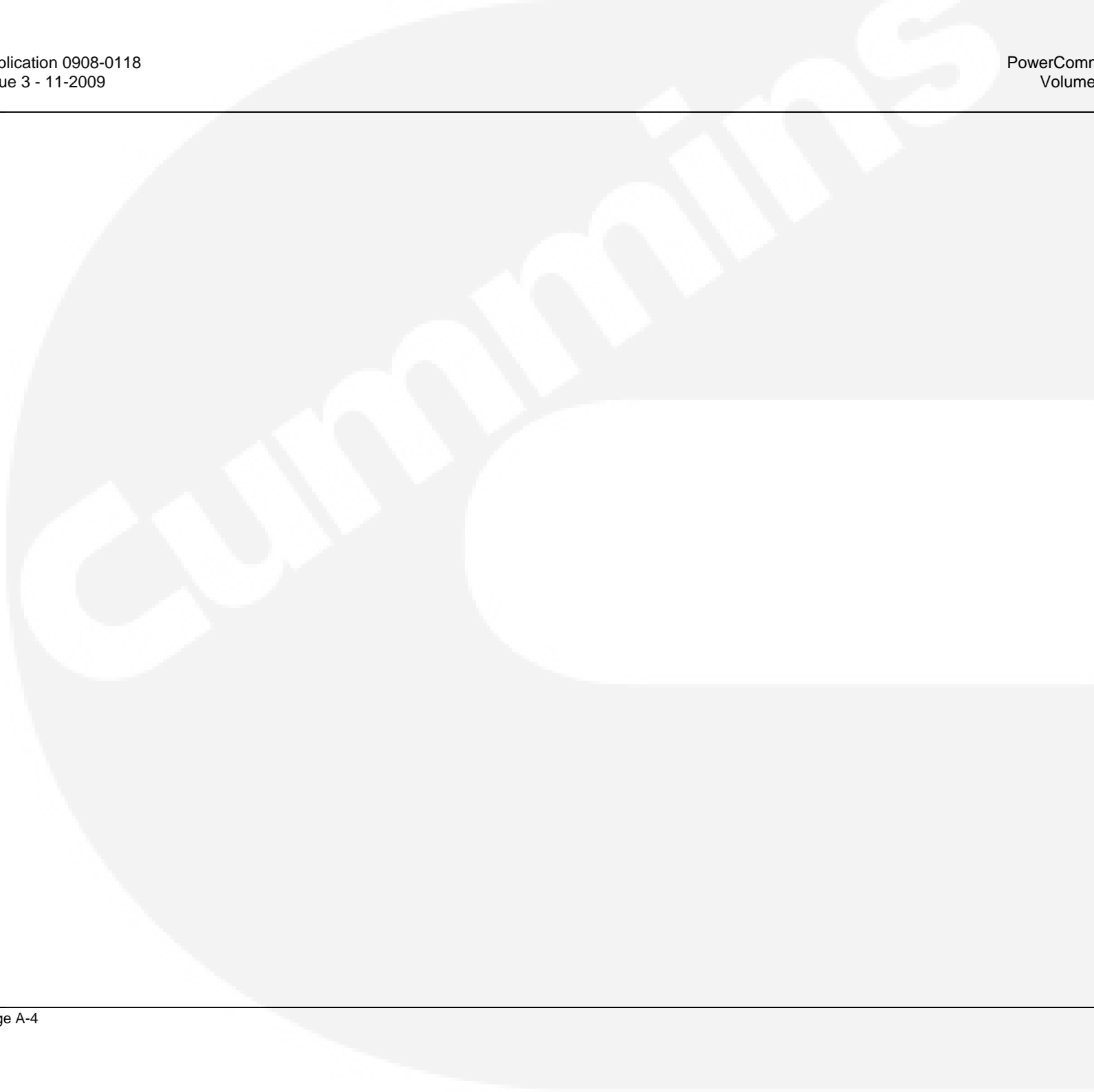

## APPENDIX: B ISBe Generator Set Control System

### B.1 Scope

This section describes the additional control system information required for the operation and maintenance of the following generator set models:

- C100 (4ISBe)
- C150 (6ISBe)
- The ISBe diagnostics control panel assembly is situated within the control housing assembly and is mounted below the PCC1301 control panel, as shown.

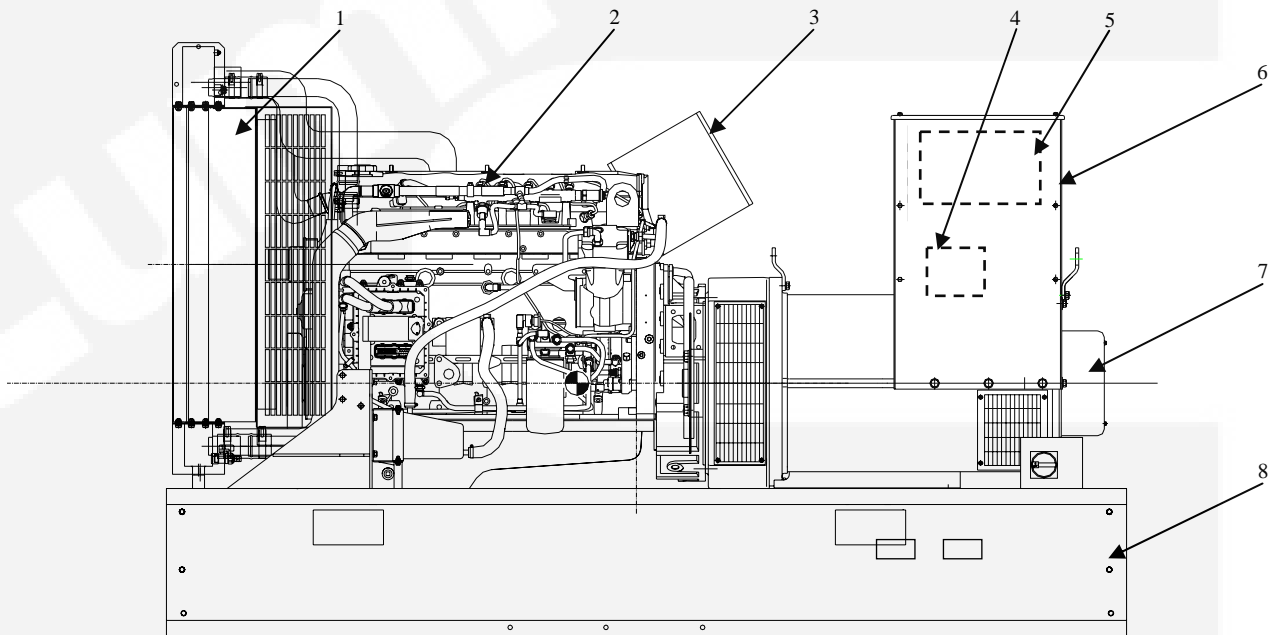

Figure B-1 Typical ISBe Generator Set

#### KEY

- |                       |                                    |
|-----------------------|------------------------------------|
| 1. Radiator           | 5. PCC1301 Control Panel (Typical) |
| 2. Engine             | 6. Control Housing                 |
| 3. Air Cleaner        | 7. Alternator                      |
| 4. ISBe Control Panel | 8. Bed-frame                       |

Note: Items 4 and 5 situated on the far side of the Control Housing.

## B.2 ISBe Control Panel

The main control panel for the ISBe diagnostics control system forms the front panel of the assembly.

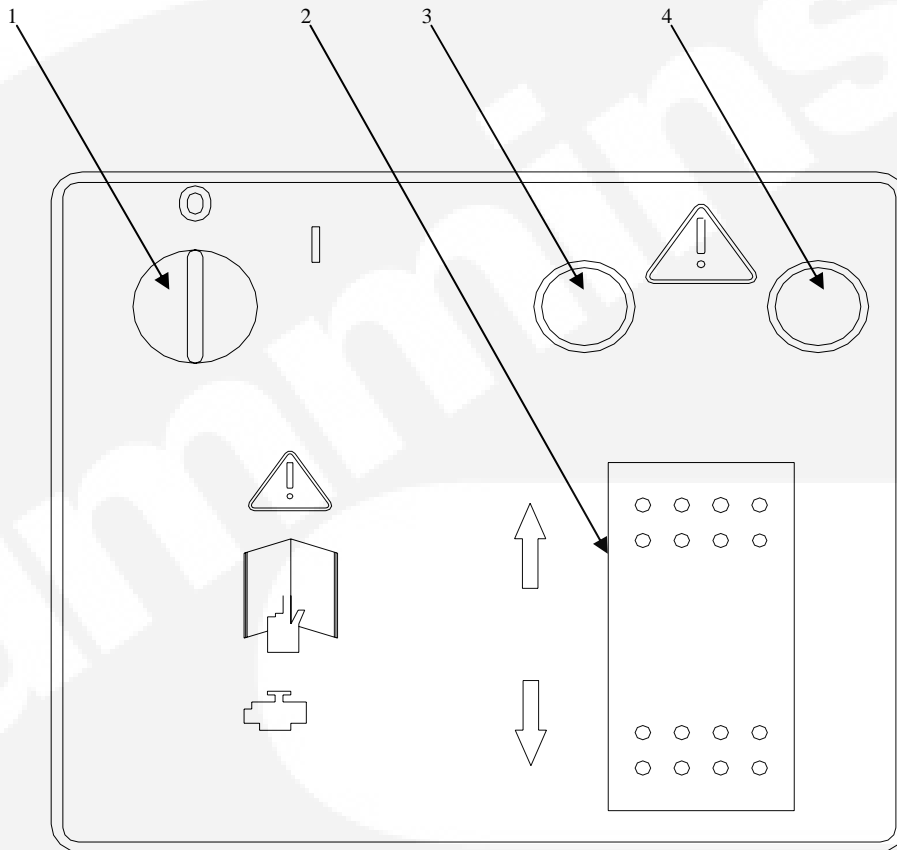

Figure B-2 ISBe Control Panel

1. Mode key switch
2. Rocker switch
3. Red Stop Lamp
4. Amber Warning Lamp

## B.3 Alternator

The standard alternators, for the ISBe generator sets, do not require greasing of the bearings. These bearings are sealed for life. However, they should be checked for wear during standard maintenance periods.

## B.4 ISBe Engine Diagnostics

Advanced engine diagnostics are included to make the Cummins' ISBe engines straightforward to repair and service. These diagnostics complement the separate PCC3101 fault protection and diagnostic system.

### B.4.1 Offboard Diagnostics

- INSITE is a Windows based PC service tool which assists with the troubleshooting and repair aspects of Cummins' ISBe engines.
- For further information contact your nearest Cummins Distributor.

### B.4.2 Onboard Diagnostics

- Provide extensive fault detection capability within the Engine Control Module (ECM).
- Flash-out of Fault codes using red or amber lamps.
- Fault lamps located on the engine diagnostic panel, situated below the PCC1301 control panel, indicate Warning/Stop conditions.

### B.4.3 Onboard Diagnostics – Fault Detection

Faults are records of system problems detected while the generator set is running. Should a problem be detected, a fault is logged in the memory together with a snapshot of the generator set parameters. In addition, certain faults may illuminate the Warning lamp or the Stop lamp, dependent on the severity of the active fault.

Use the following procedure to list any recorded fault codes and advise your authorised distributor to determine any subsequent action required.

#### B.4.3.1 Flash-out of Fault Codes

**WARNING:** THIS OPERATION MUST BE CARRIED OUT WITH THE GENERATOR SET AT REST. UNDER NO CIRCUMSTANCES SHOULD THE ENGINE DIAGNOSTIC MODE BE SELECTED WHILE THE GENERATOR SET IS RUNNING.

**Note:** The PCC1301 mode switch must be in the Off  position before engine diagnostic mode is selected. Once the engine diagnostic mode has been selected, generator set Manual and Auto start will be inhibited.

1. The diagnostic mode key switch must be in the On (I) position to flash out the fault codes.
2. In the diagnostic mode:
  - a) With no active faults, the Warning and Stop lamps will be illuminated without flashingOR
  - b) With active faults, the ECM will begin to flash out codes by first turning on the Warning lamp.
3. The Warning lamp will then turn off and the ECM will begin flashing the Stop lamp in sequence to represent the active fault code number.
4. As the fault code is flashed, short pauses will occur to indicate completion of each digit. The Warning lamp will illuminate to indicate the beginning of a fault code.
5. The ECM will continue to flash a fault until the operator uses the Fault increment (↑) or decrement (↓) rocker switch to change to a new fault.
6. The ISBe control system uses three and four digit fault codes.

7. The diagnostic mode will remain active until the diagnostic switch is turned Off (O).

#### B.4.4 General Notes

1. On generator set start-up the Warning and Stop lamps will illuminate for approximately two seconds before shutting off in sequence, to verify that they are working correctly. This is part of the normal operation of the power-up sequence. If an active fault is present after this sequence, one of the lamps will remain illuminated, dependent on the type of fault sensed.
2. The Warning lamp indicates an active component, or system fault. While it denotes a failure has occurred, it is not considered an emergency.
3. The Stop lamp indicates a major ISBe engine failure, and the generator set should not be operated until the fault has been rectified.
4. Any fault indication should always be investigated and the appropriate action taken. If in doubt contact your nearest Cummins Dealer for advice/service.
5. In extreme cases the ECM will shut down the generator set on detection of a serious fault, independently of the PCC1301 control. This occurrence will be indicated on the engine diagnostic panel by illumination of the Stop lamp (this lamp may also flash prior to the Shutdown). The PCC1301 will detect this as an Underspeed or Low Oil Pressure Shutdown fault.
6. A minimum period of 30 seconds must elapse between engine stop and battery disconnection to allow the ECM time to save data to non-volatile memory.

**Note:** *Failure to do this will cause a Warning fault to be registered on the next generator set start.*

7. To enable Off-board diagnostics via INSITE, the diagnostic mode key switch should be turned to the On (I) position.

**Note:** *The generator set should be at rest and the PCC1301 mode switch should be in the Off  position before engine diagnostic mode is selected.*



## APPENDIX: C C13 Series

### C.1 Scope

The information contained within this section is generic only.

For installation specific drawings refer to drawings supplied with the generator set documentation package.

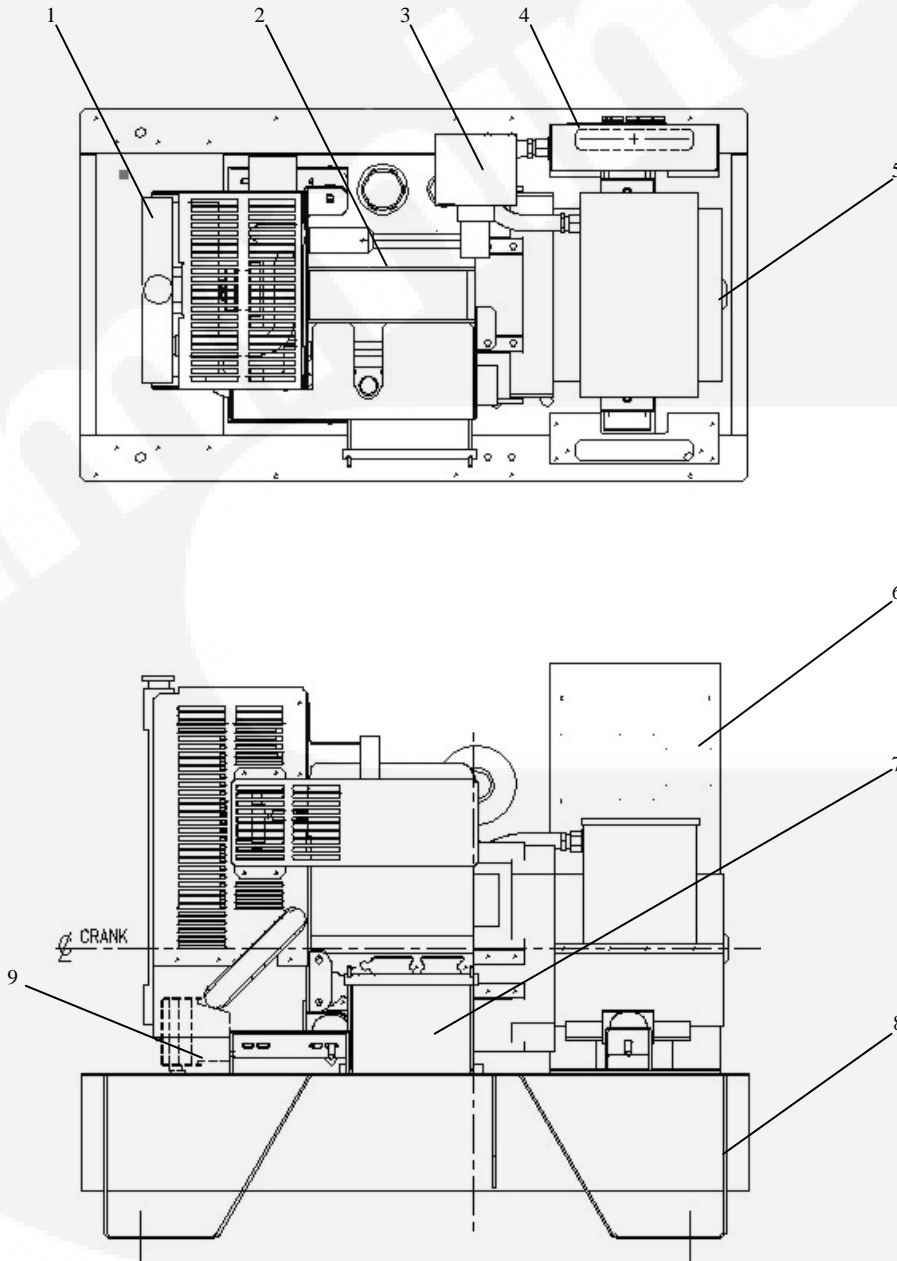

Figure C-1 Typical C13 Generator Set

#### KEY

- |   |   |
|---|---|
| 1. Radiator                                 | 6. Control Housing and Controller PCC1301 |
| 2. Engine                                   | 7. Battery                                |
| 3. Air Cleaner                              | 8. Bed-frame                              |
| 4. Gland Plate (Customer cable connections) | 9. Coolant Heater (option)                |
| 5. Alternator                               |   |

## C.2 Alternator

The standard alternator for the C13 generator set does not require greasing of the bearings. These bearings are sealed for life. However they should be checked for wear during standard maintenance periods.



## APPENDIX: D C20 to C50 Series

### D.1 Scope

The information contained within this section is generic only.

For installation specific drawings refer to drawings supplied with the generator set documentation package.

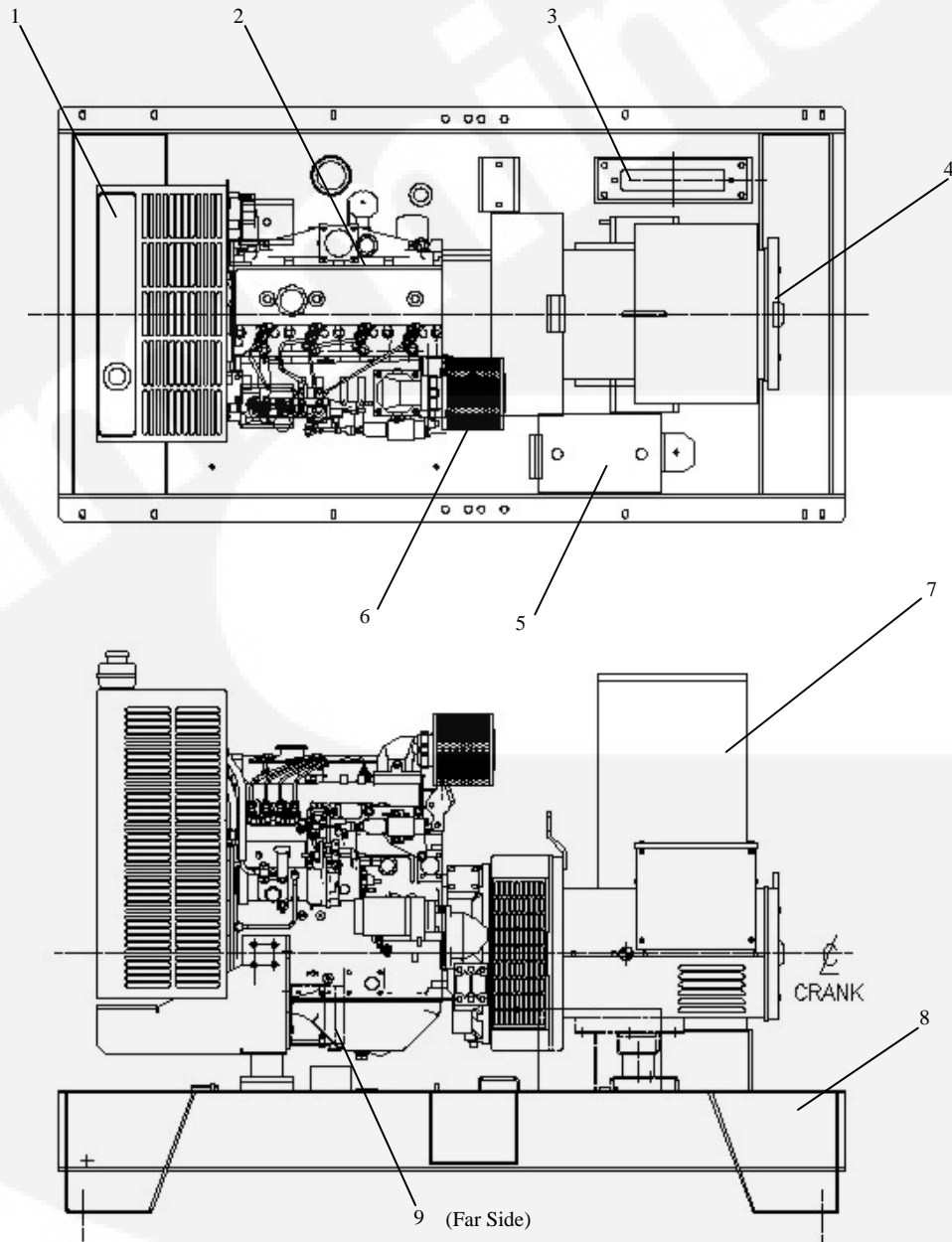

Figure D-1 Typical C20 to C50 Generator Set

#### KEY

- |  |   |
|--|---|
| 1. Radiator                                | 6. Air Cleaner                            |
| 2. Engine                                  | 7. Control Housing and Controller PCC1301 |
| 3. Gland Plate (Customer cable connection) | 8. Bed-frame                              |
| 4. Alternator                              | 9. Coolant Heater (option)                |
| 5. Battery                                 |   |

## D.2 Alternator

The standard alternators for the C20 to C50 generator sets do not require greasing of the bearings. These bearings are sealed for life. However they should be checked for wear during standard maintenance periods.



## APPENDIX: E C70 to C200 Series

### E.1 Scope

The information contained within this section is generic only.

For installation specific drawings refer to drawings supplied with the generator set documentation package.

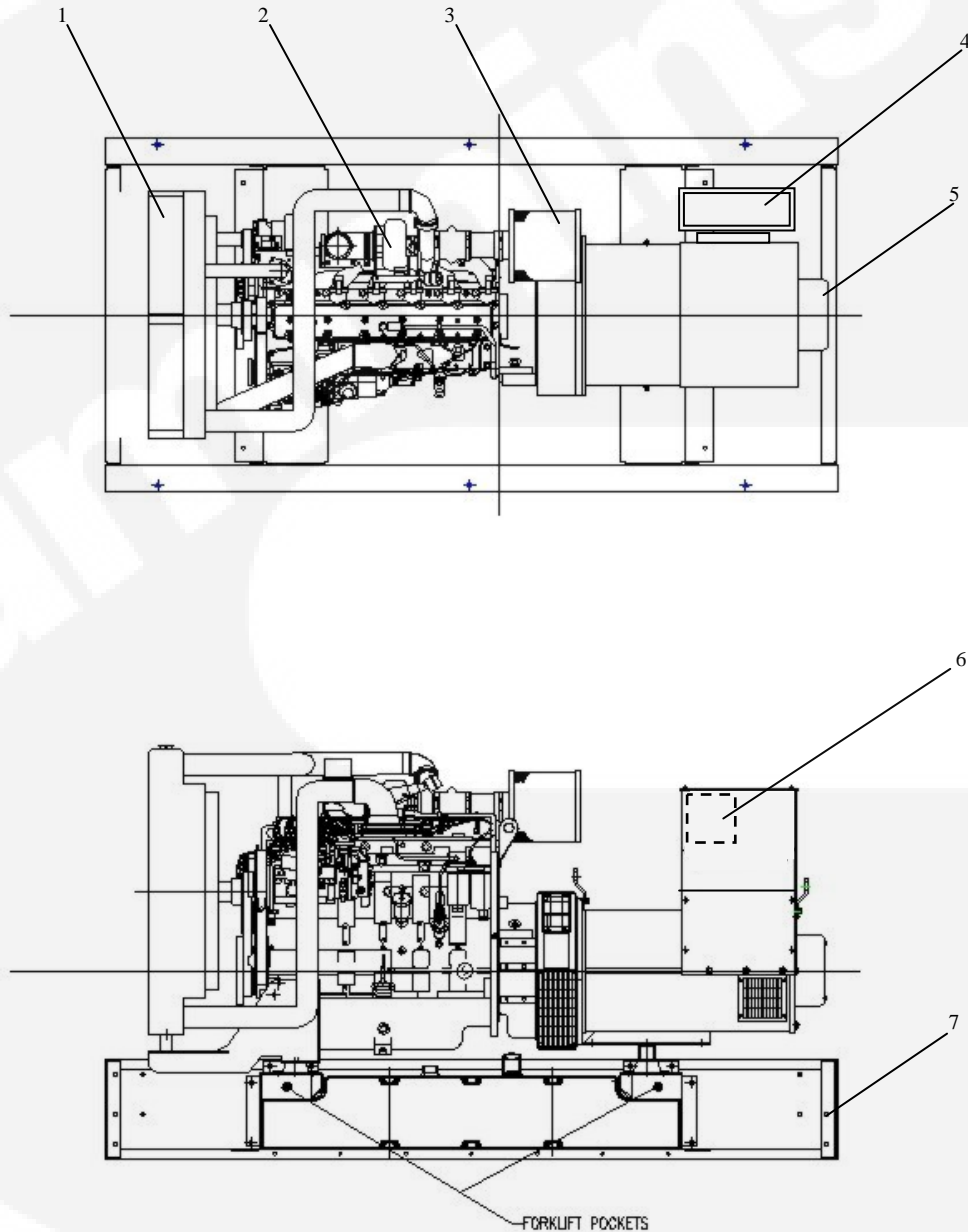

Figure E-1 Typical C70 to C200 Generator Set

#### KEY

- |                    |                          |
|--------------------|--------------------------|
| 1. Radiator        | 5. Alternator            |
| 2. Engine          | 6. PCC1301 Control Panel |
| 3. Air Cleaner     | 7. Bed-frame             |
| 4. Control Housing |                          |

Note: Item 6 situated on the far side of the Control Housing.

## E.2 Alternator

The standard alternators, for generator sets in the C70 to C200 range, do not require greasing of the bearings. These bearings are sealed for life. However they should be checked for wear during standard maintenance periods.



## APPENDIX: F C250 D2R Series QSL9

### F.1 Scope

This section describes the additional information required for the operation and maintenance of the C250 D2R generator set.

The main components (less the SilentPower™ canopy) of a typical C250- D2R generator set are shown below. Refer to Volume 1 for basic, generic information.

For installation specific drawings refer to drawings supplied with the generator set documentation package.

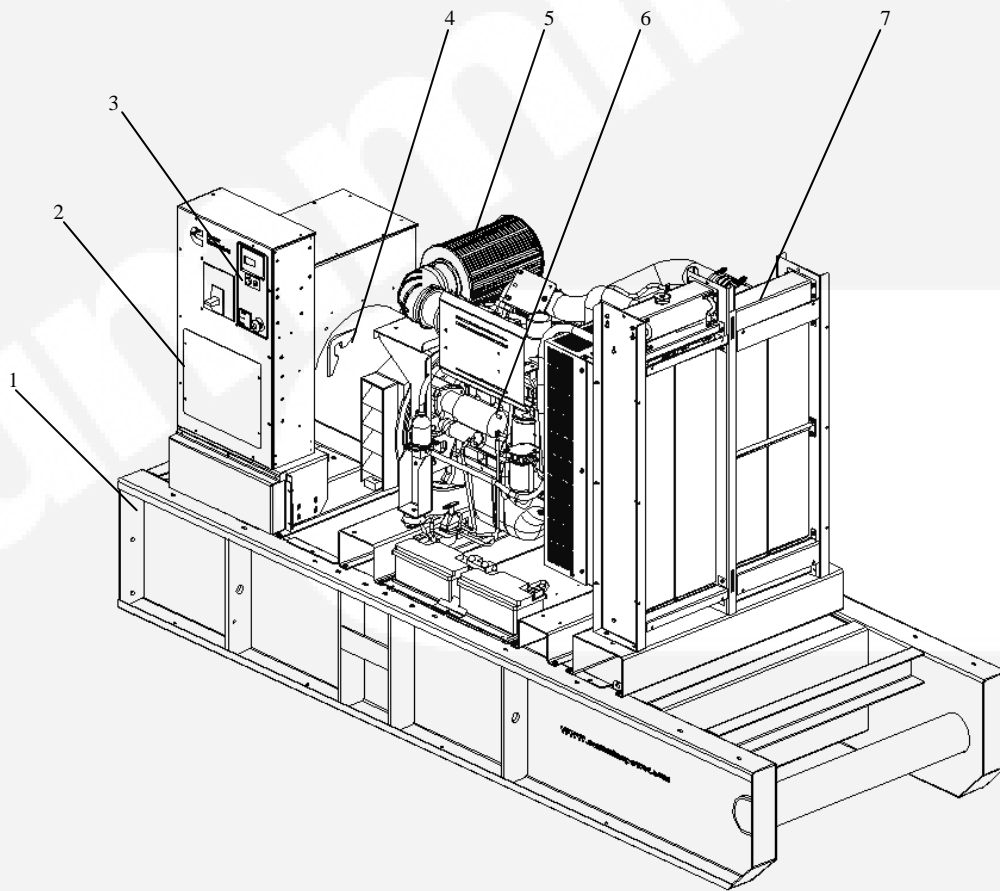

Figure F-1 Typical C250 Generator Set

#### KEY

- |    |                       |    |             |
|----|-----------------------|----|-------------|
| 1. | Bed-frame             | 5. | Air Cleaner |
| 2. | Control Housing       | 6. | Engine      |
| 3. | PCC1301 Control Panel | 7. | Radiator    |
| 4. | Alternator            |    |             |

## F.2 Control Panel

The Control Panel layout, for the QSL9 generator set, has been re-configured whilst utilising the same components as the smaller, standard rental sets. Refer to Figure F-2.

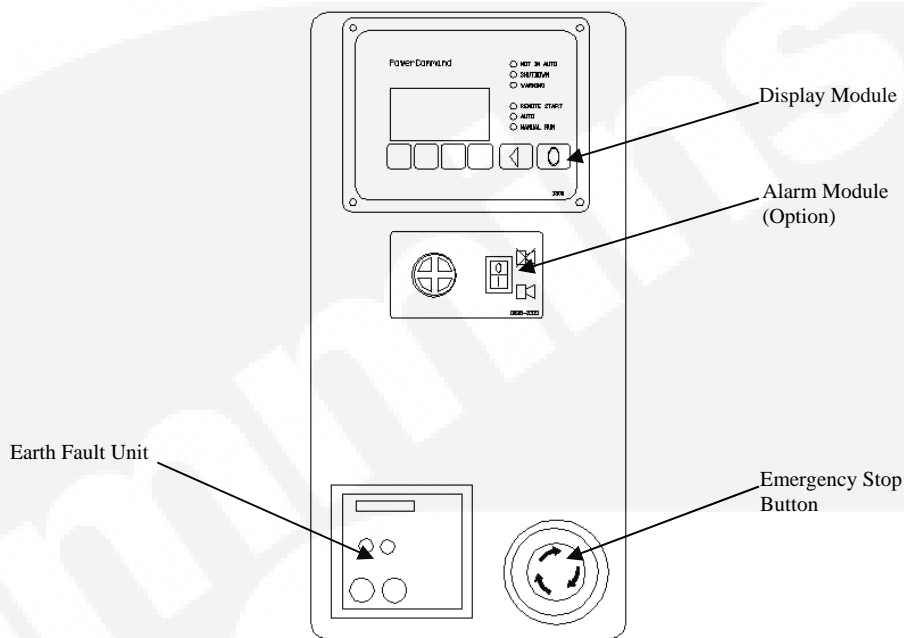

Figure F-2 QSL9 Control Panel

### F.2.1 Emergency Stop Button

For the QSL9 configured generator sets the Emergency Stop Button is situated on the lower, right hand side of the Control Panel. Push this button in for an Emergency Shutdown of the engine. (Refer to Volume 1 Section 3.2.4).

**Note:** Refer to Section F3.1.

### F.2.2 Operating Modes

The QSL9 configured generator sets operate with Off, Manual Run, and Auto Modes.

**Note:** Sleep Mode, and Battle Short Mode operation are not applicable to this set.



## F.3 DC Electrical System

The standard control system for the QSL9 configured generator sets operate on 24V DC battery power.

A 24 volt battery system provides multi-attempt engine starting and DC power for the generator system.

**Note:** *It may be necessary to upgrade the battery system if the generator set will be operating in arctic conditions.*

### F.3.1 Battery Disconnection

Prior to disconnection/isolation of the generator set battery supply (24V DC), and with the generator set at rest, the Emergency Stop system should be activated for a minimum of 30 seconds. This is to allow engine control run data to be saved to non volatile memory. If this procedure is not followed, data may become corrupted and impair the efficient operation of the generating set.

In the event of battery disconnection/isolation without Emergency Stop activation a fault will be registered within the engine control system and annunciated via the generator set control display as Fault Code 251 'Unknown J1939 Fault'.

## F.4 Control System Overview

The generator set control system consists of two main subsystems:

- Generator Set Control (PCC1301)

This control covers the following functions: Operator Interface, Operating Logic, Non-Engine Fault Protection & System Wide Fault Management.





An I/O module, as a part of the generator set control subsystem, functions as an interface between the CAN Link and the PCC1301 Control Module.

- Engine Control (CM850).

This control covers the Engine Performance Management & Engine Fault Protection Functions.

The two subsystems communicate and function together via a Controller Area Network (CAN) digital communications link to the SAE J1939 Standard.

## F.5 Additional Fault Codes

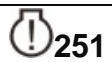
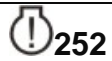
| CTG | CODE | LAMP     | DISPLAYED MESSAGE/SYMBOLS |   | DESCRIPTION  |
|-----|------|----------|---------------------------|---|--|
|     |      |          | TEXT VERSION              | SYMBOLIC VERSION  |  |
| A   | 104  | Shutdown | Unknown J1939 Fault       |  104   | Indicates that a non specified engine shutdown fault (initiated by the Engine Control) has occurred  |
| A   | 105  | Shutdown | J1939 Datalink Lost       |  105   | Indicates that CAN digital communication between the engine and generator set controls have failed   |
| A   | 106  | Shutdown | I/O Module Lost           |  106   | Indicates that the I/O Module has failed. May prevent engine and generator set control communication.  |
| C   | 250  | Warning  | J1939 Datalink Lost       |  250   | Indicates that CAN digital communication between the engine and generator set controls have failed. This may be a temporary or resolved condition. This fault can be temporarily displayed during fault acknowledge/reset operations |
| C   | 251  | Warning  | Unknown J1939 Fault       |  251  | Indicates that a non specified engine warning fault (initiated by the Engine Control) has occurred. Can be caused by battery disconnection/isolation without a run data save operation.  |
| B   | 252  | Warning  | I/O Module Lost           |  252 | Indicates that the I/O Module has failed. May prevent engine and generator set control communication. This may be a temporary or resolved condition.   |

## F.6 Alternator

The standard alternators, for the C250 D2R generator sets, do not require greasing of the bearings. These bearings are sealed for life. However, they should be checked for wear during standard maintenance periods.



Cummins Power Generation  
1400 73<sup>rd</sup> Avenue NE  
Minneapolis  
MN 55432  
USA

Tel: +1 (763) 574-5000  
Fax: +1 (763) 574-5298

e-mail: [pgamail@cummins.com](mailto:pgamail@cummins.com)

Web: [www.cumminspower.com](http://www.cumminspower.com)

Cummins Power Generation  
35A/1/2, Erandawana  
Pune 411 038  
India

Tel.: (91 020) 3024 8600  
Fax: (91 020) 6602 8090

e-mail:  
[cpgiservicesupport@cummins.com](mailto:cpgiservicesupport@cummins.com)

Web: [www.cumminspower.com](http://www.cumminspower.com)

Cummins Power Generation  
Columbus Avenue  
Manston Park  
Manston  
Ramsgate  
Kent CT12 5BF  
United Kingdom

Tel: +44 (0) 1843 255000  
Fax: +44 (0) 1843 255902

e-mail: [cpgk.uk@cummins.com](mailto:cpgk.uk@cummins.com)

Web: [www.cumminspower.com](http://www.cumminspower.com)

Cummins Power Generation  
Rua Jati, 310 - Cumbica  
Guarulhos -SP  
Brazil  
CEP: 07180-900

Tel.: (55 11) 2186 4195  
Fax: (55 11) 2186 4729

e-mail: [falecom@cumminspower.com.br](mailto:falecom@cumminspower.com.br)

Web: [www.cumminspower.com](http://www.cumminspower.com)

Cummins Power Generation  
10 Toh Guan Road #07-01  
TT International Tradepark  
Singapore 608838

Tel: (65) 6417 2388  
Fax: (65) 6417 2399

e-mail: [cpg.apmktg@cummins.com](mailto:cpg.apmktg@cummins.com)

Web: [www.cumminspower.com](http://www.cumminspower.com)

Cummins®, the “C” logo, and “Our energy working for you.”  
are trademarks of Cummins Inc.

©2009 Cummins Power Generation, Inc. All rights reserved

