



Operator Manual

Performance you rely on.™



50 Hz Commercial Portable Generator Set

EGMBL / PX4800
EGMBL / PX4800e



**For Parts Ordering and Technical Support
Please Contact**

**Cummins
50 – 52 Diagonal Road
Pooraka
South Australia 5082**

**Parts phone: 08 8368 4358
Service phone: 08 8368 4308**

CONTENTS

1. SAFETY PRECAUTIONS	4
2. SPECIFICATIONS	6
3. COMPONENTS	7
4. PRE-OPERATION CHECKS	9
5. OPERATING PROCEDURES	13
6. WATTAGE INFORMATION	22
7. SPARK ARRESTER	24
8. MAINTENANCE SCHEDULE	25
9. "HOW-TO" MAINTENANCE	27
10. PREPARATION FOR STORAGE	29
11. TROUBLESHOOTING	30
12. WIRING DIAGRAM	31



1. SAFETY PRECAUTIONS

Please make sure you review each precaution carefully.

⚠ WARNING

Do not operate the generator near gasoline or gaseous fuel because of the potential danger of explosion or fire.

Do not fill the fuel tank with fuel while the engine is running. Do not smoke or use open flame near the fuel tank. Be careful not to spill fuel during refueling. If fuel is spilt, wipe it off and let dry before starting the engine.



⚠ WARNING

Do not place in flammables near the generator.

Be careful not to place fuel, matches, gunpowder, oily cloths, straw, trash, or any other in flammables near the generator.

⚠ WARNING

Do not operate the generator inside a room, cave, tunnel, or other insufficiently ventilated area. Always operate it in a well-ventilated area, otherwise the engine may become overheated, and the poisonous carbon monoxide gas contained in the exhaust gases will endanger human lives. Keep the generator at least 1 meter (3 feet) away from any structure or building during use.

If the generator must be used indoors, the area must be well-ventilated and extreme caution must be taken regarding the discharge of exhaust gases.

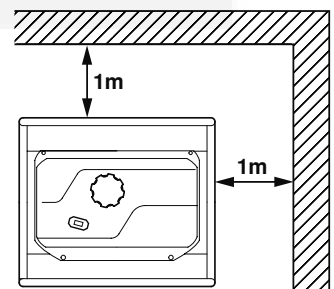
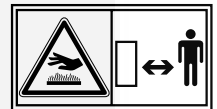

⚠ WARNING

Do not enclose the generator nor cover it with a box.

The generator has a built-in forced air cooling system, and may become overheated if it is enclosed. If generator has been covered to protect it from the weather during non use, be sure to remove it and keep it well away from the area during generator use.

⚠ WARNING

Operate the generator on a level surface.

It is not necessary to prepare a special foundation for the generator.

However, the generator will vibrate on an irregular surface, so choose a level place without surface irregularities.

If the generator is tilted or moved during operation, fuel may spill and / or the generator may tip over, causing a hazardous situation.

Proper lubrication cannot be expected if the generator is operated on a steep incline or slope. In such a case, piston seizure may occur even if the oil is above the upper level.

⚠ WARNING

Pay attention to the wiring or extension cords from the generator to the connected device.

If the wire is under the generator or in contact with a vibrating part, it may break and possibly cause a fire, generator burnout, or electric shock hazard.

Replace damaged or worn cords immediately.



⚠ WARNING

Do not operate in rain, in wet or damp conditions, or with wet hands.
The operator may suffer severe electric shock if the generator is wet due to rain or snow.

⚠ WARNING

If wet, wipe and dry it well before starting. Do not pour water directly over the generator, nor wash it with water.

⚠ WARNING

Be extremely careful that all necessary electrical grounding procedures are followed during each and every use. Failure to do so can be fatal.

⚠ WARNING

Do not contact the generator to a commercial power line. Connection to a commercial power line may short circuit the generator and ruin it or cause electric shock hazard. Use the transfer switch for connecting to domestic circuit.

**⚠ WARNING**

No smoking while handling the battery. The battery emits flammable hydrogen gas, which can explode if exposed to electric arcing or open flame. Keep the area well-ventilated and keep open flames/sparks away when handling the battery.

**⚠ WARNING**

Engine becomes extremely hot during and for some time after operation. Keep combustible materials well away from generator area. Be very careful not to touch any parts of the hot engine especially the muffler area or serious burns may result.

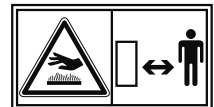
**⚠ WARNING**

Keep children and all bystanders at a safe distance from work areas.

⚠ WARNING

It is absolutely essential that you know the safe and proper use of the power tool or appliance that you intend to use. All operators must read, understand and follow the tool/appliance owners manual. Tool and appliance applications and limitations must be understood. Follow all directions given on labels and warnings. Keep all instruction manuals and literature in a safe place for future reference.

⚠ WARNING

Use only "LISTED" extension cords. When a tool or appliance is used outdoors, use only extension cords marked "For Outdoor Use". Extension cords, when not in use should be stored in a dry and well ventilated area.

⚠ WARNING

Always switch off generator's AC circuit breaker and disconnect tools or appliances when not in use, before servicing, adjusting, or installing accessories and attachments.

[CAUTION]

Make sure the engine is stopped before starting any maintenance, servicing or repair.
Make sure maintenance and repair of the generator set are performed by properly trained personnel only.

2. SPECIFICATIONS

MODEL		PX2900	PX3600	PX4800	
Generator	Type	Brush-less, self-exciting, 2-poles, single phase			
	Voltage regulating system	Condenser type			
	AC Output				
	Rated voltage-Frequency	V-Hz	120-60	120/240-60	240-50
	Rated output	VA (W)	2400	2900	3500
	Maximum output	VA (W)	2900	3600	4100
	Rated power factor		1.0		
	Safety device type		Fuse-less circuit breaker		
	DC Output				
	Rated voltage	V	12		
Rated current	A	8.3			
Safety device type		Fuse-less circuit breaker			
Engine	Model	EX17D	EX21D	EX27D	
	Type	ROBIN, Air-cooled, 4-stroke, OHC			
	Displacement	mL (cu.in.)	169 (10.31)	211 (12.87)	265 (16.17)
	Fuel		Automotive Unleaded Gasoline		
	Fuel tank capacity	L (U.S. gal)	12.8 (3.37)		16.7
	Rated continuous operation	hours	8.1	6.5	4.6
	Engine oil capacity	L (U.S. gal)	0.6 (0.15)		1.0 (0.26)
	Spark plug		BR-6HS (NGK) (Champion; RL86C)		
	Starting system		Recoil starter		Electric starter / Recoil
Dimension	Length	mm (in.)	580 (22.8)	605 (23.8)	650 (25.6)
	Width	mm (in.)	420 (16.5)	450 (17.7)	510 (20.1)
	Height	mm (in.)	480 (18.9)	500 (19.7)	540 (21.3)
Dry weight	kg (lb)	48 (106)	54 (119)	70 (154)	
Valve Clearance (Intake & Exhaust)	mm (in.)	0.12 ^{+0.03} / ₀ mm (0.0047 ^{+0.0012} / ₀ in.) Note : Adjust the valve clearance while the engine is cold.			
Emissions Durability Period (California only)	hours	500			

Specifications are subject to change without notice.

3. COMPONENTS

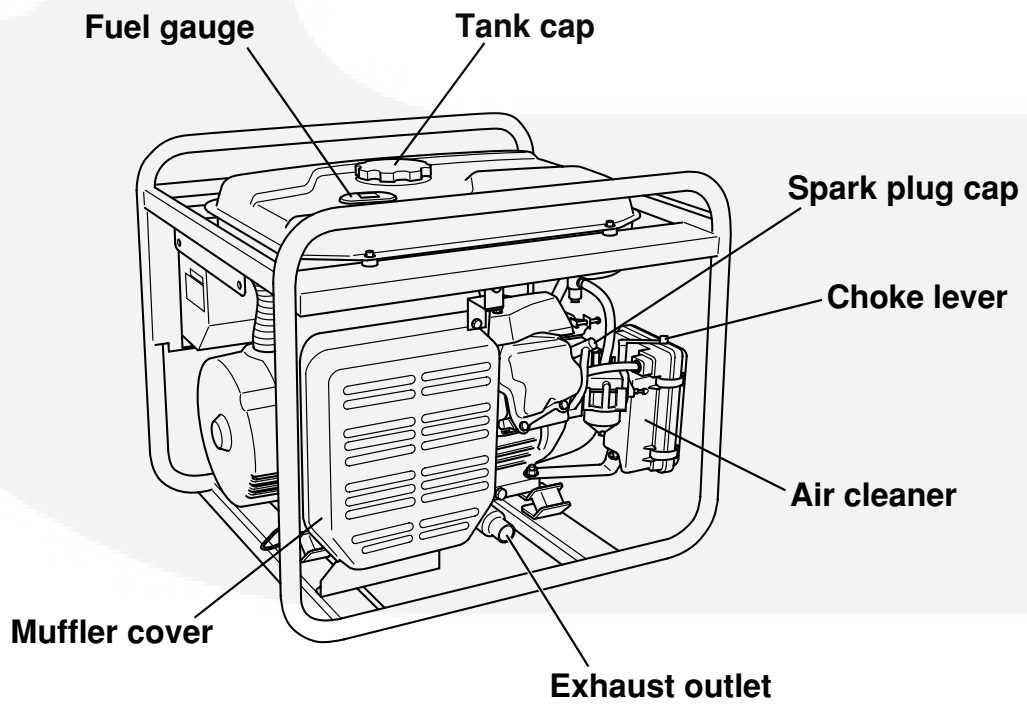
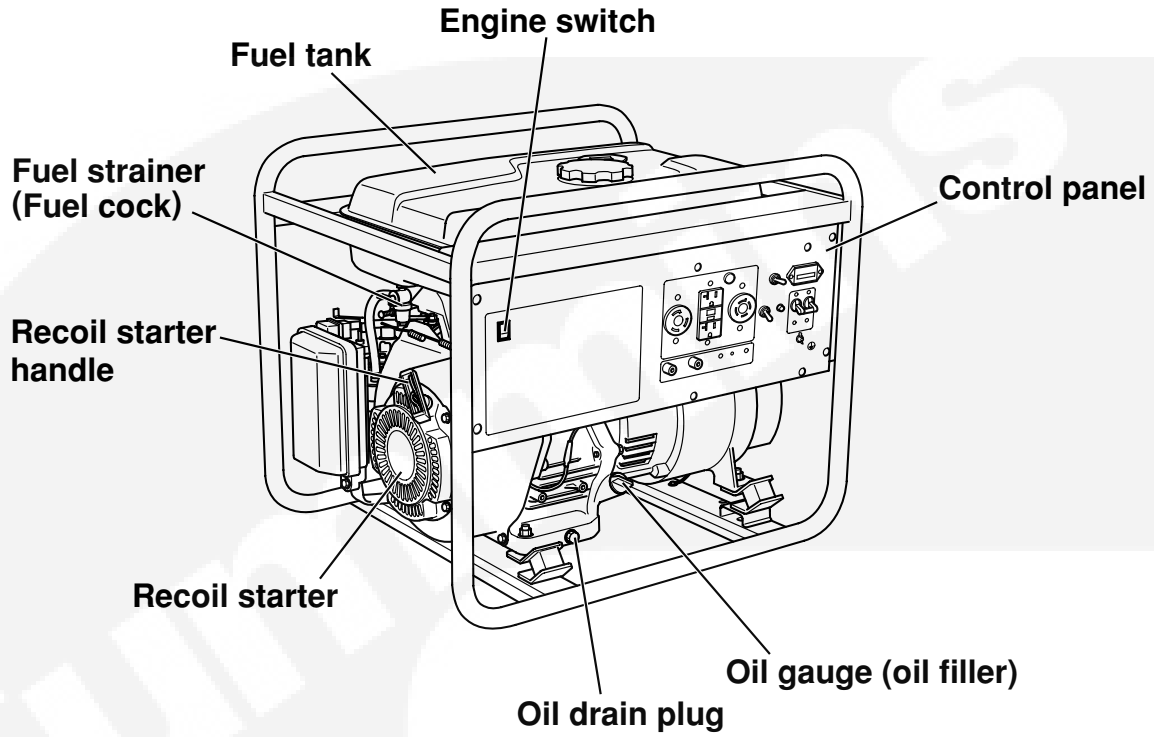

CONTROL PANEL

(PX4800 w/Starter motor)

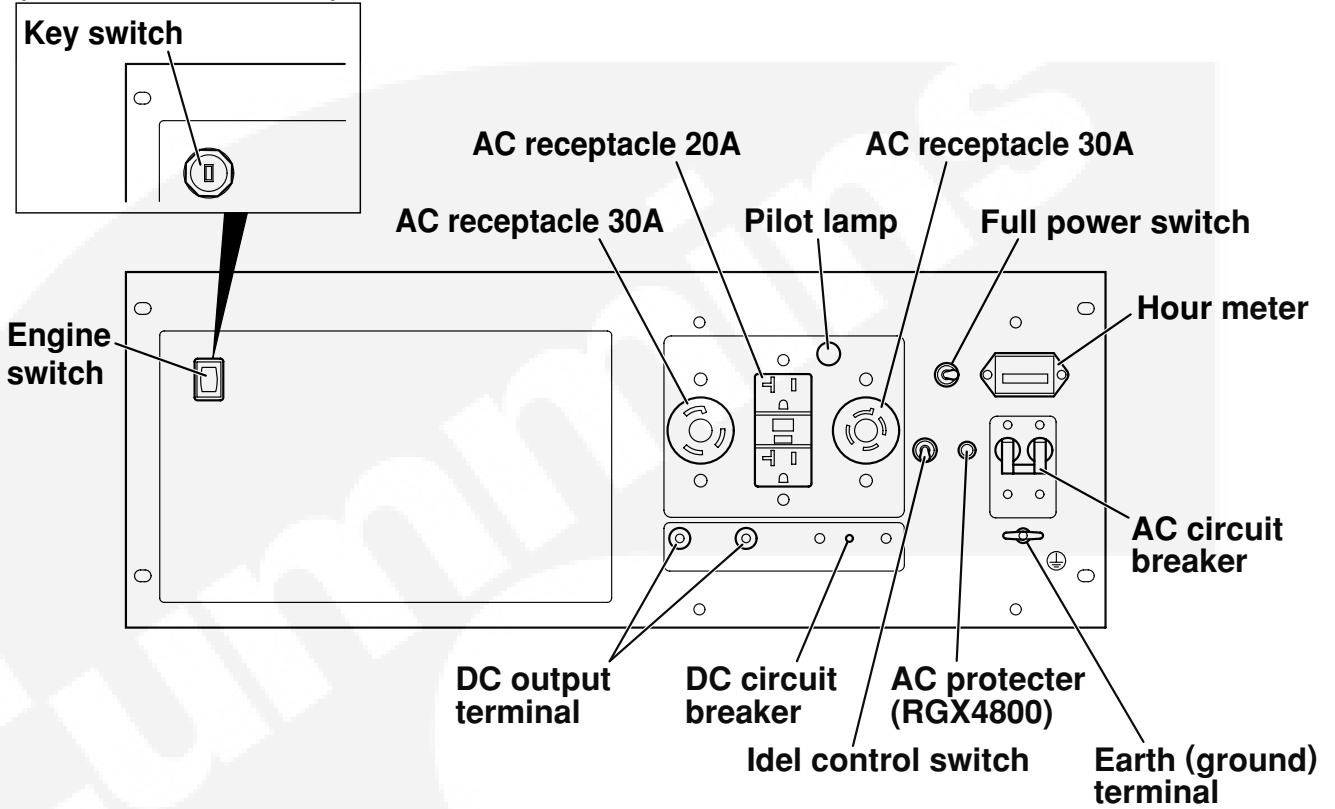

(PX2900)

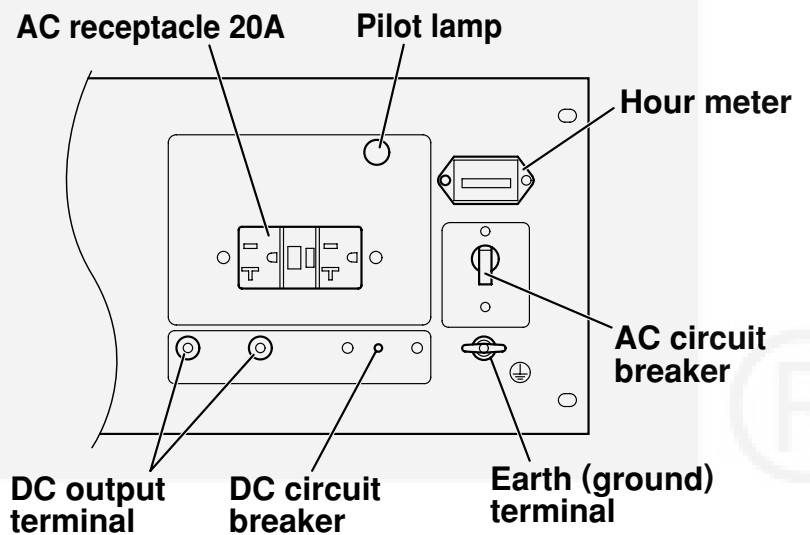

4. PRE-OPERATION CHECKS

CHECK ENGINE OIL

Before checking or refilling oil, be sure generator is located on stable and level surface with engine stopped.

- Remove oil filler cap and check the engine oil level.
- If oil level is below the lower level line, refill with suitable oil (see table) to upper level line. Do not screw in the oil filler cap when checking oil level.
- Change oil if contaminated. (See "How-To" Maintenance.)

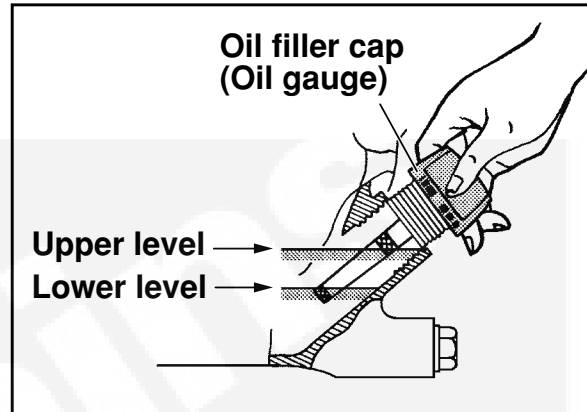

Oil capacity (Upper level) :	L (U.S. gal)
PX2900	0.6 (0.15)
PX3600	0.6 (0.15)
PX4800	1.0 (0.26)

Recommended engine oil :

Use 4-stroke automotive detergent oil of API service class **SE** or higher grade (**SG**, **SH** or **SJ** is recommended). **SAE 10W-30** or **10W-40** is recommended for general, all-temperature use. If single viscosity oil is used, select the appropriate viscosity for the average temperature in your area.

Single grade	5W						
	10W						
Multigrade				10W-30			
				10W-40			
Ambient temperature	-20	-10	0	10	20	30	40°C
	-4	14	32	50	68	86	104°F

CHECK ENGINE FUEL.

! WARNING

Do not refuel while smoking or near open flame or other such potential fire hazards. Otherwise fire accident may occur.

NOTE :

THIS ENGINE IS CERTIFIED TO OPERATE ON AUTOMOTIVE UNLEADED GASOLINE.

- Check fuel level at fuel level gauge.
- If fuel level is low, refill with unleaded automotive gasoline.
- Be sure to use the fuel filter screen on the fuel filter neck.

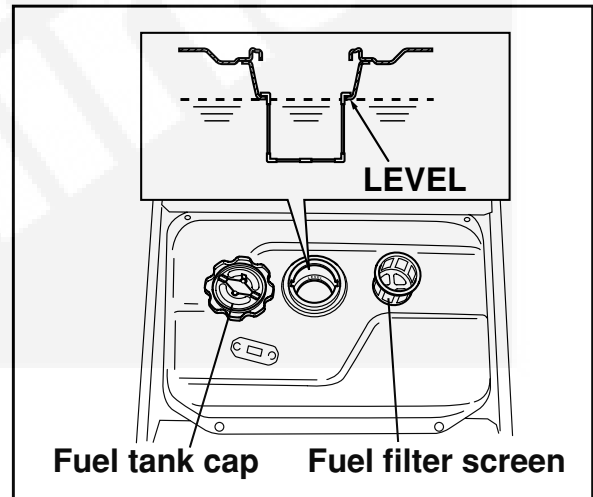

Fuel Amount up to "LEVEL" position	12.8 liters (3.37 U.S. gal)
--	--

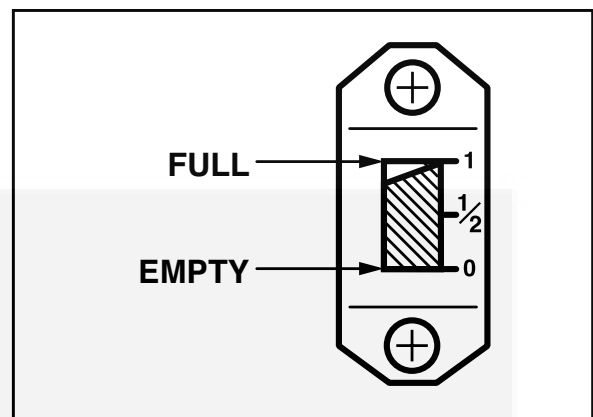

! WARNING

Make sure you review each warning in order to prevent fire hazard.

- Do not refill tank while engine is running or hot.
- Close fuel cock before refueling with fuel.
- Be careful not to admit dust, dirt, water or other foreign objects into fuel.
- Wipe off spilt fuel thoroughly before starting engine.
- Keep open flames away.

CHECKING COMPONENT PARTS

Check following items before starting engine:

- Fuel leakage from fuel hose, etc.
- Bolts and nuts for looseness.
- Components for damage or breakage.
- Generator not resting on or against any adjacent wiring.

CHECK GENERATOR SURROUNDINGS

⚠ WARNING

Make sure you review each warning in order to prevent fire hazard.

- Keep area clear of in flammables or other hazardous materials.
- Keep generator at least 3 feet (1 meter) away from buildings or other structures.
- Only operate generator in a dry, well ventilated area.
- Keep exhaust pipe clear of foreign objects.
- Keep generator away from open flame. No smoking!
- Keep generator on a stable and level surface.
- Do not block generator air vents with paper or other material.

BATTERY INSTALLATION (PX4800 w/Electric Starter)

Recommended Battery

Type ; Lead-acid battery

Capacity (Ah/5hr) ; 12V-21AH or more

Size ; Less than 185(L) x 125(W) x 160(H) mm

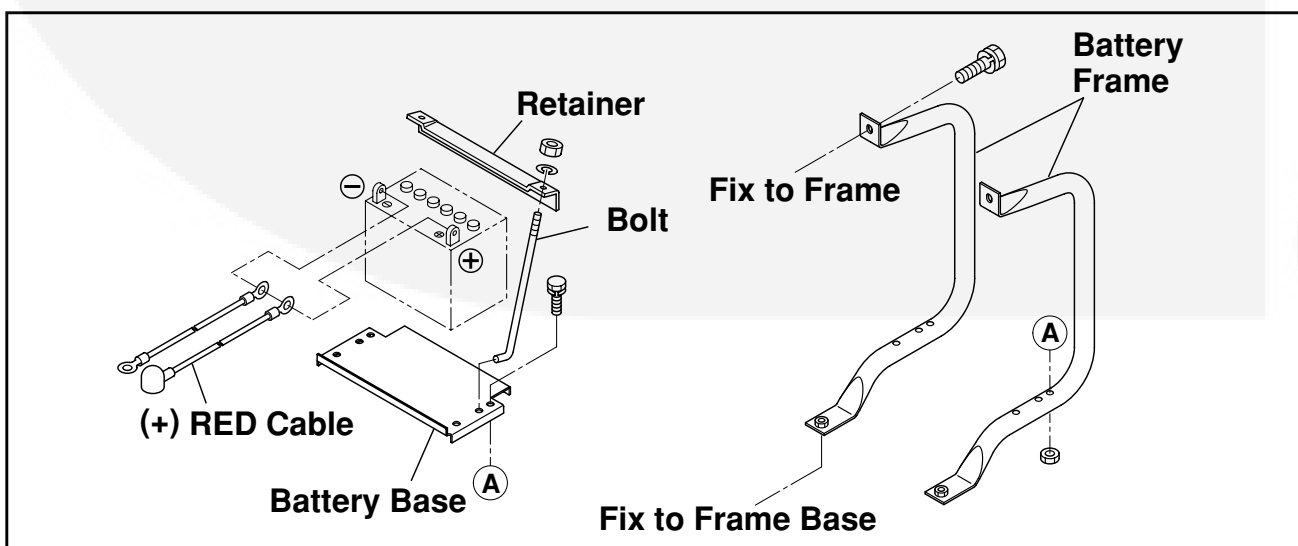

⚠ WARNING

Death, personal injury and/or property damage may occur unless instructions are followed carefully.

- Use battery of recommended capacity.
- Turn the starter switch to the "STOP" position when mounting or dismounting battery. When mounting battery, connect the positive (+) cable first and then the negative (-) cable to the battery. Be careful not to short battery cables. When dismounting battery, disconnect negative (-) cable first.

RED CABLE : To positive (+) terminal

BLACK CABLE : To negative (-) terminal

- Should the connection be made in incorrect manner, the generator will be broken.
- Tighten bolts and nuts on terminals securely so they will not be loosened by vibration.
- Disconnect battery cables when charging battery.

GROUNDING THE GENERATOR

- To ground the generator to the earth, connect the grounding lug of the generator to the grounding spike driven into the earth or to the conductor which has been already grounded to the earth.
- If such grounding conductor or grounding electrode is unavailable, connect the grounding lug of the generator to the grounding terminal of the using electric tool or appliance.

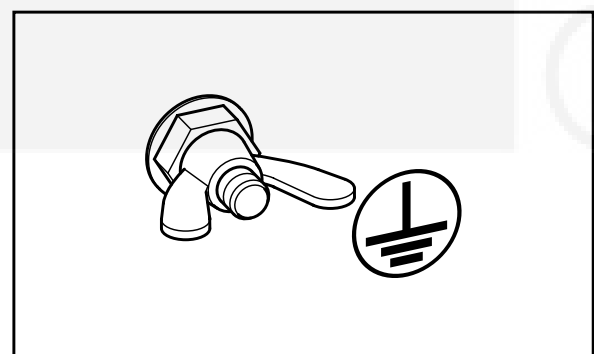
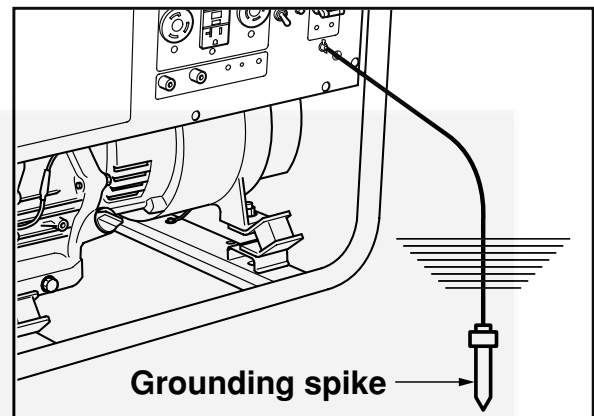

5. OPERATING PROCEDURES

STARTING THE GENERATOR

[CAUTION]

Check the oil level before each operations as outlined by the article "CHECK ENGINE OIL"

(a) Turn the Engine switch to the position "ON".

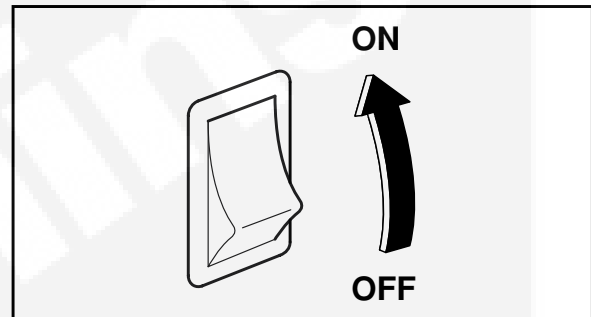

(b) Turn the AC circuit breaker to the position "OFF".

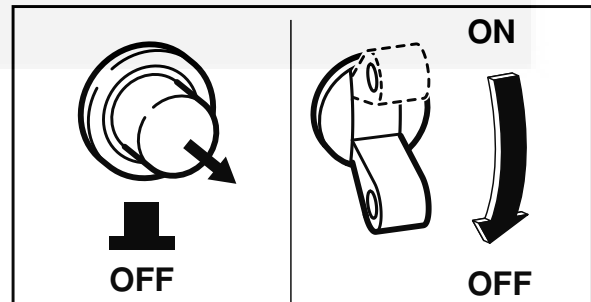

(c) Open the fuel cock.

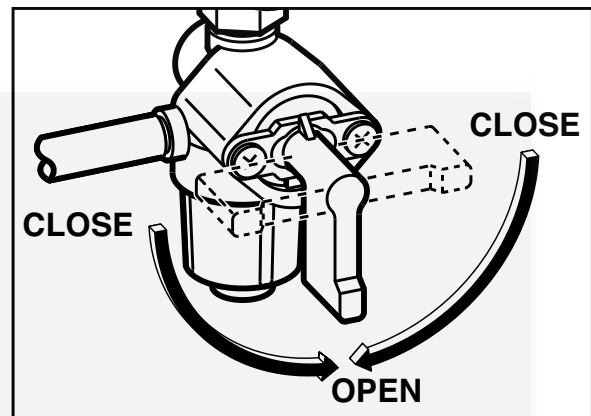

(d) Set choke lever to close if the engine is cold.

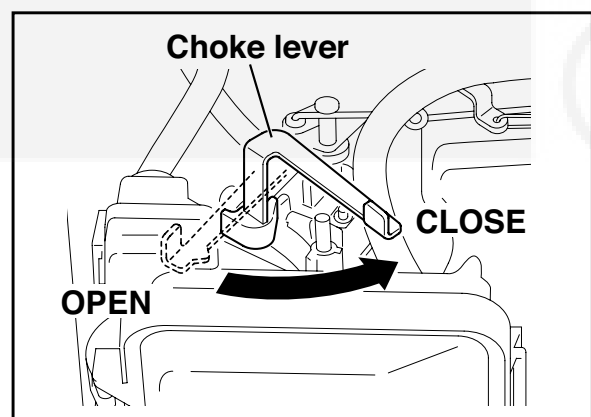

(e) Pull the starter handle slowly until passing the compression point (resistance will be felt), then return the handle to its original position and pull briskly.

- If the engine fails to start after several attempts, repeat above procedures with choke lever returned to "OPEN" position.
- Do not fully pull out the rope.
- After starting, allow the starter handle to return to its original position while still holding the handle.

(f) After the engine started, return the choke lever gradually to "OPEN" position.

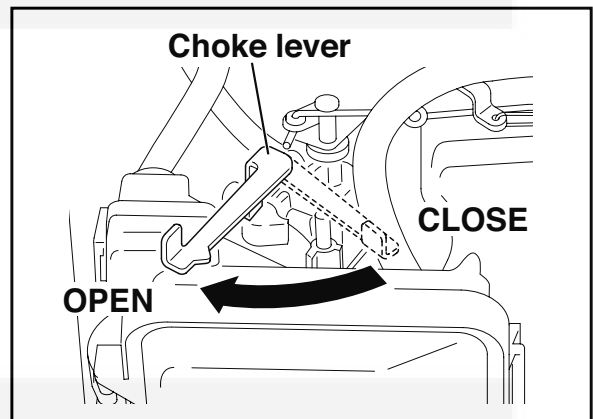
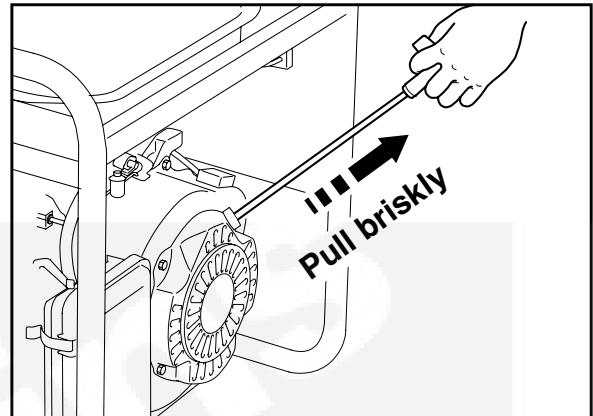

(g) Warm up the engine without a load for a few minutes.



USING ELECTRIC POWER

⚠ WARNING

- Make sure that the appliance is switched OFF before connecting it to the generator.
- Do not move the generator while it is running.
- Be sure to ground the generator if the connected appliance is grounded. Failure to ground unit may lead to electrical shock.

(1) AC APPLICATION

(a) Make sure the pilot lamp is turned on.

(b) Turn off the switch (es) of the electrical appliance (s) before connecting to the generator.

(c) Insert the plug (s) of the electrical appliance(s) into the receptacle.

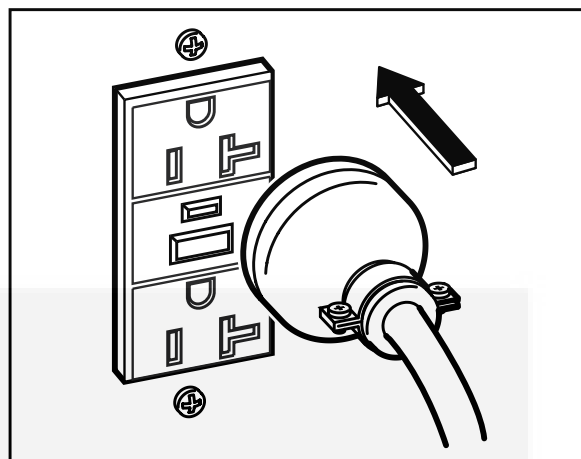

- Check the amperage of the receptacles used referring to **TABLE 1**, and be sure not to take a current exceeding the specified amperage.
- Be sure that the total wattage of all appliances dose not exceed the rated output of the generator.





Style	Ampere	Receptacle	AC plug	Description
	up to 20A	NEMA 5-20R	NEMA 5-20P	GFCI (Ground Fault Circuit Interrupter) Receptacle, duplex (REC1)
	up to 20A	NEMA L14-20R	NEMA L14-20P	Locking Receptacle (REC2)
	up to 30A	NEMA L5-30R	NEMA L5-30P	Locking Receptacle (REC3)
	up to 30A	NEMA L14-30R	NEMA L14-30P	Locking Receptacle (REC4)

TABLE 1

⚠ WARNING

- To take power out from the **TWIST LOCK RECEPTACLE**, insert the plug into the receptacle, and turn it clockwise to the lock position.
- Be sure to ground the generator if the connected electrical device is grounded.

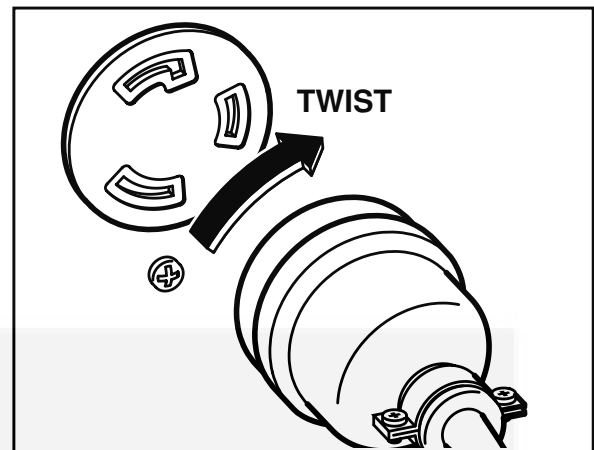

NOTE :

When the AC circuit breaker turns off during operation, the generator is overloaded or the appliance is defective. Stop the generator immediately, check the appliance and / or generator for overloading or detect and have repaired as necessary by Cummins Generator dealer or service shop.

[CAUTION]

The duplex 120V receptacle is protected by a GFCI (Ground Fault Circuit Interrupter). GFCI shuts off the output current from the duplex 120V receptacle when a ground fault occurs in the generator or the appliance. Please note that other receptacles are not protected by GFCI.

(d) Turn the AC circuit breaker to the position "ON".

(e) Turn on the switch of the appliance.

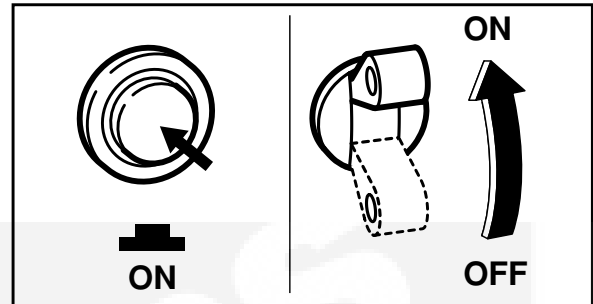

GFCI RECEPTACLE

After starting the engine, check the GFCI for proper functioning by the following test procedure.

- Push blue TEST button, The red RESET button will pop out exposing the word TRIP. Power is now off at the outlets protected by the GFCI, indicating that the device is functioning properly.
- If TRIP does not appear when testing, do not use the generator. Call a qualified electrician.
- To restore power, push RESET button.

⚠ WARNING

If the RESET button pops out during operation, stop the generator immediately and call a qualified electrician for checking generator and the appliances.



FULL POWER SWITCH (Except PX2900)

Select the voltage using the FULL POWER SWITCH in accordance with the electrical appliance.

Refer to **TABLE 2**.

[CAUTION]

Change the FULL POWER SWITCH after turning the AC circuit breaker to "OFF".

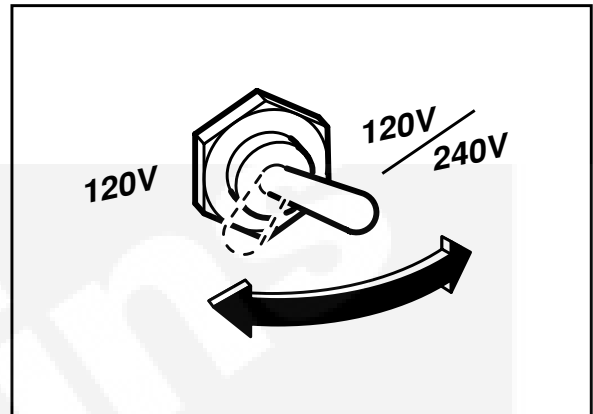

Switch position	Lower Voltage Receptacle	Higher Voltage Receptacle
120V	Activated full rated output	N.A
120/240V	Activated half of rated output	Activated full rated output

TABLE 2

IDLE CONTROL SWITCH (Except PX2900)

IDLE CONTROL SWITCH automatically reduces engine speed when load is OFF, and automatically increases engine speed to rated r.p.m. when load is ON.

IDLE CONTROL SWITCH provides fuel economy and low noise operation at no-load running.

(1) HOW TO USE IDLE CONTROL SWITCH

- Start the engine with IDLE CONTROL SWITCH off.

NOTE :

Warm up the engine without a load for a few minutes.

- Turn IDLE CONTROL SWITCH on.

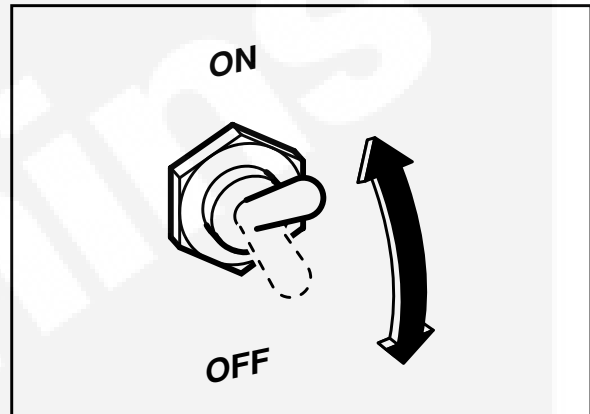

(2) CHECKING THE OPERATION

When IDLE CONTROL SWITCH does not operate normally, please check following :

- Overloaded ?
Please make it sure that the generator is not overload.

NOTE :

Most induction loads such as electric motors require three to five times more wattage than their ratings during starting.

This starting wattage should not exceed the rated output of the generator for proper operation of IDLE CONTROL SWITCH.

- Turn IDLE CONTROL SWITCH off when the IDLE CONTROL SWITCH does not work normally under the rated output.

NOTE :

The IDLE CONTROL SWITCH may not operate when the applied load is under 40W. In such cases turn the IDLE CONTROL SWITCH off.

(3) STOPPING THE ENGINE

- Turn off the switch of load.
- Switch off generator's AC breaker.
- Disconnect tool or appliance.
- Turn the IDLE CONTROL SWITCH off.
- Turn the STOP SWITCH to the position "O" (OFF).

NOTE :

Allow the engine about 3 minutes to cool down at no-load before stopping.

(2) DC APPLICATION

The DC terminal is used only for charging 12 volt batteries.

It provides up to 12V-8.3A (100W) of maximum power.

CONNECTION OF CABLE :

- Connect positive (red) terminal on generator to positive (+) terminal on battery.
- Connect negative (black) terminal on generator to negative (-) terminal on battery.
- Both AC and DC output can be used at the same time if the total output is within rated output of the generator.

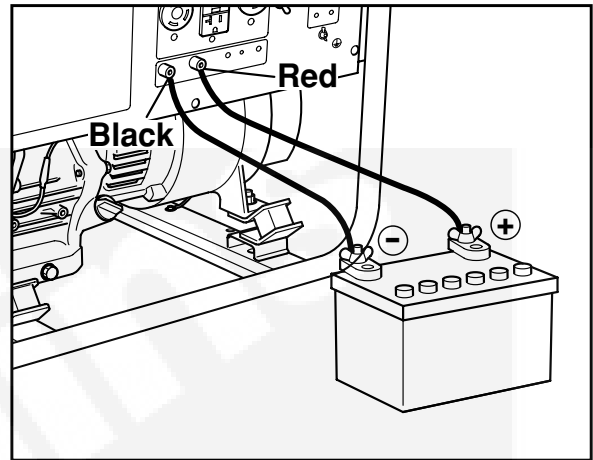

SAFETY PRECAUTIONS WHILE CHARGING

- An explosive hydrogen gas is discharged through vent holes in the battery during the charging process. Do not allow spark or open flame around the generator or battery during the charging process.
- Electrolyte fluid can burn eyes and clothing. Be extremely careful to avoid contact. If injured, wash the affected area immediately with large quantities of water and consult a doctor for treatment.
- When charging a large capacity battery or totally discharged battery, excessive current may force the DC breaker to turn off. In such cases, use a battery charger to charge a large battery with AC output.
- Battery defects may cause the DC breaker to turn off. Check the battery before replacing the DC breaker.

STOPPING THE GENERATOR

- (a) Turn off the power switch of the electric equipment and unplug the cord from receptacle of the generator.
- (b) Turn the AC circuit breaker to the "OFF" position.
- (c) Allow the engine about 3 minutes to cool down at no-load before stopping.
- (d) Turn the Engine switch to the position "OFF".
- (e) Close the fuel cock.

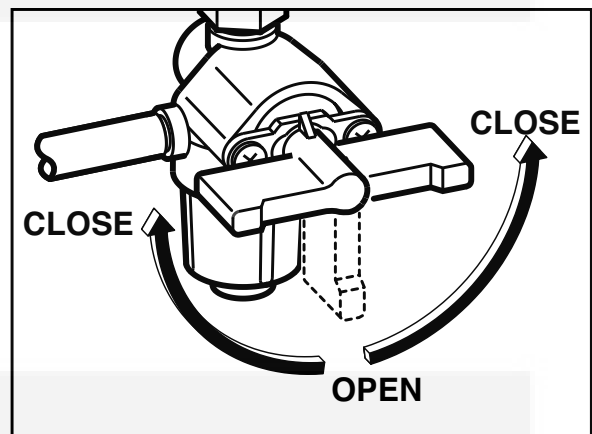
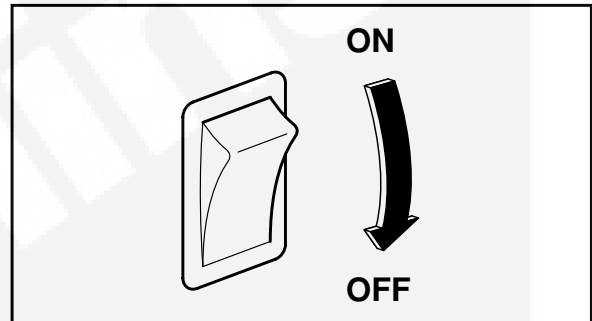
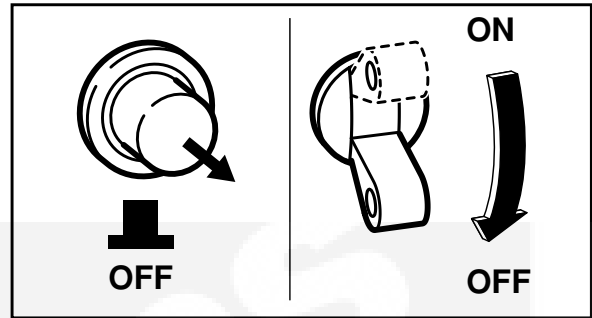

OIL SENSOR

- (a) The oil sensor detects the fall in oil level in the crankcase and automatically stops the engine when the oil level falls below a predetermined level.
- (b) When engine has stopped automatically, switch off generator's AC circuit breaker, and check the oil level. Refill engine oil to the upper level as instructed on page 6 and restart the engine.
- (c) If the engine does not start by usual starting procedures, check the oil level.

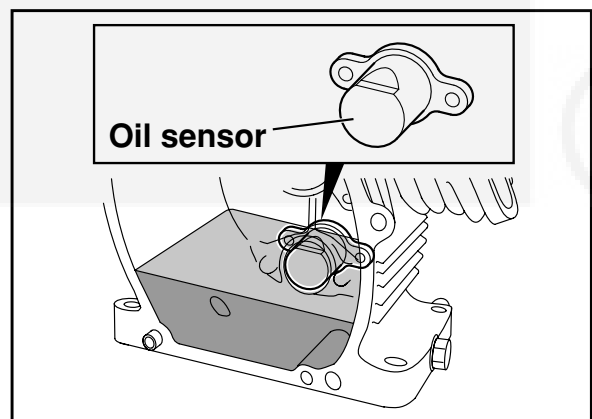

6. WATTAGE INFORMATION

Some appliances need a "surge" of energy when starting.

This means that the amount of electrical power needed to start the appliance may exceed the amount needed to maintain its use.

Electrical appliances and tools normally come with a label indicating voltage, cycles / Hz, amperage (amps) and electrical power needed to run the appliance or tool.

Check with your nearest dealer or service center with questions regarding power surge of certain appliances or power tools.

- Electrical loads such as incandescent lamps and hot plates require the same wattage to start as is needed to maintain use.
- Loads such as fluorescent lamps require 1.2 to 2 times the indicated wattage during start-up.
- Loads for mercury lamps require 2 to 3 times the indicated wattage during start-up.
- Electrical motors require a large starting current. Power requirements depend on the type of motor and its use. Once enough "surge" is attained to start the motor, the appliance will require only 50% to 30% of the wattage to continue running.
- Most electrical tools require 1.2 to 3 times their wattage for running under load during use. For example, a 5,000 watt generator can power a 1800 to 4000 watt electrical tool.
- Loads such as submersible pumps and air compressors require a very large force to start. They need 3 to 5 times the normal running wattage in order to start. For example, a 5,000 watt generator would only be able to drive a 1,000 to 1,700 watt pump.

NOTE :

The following wattage chart is general guide only. Refer to your specific appliance for correct wattage.

To determine the total wattage required to run a particular electrical appliance or tool, multiply the voltage figure of the appliance/tool by the amperage (amps) figure of same. The voltage and amperage (amps) information can be found on a name plate which is normally attached to electrical appliances and tools.

Applications	Applicable Wattage (W)		
	PX2900	PX3600	PX4800
	60Hz		
Incandescent lamp, Heater	2400	2900	4100
Fluorescent lamp, Electric tool	1200	1500	2100
Mercury lamp	900	1100	1500
Pump, Compressor	550	650	950

VOLTAGE DROP IN ELECTRIC EXTENSION CORDS

When a long electric extension cord is used to connect an appliance or tool to the generator, a certain amount of voltage drop or loss occurs in the extension cord which reduces the effective voltage available for the appliance or tool.

The chart below has been prepared to illustrate the approximate voltage loss when an extension cord of 300 feet (approx. 100 meters) is used to connect an appliance or tool to the generator.

Nominal cross section	A.W.G.	Allowable current	No. of strands / strands dia.	Resistance	Current Amp.							Voltage drop
					1A	3A	5A	8A	10A	12A	15A	
mm ²	No.	A	No./mm	Ω/100m	1A	3A	5A	8A	10A	12A	15A	
0.75	18	7	30/0.18	2.477	2.5V	8V	12.5V	—	—	—	—	
1.27	16	12	50/0.16	1.486	1.5V	5V	7.5V	12V	15V	18V	—	
2.0	14	17	37/0.26	0.952	1V	3V	5V	8V	10V	12V	15V	
3.5	12 to 10	23	45/0.32	0.517	—	1.5V	2.5V	4V	5V	6.5V	7.5V	
5.5	10 to 8	35	70/0.32	0.332	—	1V	2V	2.5V	3.5V	4V	5V	



7. SPARK ARRESTER

In a dry or wooded area, it is recommendable to use the product with a spark arrester. Some areas require the use of a spark arrester. Please check your local laws and regulations before operating your product.

The spark arrester must be cleaned regularly to keep it functioning as designed. A clogged spark arrester :

- Prevents the flow of exhaust gas
- Reduces engine output
- Increases fuel consumption
- Makes starting difficult

If the engine has been running, the muffler and the spark arrester will be very hot. Allow the muffler to cool before cleaning the spark arrester.

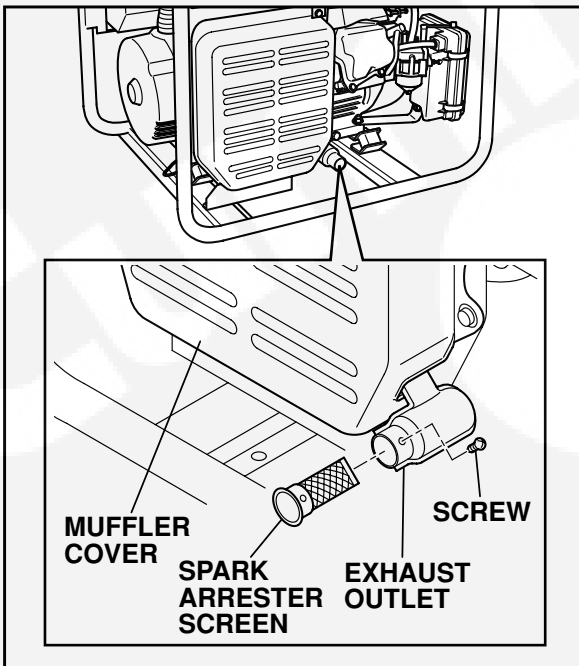

How to remove the spark arrester

1. Remove the flange bolts from the muffler cover and remove the muffler cover.
2. Remove the special screw from the spark arrester and remove the spark arrester from the muffler.

Clean the spark arrester screen

Use a brush to remove carbon deposits from the spark arrester screen. Be careful to avoid damaging the screen.

The spark arrester must be free of breaks and holes. Replace the spark arrester if it is damaged.

Install the spark arrester, and muffler protector in the reverse order of disassembly.

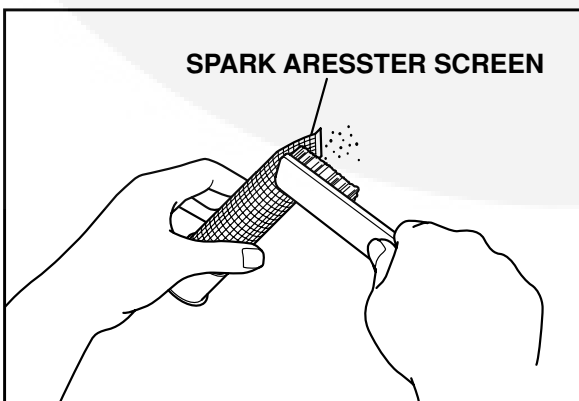

8. MAINTENANCE SCHEDULE

MAINTENANCE, REPLACEMENT, OR REPAIR OF THE EMISSION CONTROL DEVICES AND SYSTEMS MAY BE PERFORMED BY ANY NONROAD ENGINE REPAIR ESTABLISHMENT OR INDIVIDUAL.

DAILY INSPECTION

Before running the generator, check the following service items:

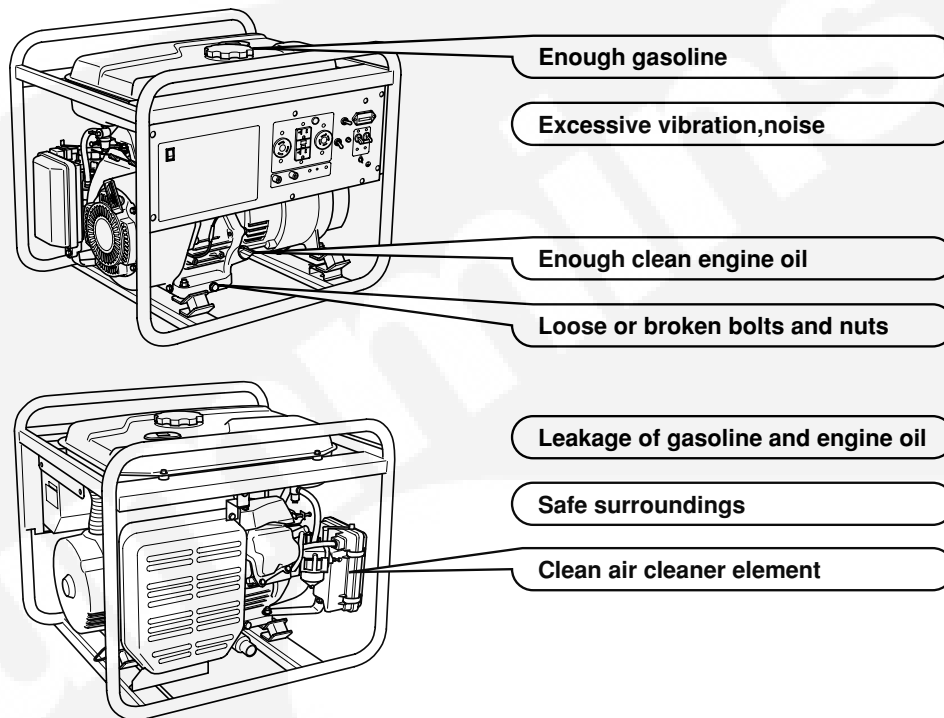

PERIODIC MAINTENANCE

Periodic maintenance is vital to safe and efficient operation of your generator. Check the table below for periodic maintenance intervals.

IT IS ALSO NECESSARY FOR THE USER OF THIS GENERATOR TO CONDUCT THE MAINTENANCE AND ADJUSTMENTS ON THE EMISSION-RELATED PARTS LISTED BELOW TO KEEP THE EMISSION CONTROL SYSTEM EFFECTIVE.

The emission control system consists of the following parts :

- | | | |
|---|--|--|
| (1) Carburetor and internal parts | (4) Air cleaner elements | (8) Exhaust manifold, if applicable |
| (2) Cold start enrichment system, if applicable | (5) Spark plug | (9) Hoses, belts, connectors, and assemblies |
| (3) Intake manifold, if applicable | (6) Magneto or electronic ignition system | |
| | (7) Spark advance/retard system, if applicable | |

The maintenance schedule indicated in the table is based on the normal generator operation. Should the generator be operated in extremely dusty condition or in heavier loading condition, the maintenance intervals must be shortened depending on the contamination of oil, clogging of filter elements, wear of parts, and so on.

Periodic Maintenance Schedule table

Maintenance Items	Every 8 hours (Daily)	Every 50 hours (Weekly)	Every 200 hours (Monthly)	Every 500 hours	Every 1000 hours
Clean generator and check bolt and nuts	● (Daily)				
Check and refill engine oil	● (Refill daily up to upper level)				
Change engine oil (*Note1)	● (Initial 20 hours)	● (Every 100 hours)			
Clean spark plug		● (Every 100 hours)			
Clean air cleaner		●			
Clean spark arrester		● (Every 100 hours)			
Replace air cleaner element			●		
Clean fuel filter			●		
Clean and adjust spark plug and electrodes			●		
Replace spark plug				●	
Remove carbon from cylinder head (*Note 2)				●	
Check and adjust valve clearance (*Note 2)				●	
Clean and adjust carburetor (*Note 2)				●	
Clean and replace carbon brushes				●	
Replace fuel lines					● (Yearly)
Overhaul engine (*Note 2)					●
Check AC receptacles	● (Daily)				
Check DC terminal	● (Daily)				
Check engine switch	● (Daily)				
Check rotor					●
Check stator					●
Replace engine mount					●

*Note: 1. Initial oil change should be performed after first twenty (20) hours of operation. Thereafter change oil every hundred (100) hours. Before changing oil, check for a suitable way to dispose of old oil. Do not pour it down into sewage drains, onto garden soil or into open streams. Your local zoning or environmental regulations will give you more detailed instructions on proper disposal.

*Note: 2. As to the procedures for these items, please refer to the SERVICE MANUAL or consult your nearest service dealer.

9. "HOW-TO" MAINTENANCE

ENGINE OIL CHANGE

- Change engine oil every 100 hours.
(For new engine, change oil after 20 hours.)
 - (a) Drain oil by removing the drain plug and the oil filler cap while the engine is warm.
 - (b) Reinstall the drain plug and fill the engine with oil until it reaches the upper level on the oil filler cap.
-
- Use fresh and high quality lubricating oil to the specified level as directed on page 6. If contaminated or deteriorated oil is used or the quantity of the engine oil is not sufficient, the engine damage will result and its life will be greatly shortened.

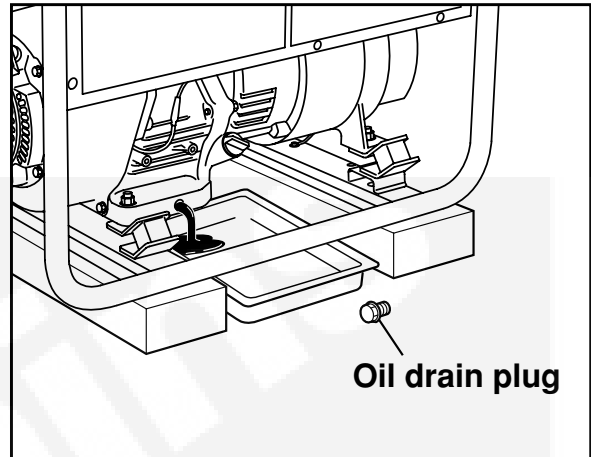

SERVICING THE AIR CLEANER

Maintaining an air cleaner in proper condition is very important.

Dirt induced through improperly installed, improperly serviced or inadequate elements damages and wears out engines. Keep the element always clean.

- (a) Unhook the cover and remove the cleaner element.
- (b) Urethane form : Wash the element with fresh water. Squeeze out the water then dry the element.
(Do not twist.)

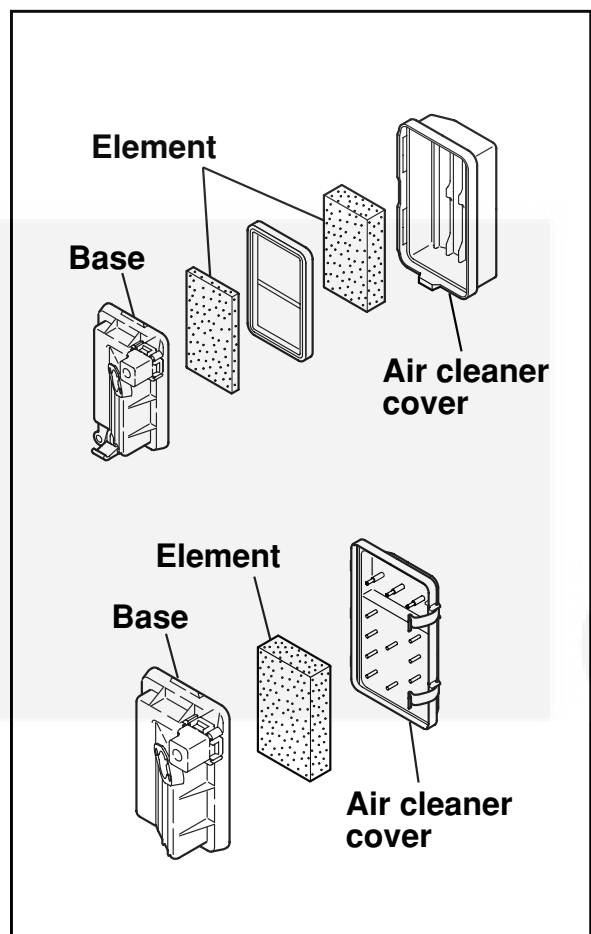

CLEANING AND ADJUSTING SPARK PLUG

- (a) If the plug is contaminated with carbon, remove it using a plug cleaner or wire brush.
- (b) Adjust the electrode gap to 0.6 to 0.7 mm (0.024 to 0.028 in.).

Spark plug :
BR-6HS (NGK) or RL86C (CHAMPION)

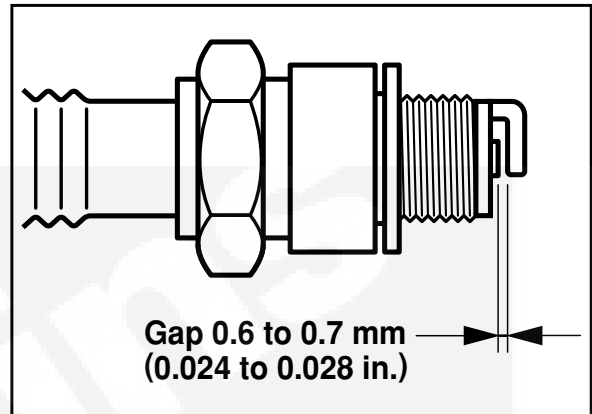

CLEANING FUEL STRAINER

Dirt and water in the fuel are removed by the fuel strainer.

- (a) Remove the strainer cup and throw away water and dirt.
- (b) Clean the screen and strainer cup with gasoline.
- (c) Tightly fasten the cup to main body, making sure to avoid fuel leak.

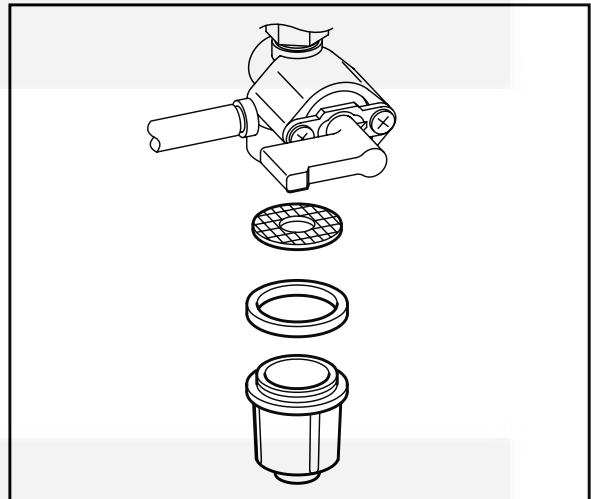

HIGH ALTITUDE ENGINE OPERATION

- Please have an authorized Cummins Generator service dealer modify this engine if it is to be run continuously above 5,000 feet (1,500 meters). Failure to do so, may result in poor engine performance, spark plug fouling, hard starting, and increased emissions.
- Carburetor modification by an authorized Cummins Generator service dealer will improve performance and allow that this engine meets EPA (Environmental Protection Agency) and California ARB (Air Resources Board) emission standards throughout its useful life.
- An engine converted for high altitudes can not be run at 5,000 feet or lower. In doing so, the engine will overheat and cause serious engine damage. Please have an authorized Cummins Generator service dealer restore high altitude modified engines to the original factory specification before operating below 5,000 feet.

10. PREPARATION FOR STORAGE

The following procedures should be followed prior to storage of your generator for periods of 6 months or longer.

- Drain fuel from fuel tank carefully by disconnecting the fuel line. Gasoline left in the fuel tank will eventually deteriorate making engine-starting difficult.
- Remove the carburetor float chamber and also drain the carburetor.
- Change engine oil.
- Check for loose bolts and screws, tighten them if necessary.

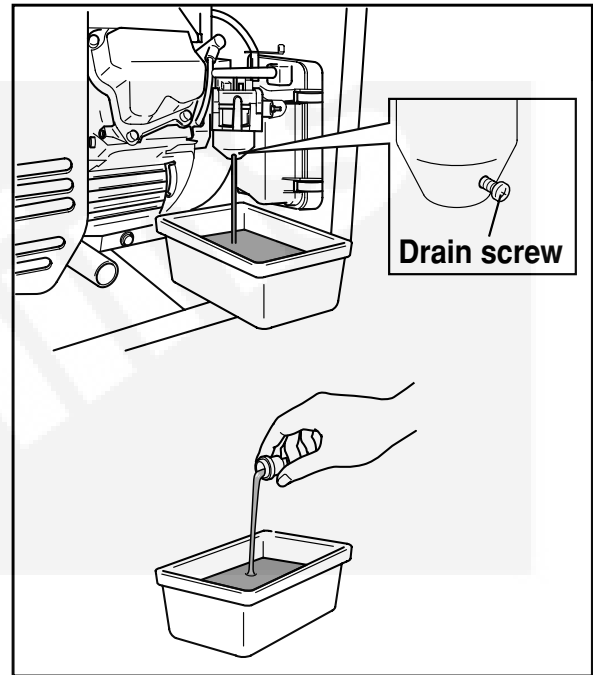

- Clean generator thoroughly with oiled cloth. Spray with preservative if available. **NEVER USE WATER TO CLEAN GENERATOR !**
- Pull starter handle until resistance is felt, leaving handle in that position.
- Store generator in a well ventilated, low humidity area.



11. TROUBLESHOOTING

When generator engine fails to start after several attempts, or if no electricity is available at the output socket, check the following chart. If your generator still fails to start or generate electricity, contact your nearest Cummins Generator dealer or service shop for further information or corrective procedures.

When Engine Fails to Start :

Check if choke lever is in its proper position.		Set the choke lever to "CLOSE" position.
Check if fuel cock is open.	↔	If closed, open fuel cock.
Check fuel level.		If empty, refill fuel tank making sure not to overfill.
Check if engine switch is in OFF.		Turn engine switch to ON.
Check to make sure generator is not connected to an appliance.		If connected, turn off the power switch on the connected appliance and unplug.
Check spark plug for loose spark plug cap.	↔	If loose, push spark plug cap back into place.
Check spark plug for contamination.		Remove spark plug and clean electrode.

When No Electricity Is Generated at Receptacle :

Check to make sure AC circuit breaker is in the "ON" position.	↔	After making sure that the total wattage of the electrical appliance is within permissible limits and there are no defects in the appliance, turn the AC circuit breaker to the "ON" position. If breakers continue to actuate, consult your nearest servicing dealer.
Check AC receptacle and DC terminals for loose connection.		Secure connection if necessary.
Check to see if engine starting was attempted with appliances already connected to generator.	↔	Turn off switch on the appliance, and disconnect cable from receptacle. Reconnect after generator has been started properly.

12. WIRING DIAGRAM

PX2900 (60Hz-120)

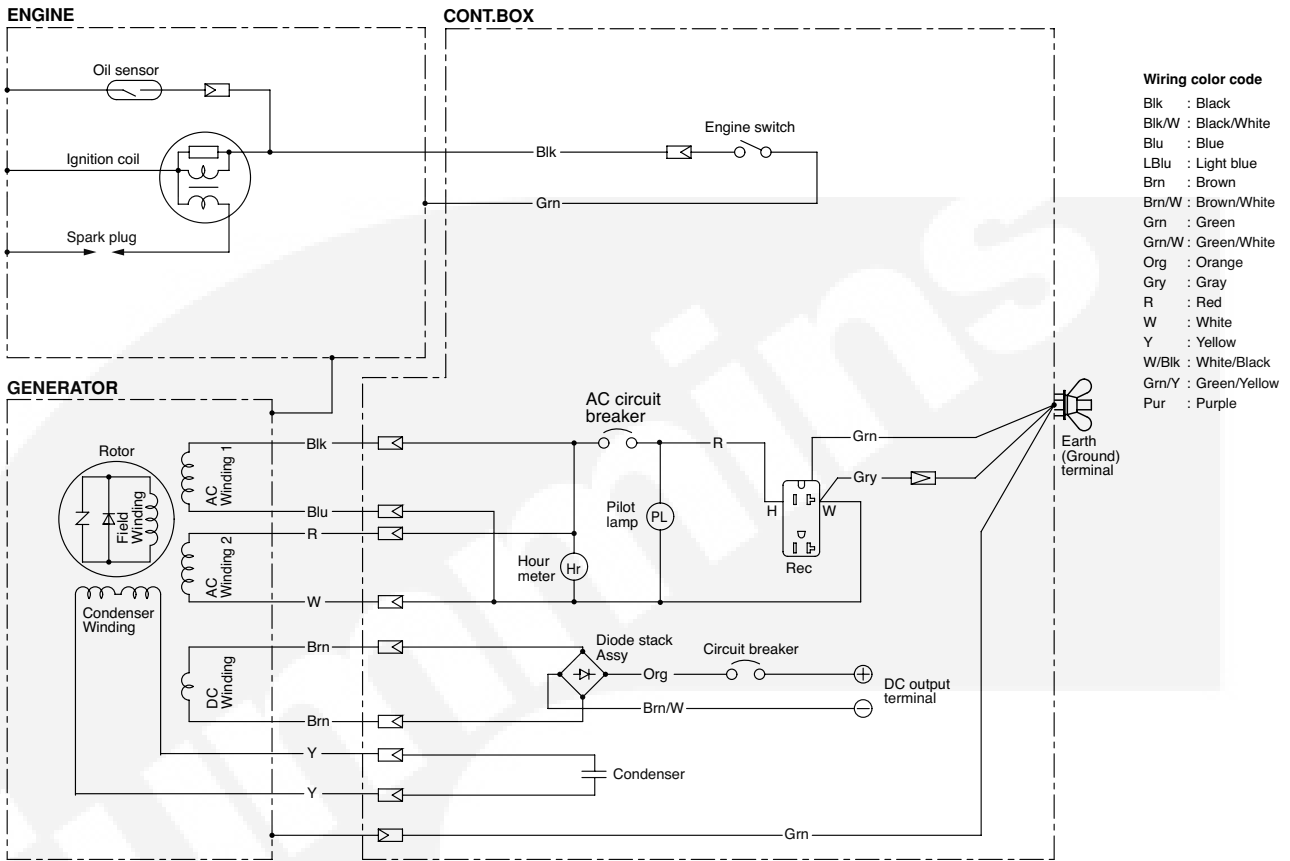

PX3600 (60Hz-120/240V)

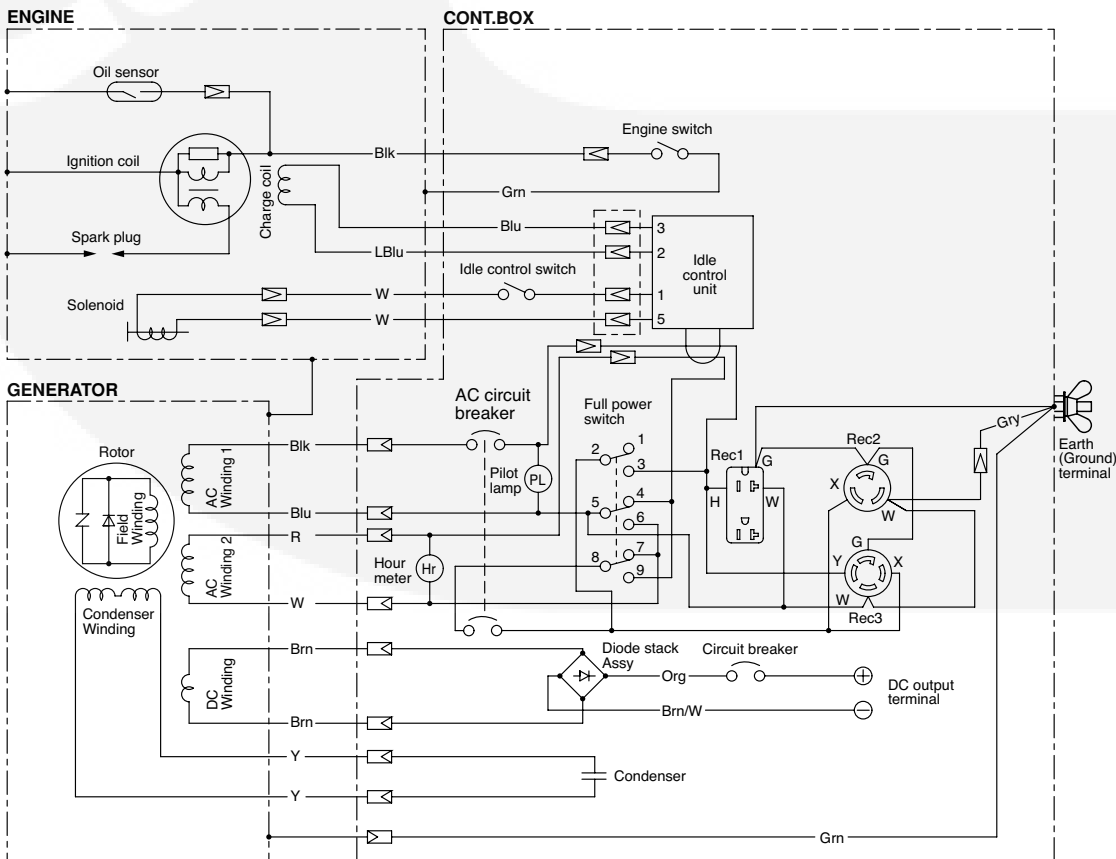

PX4800 (60Hz-120/240V)

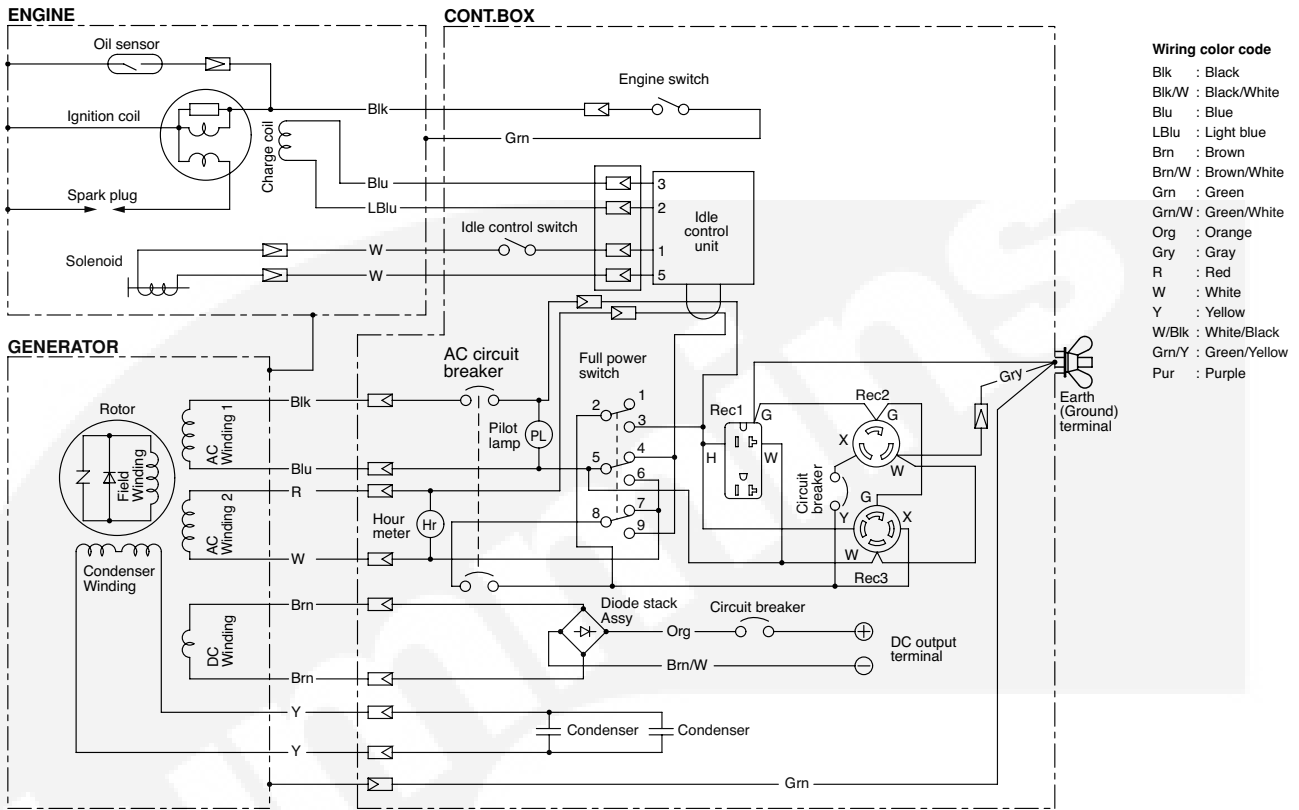

PX4800[w / Starter motor] (60Hz-120/240V)

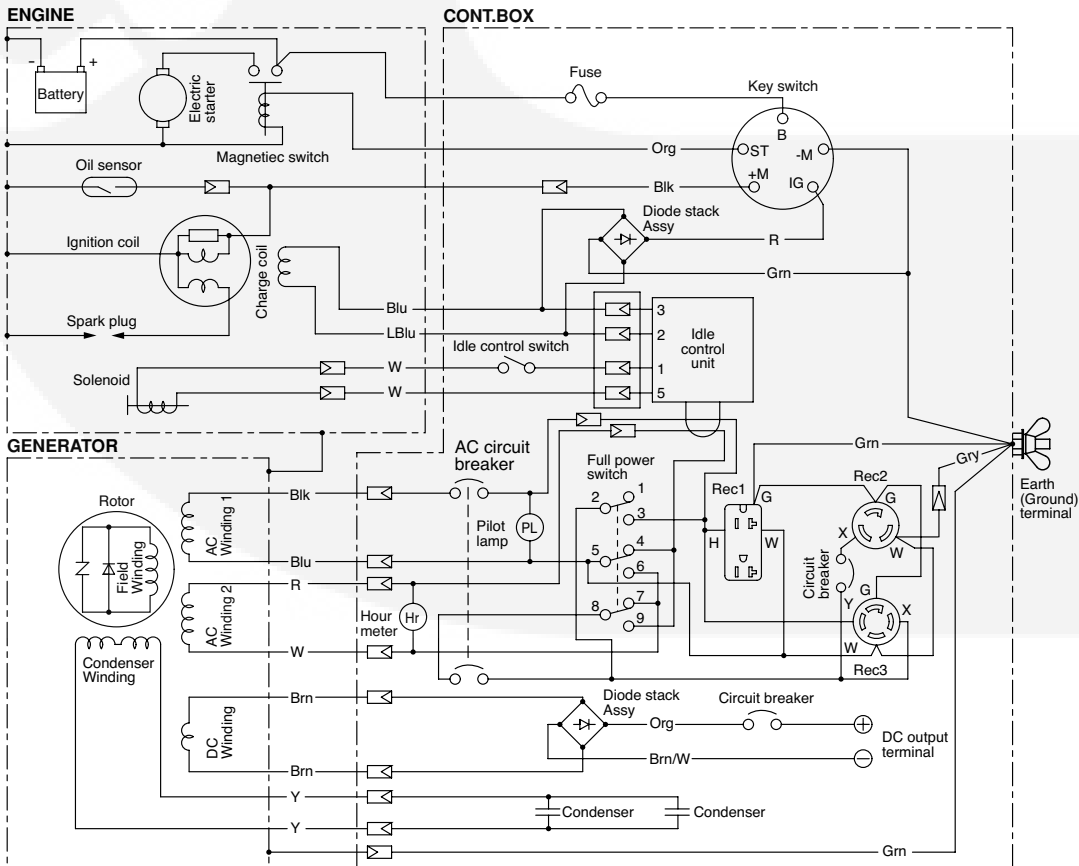

NOTES



NOTES



NOTES



NOTES



Cummins

Cummins **Onan**

Cummins Power Generation

1400 73rd Ave. NE
Minneapolis, MN 55432 USA

Phone 1 763 574 5000

Toll-free 1 800 888 6626

Fax 1 763 574 5298

Email www.cumminsonan.com/contact

www.cumminsonan.com

Cummins®, Onan®, the "C" logo, and "Performance you rely on." are trademarks of Cummins Inc.

©2008 Cummins Power Generation, Inc. All rights reserved.

