

PARTS MANUAL

INVERTER GENERATOR

P4300ie



Cummins **Onan**



MANUAL LAYOUT

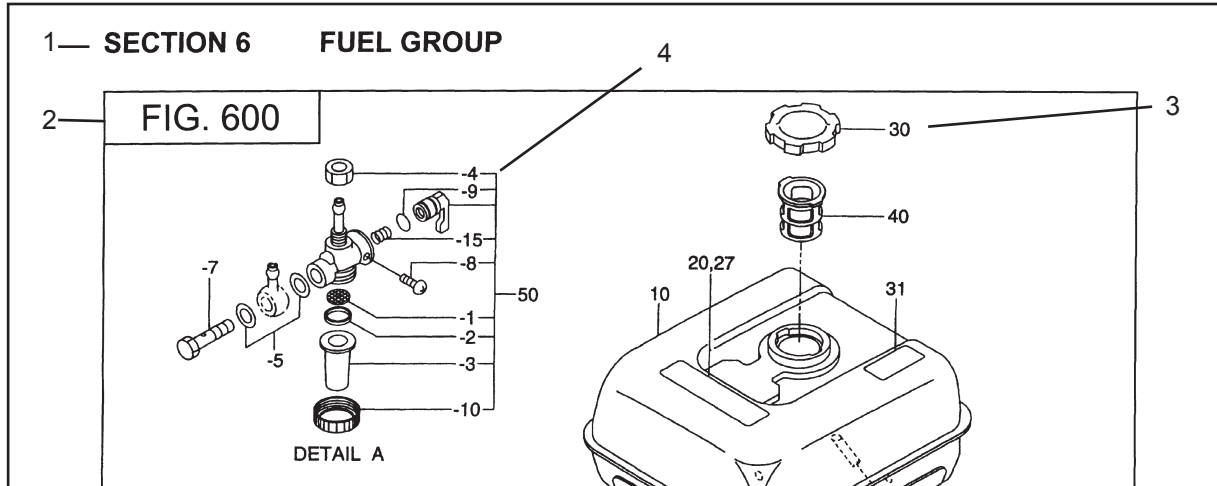

REF.	PART NO.	DESCRIPTION	QTY.	REMARKS	FROM-TO	FIG.
10	267-60103-01	FUEL TANK CP	1	YD, YS TYPE, BLACK		600
	267-60101-01	FUEL TANK CP	1	YELLOW		600
27	073-20039-00	LABEL, WARNING	1	YD, YS TYPE		600
30	043-04300-15	FUEL TANK CAP CP	1			600
31	267-95201-03	LABEL, EMISSION	1	YD, YS TYPE		600
40	064-13600-10	FUEL FILTER	1			600
50	064-20021-01	FUEL STRAINER AY	1			600
-1	064-20002-20	FILTER	1			600
-2	064-20002-30	GASKET	1			600
-3	064-20019-10	CUP	1			600

1. SECTION NAME Parts are broadly classified according to their functions. Refer to the Group Index (table of contents) for respective section name.
2. FIG. No. The FIG. number indexes the reference and part numbers to the illustration. Figure numbers that vary only in the tens place (i.e.: 700 and 710) are in a group of the same section (i.e.:Electrical Device Group).
3. REF. No . The Reference number identifies the part illustration with the corresponding part number in the part list.
4. SUBASSEMBLY SUBASSEMBLY parts of part assembly are listed below the assembly part. The subassembly part reference number is indicated by the number led by " " such as " 1", " 2".
5. PART NUMBER It is the number assigned for sales unit. Use the PART No. when making an order.
6. DESCRIPTION It is designation of the part.
7. QTY. Quantity of each part used for each product.
8. REMARKS This gives a distinctive feature and/or a supplementary comment for the type, the specification, and the part concerned. It also shows part number(s) interchangeable for the part.
9. FROM TO This section shows the CODE No. to indicate the history of progress in which improved parts have been introduced in the product. The FROM TO CODE No. helps to identify PART No. being employed in the product concerned. See the examples below:
 - 2101 The part is used in the product irrespective of CODE No.
 - The part is used in the products with CODE No. of 2101 and after this number.
 - 2100 The part is used in the products with CODE No. of 2100 and before this number.

GROUP INDEX

Group Name	Page
CRANKCASE	6
CRANKSHAFT, PISTON	8
INTAKE, EXHAUST	10
GOVERNOR, OPERATION.....	12
ELECTRIC DEVICE	14
ENGINE.....	18
GENERATOR	28
BASE, FRAME	30
CONTROL.....	32
COVER.....	36
FUEL TANK	40
ACCESSORY GROUP	42

INDEX OF DESCRIPTION SYMBOLS			
SYMBOL	DESCRIPTION	SYMBOL	DESCRIPTION
AY	ASSEMBLY	P=	PITCH (in mm)
CP.....	COMPLETE	P.T.O. (PTO)	POWER TAKE OFF
EX.....	EXPORT (from Japan)	REF.....	REFERENCE
FIG.....	FIGURE	R.H. (RH).....	RIGHT HAND SIDE
FR.....	FRONT	RR.....	REAR
"	INCH	STD.	STANDARD
INCL.	INCLUDE	SW.....	SWITCH
-L.....	LITER	T=	THICKNESS (in mm)
L=	LENGTH (in. mm)	UN	UNIT
L.H. (LH).....	LEFT HAND SIDE	U.S.....	UNDER SIZE
MECH.....	MECHANICAL	~V	VOLTAGE
NO (NON).....	NONE	~W	WATT
OPT.....	OPTIONAL	W/	WITH
O.S.	OVER SIZE	W/O	WITHOUT

SECTION 1 CRANKCASE GROUP

FIG. 100

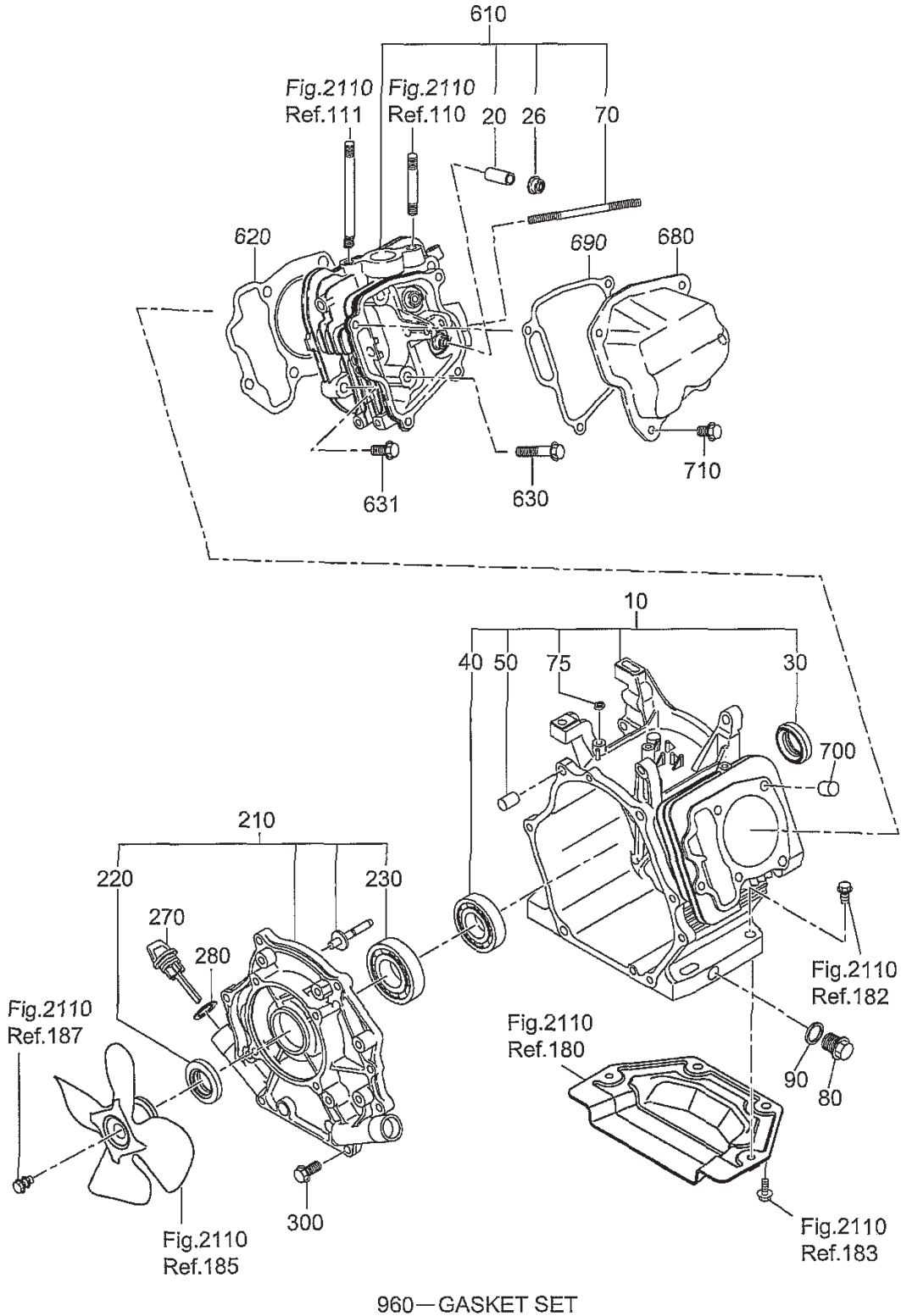

SECTION 2 CRANKSHAFT, PISTON GROUP

FIG. 200

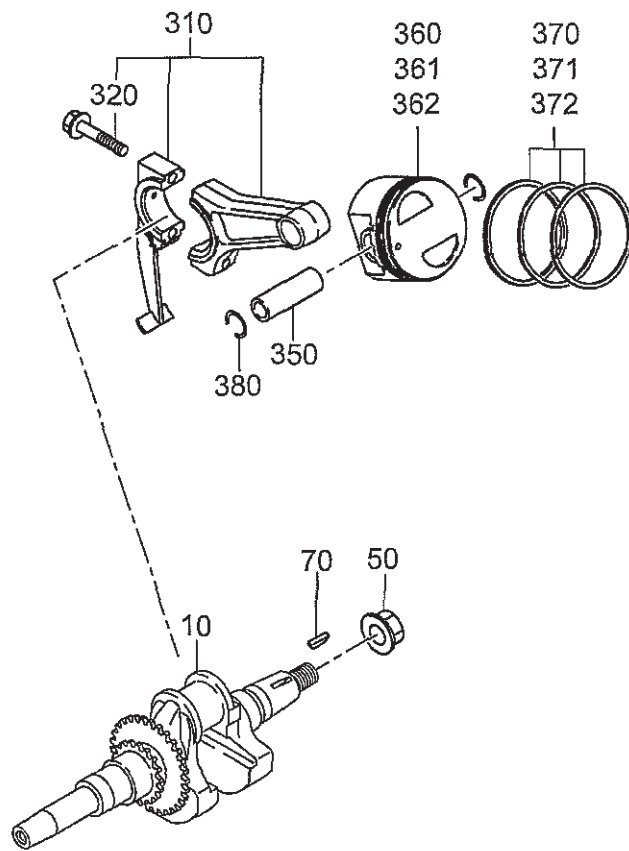

SECTION 4 GOVERNOR, OPERATION GROUP

FIG. 400

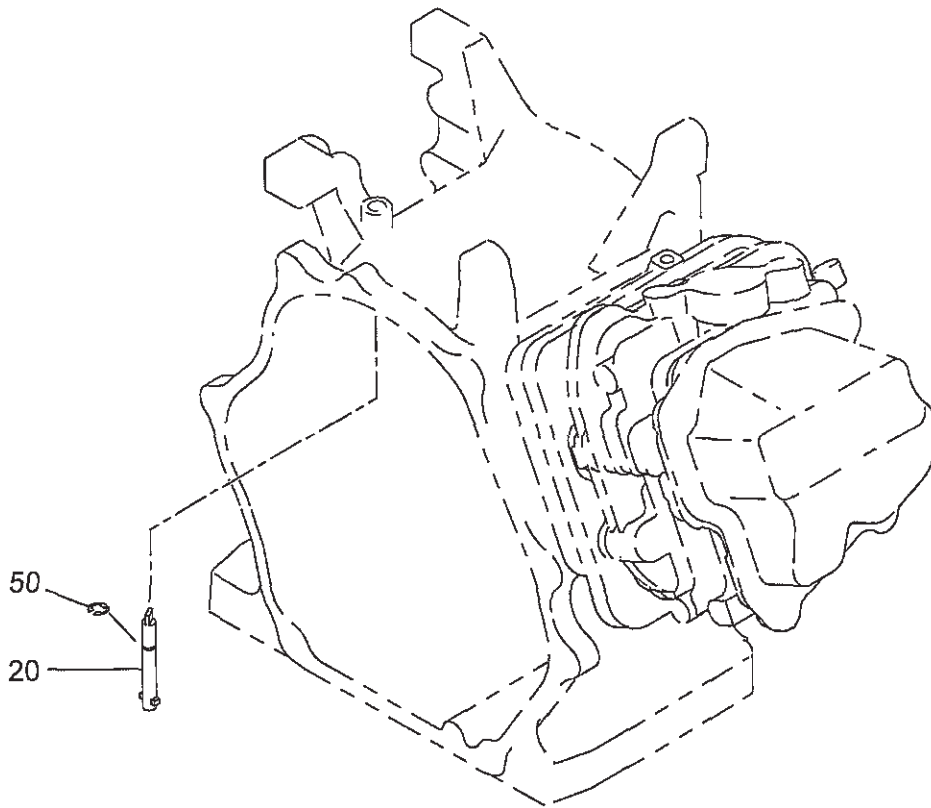

SECTION 7 ELECTRIC DEVICE GROUP

FIG. 700

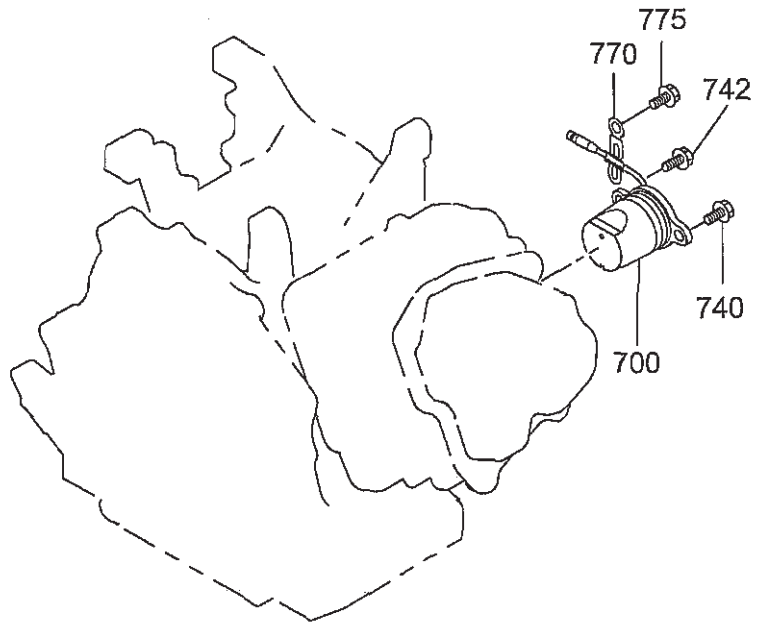
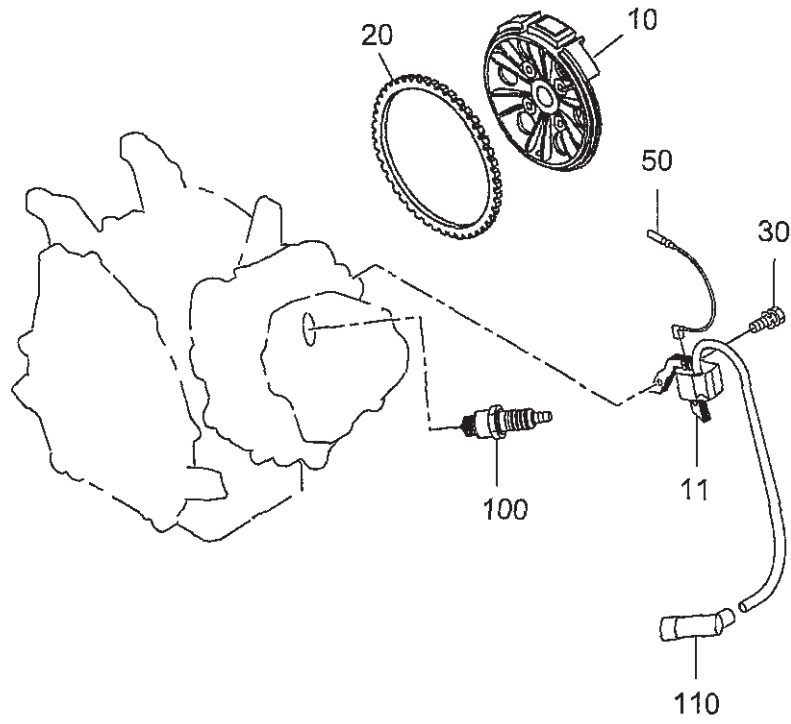

SECTION 7 ELECTRIC DEVICE GROUP

FIG. 720

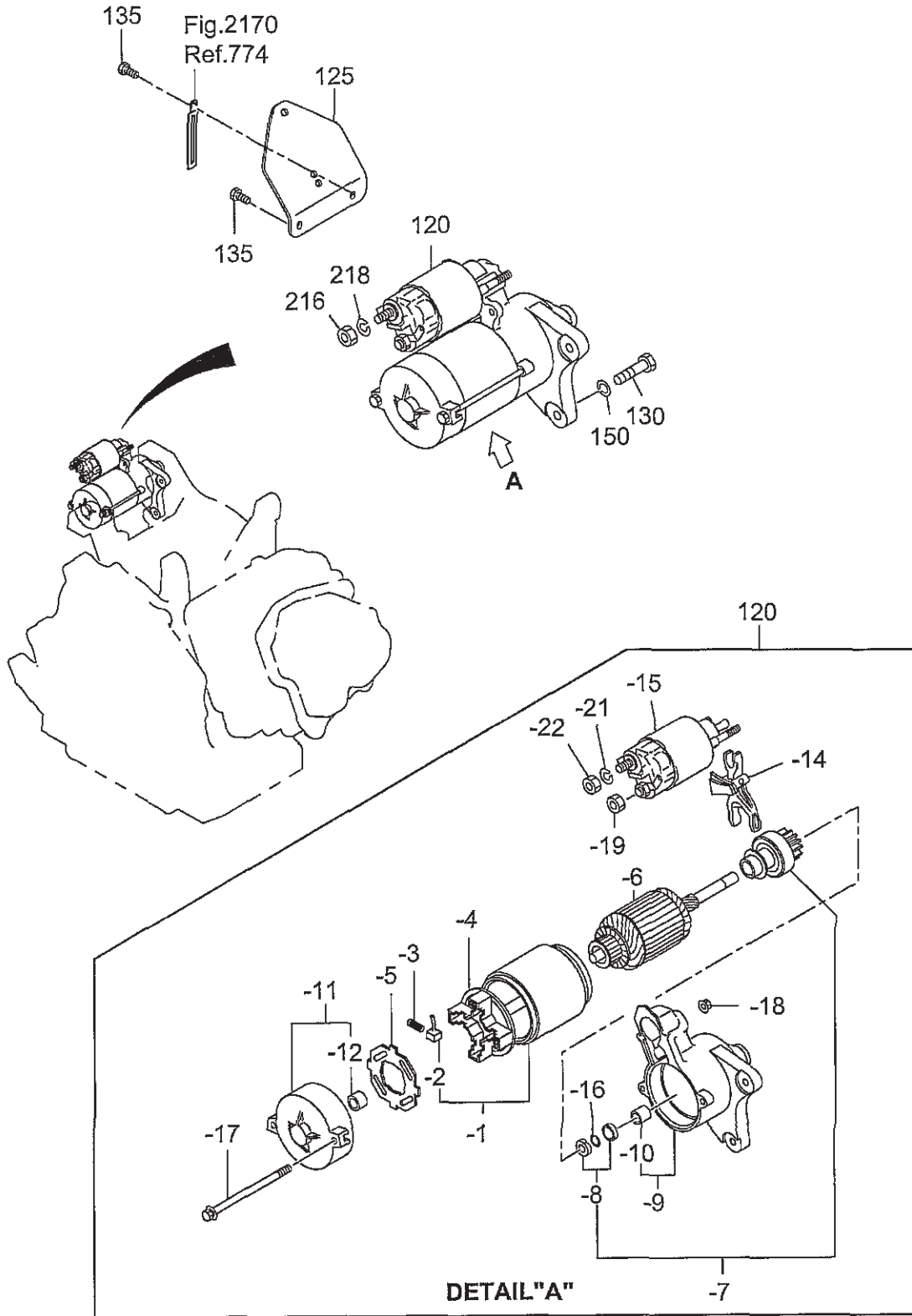

SECTION 21 ENGINE GROUP

FIG. 2110

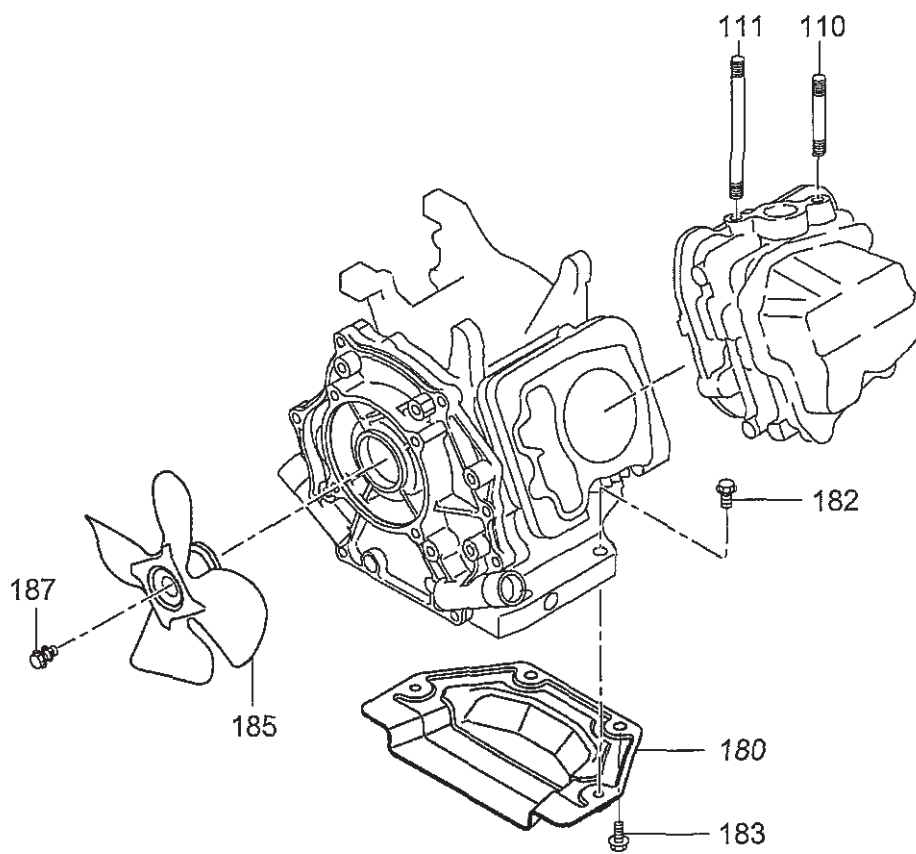

SECTION 21 ENGINE GROUP

FIG. 2130

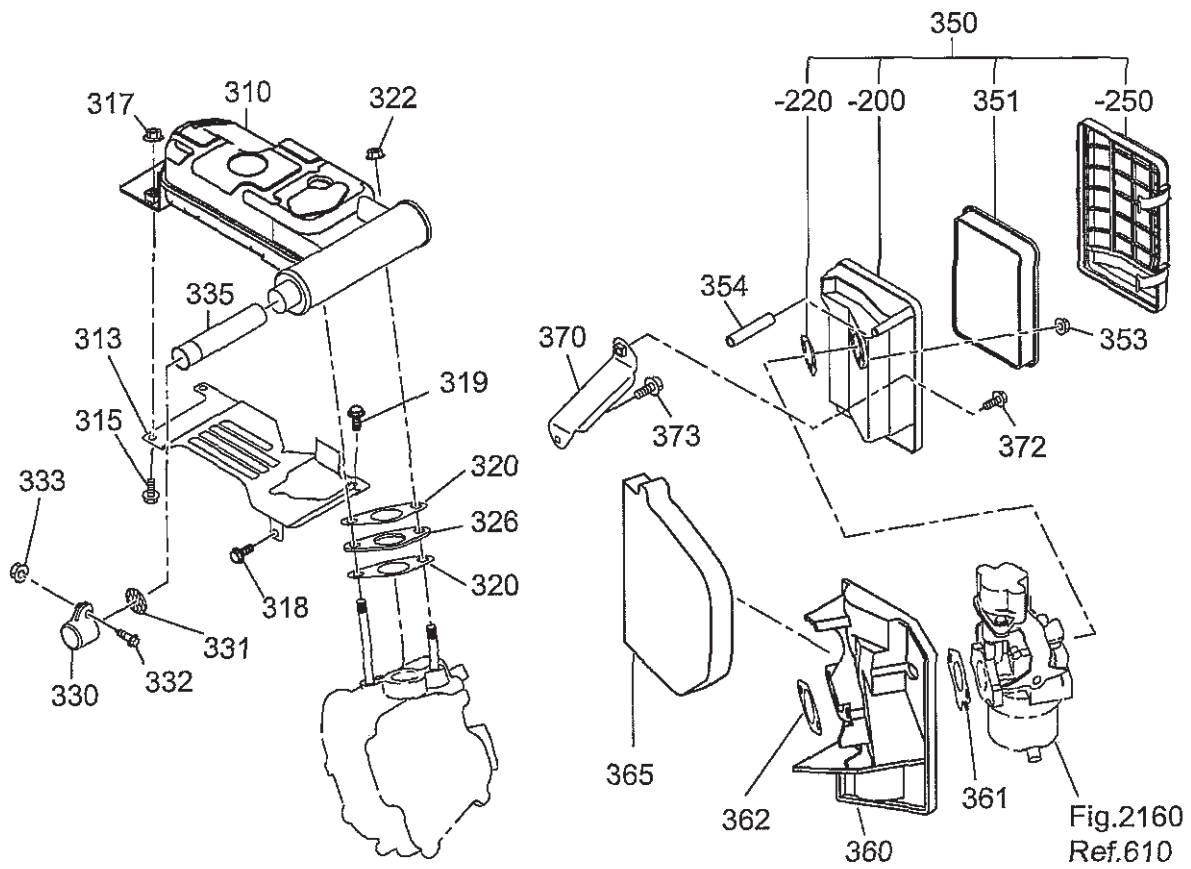

SECTION 21 ENGINE GROUP

FIG. 2150

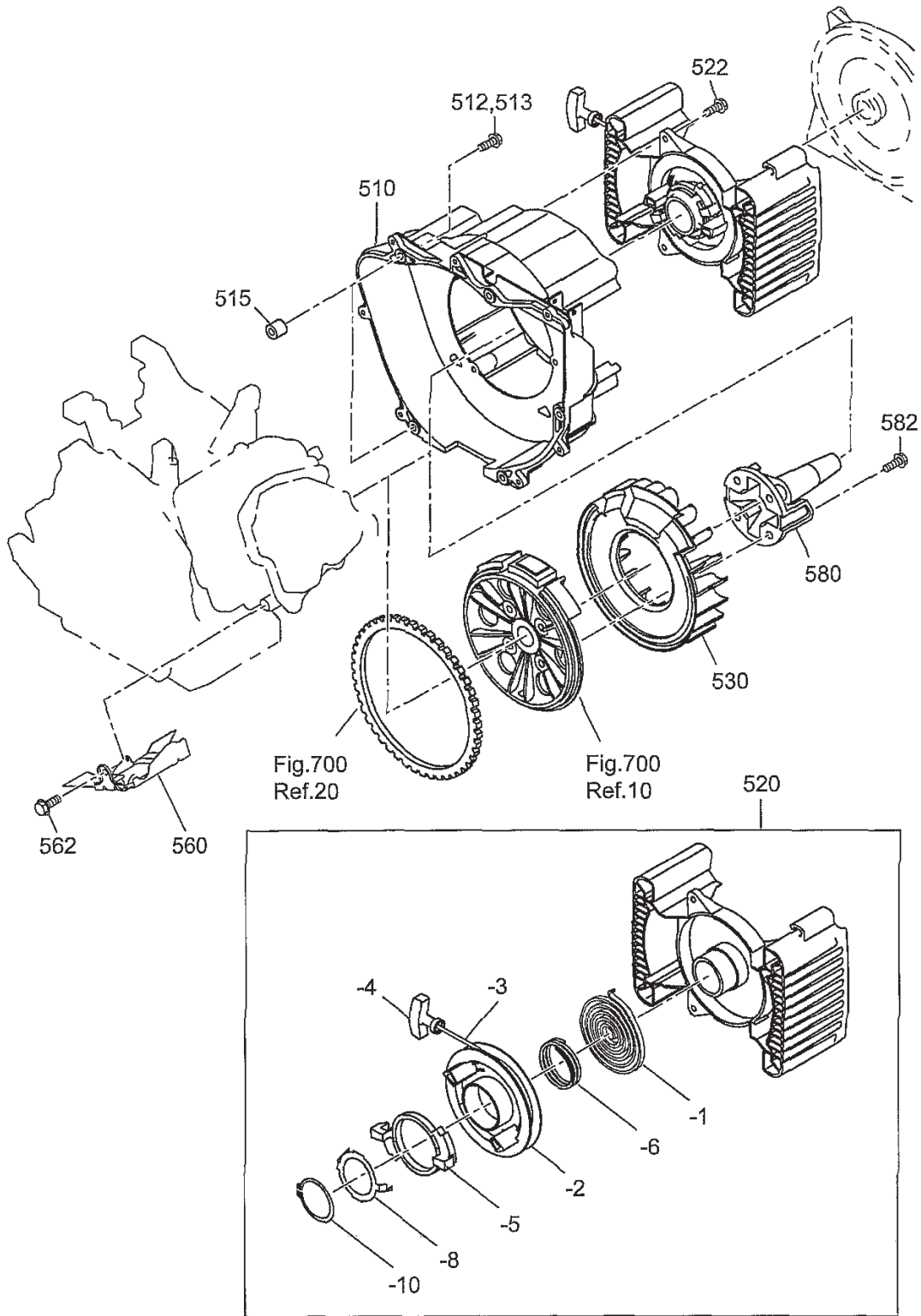

SECTION 21 ENGINE GROUP

FIG. 2160

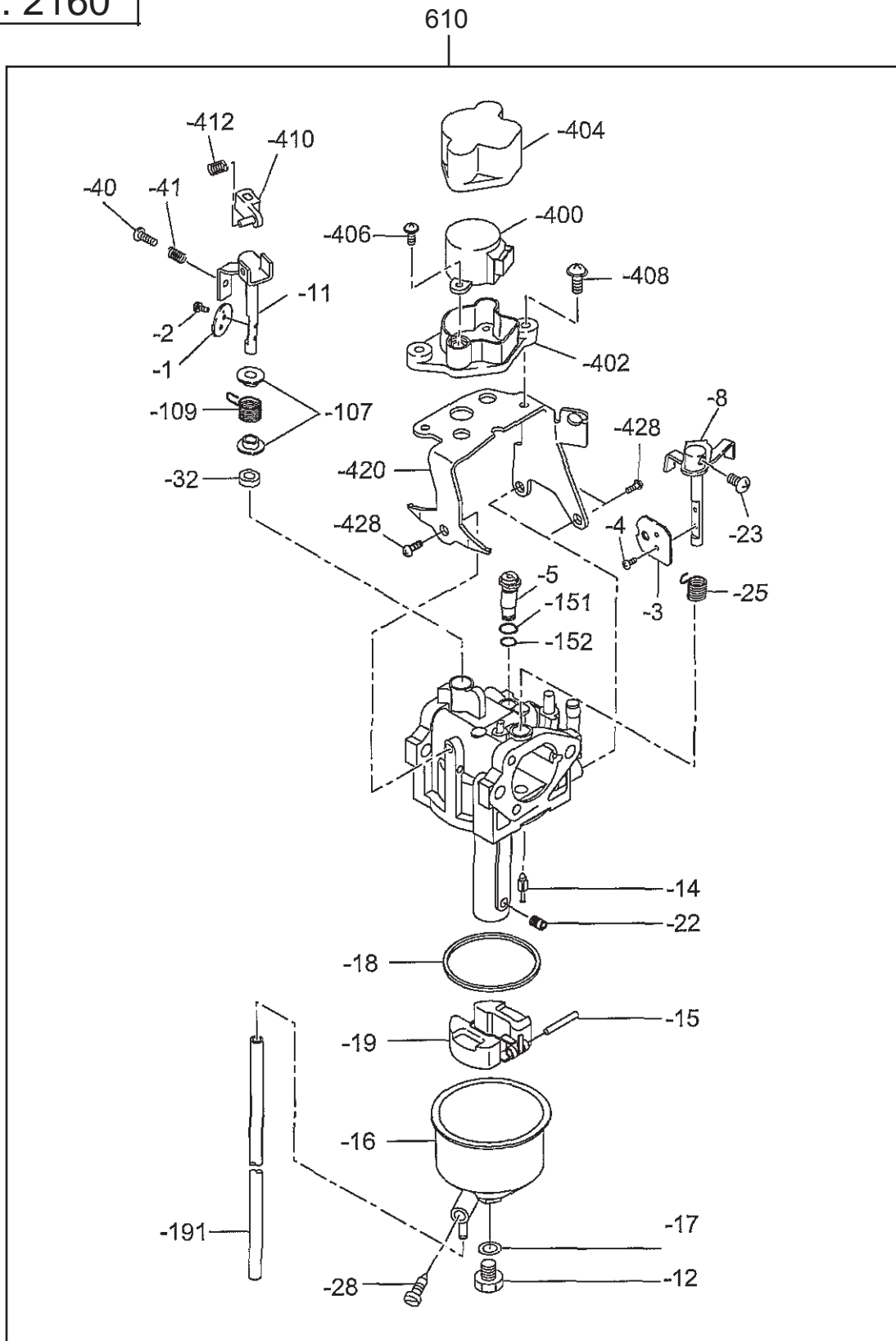

SECTION 21 ENGINE GROUP

FIG. 2170

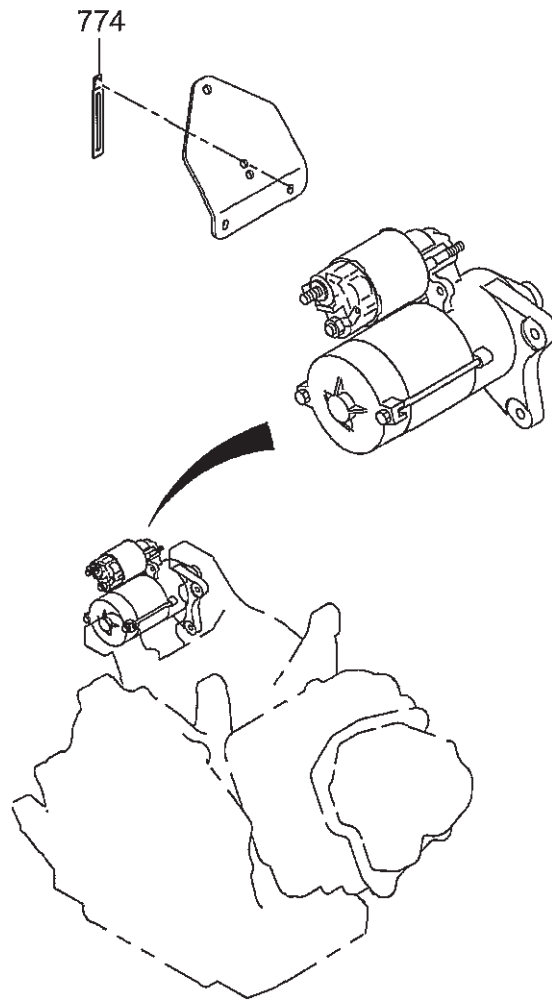

SECTION 22 GENERATOR GROUP

FIG. 2200

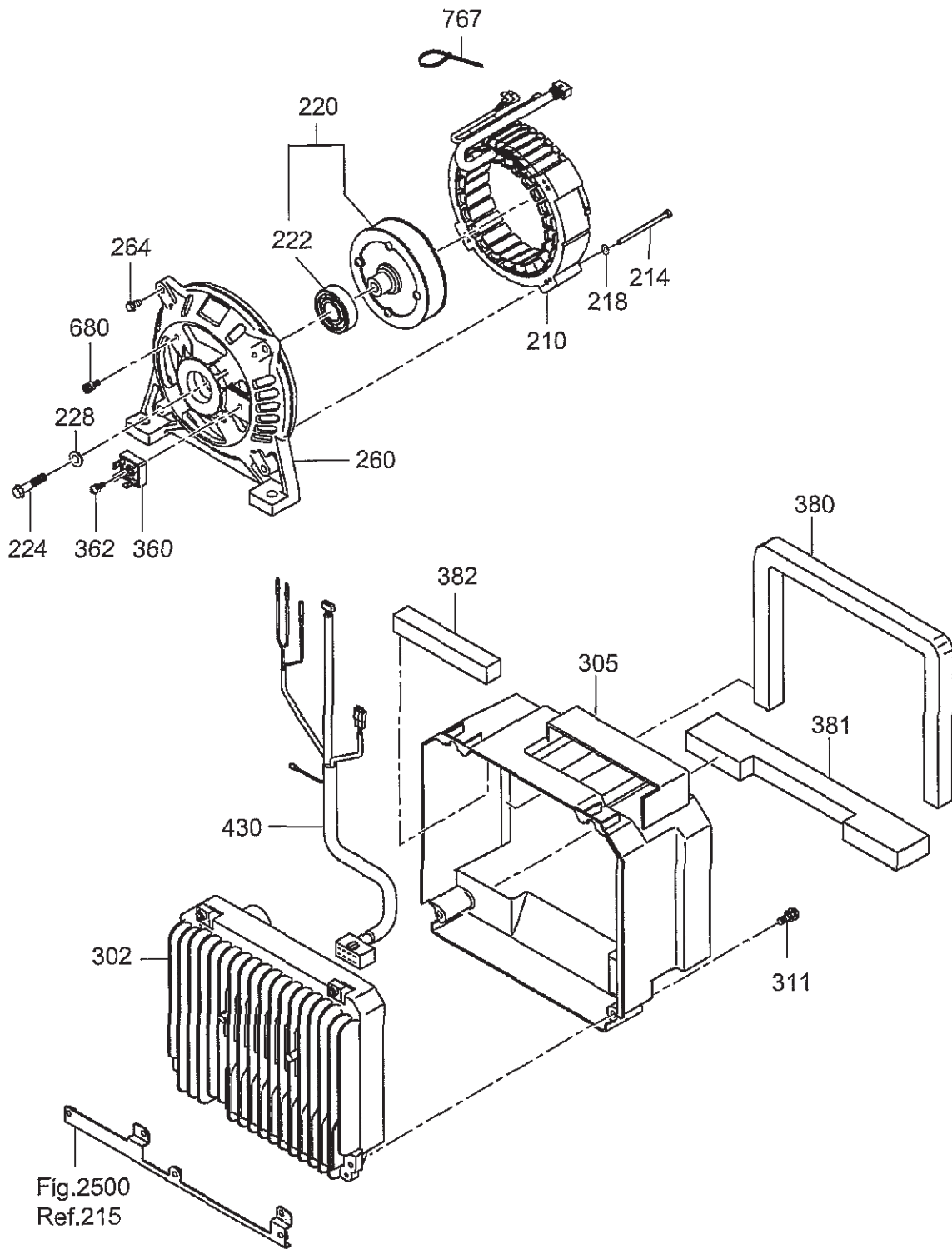

SECTION 23 BASE, FRAME GROUP

FIG. 2300

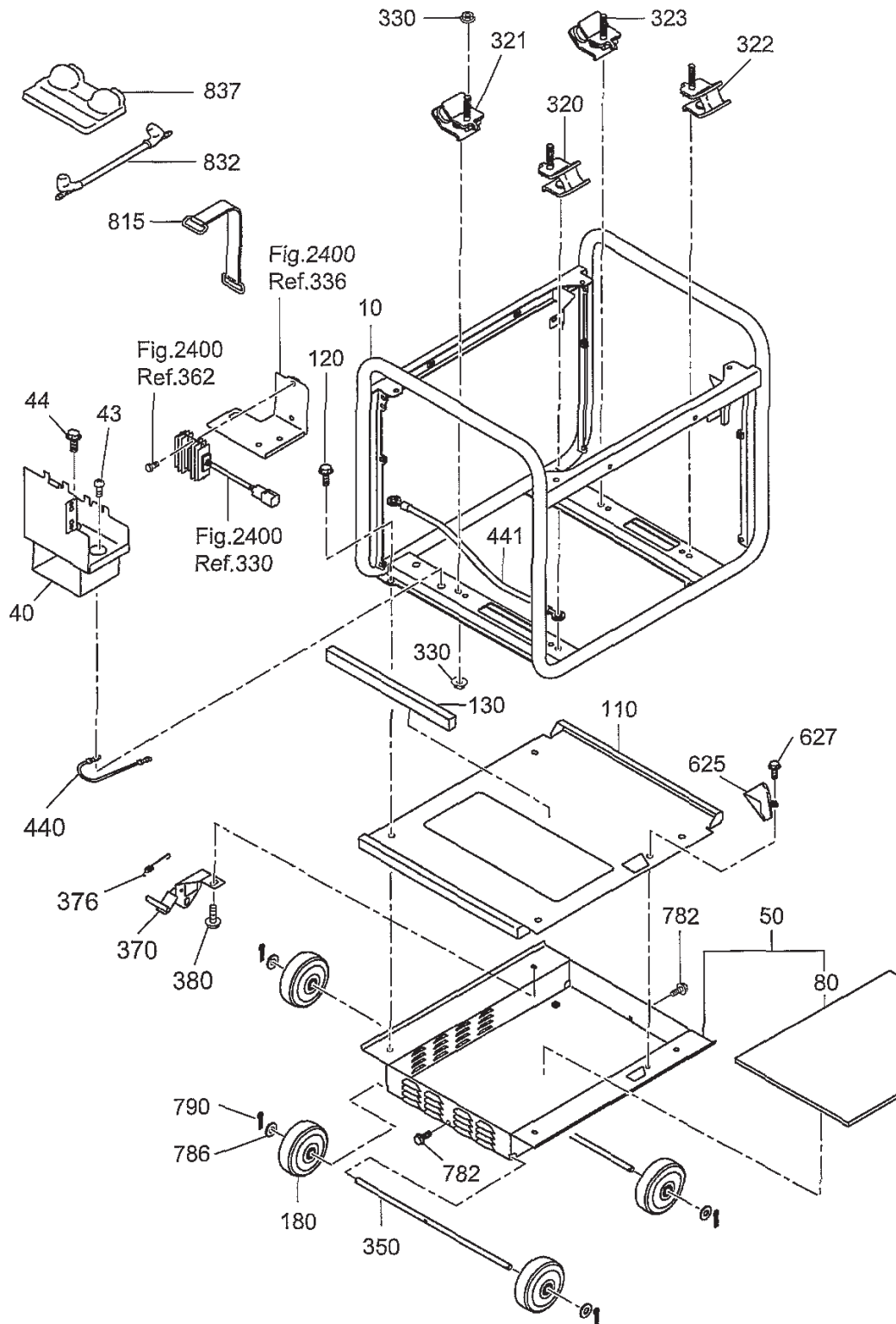

SECTION 24 CONTROL GROUP

FIG. 2400

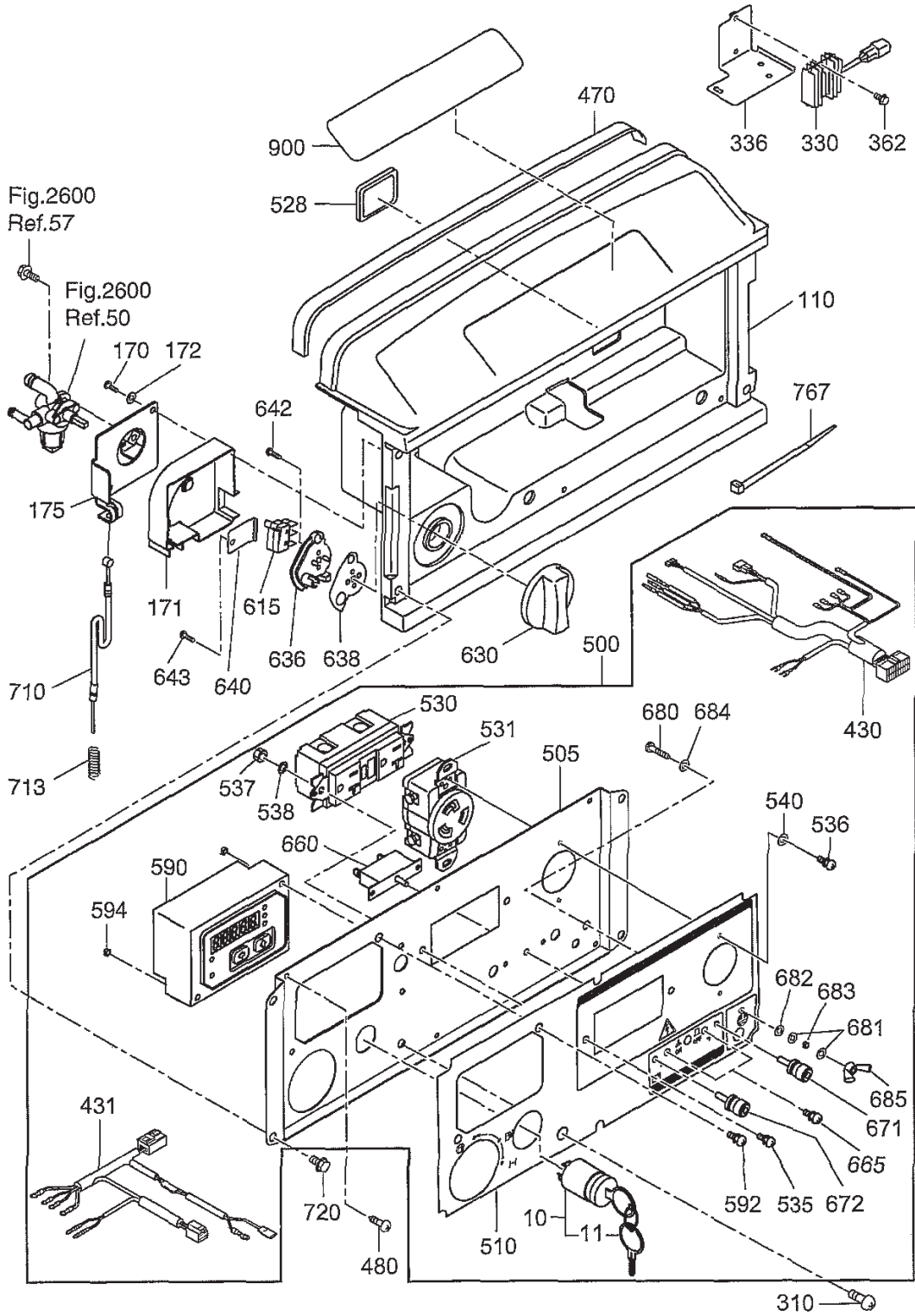

SECTION 24 CONTROL GROUP

REF	PART NO	DESCRIPTION	QTY	REMARKS	FROM - TO	FIG
10	066 00003 30	KEY SWITCH	1			2400
11	066 00099 80	KEY	2			2400
110	267 71002 03	FRONT COVER, upper	1			2400
170	015 00400 70	TAPPING SCREW	2			2400
171	33B 46001 03	COVER, cock	1			2400
172	003-10040-00	WASHER	2			2400
175	33B 46012 01	BRACKET, cock	1			2400
310	004-36061-60	SCREW and WASHER	2			2400
330	33B 47502 01	REGULATOR	1			2400
336	33B 35801 02	BRACKET, regulator	1			2400
362	011 00600 50	FLANGE BOLT	2			2400
430	34B 48001 01	WIRE HARNESS	1			2400
431	34B 48052 01	WIRE HARNESS	1			2400
470	34B 57311 03	SEAL SPONGE	1			2400
480	353 49904 08	TAPPING SCREW	6			2400
500	34D 45921 00	CONTROL PANEL	1			2400
505	33B 45013 01	PANEL PLATE	1			2400
510	34B 49119 03	SHEET	1			2400
528	227 75001 03	GROMMET	1			2400
530	388 85003 01	AC CONNECT, GFCI	1			2400
531	356 45711 08	AC CONNECT, NEMA	1			2400
535	004 35041 00	SCREW and WASHER	2			2400
536	356 59937 08	SCREW	2			2400
537	002 27040 08	NUT	2			2400
538	003 10040 00	WASHER	2			2400
540	326 00335 08	SPRING WASHER	2			2400
590	KU3 11760 11	MONITOR C/U	1			2400
592	013 10400 80	SCREW and WASHER	2			2400
594	002 17040 00	NUT	2			2400
615	33K 41811 03	MICRO SWITCH	2			2400
630	33K 42010 03	CONTROL DIAL	1			2400
636	33K 42020 03	CHOKE REEL	1			2400
638	33K 42030 13	PLATE	1			2400
640	33B 46015 01	BRACKET, micro	1			2400
642	33K-41814-08	TAPPING SCREW	2			2400
643	015 00400 70	TAPPING SCREW	1			2400
660	352 45620 08	CIRCUIT BREAKER	1			2400
665	31B 79011 03	SCREW	2			2400
671	363 45701 08	TERMINAL BOLT	1	Red		2400
672	363 45700 08	TERMINAL BOLT	1	Black		2400
680	388-88001-03	SCREW and WASHER	1			2400
681	332 00050 08	SPRING WASHER	2			2400
682	353 49903 08	WASHER	1			2400
683	353 49902 08	NUT	1			2400
684	003 30050 00	LOCK WASHER	1			2400
685	353 49901 03	WING NUT	1			2400

SECTION 24 CONTROL GROUP

FIG. 2400

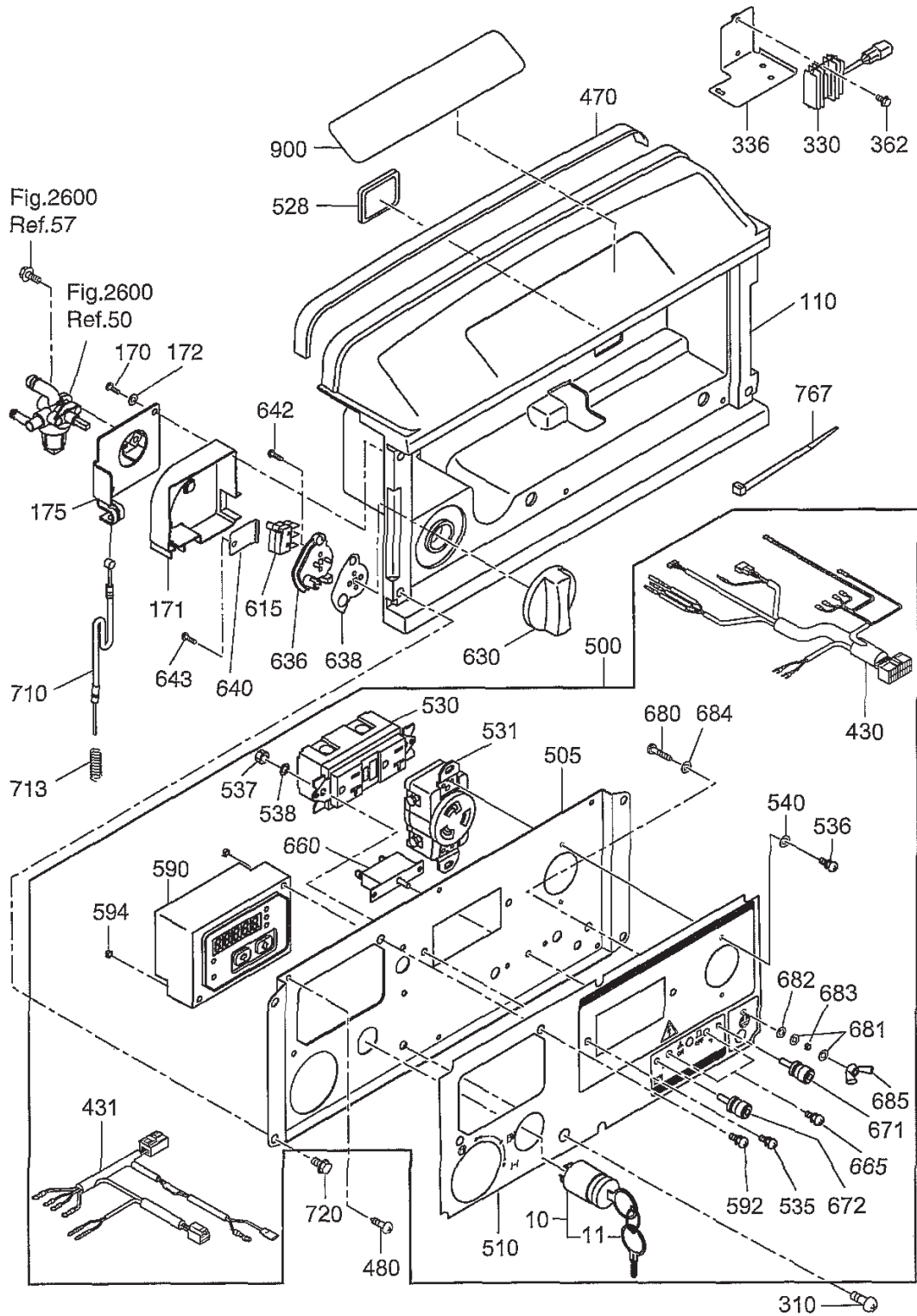

SECTION 25 COVER GROUP

FIG. 2500

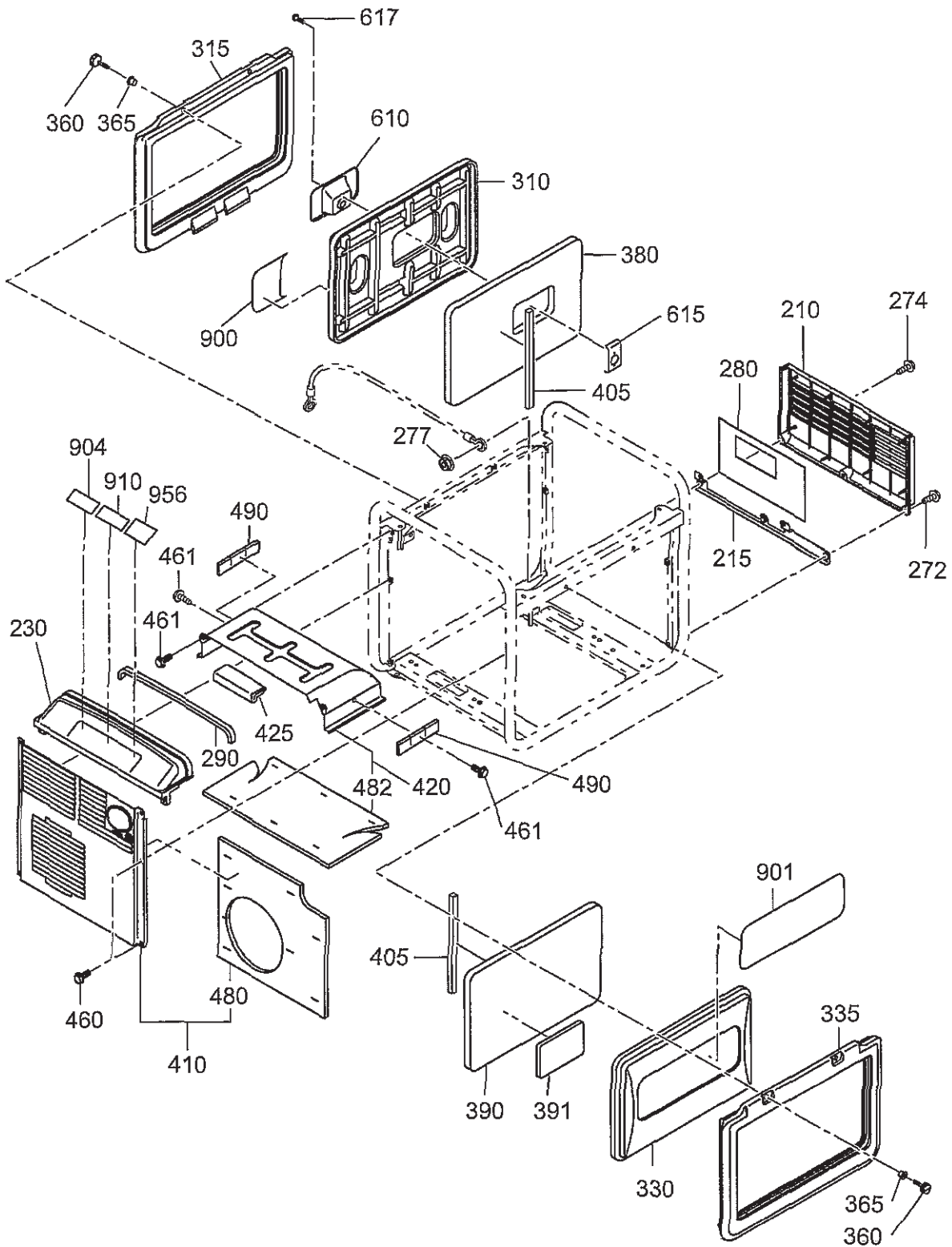

SECTION 25 COVER GROUP

FIG. 2510

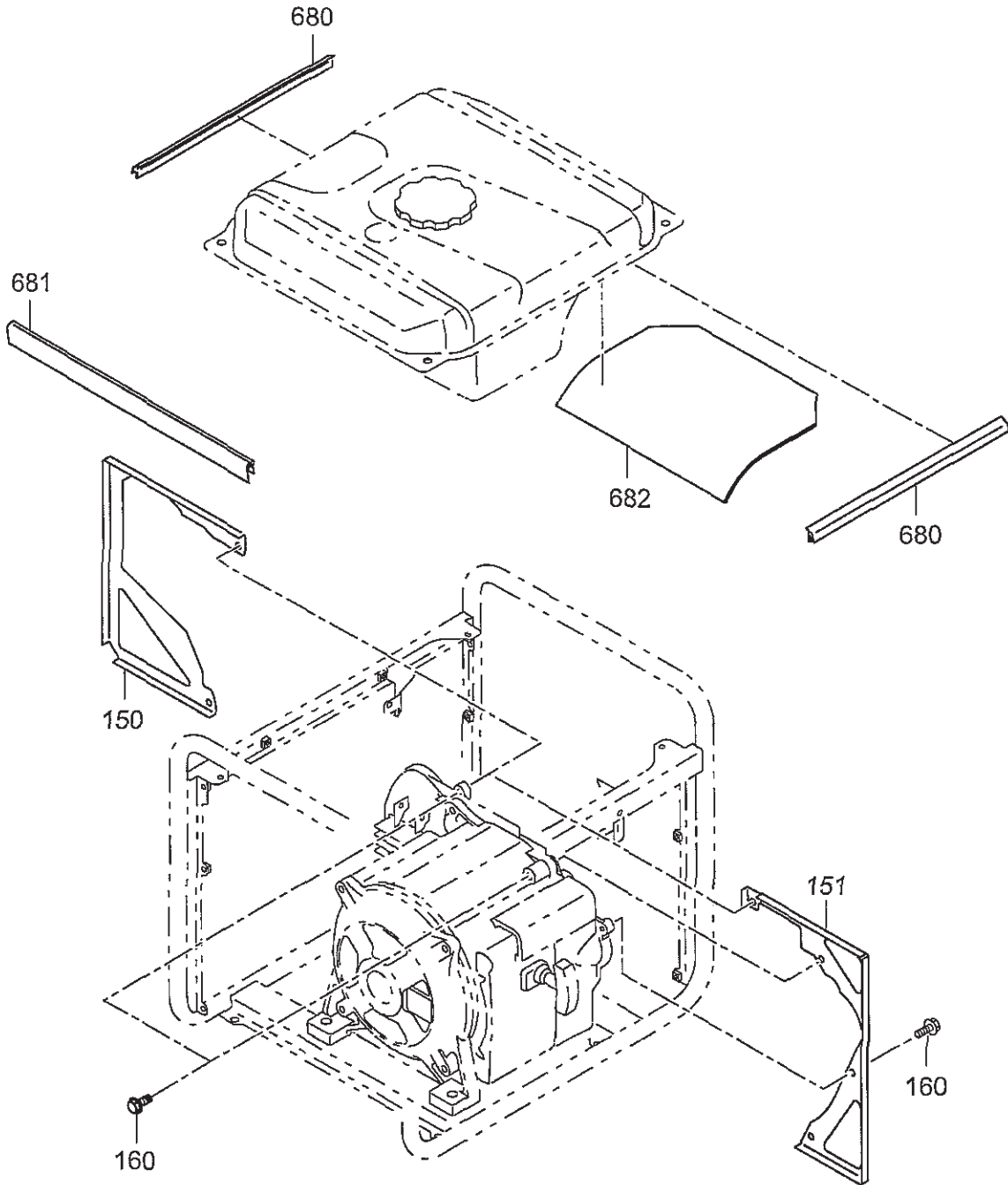

SECTION 26 FUEL TANK GROUP

FIG. 2600

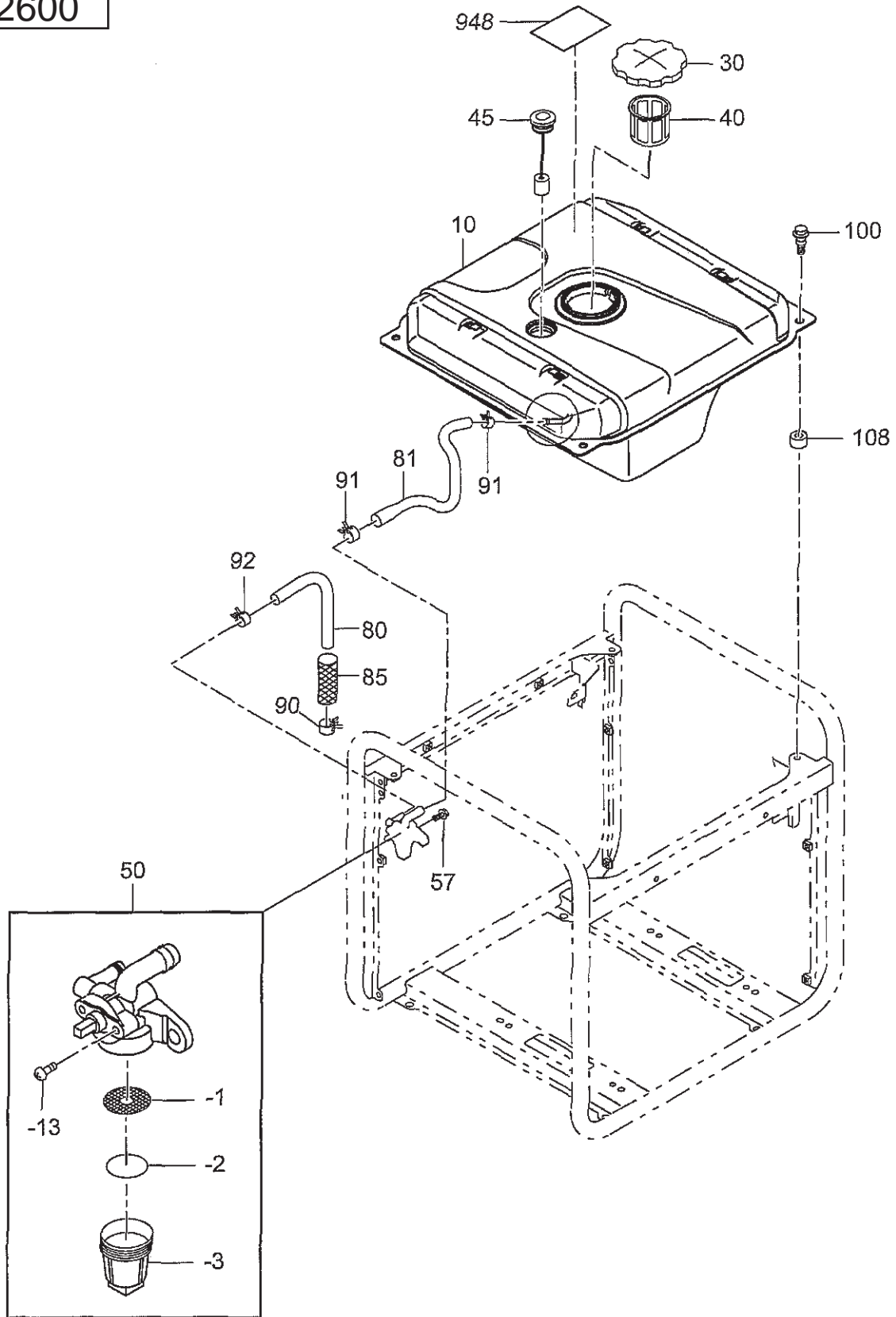

SECTION 29 ACCESSORIES GROUP

FIG. 2900

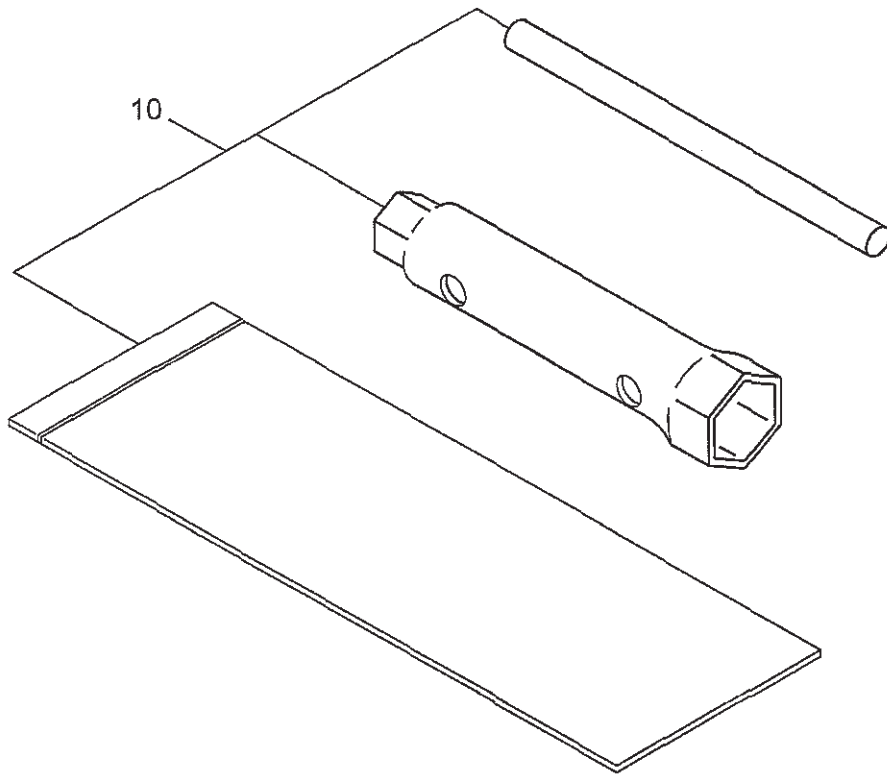

Cummins Onan



1400 73rd Avenue NE, Minneapolis, MN 55432, USA

1-800-344-0039: 24/7 CUSTOMER SERVICE WWW.ONAN.COM

Cummins®, Onan® and the "C" logo are registered trademarks of Cummins Inc.

©2006 Cummins Power Generation.