



Operator's Manual

Detector™/Sentinel™ Controls GENERATOR SETS

Models

- GGHB
- GGHC
- GGHD

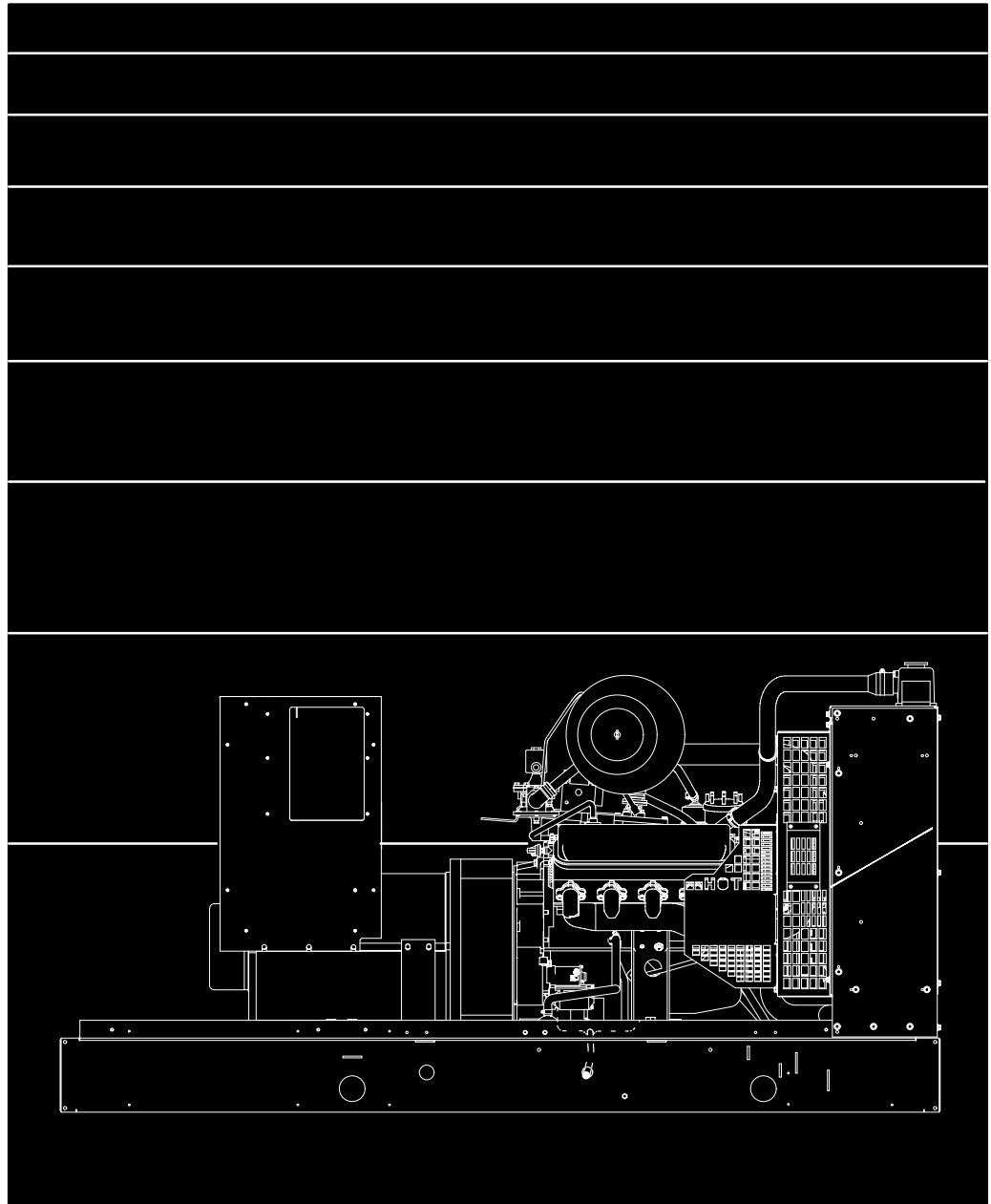

Safety Precautions

Before operating the generator set (genset), read the Operator's Manual and become familiar with it and the equipment. **Safe and efficient operation can be achieved only if the equipment is properly operated and maintained.** Many accidents are caused by failure to follow fundamental rules and precautions.

The following symbols, found throughout this manual, alert you to potentially dangerous conditions to the operator, service personnel, or the equipment.

⚠ DANGER *This symbol warns of immediate hazards which will result in severe personal injury or death.*

⚠ WARNING *This symbol refers to a hazard or unsafe practice which can result in severe personal injury or death.*

⚠ CAUTION *This symbol refers to a hazard or unsafe practice which can result in personal injury or product or property damage.*

FUEL AND FUMES ARE FLAMMABLE

Fire, explosion, and personal injury or death can result from improper practices.

- DO NOT fill fuel tanks while engine is running, unless tanks are outside the engine compartment. Fuel contact with hot engine or exhaust is a potential fire hazard.
- DO NOT permit any flame, cigarette, pilot light, spark, arcing equipment, or other ignition source near the generator set or fuel tank.
- Fuel lines must be adequately secured and free of leaks. Fuel connection at the engine should be made with an approved flexible line. Do not use copper piping on flexible lines as copper will become brittle if continuously vibrated or repeatedly bent.
- Natural gas is lighter than air, and will tend to gather under hoods. Propane is heavier than air, and will tend to gather in sumps or low areas. NFPA code requires all persons handling propane to be trained and qualified.

- Be sure all fuel supplies have a positive shutoff valve.
- Be sure battery area has been well-ventilated prior to servicing near it. Lead-acid batteries emit a highly explosive hydrogen gas that can be ignited by arcing, sparking, smoking, etc.

EXHAUST GASES ARE DEADLY

- Provide an adequate exhaust system to properly expel discharged gases away from enclosed or sheltered areas and areas where individuals are likely to congregate. Visually and audibly inspect the exhaust daily for leaks per the maintenance schedule. Make sure that exhaust manifolds are secured and not warped. Do not use exhaust gases to heat a compartment.
- Be sure the unit is well ventilated.
- Engine exhaust and some of its constituents are known to the state of California to cause cancer, birth defects, and other reproductive harm.

MOVING PARTS CAN CAUSE SEVERE PERSONAL INJURY OR DEATH

- Keep your hands, clothing, and jewelry away from moving parts.
- Before starting work on the generator set, disconnect battery charger from its AC source, then disconnect starting batteries, negative (-) cable first. This will prevent accidental starting.
- Make sure that fasteners on the generator set are secure. Tighten supports and clamps, keep guards in position over fans, drive belts, etc.
- Do not wear loose clothing or jewelry in the vicinity of moving parts, or while working on electrical equipment. Loose clothing and jewelry can become caught in moving parts. Jewelry can short out electrical contacts and cause shock or burning.
- If adjustment must be made while the unit is running, use extreme caution around hot manifolds, moving parts, etc.

ELECTRICAL SHOCK CAN CAUSE SEVERE PERSONAL INJURY OR DEATH

- Remove electric power before removing protective shields or touching electrical equipment. Use rubber insulative mats placed on dry wood platforms over floors that are metal or concrete when around electrical equipment. Do not wear damp clothing (particularly wet shoes) or allow skin surface to be damp when handling electrical equipment.
- Use extreme caution when working on electrical components. High voltages can cause injury or death. DO NOT tamper with interlocks.
- Follow all applicable state and local electrical codes. Have all electrical installations performed by a qualified licensed electrician. Tag and lock open switches to avoid accidental closure.
- DO NOT CONNECT GENERATOR SET DIRECTLY TO ANY BUILDING ELECTRICAL SYSTEM. Hazardous voltages can flow from the generator set into the utility line. This creates a potential for electrocution or property damage. Connect only through an approved isolation switch or an approved paralleling device.

GENERAL SAFETY PRECAUTIONS

- Coolants under pressure have a higher boiling point than water. DO NOT open a radiator or heat exchanger pressure cap while the engine is running. Allow the generator set to cool and bleed the system pressure first.
- Benzene and lead, found in some gasoline, have been identified by some state and federal agencies

as causing cancer or reproductive toxicity. When checking, draining or adding gasoline, take care not to ingest, breathe the fumes, or contact gasoline.

- Used engine oils have been identified by some state or federal agencies as causing cancer or reproductive toxicity. When checking or changing engine oil, take care not to ingest, breathe the fumes, or contact used oil.
- Provide appropriate fire extinguishers and install them in convenient locations. Consult the local fire department for the correct type of extinguisher to use. Do not use foam on electrical fires. Use extinguishers rated ABC by NFPA.
- Make sure that rags are not left on or near the engine.
- Remove all unnecessary grease and oil from the unit. Accumulated grease and oil can cause overheating and engine damage which present a potential fire hazard.
- Keep the generator set and the surrounding area clean and free from obstructions. Remove any debris from the set and keep the floor clean and dry.
- Do not work on this equipment when mentally or physically fatigued, or after consuming any alcohol or drug that makes the operation of equipment unsafe.
- Substances in exhaust gases have been identified by some state or federal agencies as causing cancer or reproductive toxicity. Take care not to breathe or ingest or come into contact with exhaust gases.

KEEP THIS MANUAL NEAR THE GENSET FOR EASY REFERENCE



Table of Contents

SECTION	TITLE	PAGE
	SAFETY PRECAUTIONS	iii
1	INTRODUCTION	
	General	1-1
	How to Obtain Service	1-2
2	SPECIFICATIONS	2-1
3	OPERATION (DETECTOR CONTROL)	
	General	3-1
	Prestart Checks	3-1
	Control Panel	3-1
	Generator AC Voltage Regulator	3-5
	Engine Control Module	3-5
	Starting	3-6
	Stopping	3-6
4	TROUBLESHOOTING (DETECTOR CONTROL)	
	Safety Considerations	4-1
	Troubleshooting Charts	4-2
5	OPERATION (SENTINEL CONTROL)	
	General	5-1
	Prestart Checks	5-1
	Control Panel	5-1
	Generator AC Voltage Regulator	5-3
	Engine Monitoring	5-3
	Starting	5-3
	Stopping	5-4
6	TROUBLESHOOTING (SENTINEL CONTROL)	
	Safety Considerations	6-1
	Troubleshooting Charts	6-2

⚠ WARNING: ⚠

The engine exhaust from this product contains chemicals known to the State of California to cause cancer, birth defects or other reproductive harm.



SECTION	TITLE	PAGE
7	MAINTENANCE	
	General	7-1
	Maintenance Schedule	7-2
	Generator Set Inspection	7-3
	Lubrication System	7-5
	Cooling System	7-7
	Air Filter	7-9
	Drive Belt	7-10
	Ignition System	7-11
	Battery	7-12
	Out-of-Service Protection	7-12
8	ADJUSTMENTS	
	Output Voltage Adjustment	8-1
	Fuel System Adjustments	8-1
9	OPERATING RECOMMENDATIONS	
	Break-In	9-1
	No-Load Operation	9-1
	Exercise Period	9-1
	Low Operating Temperatures	9-1
	Power Rating Factors	9-1



1. Introduction

GENERAL

Each operator should read this manual before operating the set for the first time. A generator set (genset) must be operated and maintained properly if you are to expect safe, reliable and quiet operation. The manual includes a troubleshooting guide and a maintenance schedule.

The engine manual is included with the set. Where there is conflicting information, this manual takes precedence over the engine manual.

There are two types of control panels available for the generator set, the Detector control or the Sentinel control (Figure 1-1). The panels shown include optional features (indicators, meters and switches) that may or may not be included with the genset. All standard and optional controls and indicators are discussed in Sections 3 and 5 of this manual.

There are separate *Operation* and *Troubleshooting* sections for gensets using the Sentinel control or the Detector control (Figure 1-1). Refer to the *Table of Contents* for specific information relating to your genset. The remaining sections apply to all versions.

⚠ WARNING *Improper operation and maintenance can lead to severe personal injury or loss of life and property by fire, electrocution, mechanical breakdown or exhaust gas asphyxiation. Read and follow the safety precautions on page iii and carefully observe all instructions and precautions in this manual.*

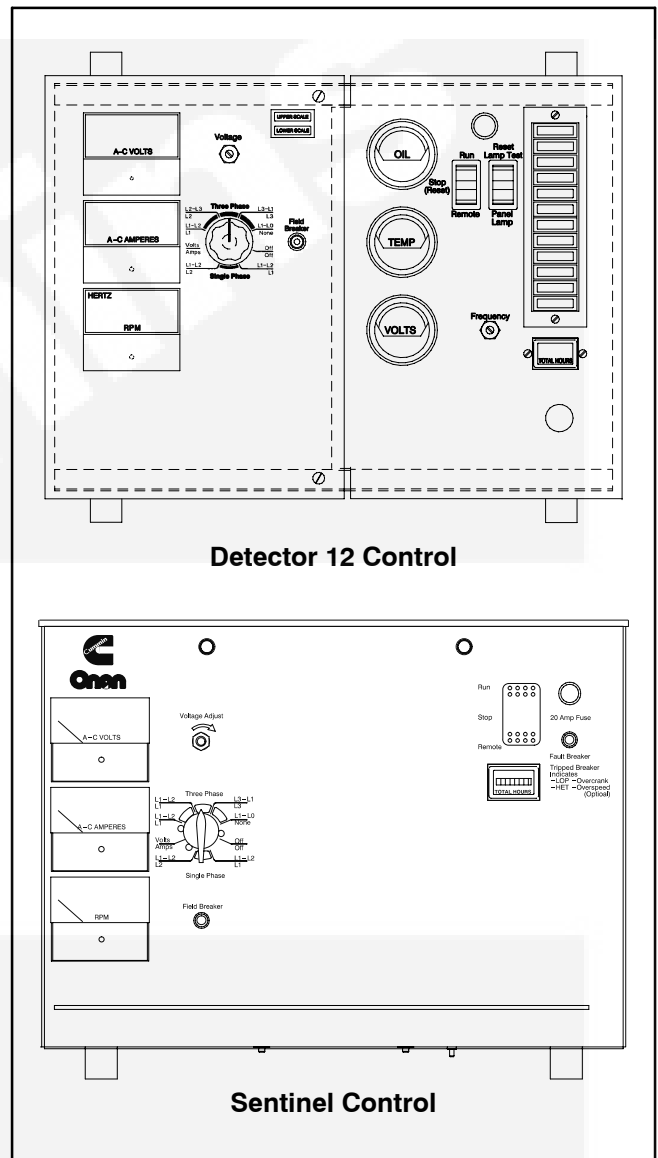

FIGURE 1-1. CONTROL PANEL CONFIGURATIONS

HOW TO OBTAIN SERVICE

When the generator set requires servicing, contact your nearest Cummins®/Onan® dealer or distributor. Factory-trained Parts and Service representatives are ready to handle all your service needs.

If you are unable to locate a dealer or distributor, consult the Yellow Pages. Typically, our distributors are listed under:

GENERATORS-ELECTRIC or
ELECTRICAL PRODUCTS

For the name of your local Cummins/Onan or Onan-only distributor in the United States or Canada, call

1-800-888-ONAN (this automated service utilizes touch-tone phones only). By entering your area code and the first three digits of your local telephone number, you will receive the name and telephone number of the distributor nearest you.

For outside North America, call Onan Corporation, 1-612-574-5000, 7:30 AM to 4:00 PM, Central Standard Time, Monday through Friday. Or, send a fax to Onan using the fax number 1-612-574-8087.

When contacting your distributor, always supply the complete Model, Specification, and Serial Number as shown on the generator set nameplate.

⚠ WARNING

INCORRECT SERVICE OR PARTS REPLACEMENT CAN RESULT IN SEVERE PERSONAL INJURY, DEATH, AND/OR EQUIPMENT DAMAGE. SERVICE PERSONNEL MUST BE QUALIFIED TO PERFORM ELECTRICAL AND/OR MECHANICAL SERVICE.

Onan is a registered trademark of Onan Corporation.

Cummins is a registered trademark of Cummins Engine Company, Inc.



2. Specifications

MODEL	GGHB	GGHC	GGHD
Engine Onan Modified Ford V-8	LSG-875	LSG-875	LSG-875
Generator kW Rating (See Genset Nameplate)			
Fuel or a combination of two fuels	Propane Natural Gas	Propane Natural Gas	Propane Natural Gas
Exhaust Connection Backpressure (Max. Allowed)	3 inch NPT 20.4 inch H ₂ O	3 inch NPT 20.4 inch H ₂ O	3 inch NPT 20.4 inch H ₂ O
Electrical System Starting Voltage Battery Charging Alternator (Max. Rating)	12 Volts DC 37 A	12 Volts DC 37 A	12 Volts DC 37 A
Cooling System Capacity with Standard Radiator	7.2 Gal (27.3 L)	7.7 Gal (29 L)	7.7 Gal (29 L)
Lubricating System Oil Capacity with Filters	9 Qts (8.6 L)	10 Qts (9.5 L)	10 Qts (9.5 L)
Tune-up Specifications Spark Plug Gap	0.035 (0.89 mm)	0.035 (0.89 mm)	0.035 (0.89 mm)
Battery Required Battery Voltage Group Number	12 Volts DC 31	12 Volts DC 31	12 Volts DC 31

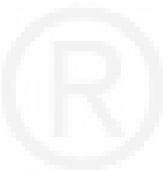

3. Operation (Detector Control)

GENERAL

This section covers prestart checks, starting and stopping and operating the generator set. Each operator should read through this entire section before attempting to start the set. It is essential that the operator be completely familiar with the set for safe operation. Refer to *Section 9* for operating recommendations.

PRESTART CHECKS

Before starting, be sure the following checks have been made and the unit is ready for operation. Refer to the *Maintenance* section for the recommended procedures.

Lubrication

Check the engine oil level. Keep the oil level as close as possible to the dipstick high mark without overfilling.

Coolant

Check the engine coolant level. The cold coolant level should be about 3/4 inch (18 mm) below the radiator cap lower sealing surface. Do not check while the engine is hot.

diator cap lower sealing surface. Do not check while the engine is hot.

⚠️WARNING *Contact with hot coolant can result in severe burns. Do not bleed hot, pressurized coolant from a closed cooling system.*

Fuel

Open all manual shutoff valves in the fuel supply system.

Exhaust

Check to make sure entire exhaust system is tight, that no combustible materials are near system, and gases are discharged away from building openings.

CONTROL PANEL

The following describes the function and operation of the Detector Control panel. All instruments and control switches are located on the face of the control panel as illustrated in Figures 3-1 through 3-3. The control panel is separated into a DC panel for monitoring the engine and an AC panel for monitoring the generator.

EXHAUST GAS IS DEADLY!

Exhaust gases contain carbon monoxide, an odorless and colorless gas. Carbon monoxide is poisonous and can cause unconsciousness and death. Symptoms of carbon monoxide poisoning can include:

- ***Dizziness***
- ***Nausea***
- ***Headache***
- ***Weakness and Sleepiness***
- ***Throbbing in Temples***
- ***Muscular Twitching***
- ***Vomiting***
- ***Inability to Think Coherently***

IF YOU OR ANYONE ELSE EXPERIENCE ANY OF THESE SYMPTOMS, GET OUT INTO THE FRESH AIR IMMEDIATELY. If symptoms persist, seek medical attention. Shut down the unit and do not operate until it has been inspected and repaired.

Protection against carbon monoxide inhalation includes proper installation and regular, frequent visual and audible inspections of the complete exhaust system.

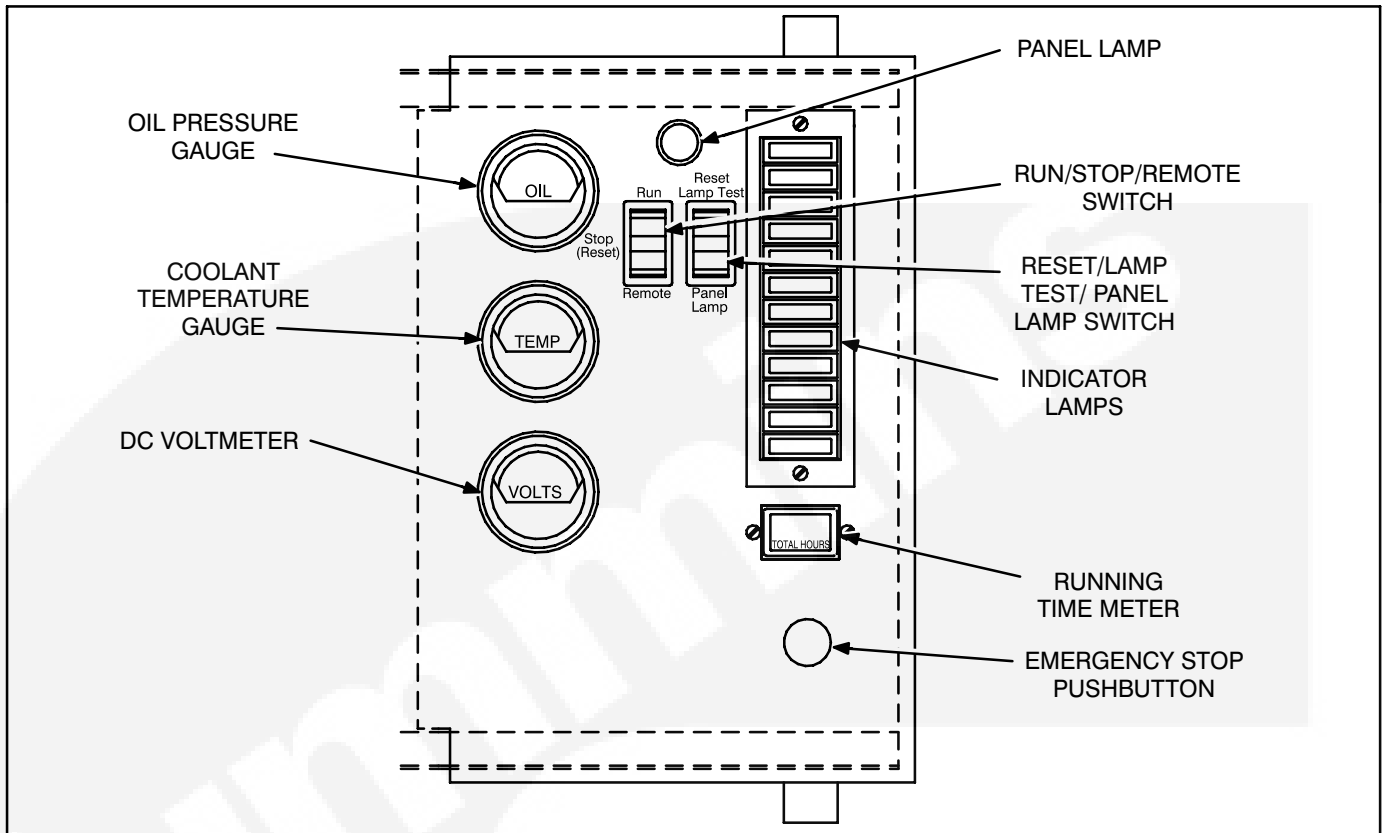

FIGURE 3-1. DC CONTROL PANEL (DETECTOR 12 SHOWN)

DC Panel

Panel Lamp: Illuminates control panel.

Oil Pressure Gauge: Indicates pressure of lubricating oil in engine (wired to a sensor located on the engine). Normal oil pressure is 40 to 65 psi (276 to 449 kPa) at normal operating temperature.

Coolant Temperature Gauge: Indicates temperature of circulating coolant in engine (wired to a sensor located on engine). Engine coolant temperature is typically between 165° to 195° F (74° to 91° C).

DC Voltmeter: Indicates the battery charging system voltage. Normal charging voltage is 12 to 14 volts.

Run/Stop/Remote Switch: Starts and stops the set locally, or from a remote location wired to the control engine monitor board.

Running Time Meter: Registers the total number of hours the unit has run. Use it to keep a record of periodic servicing. Time is cumulative; meter cannot be reset.

Reset/Lamp Test/Panel Lamp Switch: Resets the fault circuit only when the Run/Stop/Remote switch is in the Stop (Reset) position. Tests fault lamps and turns on the control panel lamp.

Emergency Stop Button (Optional): Push-in switch for emergency shutdown of the engine. To reset, pull switch out and move Run/Stop/Remote switch to Stop position. Then push test switch to Reset/Lamp Test position.

Indicator Lamps: The control panel has twelve indicator lamps which are described as follows:

- RUN (green) lamp comes on when starter circuit opens after set starting.
- PRE LO OIL PRES (yellow) indicates engine oil pressure is marginally low.
- PRE HI ENG TEMP (yellow) indicates engine temperature is marginally high.
- LO OIL PRES (red) indicates engine has shut down because of critically low oil pressure.
- HI ENG TEMP (red) indicates engine has shut down because of critically high engine temperature.
- OVERSPEED (red) indicates engine has shut down because of excessive speed.
- OVERCRANK (red) indicates engine has failed to start during the cranking period.
- FAULT 1 (red) lamp indicates an undedicated fault. May be field programmed as a shutdown or non-shutdown, and as a timed or non-timed fault. (Normally set for timed shutdown).
- FAULT 2 (red) lamp indicates same features as Fault 1 (normally set for non-timed shutdown).
- LOW ENG TEMP (yellow) lamp lights if engine temperature is marginally low for starting. It may indicate an inoperative coolant heater.
- LO FUEL (yellow) (optional) indicates fuel supply pressure is marginally low (5 inches [127 mm] WC or less).
- SWITCH OFF (flashing red) indicates generator set is not in automatic start mode.

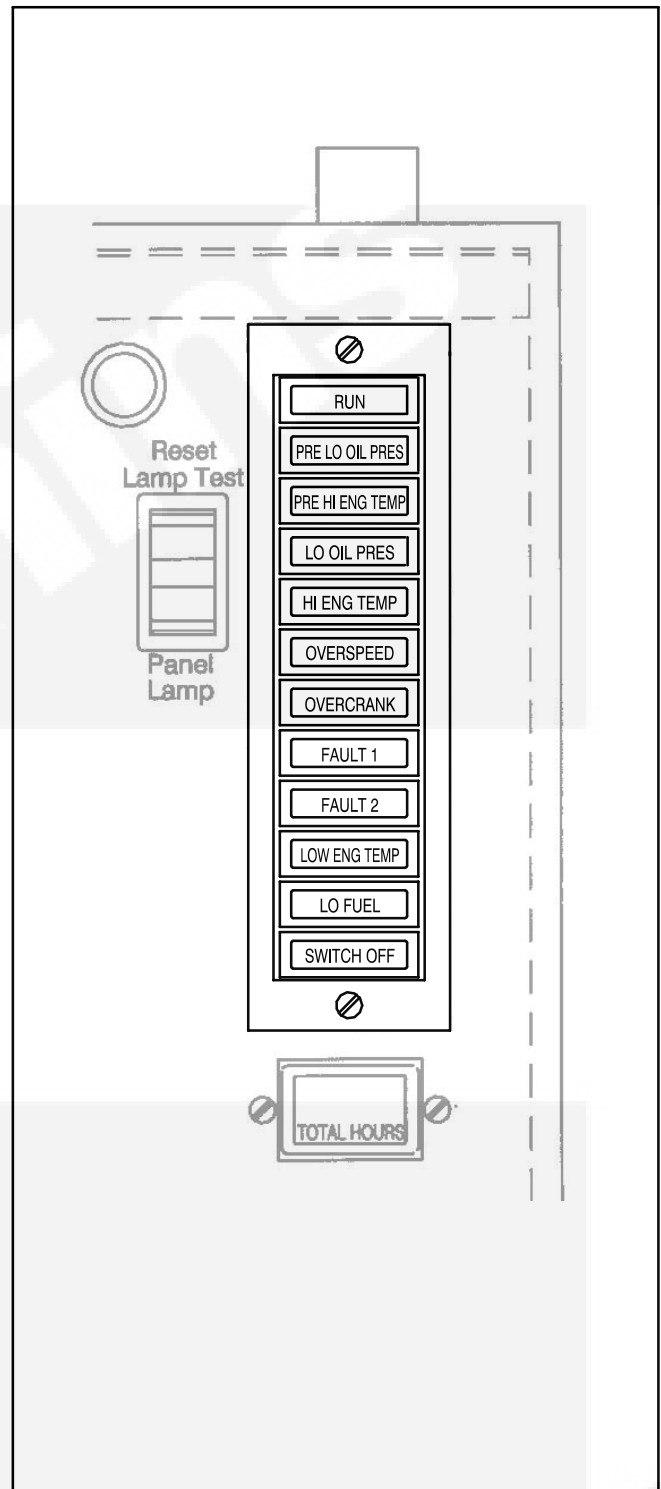

FIGURE 3-2. INDICATOR LAMPS

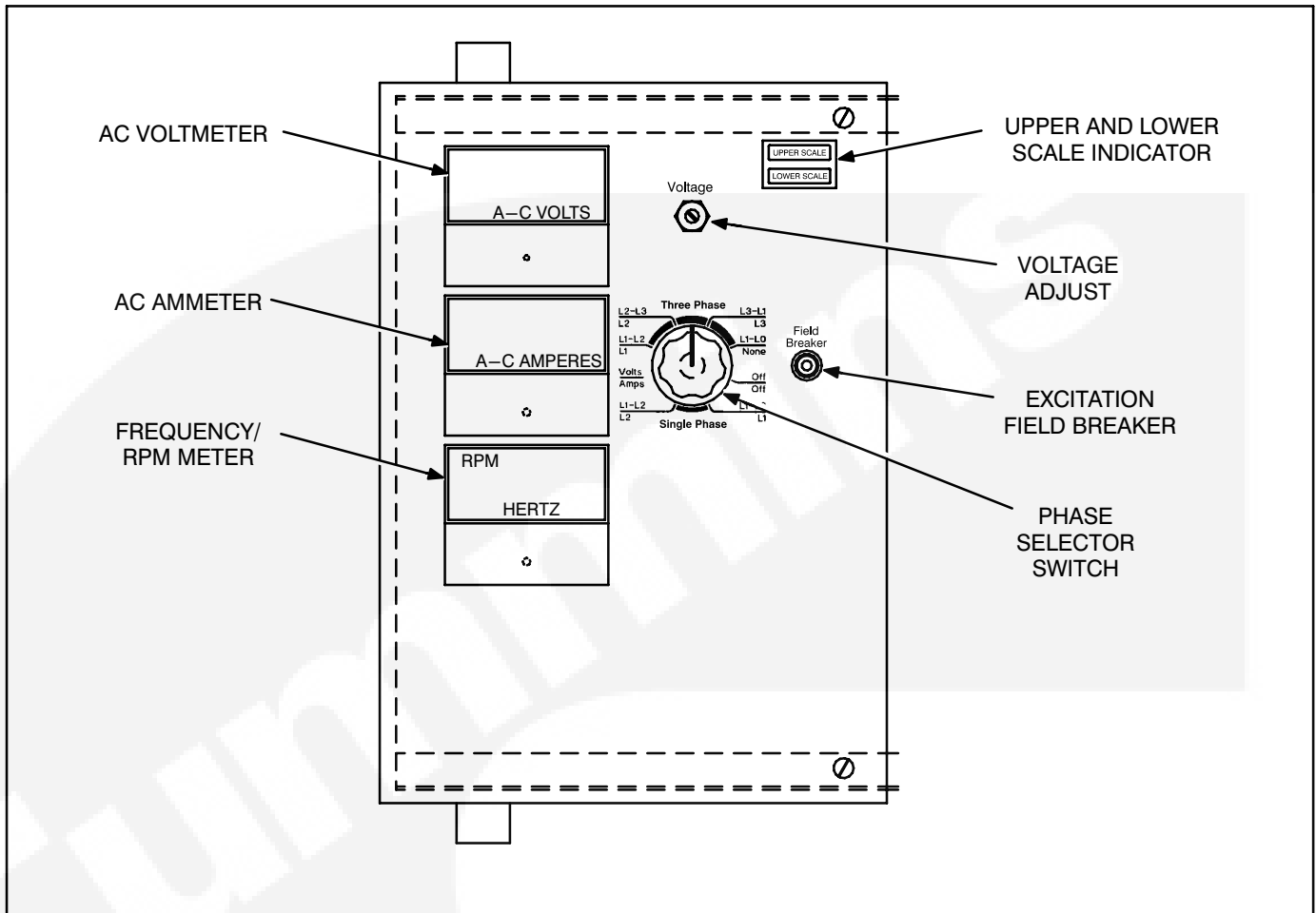

FIGURE 3-3. AC CONTROL PANEL

AC Panel

AC Voltmeter: Dual range instrument indicating AC voltage. Measurement range in use shown on indicator lamp.

AC Ammeter: Dual range instrument indicates AC generator line current.

Frequency/RPM Meter: Indicates generator output frequency in hertz and engine speed in revolutions-per-minute (RPM).

Voltage Adjusting Rheostat: Provides approximately plus or minus five percent adjustment of the rated output voltage.

Upper and Lower Scale Indicator Lamps: Indicates which scale to use on the AC voltmeter and ammeter.

Phase Selector Switch: Selects phases of generator output to be measured by AC voltmeter and ammeter.

Field Breaker: Provides generator exciter and regulator protection from overheating in the event of certain failure modes of generator, exciter and voltage regulator.

GENERATOR AC VOLTAGE REGULATOR

The solid-state regulator controls AC output voltage from the generator at a predetermined level regardless of load. Refer to the GG Series Specification Sheet for the voltage regulation and random voltage variation specifications.

ENGINE CONTROL MODULE

Electronic and relay components of the engine monitoring circuit are on a circuit board assembly. Sensor inputs are connected by the wiring harness to plug connectors on the board. The control module provides the following functions of unit protection.

- Overcrank - The standard cycle cranking feature allows three 15-second cranking cycles with two 15-second rest periods. If engine fails to start, the module lights a fault lamp and opens the cranking circuit.

The overcrank option limits engine cranking to 75 seconds. If engine fails to start, the module lights a fault lamp and opens the cranking circuit.

- Overspeed - Shuts down the engine immediately if overspeed occurs and lights a fault lamp.

For non-PMG generator sets, the sensor switch is mounted in the end bell on the generator shaft. It is factory adjusted to shut down 60 hertz units at 2100 ± 90 r/min, 50 hertz units at 1850 ± 50 r/min.

PMG generator sets, a frequency detection module, located inside the control box, monitors PMG frequency and shuts down 60 hertz units at 2100 ± 90 r/min, 50 hertz units at 1850 ± 50 r/min.

- Low Oil Pressure - Shuts down the engine immediately and lights a fault lamp if oil pressure drops below:

GGHB – 14 psi (97 kPa)

GGHC, GGHD – 25 psi (195 kPa)

The fault is time-delayed about 10 seconds following starter disconnect and inhibited during cranking. The delay allows oil pressure to rise to normal before the electronic control module monitors this system.

A pre-low oil pressure sensor and lamp provides an alarm that oil pressure is marginally low or less than:

GGHB – 20 psi (137 kPa)

GGHC, GGHD – 30 psi (207 kPa)

The cause should be found and corrected as soon as possible.

- High Engine Temperature - shuts down the engine immediately if coolant temperature rises above 230° F (110° C) and lights a fault lamp. The fault is time-delayed about 10 seconds following starter disconnect and inhibited during cranking. This delay allows coolant in a hot engine time to circulate and return the water jacket to normal before the electronic control module monitors this system.

A pre-high engine temperature sensor and lamp provides an alarm that engine temperature is marginally high, 220° F (104° C). The cause should be found and corrected as soon as possible.

⚠ CAUTION *The high engine temperature shutdown system may not operate if the coolant level is too low. The high engine temperature sensor monitors coolant temperature. Loss of coolant will prevent sensor operation and allow the engine to overheat causing severe damage to the engine. Therefore, maintain adequate coolant level for proper operation of the high engine temperature shutdown system.*

- Low Coolant Level Alarm/Shutdown (Optional) - An electronic switch that provides engine alarm or shutdown if coolant level falls too low. It also turns on the fault lamp.

STARTING

The following sections cover the three systems used to start the generator set.

Before starting the generator set, make sure that exhaust and fuel fittings are tight and properly positioned and that proper maintenance has been performed. See *Prestart Checks* in this section.

Starting at Control Panel

Move the Run-Stop-Remote switch on the DC panel to the RUN position. This will activate the engine control system and the starting system. The starter will begin cranking and after a few seconds the engine should start. The starter will disconnect when the engine reaches a speed of 450 to 570 RPM.

If the engine does not start, the starter will disengage after a specified period of time and the control will indicate an overcrank fault. Generator sets with the optional overcrank control will crank continuously for up to 75 seconds before disengaging the starter. Generator sets with the standard cycle cranking feature will crank for 15 seconds in each cycle until 3 cycles have been completed. To clear an overcrank fault, place the Run-Stop-Remote switch in the STOP position and momentarily press the Reset switch. Wait two minutes for the starter motor to cool and then repeat the starting procedure. If the engine does not run after a second attempt at starting, refer to the *Troubleshooting* section.

Starting From Remote Location

Move the Run/Stop/Remote switch on the generator set DC panel to the REMOTE position. This allows the generator set to be started from a remote switch. Closing the remote switch initiates the starting sequence described in the previous section.

Automatic Starting

Place the Run/Stop/Remote switch on the generator set DC panel in the REMOTE position if an automatic transfer switch is used. This allows the transfer switch to start the generator set if a power outage occurs and stop it when the power returns.

Cold Starting With Loads

In accordance with NFPA 110, Onan recommends installing standby generator sets (life safety systems) equipped with coolant heaters in locations

where the minimum ambient temperature is above 40°F (4°C). NFPA also requires that the engine coolant be maintained at a minimum of 90°F (32°C) and for most applications, accept the emergency load in 10 seconds or less. Although most Onan generator sets will start in temperatures below 40°F (4°C) when equipped with coolant heaters, it might take some running time to warm the engine up before a load can be applied when ambient temperatures are below 40°F (4°C).

The Low Engine Temperature (LET) lamp on the Onan Detector 12 control is provided to meet the requirements of NFPA 110. The LET sensor signals an alarm when the engine coolant temperature falls below 70°F (21°C). In applications where the ambient temperature falls below 40°F (4°C), the LET may be lit even though the coolant heaters are connected and operable. Under these conditions, although the generator set may start, it may not be able to accept load within 10 seconds. When this condition occurs, check the coolant heaters for proper operation. If the coolant heaters are operating properly, other precautions might be necessary to warm the engine before applying a load.

STOPPING

Before Stopping

Run the generator set at no load for three to five minutes before stopping. This allows the lubricating oil and engine coolant to carry heat away from the combustion chamber and bearings.

To Stop

If the set was started at the set control panel or at a remote control panel, move the Run/Stop/Remote switch or remote starting switch to the STOP position. If the set was started by an automatic transfer switch, the transfer switch will send a remote (timed delay) stop signal after the normal power source returns.

Emergency Stop

An optional emergency stop button is located on the right side of control panel (Figure 3-1). Push button in for emergency stop. To reset, pull switch out and move Run/Stop/Remote switch to Stop position. Then push test switch to Reset/Lamp Test position.

Onan automatic transfer switches have as an option an exerciser that can be preset to provide regular exercise periods. Typically the exerciser can be set for time of start, length of run, and day of week.

4. Troubleshooting (Detector Control)

The generator set has sensors that continuously monitor the engine for abnormal conditions, such as low oil pressure or high coolant temperature. If these conditions occur, the engine monitor activates a fault lamp, and may also stop the engine (depending on the condition). If the generator set is stopped for this reason, the operator may be able to restart the set after making adjustments or corrections. This section describes the fault condition system, and suggests troubleshooting procedures.

The control has a single green light to indicate RUN, four amber lights and seven red fault lights. The control also has a terminal connection for an audible alarm, that sounds when a fault occurs.

SAFETY CONSIDERATIONS

High voltages are present inside the control box and generator output box when the set is running. Do not open the control box or generator output box while the set is running.

⚠️WARNING *Contacting high voltage components can cause electrocution, resulting in severe personal injury or death. Keep control and output box covers in place during troubleshooting.*

When troubleshooting a set that is shut down, make certain the generator set cannot be accidentally restarted. Place the Run/Stop/Remote switch in the STOP position and remove the negative battery cable from the set starting battery.

⚠️CAUTION *Always disconnect a battery charger from its AC source before disconnecting the battery cables. Otherwise, disconnecting the cables can result in voltage spikes high enough to damage the DC control circuits of the set.*

⚠️WARNING *Accidental starting of the generator set while working on it can cause severe personal injury or death. Prevent accidental starting by disconnecting the starting battery cables (negative [-] first).*

Make certain battery area has been well ventilated before servicing battery, especially if a battery charger has been connected. Arcing can ignite explosive hydrogen gas given off by batteries, causing severe personal injury. Arcing can occur when cable is removed or re-attached, or when negative (-) battery cable is connected and a tool used to connect or disconnect positive (+) battery cable touches frame or other grounded metal part of the set.

When a fault lamp turns on during operation, follow the procedures listed below to locate and correct the problem. For any symptom not listed, contact an authorized service center for assistance.

Resetting the Control

The external alarm and fault lamp may be deactivated by moving the Run/Stop/Remote switch to the Stop position and pressing the Reset/Lamp Test/Panel Lamp switch. Locate the problem and correct it before restarting the set. While pressing the Reset/Lamp Test/Panel Lamp switch, make certain that all lamps light.

Line Circuit Breaker (Optional)

The optional line circuit breaker mounts on the generator output box. If the load exceeds the generator current rating, the line circuit breaker will open, preventing the generator from being overloaded. If the circuit breaker trips, locate the source of the overload and correct as necessary. Manually reset the breaker to reconnect the load to the generator.

TABLE 4-1. TROUBLESHOOTING

⚠WARNING *Many troubleshooting procedures present hazards which can result in severe personal injury or death. Only qualified service personnel with knowledge of fuels, electricity, and machinery hazards should perform service procedures. Review safety precautions on pages iii and iv.*

SYMPTOM	CORRECTIVE ACTION
1. Green RUN lamp lights following engine startup.	1. Indicates all engine systems are normal. No corrective action required.
2. PRE HI ENGINE TEMP lamp lights. Engine continues to operate.	2. Indicates engine has begun to overheat and engine temperature has risen to approximately 220°F (104°C). If generator is powering non-critical and critical loads and cannot be shut down, use the following: <ul style="list-style-type: none"> a. Reduce load if possible by turning off non-critical loads. b. Check air inlets and outlets and remove any obstructions to airflow. If engine can be stopped, follow procedure in step 3.
3. HI ENG TEMP lamp lights. Engine shuts down.	3. Indicates engine has overheated (engine temperature has risen above 230°F/110°C) or coolant level is low (sets with coolant level sensor). Allow engine to cool down completely before proceeding with the following checks: <ul style="list-style-type: none"> a. Check coolant level and replenish if low. Look for possible coolant leakage points and repair if necessary. b. Check for obstructions to cooling airflow and correct as necessary. c. Check for a slipping fan belt and tighten if loose. d. Reset control and restart after locating and correcting problem. Contact an authorized service center for service if none of the above.
4. PRE LO OIL PRES lamp lights. Engine continues to operate.	4. Indicates engine oil pressure has dropped to: <ul style="list-style-type: none"> GGHB – 20 psi (137 kPA) GGHC, GGHD – 30 psi (207 kPA) If generator is powering critical loads and cannot be shut down, wait until next shutdown period and then follow step 5 procedure. If engine can be stopped, follow procedures in step 5.

TABLE 4-1. TROUBLESHOOTING (continued)

▲WARNING *Many troubleshooting procedures present hazards which can result in severe personal injury or death. Only qualified service personnel with knowledge of fuels, electricity, and machinery hazards should perform service procedures. Review safety precautions on pages iii and iv.*

SYMPTOM	CORRECTIVE ACTION
<p>5. LO OIL PRES lamp lights. Engine shuts down. NOTE: See also step 6.</p>	<p>5. Indicates engine oil pressure has dropped to: GGHB – 14 psi (97 kPA) GGHC, GGHD – 25 psi (195 kPA) Check oil level, lines and filters. If oil system is OK but oil level is low, replenish. Reset control and restart. Contact an authorized service center if oil pressure is not in the range of 40 to 65 psi (276 to 449 kPa).</p>
<p>6. OVERCRANK lamp lights and engine stops cranking.</p> <p>or</p> <p>Engine runs, shuts down, and LO OIL PRES lamp lights..</p>	<p>6. Indicates possible fuel system problem.</p> <ol style="list-style-type: none"> a. Open any closed fuel shutoff valve. b. Check for dirty or plugged air filter and replace if necessary (see <i>Maintenance</i> section). c. Gaseous fuel delivery to the set is inadequate. Contact an authorized service center for service. d. Reset the control and restart after correcting the problem. Contact an authorized service center for service if none of the above.
<p>7. OVERSPEED lamp lights and the engine shuts down.</p>	<p>7. Indicates engine has exceeded normal operating speed. Contact an authorized service center for service.</p>
<p>8. SWITCH OFF lamp flashes.</p>	<p>8. Indicates Run/Stop/Remote switch is in the Stop position which will prevent automatic starting if an automatic transfer switch is used. Move the Run/Stop/Remote switch to the Remote position for automatic starting.</p>
<p>9. LO ENG TEMP lamp lights. Set is in standby mode but is not operating.</p> <p>(Lamp lights when engine coolant temperature is 70° F (21° C) or lower. Since the lamp goes out after the engine warms up, there should be no cause for alarm even during initial generator set operation.)</p>	<p>9. Indicates engine coolant heater is not operating, not circulating coolant or ambient temperature too cold for heater to keep up with demand. Check for the following conditions:</p> <ol style="list-style-type: none"> a. Coolant heater not connected to power supply. Check for blown fuse or disconnected heater cord and correct as required. b. Check for low coolant level and replenish if required. Look for possible coolant leakage points and repair as required. c. Contact an authorized service center for service if none of the above.

TABLE 4-1. TROUBLESHOOTING (continued)

⚠WARNING *Many troubleshooting procedures present hazards which can result in severe personal injury or death. Only qualified service personnel with knowledge of fuels, electricity, and machinery hazards should perform service procedures. Review safety precautions on pages iii and iv.*

SYMPTOM	CORRECTIVE ACTION
10. The FAULT 1 or FAULT 2 fault lamp lights. Engine shuts down immediately, engine runs for several seconds and then shuts down, or engine continues to run.	10. The standard undesignated fault functions are programmed to shut down the set when a fault is sensed. Fault 1 is time delayed while Fault 2 is immediate. The nature of the fault is an optional selection that is determined when the set installation is designed. The undesignated fault functions may also be programmed for non-shutdown or non-time delay.
11. The LOW FUEL fault lamp lights. Engine continues to run or is in standby mode.	11. Indicates fuel supply pressure is marginally low (5 inches [127 mm] WC or less). Check for partially closed shutoff valve, empty propane supply tank. For natural gas fueled sets, check with the gas utility.
12. Fault lamp lights but no fault exists. Engine gauges show oil pressure, engine temperature, and frequency (speed) are within normal limits.	12. The monitor board or a sensor may be at fault. Contact an authorized service center for service.
13. Engine starts from generator control panel but will not start automatically or from a remote panel. (Note: The Run/Stop/Remote switch must be in the Remote position for automatic or remote starting).	13. Remote circuit breaker is tripped. Reset breaker and restart. Contact an authorized service center if breaker trips after resetting.
14. Engine will not crank.	14. Indicates possible fault with control or starting system. Check for the following conditions: <ul style="list-style-type: none"> a. Fault lamp on. Correct fault and reset control. b. Poor battery cable connections. Clean the battery cable terminals and tighten all connections. c. Discharged or defective battery. Recharge or replace the battery. d. Emergency stop button (if equipped) pushed in. To reset, pull switch out and move Run/Stop/Remote switch to Stop position. Then push test switch to Reset/ Lamp position. e. Contact an authorized service center if none of the above.

TABLE 4-1. TROUBLESHOOTING (continued)

⚠WARNING *Many troubleshooting procedures present hazards which can result in severe personal injury or death. Only qualified service personnel with knowledge of fuels, electricity, and machinery hazards should perform service procedures. Review safety precautions on pages iii and iv.*

SYMPTOM	CORRECTIVE ACTION
15. No AC output voltage.	15. Field breaker is tripped. Reset breaker. Contact an authorized service center if voltage buildup causes breaker to trip.
16. RUN or fault lamp(s) does not light when Lamp Test switch is engaged.	16. Contact an authorized service center for assistance.
17. Green RUN lamp does not light following engine startup.	17. Indicates possible Start/Disconnect relay failure. Contact an authorized service center for assistance.





5. Operation (Sentinel Control)

GENERAL

This section covers prestart checks, starting and stopping and operating the generator set. Each operator should read through this entire section before attempting to start the set. It is essential that the operator be completely familiar with the set for safe operation. Refer to *Section 9* for operating recommendations.

PRESTART CHECKS

Before starting, be sure the following checks have been made and the unit is ready for operation. Refer to the *Maintenance* section for the recommended procedures.

Lubrication

Check the engine oil level. Keep the oil level as close as possible to the dipstick high mark without overfilling.

Coolant

Check the engine coolant level. The cold coolant level should be about 3/4 inch (18 mm) below the radiator cap lower sealing surface. Do not check while the engine is hot.

diator cap lower sealing surface. Do not check while the engine is hot.

⚠WARNING *Contact with hot coolant can result in severe burns. Do not bleed hot, pressurized coolant from a closed cooling system.*

Fuel

Check the fuel supply and open all manual shutoff valves in the fuel supply system.

Exhaust

Check to make sure entire exhaust system is tight, that no combustible materials are near system, and gases are discharged away from building openings.

CONTROL PANEL

The following describes the function and operation of the Sentinel control. All instruments and control switches are located on the face of the control panel as illustrated in Figure 5-1.

EXHAUST GAS IS DEADLY!

Exhaust gases contain carbon monoxide, an odorless and colorless gas. Carbon monoxide is poisonous and can cause unconsciousness and death. Symptoms of carbon monoxide poisoning can include:

- ***Dizziness***
- ***Nausea***
- ***Headache***
- ***Weakness and Sleepiness***
- ***Throbbing in Temples***
- ***Muscular Twitching***
- ***Vomiting***
- ***Inability to Think Coherently***

IF YOU OR ANYONE ELSE EXPERIENCE ANY OF THESE SYMPTOMS, GET OUT INTO THE FRESH AIR IMMEDIATELY. If symptoms persist, seek medical attention. Shut down the unit and do not operate until it has been inspected and repaired.

Protection against carbon monoxide inhalation includes proper installation and regular, frequent visual and audible inspections of the complete exhaust system.

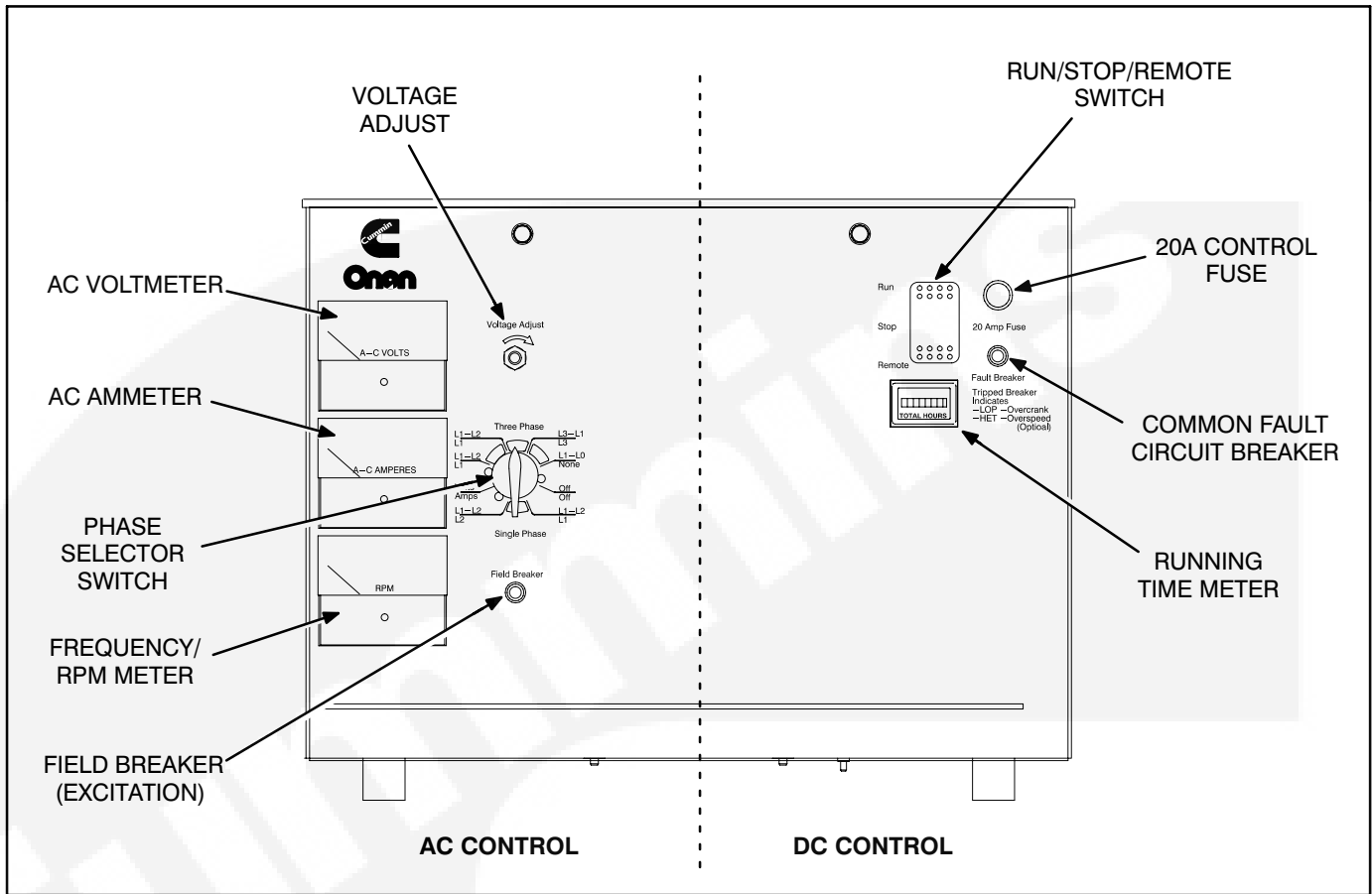

FIGURE 5-1. SENTINEL CONTROL PANEL

DC Control

Run/Stop/Remote Switch: Starts and stops the set locally, or from a remote location wired to the control.

Running Time Meter: Registers the total number of hours the unit has run. Use it to keep a record of periodic servicing. Time is cumulative; meter cannot be reset.

20A Control Fuse: Protects control components and wiring from current overload.

Common Fault Circuit Breaker: The common fault circuit breaker shuts down the engine when any fault shutdown sensor activates. Fault shutdown is indicated when the breaker reset button extends out past normal. Push the button to restore operation (after the engine has been properly serviced).

The standard fault shutdowns are low oil pressure, high engine temperature or overcrank. Overspeed is optional.

AC Control

AC Voltmeter (Optional): Dual range instrument indicating AC voltage. Measurement range in use shown on indicator lamp.

AC Ammeter (Optional): Dual range instrument indicates AC generator line current.

Frequency/RPM Meter (Optional): Indicates generator output frequency in hertz and engine speed in revolutions-per-minute (RPM).

Voltage Adjusting Rheostat (Optional): Provides approximately plus or minus five percent adjustment of the rated output voltage.

Phase Selector Switch (Optional): Selects phases of generator output to be measured by AC voltmeter and ammeter.

Field Breaker (Excitation): Provides generator exciter and regulator protection from overheating in the event of certain failure modes of generator, exciter and voltage regulator.

GENERATOR AC VOLTAGE REGULATOR

The solid-state regulator controls AC output voltage from the generator at a predetermined level regardless of load. Refer to the GG Series Specification Sheet for the voltage regulation and random voltage variation specifications.

ENGINE MONITORING

Electronic and relay components of the engine monitoring circuit are mounted inside the control box. An optional Dry Contact Module (DCM) can also be installed in the control box to enable remote monitoring of these components. The components provide the following functions of unit protection.

Note: Refer to the *Installation Manual* for a functional description of the Dry Contact Module option.

- Overcrank - Limits engine cranking to 60 seconds. If engine fails to start, the Fault Breaker trips and opens the cranking circuit.
- Overspeed (optional) - Shuts down the engine immediately and trips the common fault circuit breaker if overspeed occurs. The sensor switch is mounted in the end bell on the generator shaft for non-PMG sets. PMG sets, a frequency detection module, located inside the control box, monitors PMG frequency. The shut down limits are: 60 hertz units at 2100 ± 90 r/min, 50 hertz units at 1850 ± 50 r/min.
- Low Oil Pressure - Shuts down the engine immediately and trips the common fault circuit breaker if oil pressure drops below:
GGHB – 14 psi (97 kPA)
GGHC, GGHD – 25 psi (195 kPA)
The fault is time-delayed about 10 seconds following starter disconnect and inhibited during cranking. The delay allows oil pressure to rise to normal before the electronic control module monitors this system.
- High Engine Temperature - Shuts down the engine immediately if coolant temperature rises above 230° F (110° C) and trips the common fault circuit breaker. Fault condition cannot be cleared until sensor detects coolant temperature of lower than 220° F (104° C).

- Low Coolant Level (optional w/DCM) - Shuts down the engine immediately if coolant level falls too low. Fault condition cannot be cleared until sensor detects coolant in radiator.
- Low Fuel Pressure (optional w/DCM) - Indicates fuel supply pressure is marginally low (5 inches [127 mm] WC or less). Used only in single fuel systems. (Remote panel must be attached to control to monitor this error.)

⚠ CAUTION *The high engine temperature shutdown system may not operate if the coolant level is too low. The high engine temperature sensor monitors coolant temperature. Loss of coolant will prevent sensor operation and allow the engine to overheat causing severe damage to the engine. Therefore, maintain adequate coolant level for proper operation of the high engine temperature shutdown system.*

STARTING

The following sections cover the three systems used to start the generator set.

Before starting the generator set, make sure that exhaust and fuel fittings are tight and properly positioned and that proper maintenance has been performed. See *Prestart Checks* in this section.

Starting at Control Panel

Move the Run-Stop-Remote switch on the DC panel to the RUN position. This will activate the engine control system and the starting system. The starter will begin cranking and after a few seconds the engine should start. The starter will disconnect when the engine reaches a speed of 450 to 570 RPM.

If the engine does not start, the starter will disengage after 60 seconds and the control will indicate an overcrank fault. To clear an overcrank fault, place the Run-Stop-Remote switch in the STOP position and reset the common fault circuit breaker. Wait two minutes for the starter motor to cool and then repeat the starting procedure. If the engine does not run after a second attempt at starting, refer to the *Troubleshooting (Sentinel Control)* section.

Starting From Remote Location

Move the Run/Stop/Remote switch on the generator set DC panel to the REMOTE position. This allows the generator set to be started from a remote switch. Closing the remote switch initiates the starting sequence described in the previous section.

Automatic Starting

Place the Run/Stop/Remote switch on the generator set DC panel in the REMOTE position if an automatic transfer switch is used. This allows the transfer switch to start the generator set if a power outage occurs and stop it when the power returns.

Cold Starting With Loads

Change the engine oil if it is not of the viscosity recommended for the ambient temperature (Figure 7-1).

To prevent engine coolant from freezing, make sure the coolant is a 50/50 mixture of anti-freeze and water.

Engine coolant heaters are available for easier starting in cold weather. Make sure the voltage of the separate power source is correct for the coolant heater element rating.

CAUTION *To avoid damage to the coolant heater, make sure the cooling system is full before applying power to the heater.*

STOPPING

Before Stopping

Run the generator set at no load for three to five minutes before stopping. This allows the lubricating oil and engine coolant to carry heat away from the combustion chamber and bearings.

To Stop

If the set was started at the set control panel or at a remote control panel, move the Run/Stop/Remote switch or remote starting switch to the STOP position. If the set was started by an automatic transfer switch, the transfer switch will send a remote (timed delay) stop signal after the normal power source returns.



6. Troubleshooting (Sentinel Control)

The generator set has sensors that continuously monitor the engine for abnormal conditions, such as low oil pressure or high coolant temperature. If these conditions occur, the common fault circuit breaker trips, and the engine shuts down. After the problem is corrected, reset the common fault circuit breaker to restart the generator set. This section describes the fault condition system, and suggests troubleshooting procedures.

SAFETY CONSIDERATIONS

High voltages are present inside the control box and generator output box when the set is running. Do not open the control box or generator output box while the set is running.

⚠️WARNING *Contacting high voltage components can cause electrocution, resulting in severe personal injury or death. Keep control and output box covers in place during troubleshooting.*

When troubleshooting a set that is shut down, make certain the generator set cannot be accidentally restarted. Place the Run/Stop/Remote switch in the STOP position and remove the negative battery cable from the set starting battery.

⚠️CAUTION *Always disconnect a battery charger from its AC source before disconnecting the battery cables. Otherwise, disconnecting the cables can result in voltage spikes high enough to damage the DC control circuits of the set.*

⚠️WARNING *Accidental starting of the generator set while working on it can cause severe personal injury or death. Prevent accidental starting by disconnecting the starting battery cables (negative [-] first).*

Make certain battery area has been well ventilated before servicing battery, especially if a battery charger has been connected. Arcing can ignite explosive hydrogen gas given off by batteries, causing severe personal injury. Arcing can occur when cable is removed or re-attached, or when negative (-) battery cable is connected and a tool used to connect or disconnect positive (+) battery cable touches frame or other grounded metal part of the set.

When a fault condition occurs during operation, follow the procedures in Table 6-1 to locate and correct the problem. For any symptom not listed, contact an authorized service center for assistance.



TABLE 6-1. TROUBLESHOOTING

⚠WARNING *Many troubleshooting procedures present hazards which can result in severe personal injury or death. Only qualified service personnel with knowledge of fuels, electricity, and machinery hazards should perform service procedures. Review safety precautions on pages iii and iv.*

SYMPTOM	CORRECTIVE ACTION
<p>1. Engine will not crank.</p>	<p>1. Indicates possible fault with control or starting system. Check for the following conditions:</p> <ul style="list-style-type: none"> a. Correct fault and reset common fault circuit breaker. b. Poor battery cable connections. Clean the battery cable terminals and tighten all connections. c. Discharged or defective battery. Recharge or replace the battery. d. Replace the control circuit fuse (located inside the control panel) if it has blown.
<p>2. The engine cranks, but does not start.</p>	<p>2. Indicates possible fuel system problem.</p> <ul style="list-style-type: none"> a. Check for empty fuel tank, fuel leaks, or plugged fuel lines and correct as required. b. Check for dirty or plugged air filter and replace if necessary (see <i>Maintenance</i> section). c. Reset the tripped common fault circuit breaker and restart after correcting the problem. Contact an authorized service center for service if none of the above.
<p>3. The engine shuts down due to high engine temperature or low coolant level. The Fault Shutdown is being indicated by the fault circuit breaker reset button (extended out).</p>	<p>3. Indicates engine has overheated (engine temperature has risen above 230° F/110° C). Allow engine to cool down completely before proceeding with the following checks:</p> <ul style="list-style-type: none"> a. Check coolant level and replenish if low. Look for possible coolant leakage points and repair if necessary. b. Check for obstructions to cooling airflow and correct as necessary. c. Check for a slipping fan belt and tighten if loose. d. Reset the tripped common fault circuit breaker. Contact an authorized service center for service if none of the above.

TABLE 6-1. TROUBLESHOOTING (continued)

⚠WARNING *Many troubleshooting procedures present hazards which can result in severe personal injury or death. Only qualified service personnel with knowledge of fuels, electricity, and machinery hazards should perform service procedures. Review safety precautions on pages iii and iv.*

SYMPTOM	CORRECTIVE ACTION
<p>4. Engine shuts down due to low oil pressure. The Fault Shutdown is being indicated by the fault circuit breaker reset button (extended out).</p>	<p>4. Indicates engine oil pressure has dropped to: GGHB – 14 psi (97 kPa) GGHC, GGHD – 25 psi (195 kPa) Check oil level, lines and filters. If oil system is OK but oil level is low, replenish. Reset the tripped common fault circuit breaker. Contact an authorized service center if oil pressure is not in the range of 40 to 65 psi (276 to 449 kPa).</p>
<p>5. The engine shuts down due to overspeed. The Fault Shutdown is being indicated by the fault circuit breaker reset button (extended out).</p>	<p>5. Indicates engine has exceeded normal operating speed. Contact an authorized service center for service.</p>
<p>6. The engine shuts down due to low coolant level. The Fault Shutdown is being indicated by the fault circuit breaker reset button (extended out).</p>	<p>6. Indicates low coolant level. Replenish coolant and look for possible coolant leakage points and repair as required.</p>
<p>7. The engine shuts down due any of five faults but remote monitor device does not detect fault.</p>	<p>7. Indicates possible fault with control or external wiring.</p>
<p>8. Engine starts from generator control panel but will not start automatically or from a remote panel. (Note: The Run/Stop/Remote switch must be in the Remote position for automatic or remote starting).</p>	<p>8. Remote circuit breaker is tripped. Reset breaker and restart. Contact an authorized service center if breaker trips after resetting.</p>





7. Maintenance

GENERAL

Establish and adhere to a definite schedule for maintenance and service based on the application and severity of the environment. The table below covers the recommended service intervals for a generator set on STANDBY service. If the set will be subjected to extreme operating conditions, the service intervals should be reduced accordingly. Some of the factors that can affect the maintenance schedule are the following:

- Use for continuous duty (prime power)
- Extremes in ambient temperature
- Exposure to elements
- Exposure to salt water
- Exposure to windblown dust or sand.

Consult with an authorized Onan Distributor if the generator set will be subjected to any extreme operating conditions and determine a suitable schedule of maintenance. Use the running time meter to keep an accurate log of all service performed for warranty support. Perform all service at the time period indicated or after the number of operating hours indicated, whichever comes first. Use Table 7-1 to determine the maintenance required and then refer to the sections that follow for the correct service procedures.

⚠️WARNING *Accidental starting of the set while performing maintenance procedures can cause serious personal injury or death. Place the Run-Stop-Remote switch in the Stop position, disconnect battery charger from its AC source and disconnect the negative(-) battery cable from the battery terminal before beginning maintenance procedures.*



TABLE 7-1. PERIODIC MAINTENANCE SCHEDULE

MAINTENANCE ITEMS	OPERATIONAL FREQUENCY - HOURS			
	10	100	200	Yearly
General Set Inspection.	x ¹			
Check engine oil level	x ¹			
Check radiator coolant level	x ¹			
Check air cleaner (clean or replace as necessary)		x ²		
Check battery electrolyte level		x ³		
Check governor linkage		x ²		
Change engine oil and filter		x ²		
Check all hardware (fittings, clamps, fasteners, etc.)		x ⁴		
Drain exhaust condensate trap		x		
Adjust drive belt tension			x ⁵	
Inspect or replace spark plugs			x	
Inspect coolant hoses and clamps			x ⁶	
Inspect coolant heater hoses			x ⁶	
Check coolant anti-freeze protection			x	
Check AC generator and controls			x	
Clean cooling system				x

- x¹ - As noted or after every run.
- x² - Perform more often in extremely dusty conditions
- x³ - Or every two weeks.
- x⁴ - Or every three months.
- x⁵ - Adjust to 1/2-inch (12.5 mm) depression between pulleys.
- x⁶ - Replace if hard or brittle.



GENERATOR SET INSPECTION

During operation, be alert for mechanical problems that could create unsafe or hazardous conditions. The following sections cover several areas that should be frequently inspected for continued safe operation.

Exhaust System

With the generator set operating, inspect the entire exhaust system visually and audibly, including the exhaust manifold, muffler, and exhaust pipe. Check for leaks at all connections, welds, gaskets, and joints and also make sure that exhaust pipes are not heating surrounding areas excessively. If any leaks are detected, shut down the generator set and have leaks corrected immediately.

⚠️WARNING *Inhalation of exhaust gases can result in serious personal injury or death. Be sure deadly exhaust gas is piped outside and away from windows, doors or other inlets to building.*

Fuel System

With the generator set operating, inspect the fuel supply lines, filters, and fittings for leaks. Check any flexible sections for cuts, cracks and abrasions and make sure they are not rubbing against anything that could cause breakage. If any leaks are detected, shut off fuel supply valves, shut down generator set and have them corrected immediately.

⚠️WARNING *Ignition of fuel can cause severe personal injury or death by fire or explosion. Do not permit any flame, cigarette, pilot light, arcing switch or equipment, or other ignition source near the fuel system.*

AC Electric System

Check the following while the generator set is operating; otherwise measure load lines L1, L2 and L3 using the appropriate AC meter.

Frequency Meter: The generator frequency should be stable and the reading should be the same as the nameplate rating.

AC Voltmeter: Turn the phase selector switch to each line-to-line phase selection shown on the volts scale (L1-L2, L2-L3, and L3-L1). Read the AC voltmeter using the upper or lower scale as indicated by the scale indicator light. At no load, the line-to-line voltage(s) should be the same as the set nameplate rating.

AC Ammeter: Turn the phase selector switch to each phase selection shown on the amps scale (L1, L2 and L3). Read the ammeter using the upper or lower scale as indicated by the scale indicator light. At no load, the current readings should be zero. With a load applied, each line current should be about the same.

Fault Lamps: Push the Reset/Lamp switch on the control panel. All indicator lamps should light. Confirm that all of the bulbs are on, then release the switch. Have any bulbs that are burned out replaced.



DC Electrical System

Check the terminals on the battery for clean and tight connections. Loose or corroded connections create resistance which can hinder starting. Clean and reconnect the battery cables if loose. Always disconnect both ends of the negative battery cable. Reconnect one end of the cable to the negative battery terminal and the other end to ground. Following this sequence will help to reduce arcing at the battery.

⚠ CAUTION *Always disconnect a battery charger from its AC source before disconnecting the battery cables. Otherwise, disconnecting the cables can result in voltage spikes high enough to damage the DC control circuits of the set.*

⚠ WARNING *Accidental starting of the generator set while working on it can cause severe personal injury or death. Prevent accidental starting by disconnecting the starting battery cables (negative [-] first).*

Make certain battery area has been well ventilated before servicing battery, especially if a battery charger has been connected. Arcing can ignite explosive hydrogen gas given off by batteries, causing severe personal injury. Arcing can occur when cable is removed or re-attached, or when negative (-) battery cable is connected and a tool used to connect or disconnect positive (+) battery cable touches frame or other grounded metal part of the set.

Mechanical

With the generator set stopped, check for loose belts and fittings, leaking gaskets and hoses, or any signs of mechanical damage. If any problems are found, have them corrected immediately. With the set running, listen for any unusual noises that may indicate mechanical problems and check the oil pressure frequently. Investigate anything that indicates possible mechanical problems.



LUBRICATION SYSTEM

Before the initial start, check dipstick to be sure crankcase is filled with oil. See *Specifications* section for lubricating oil capacity.

Generator sets are shipped with oil and coolant added. Be sure to check these systems to make sure they are at proper operating levels before starting.

Oil Recommendations

Refer to Figure 5-1 for the recommended oil viscosity grades at various ambient temperatures. Oils must conform to the American Petroleum Institute (API) classification SH or SH/CD. When selecting the oil viscosity, pick the grade that is right for the lowest temperature expected. Oil that is too thick can result in a lack of lubrication when the engine is started. If the ambient temperature is consistently below -13°F (-25°C), use a SAE5W synthetic oil.

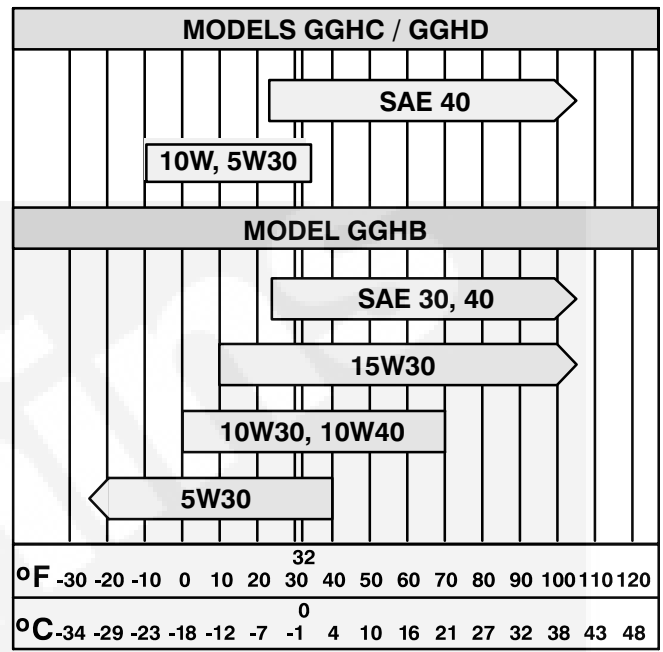

FIGURE 5-1. OIL VISCOSITY

Engine Oil Level

Check the engine oil level during engine shutdown periods at the intervals specified in the Maintenance Table. The dipstick is stamped with FULL and ADD to indicate the level of oil in the crankcase. For accurate readings, shut off the engine and wait approximately 10 minutes before checking the engine oil level. This allows oil in the upper portion of the engine to drain back into the crankcase.

Keep the oil level as near as possible to the FULL mark on the dipstick. Remove the oil fill cap and add oil of the same quality and brand when necessary.

⚠ CAUTION *Do not operate the engine with the oil level below the ADD mark or above the FULL mark. Overfilling can cause foaming or aeration of the oil. Operation below the ADD mark can cause loss of oil pressure.*

Engine Oil Change

⚠ WARNING *State or federal agencies have determined that contact with used engine oil can cause cancer or reproductive toxicity. Take care to limit skin contact and the breathing of its vapors. Use rubber gloves and wash exposed skin.*

Run engine until thoroughly warm before draining oil. Stop the set, place a pan under the drain outlet and remove the oil drain plug or open the drain valve. After the oil is completely drained, replace the drain plug or close the drain valve. Refill with oil of the correct API viscosity grade for the temperature conditions.

⚠ WARNING *Hot crankcase oil can cause burns if it is spilled or splashed on skin. Keep fingers and hands clear when removing the oil drain plug and wear protective clothing.*

Oil Filter Change

Spin off oil filter and discard it in accordance with local environmental regulations. Thoroughly clean filter mounting surface. Apply a thin film of oil to filter gasket and install new element. Spin element on by hand until gasket just touches mounting pad and then turn an additional 1/2 to 3/4 turn. Do not over-tighten (Figure 7-3).

With oil in crankcase, start engine and check for leaks around filter element. Retighten only as much as necessary to eliminate leaks but do not over-tighten.

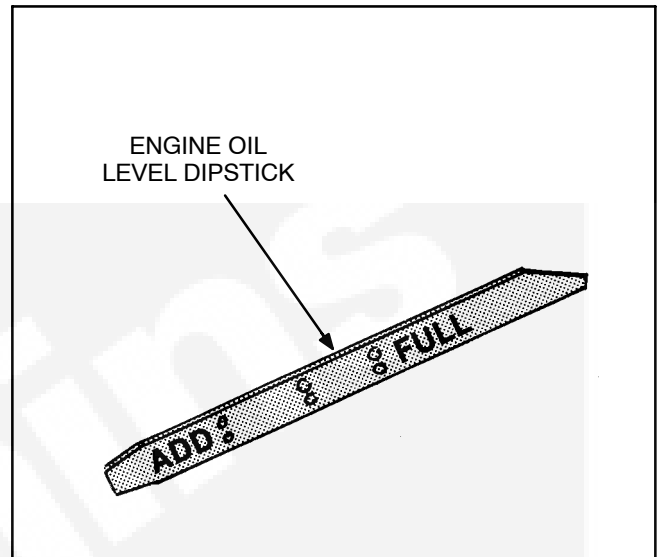

FIGURE 7-2. OIL LEVEL DIPSTICK

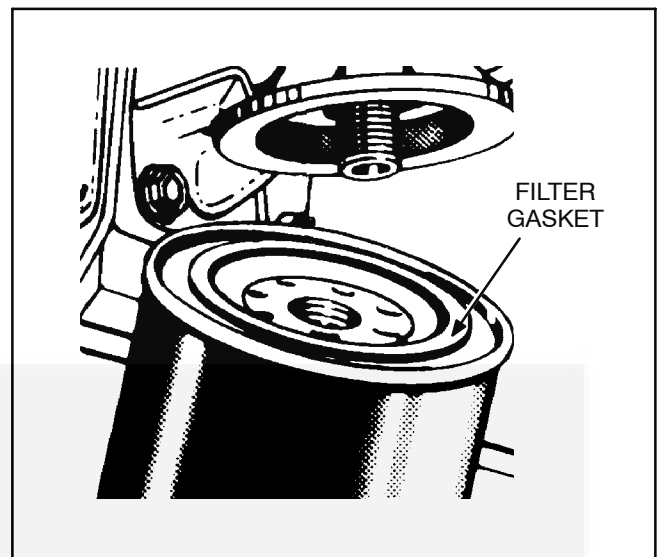

FIGURE 7-3. ENGINE OIL FILTER

COOLING SYSTEM

The cooling system capacity of a standard unit with set mounted radiator is shown in Specifications section.

Generator sets are shipped with oil and coolant added. Be sure to check these systems to make sure they are at proper operating levels before starting.

Coolant Requirements

Satisfactory engine coolant inhibits corrosion and if necessary protects against freezing. Use a 50/50 coolant solution (50% pure water and 50% anti-freeze). If temperatures below -37° F (-38° C) are possible, use a mixture of 65% antifreeze and 35% water. Do not use an antifreeze that contains anti-leak additives.

The water used for engine coolant should be clean, low in mineral content and free of any corrosive chemicals such as chloride, sulfate or acid. Use soft water. Well water often contains lime and other materials which eventually can clog the radiator core and reduce the cooling efficiency and can also cause heater element failure.

Filling the Cooling System

Check to make sure that all drain cocks are closed and all hose clamps secure. Remove the radiator pressure cap and slowly fill the cooling system with the recommended coolant.

⚠ CAUTION *Never pour hot water into a cold engine or cold water into a hot engine. Doing so can crack a head or cylinder block. Do not operate the generator set without water for even a few minutes.*

When the engine is first started, remove the pressure cap and monitor the coolant level. As trapped air is expelled from the system, the coolant level may drop and additional coolant must be added. Replace the pressure cap when the coolant level is stable.

Coolant Level

Check the coolant level during shutdown periods at the intervals shown in Table 7-1. Remove the radiator cap after allowing the engine to cool and if necessary, add coolant until the level is near the top of the radiator.

⚠ WARNING *Contact with hot coolant can result in severe burns. Allow cooling system to cool before releasing pressure and removing radiator cap.*

⚠ CAUTION *High Engine Temperature Cutoff will shut down engine in an overheat condition only if coolant is sufficiently high to physically contact shutdown switch. Loss of coolant will allow engine to overheat without protection of shutdown device and cause severe damage to the engine. It is therefore imperative that adequate engine levels be maintained to provide operational integrity of the cooling system and for engine coolant overheat shutdown protection.*



Draining and Flushing

⚠ WARNING *Some coolant is toxic. Keep away from children and animals. Follow local environmental regulations for disposal.*

To maintain adequate corrosion protection and remove rust and scale deposits, drain and flush radiator at the recommended interval.

⚠ CAUTION *The heater element will burn out if engine coolant is removed with heater connected to power source.*

Disconnect engine coolant heater from power source (if equipped).

Allow the engine to cool and then remove radiator pressure cap. Open the radiator drain cock and remove the water drain plugs (one on each side of engine). When the coolant is drained, place the end of a water hose into the radiator filler and turn on water supply. Regulate the flow of water into the radiator until it is equal to the outflow from drain openings. Continue flushing until outflow from drains is clear of rust sediment.

If engine is equipped with engine coolant heater, drain coolant by removing hose and clamp from bottom of heater.

Replace the water drain plugs and close the radiator drain cock when flushing is complete. Refill the cooling system with the recommended coolant (refer to *Filling the Cooling System*).

With cooling system properly filled and the engine has been run, connect heater plug to receptacle.

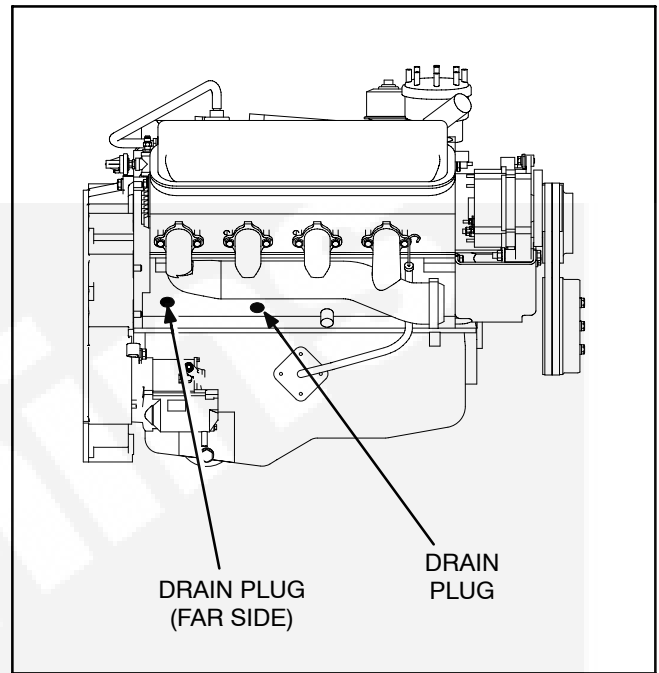

FIGURE 7-4. DRAIN PLUG LOCATIONS

AIR FILTER

Remove wing nut in center of filter cover. Remove cover and filter. Tap filter on a flat surface to remove dirt. Place a light source inside filter and inspect for air passage. If necessary, apply a low pressure air source (30 psi) to the inside of filter to remove as much dirt as possible. Inspect interior housing. Vacuum clean if dirty or remove housing and wipe clean.

⚠ CAUTION *Do not clean filter housing while still installed. Loose dirt entering intake could damage carburetor or engine.*

Clean air filter every 100 hours of operational time, more often in extremely dusty conditions. Replace air filter after 500 hours of operational time.

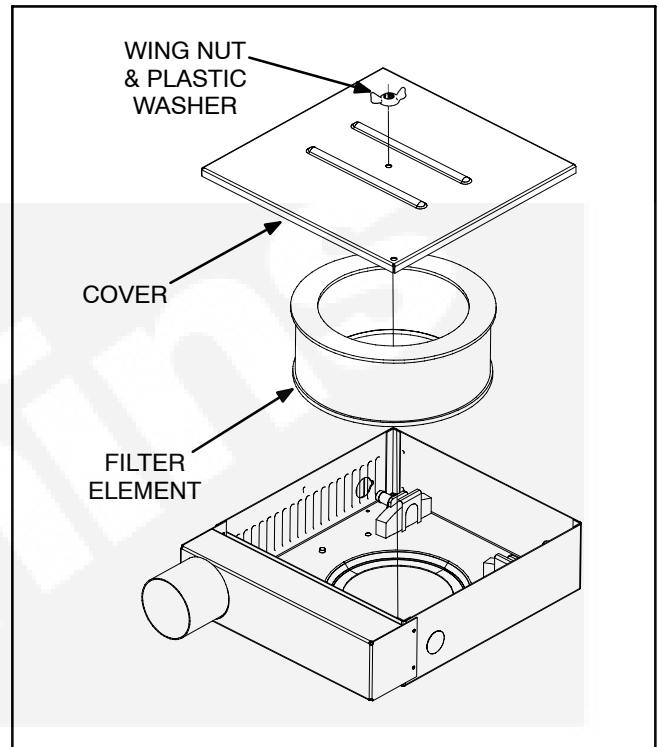

FIGURE 7-5. AIR CLEANER (NATURALLY ASPIRATED FUEL SYSTEM)

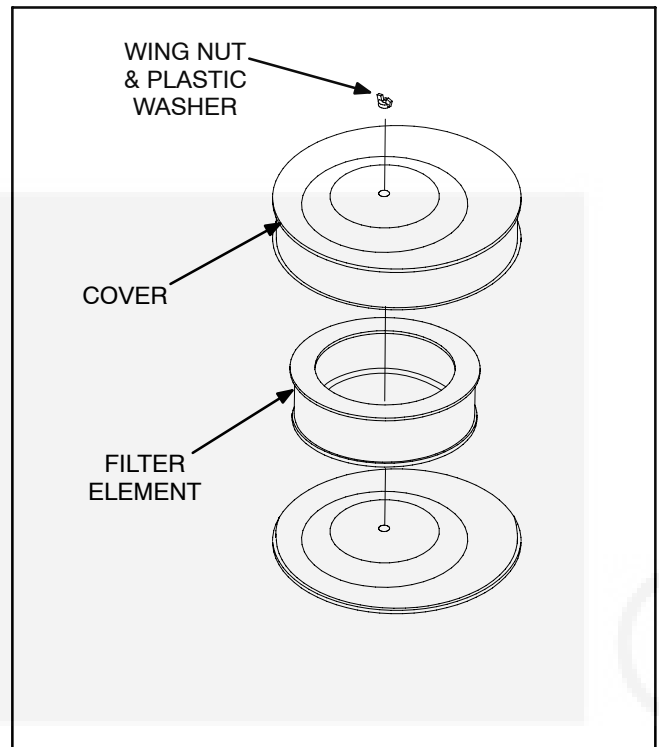

FIGURE 7-5. AIR CLEANER (TURBOCHARGED FUEL SYSTEM)

DRIVE BELT

A worn or improperly adjusted drive belt can cause engine overheating and insufficient battery charging. Before inspecting or adjusting the drive belt, disconnect the battery (negative [-] cable first) to prevent accidental starting.

Check the drive belt at the recommended interval. Remove the belt guard and inspect the belt for cracks, fraying, or glazing. Replace when necessary.

⚠WARNING *Accidental starting can cause severe personal injury or death. To prevent accidental starting, place the Run/Stop/Remote switch in the Stop position and disconnect the negative (-) battery cable from the battery before working on the generator set.*

Arcing can ignite battery gases and cause severe personal injury and can cause voltage spikes that can damage generator set control circuits. to reduce arcing:

Never disconnect the battery cables while the genset is cranking or running.

Always disconnect a battery charger from its AC source before disconnecting the battery cables.

Always disconnect the negative (-) cable first and reconnect it last. (this prevents arcing if the tool on the positive terminal touches grounded metal.)

To check belt tension, remove the belt guard and push the fan belt midway between the two pulleys shown in Figure 7-6. Use a spring balance to measure force (F) and a straight edge and ruler to measure belt deflection (d). Belt deflection should be 3/16 inch (4.8 mm) under a force of 5.0 pounds (22.0 N).

To adjust belt tension, loosen the two bolts on the battery charging alternator and adjust until proper tension is obtained. Recheck belt tension after rotating the engine so that the belt has travelled at least once around the pulleys. Retighten the alternator bolts after adjustment, reinstall the belt guard and reconnect the battery (negative[-] cable last).

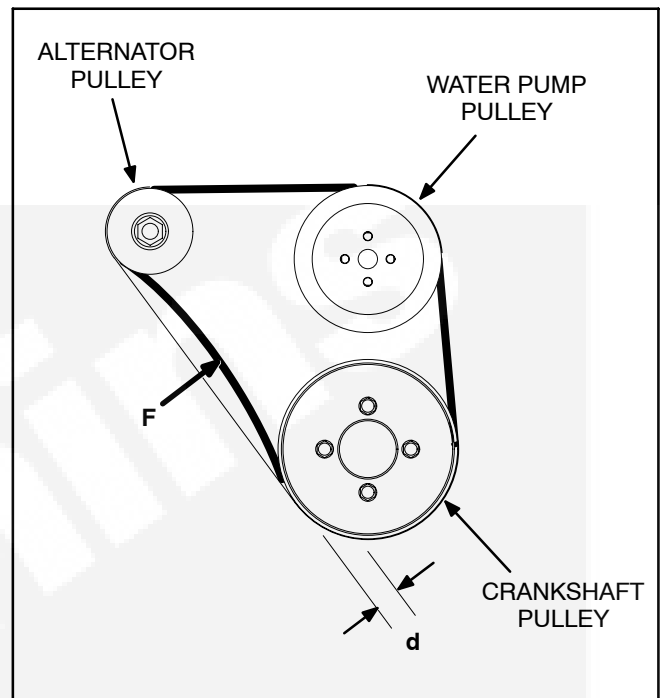

FIGURE 7-6. DRIVE BELT ADJUSTMENT

IGNITION SYSTEM

The ignition system consists of the distributor, ignition coil, high tension wires, spark plugs and electronic control module. Maintenance consists of periodic inspections to detect possible problems and replacement of worn or deteriorated parts. The ignition system must be completely functional or the set may run poorly or be unable to carry full load. Perform the following inspections at recommended intervals.

Distributor Cap

Remove the distributor cap and inspect the inside for cracks, burn marks, deterioration of the carbon button or eroded terminals. Replace the cap if any of these conditions are noted.

Rotor

While the distributor cap is removed, inspect the rotor for cracks, excessive burning of the tip, deterioration of the center spring terminal. Replace the rotor if any of these conditions are noted.

Spark Plugs

Remove the spark plugs and inspect for damaged or cracked insulators, worn electrodes, damaged gaskets or excessive carbon deposits. Replace the spark plug if any of these conditions are noted. Clean those plugs that can be reused and regap (Figure 7-7) to the amount specified in the Speci-

cations section. Clean all dirt and grit away from the spark plug seats before installing plugs.

If the spark plugs show any of the following conditions, the engine may require additional service. Contact your authorized service distributor for help.

- Carbon Fouled - Overly Rich Mixture
- Oil Fouled - High oil consumption
- Burned - Excessive engine temperature

High Tension Wires

Check the spark plug wires and coil wire for good contact at the coil, distributor cap and spark plugs. Terminal connections should be tight and fully seated. All spark plug covers and cable end boots should be in good condition and fit tightly. There should be no breaks or cracks in the insulation. Replace the wire if any of these conditions are noted.

⚠ CAUTION *High tension wires can be damaged if removed incorrectly from terminals. Grasp wire by spark plug boot to prevent damage to conductor.*

Ignition Coil

Clean the top of the ignition coil and check for cracks, carbon tracks or corrosion in the high tension terminal hole. Replace the coil if any of these conditions are noted.

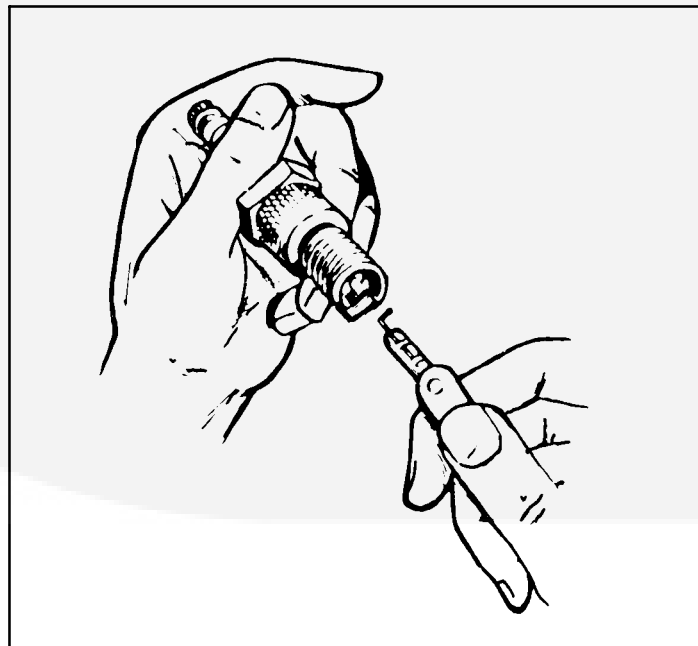

FIGURE 7-7. GAPPING SPARK PLUGS

BATTERY

Check the battery every month or at least every 100 operating hours. Add distilled water as necessary and check specific gravity. Recharge the battery if the specific gravity is less than 1.260. Clean and tighten the battery terminals and cable connectors and coat with Vaseline to retard corrosion.

⚠WARNING *Ignition of explosive battery gases can cause severe personal injury. Do not smoke. Wear goggles and protective, rubber gloves and apron when servicing batteries.*

OUT-OF-SERVICE PROTECTION

When the set will be stored or removed from operation for an extended period of time, take the following precautions to prevent rust accumulation, corrosion of bearing surfaces within the engine and gum formation in the fuel system. Perform the following procedures as outlined in this manual.

Preparing Set for Storage

1. Exercise the set as described in Operation section until the engine is up to operating temperature.
2. Shut down the engine.
3. Turn off and disconnect battery charger (if equipped).
4. Disconnect battery (negative [-] first) and store in a cool, dry place. Connect battery to charger every 30 days to maintain it at full charge.
5. Drain the engine oil while still warm and refill with new oil recommended for set. Attach a tag indicating type of oil used.
6. Remove the spark plugs and pour two ounces of rust preventative oil into each spark plug opening. Crank the set for five seconds to dis-

tribute the oil on the cylinder walls and then replace the spark plugs.

7. Disconnect engine coolant heater from power source (if equipped).
8. Drain the cooling system including the engine block.
9. Remove the air cleaner and seal off the carburetor air inlet opening and PVC hose.
10. Plug the exhaust outlets to prevent entrance of moisture, bugs, dirt, etc.
11. Clean and wipe entire unit. Coat parts susceptible to rust with a light coat of oil. Cover entire set loosely after engine has cooled down.

Returning Set to Service

1. Remove protective cover.
2. Remove exhaust plugs, seal from carburetor and PVC hose and replace air cleaner.
3. Check oil dipstick to make sure crankcase is full.
4. Refill cooling system.
5. Reconnect battery (positive [+] cable first) and check specific gravity.
6. Connect the battery charger (if applicable).
7. Connect engine coolant heater to power supply (if applicable).
8. Remove all loads before starting set.
9. Start set and apply load of at least 50% of nameplate rating.
10. Check all gauges for normal readings. Set is now ready for service.



8. Adjustments

OUTPUT VOLTAGE ADJUSTMENT

Output voltage can be adjusted plus or minus five percent of nominal voltage by the Voltage Adjust rheostat (optional) on the control panel (Figure 3-3). Call your distributor if the required voltage cannot be obtained by this adjustment.

FUEL SYSTEM ADJUSTMENTS

The engine is equipped with a gas mixer to run on natural gas or propane or both.

⚠WARNING *Fuel is highly flammable and may cause severe personal injury and property damage. Do not allow cigarettes, flame, pilot lights, arcing switches or equipment in area or areas sharing ventilation.*

Gaseous and Combination Fuel Systems

An engine equipped for natural gas and propane has a gas mixer that serves both fuels. Each fuel has a separate shutoff solenoid valve and a fuel pressure switch for automatic fuel changeover. (While the engine is running, the gas pressure switch causes the natural gas solenoid valve to close and the propane solenoid valve to open when natural gas pressure is lost, without stopping the engine. When natural gas pressure is restored, the natural gas solenoid valve opens and the propane solenoid valve closes.)

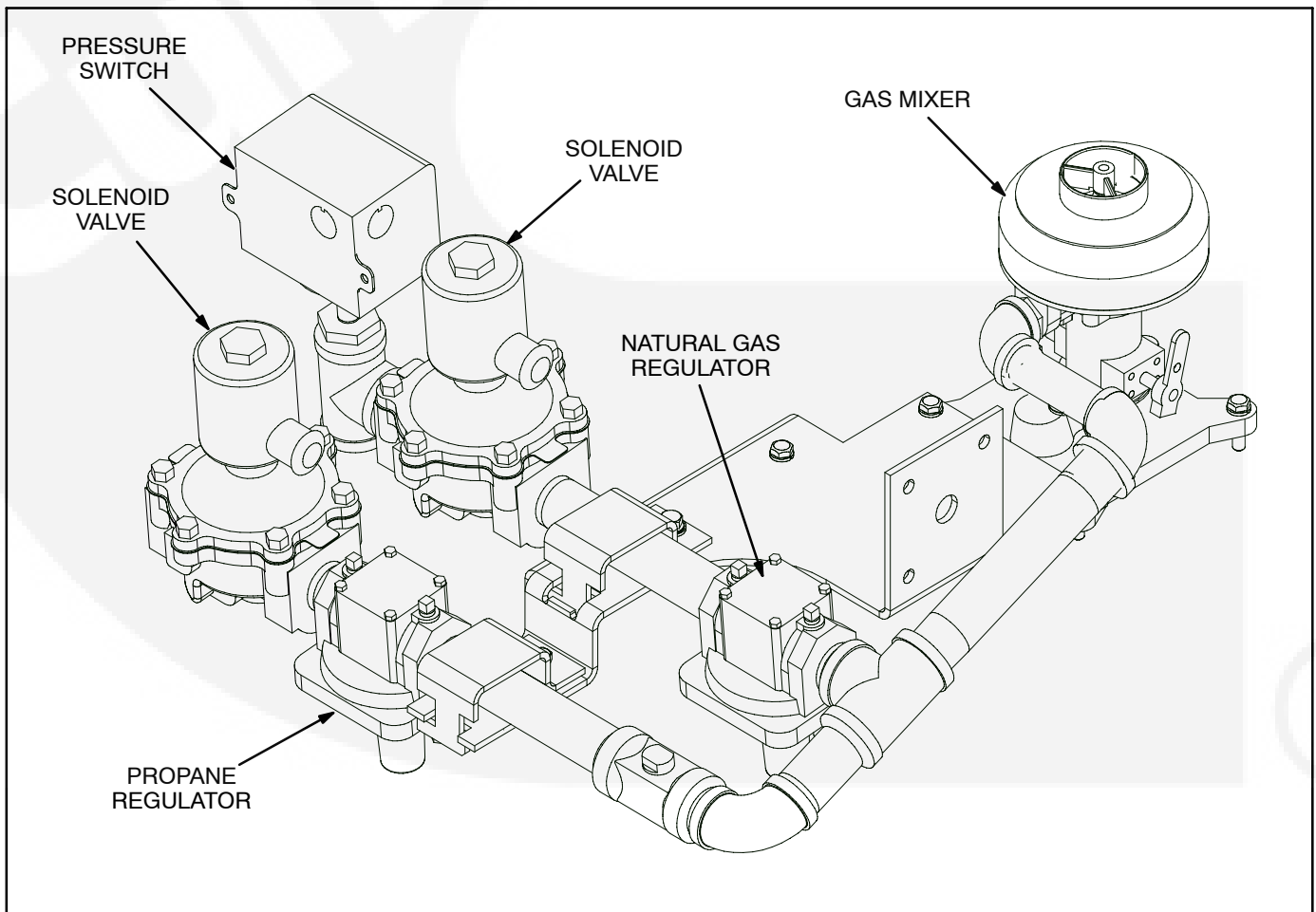

FIGURE 8-1. NATURAL GAS AND LPG VAPOR FUEL SYSTEM (NATURALLY ASPIRATED)

Gaseous Fuel Adjustments: Gas mixers have a power adjust valve and an idle adjustment screw (Figures 8-2 and 8-3). Engines equipped for natural gas and propane (dual fuel) also have a propane flow adjustment valve. If necessary, make the following adjustments.

1. Start the engine and let the set warm up under a partial load (at least 1/4 rated load). If the engine is equipped for natural gas and propane, start with natural gas.

Step 2 is only required if genset instability is present at no-load through 1/4 of rated load.

2. Disconnect all loads, shut down the set, connect a tachometer and disconnect the governor linkage at the carburetor. Start the engine and close and hold the throttle by hand so that the engine does not overspeed. While holding the throttle closed, adjust the throttle idle position screw (the one next to the throttle lever) to obtain an engine speed of 800 RPM. Then turn the idle adjusting screw counterclockwise until engine speed becomes unstable. Turn the screw clockwise just enough to regain stability and reconnect the governor linkage.
3. Next, connect full rated load and turn the power adjust valve to full-rich. Slowly turn the adjust valve towards lean until the engine begins to lose speed and then slowly back towards rich until the engine carries the full load smoothly.
4. If the set is equipped for natural gas and propane, switch to propane by closing the manual shutoff valve in the natural gas supply line.
5. Reconnect full rated load and turn the propane flow adjustment valve clockwise until the engine begins to lose speed and then slowly turn it back counterclockwise until the engine carries full load smoothly.

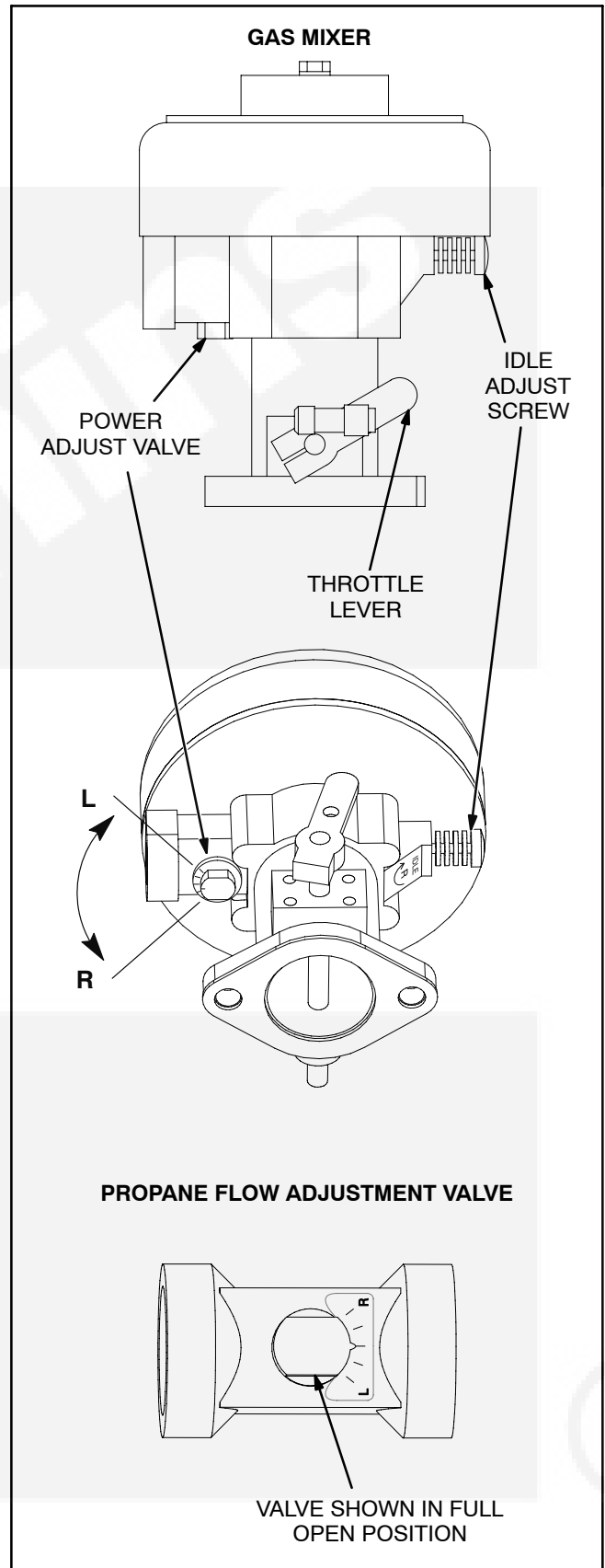

FIGURE 8-2. GASEOUS FUEL ADJUSTMENTS (NATURALLY ASPIRATED)

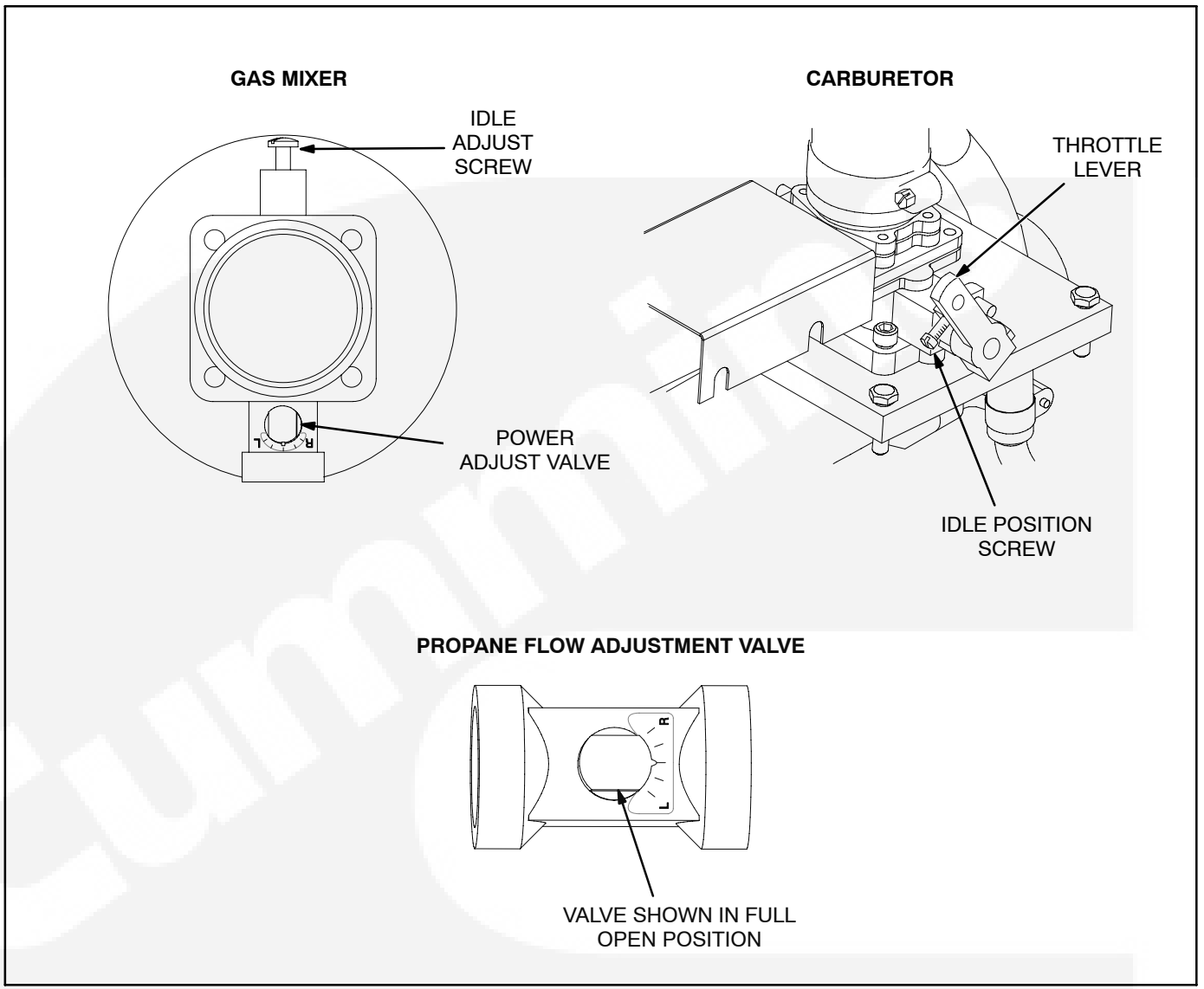

FIGURE 8-3. GASEOUS FUEL ADJUSTMENTS (TURBOCHARGED)



9. Operating Recommendations

BREAK-IN

Drain and replace the crankcase oil after the first 50 hours of operation on new generator sets. Refer to the *Maintenance* section of this manual for the recommended procedures.

NO-LOAD OPERATION

Periods of no load operation should be held to a minimum. If it is necessary to keep the engine running for long periods of time when no electric output is required, best engine performance will be obtained by connecting a “dummy” electrical load (50% or more of set rate). Such a load could consist of heater element or load bank.

EXERCISE PERIOD

Generator sets on continuous standby must be able to go from a cold start to being fully operational in a matter of seconds. This can impose a severe burden on engine parts.

Regular exercising keeps engine parts lubricated, prevents oxidation of electrical contacts and in general helps provide reliable engine starting. Exercise

the generator set at least once a week for a minimum of 30 minutes with load (50% or more of set rate) so the engine reaches normal operating temperatures.

LOW OPERATING TEMPERATURES

Use a coolant heater if a separate source of power is available. The optional heater available from Onan will help provide reliable starting under adverse weather conditions. Be sure the voltage of the separate power source is correct for the heater element rating.

⚠ CAUTION *To avoid damage to heater, be sure the cooling system is full before applying power to the heater.*

POWER RATING FACTORS

The generator set power rating applies to sets used in standby applications. The set will operate at the stated rating for the duration of normal utility power interruptions. The ratings were established for a standard radiator cooled set operating at an altitude of 300 feet (92 m) with an ambient temperature of 81°F (27°C). For a rating relative to other applications, altitudes, cooling systems, or ambient temperatures, contact your authorized distributor.





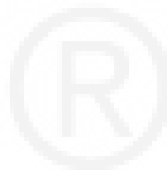

Cummins Power Generation
1400 73rd Avenue N.E.
Minneapolis, MN 55432
1-800-888-6626
763-574-5000 International Use
Fax: 763-528-7229

Cummins is a registered trademark of Cummins Inc.

