

# Operator's Manual

## Detector™ Control Generator Sets

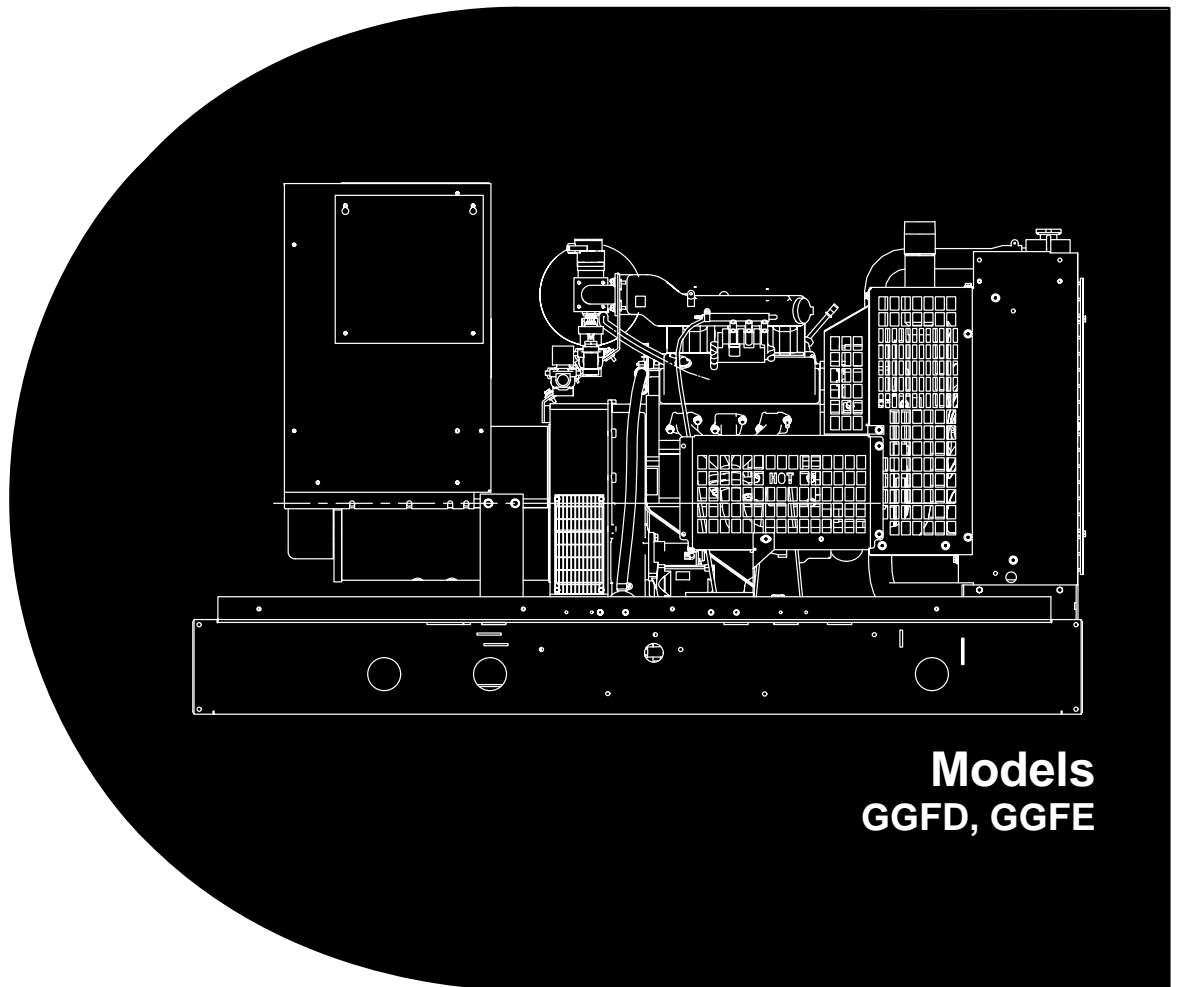

**Models  
GGFD, GGFE**

# IMPORTANT SAFETY INSTRUCTIONS

---

**SAVE THESE INSTRUCTIONS** – This manual contains important instructions that should be followed during installation and maintenance of the generator and batteries.

**Before operating the generator set (genset)**, read the Operator's Manual and become familiar with it and the equipment. **Safe and efficient operation can be achieved only if the equipment is properly operated and maintained.** Many accidents are caused by failure to follow fundamental rules and precautions.

The following symbols, found throughout this manual, alert you to potentially dangerous conditions to the operator, service personnel, or the equipment.

**⚠ DANGER** *This symbol warns of immediate hazards which will result in severe personal injury or death.*

**⚠ WARNING** *This symbol refers to a hazard or unsafe practice which can result in severe personal injury or death.*

**⚠ CAUTION** *This symbol refers to a hazard or unsafe practice which can result in personal injury or product or property damage.*

## FUEL AND FUMES ARE FLAMMABLE

Fire, explosion, and personal injury or death can result from improper practices.

- DO NOT fill fuel tanks while engine is running, unless tanks are outside the engine compartment. Fuel contact with hot engine or exhaust is a potential fire hazard.
- DO NOT permit any flame, cigarette, pilot light, spark, arcing equipment, or other ignition source near the generator set or fuel tank.
- Fuel lines must be adequately secured and free of leaks. Fuel connection at the engine should be made with an approved flexible line. Do not use copper piping on flexible lines as copper will become brittle if continuously vibrated or repeatedly bent.
- Natural gas is lighter than air, and will tend to gather under hoods. Propane is heavier than air, and will

tend to gather in sumps or low areas. NFPA code requires all persons handling propane to be trained and qualified.

- Be sure all fuel supplies have a positive shutoff valve.
- Be sure battery area has been well-ventilated prior to servicing near it. Lead-acid batteries emit a highly explosive hydrogen gas that can be ignited by arcing, sparking, smoking, etc.

## EXHAUST GASES ARE DEADLY

- Provide an adequate exhaust system to properly expel discharged gases away from enclosed or sheltered areas and areas where individuals are likely to congregate. Visually and audibly inspect the exhaust daily for leaks per the maintenance schedule. Make sure that exhaust manifolds are secured and not warped. Do not use exhaust gases to heat a compartment.
- Be sure the unit is well ventilated.
- Engine exhaust and some of its constituents are known to the state of California to cause cancer, birth defects, and other reproductive harm.

## MOVING PARTS CAN CAUSE SEVERE PERSONAL INJURY OR DEATH

- Keep your hands, clothing, and jewelry away from moving parts.
- Before starting work on the generator set, disconnect battery charger from its AC source, then disconnect starting batteries, negative (-) cable first. This will prevent accidental starting.
- Make sure that fasteners on the generator set are secure. Tighten supports and clamps, keep guards in position over fans, drive belts, etc.
- Do not wear loose clothing or jewelry in the vicinity of moving parts, or while working on electrical equipment. Loose clothing and jewelry can become caught in moving parts. Jewelry can short out electrical contacts and cause shock or burning.
- If adjustment must be made while the unit is running, use extreme caution around hot manifolds, moving parts, etc.

## **ELECTRICAL SHOCK CAN CAUSE SEVERE PERSONAL INJURY OR DEATH**

- Remove electric power before removing protective shields or touching electrical equipment. Use rubber insulative mats placed on dry wood platforms over floors that are metal or concrete when around electrical equipment. Do not wear damp clothing (particularly wet shoes) or allow skin surface to be damp when handling electrical equipment.
- Use extreme caution when working on electrical components. High voltages can cause injury or death. **DO NOT** tamper with interlocks.
- Follow all applicable state and local electrical codes. Have all electrical installations performed by a qualified licensed electrician. Tag and lock open switches to avoid accidental closure.
- **DO NOT CONNECT GENERATOR SET DIRECTLY TO ANY BUILDING ELECTRICAL SYSTEM.** Hazardous voltages can flow from the generator set into the utility line. This creates a potential for electrocution or property damage. Connect only through an approved isolation switch or an approved paralleling device.

## **GENERAL SAFETY PRECAUTIONS**

- Coolants under pressure have a higher boiling point than water. **DO NOT** open a radiator or heat exchanger pressure cap while the engine is running. Allow the generator set to cool and bleed the system pressure first.
- Benzene and lead, found in some gasoline, have been identified by some state and federal agencies as causing cancer or reproductive toxicity. When checking, draining or adding gasoline, take care not to ingest, breathe the fumes, or contact gasoline.
- Used engine oils have been identified by some state or federal agencies as causing cancer or reproductive toxicity. When checking or changing engine oil, take care not to ingest, breathe the fumes, or contact used oil.
- Keep multi-class ABC fire extinguishers handy. Class A fires involve ordinary combustible materials such as wood and cloth; Class B fires, combustible and flammable liquid fuels and gaseous fuels; Class C fires, live electrical equipment. (ref. NFPA No. 10).
- Make sure that rags are not left on or near the engine.
- Make sure generator set is mounted in a manner to prevent combustible materials from accumulating under the unit.
- Remove all unnecessary grease and oil from the unit. Accumulated grease and oil can cause overheating and engine damage which present a potential fire hazard.
- Keep the generator set and the surrounding area clean and free from obstructions. Remove any debris from the set and keep the floor clean and dry.
- Do not work on this equipment when mentally or physically fatigued, or after consuming any alcohol or drug that makes the operation of equipment unsafe.
- Substances in exhaust gases have been identified by some state or federal agencies as causing cancer or reproductive toxicity. Take care not to breathe or ingest or come into contact with exhaust gases.
- Do not store any flammable liquids, such as fuel, cleaners, oil, etc., near the generator set. A fire or explosion could result.
- Wear hearing protection when going near an operating generator set.
- To prevent serious burns, avoid contact with hot metal parts such as radiator, turbo charger and exhaust system.

**KEEP THIS MANUAL NEAR THE GENSET FOR EASY REFERENCE**

# Table of Contents

---

SECTION	TITLE	PAGE
	<b>IMPORTANT SAFETY INSTRUCTIONS</b> .....	iii
<b>1</b>	<b>INTRODUCTION</b>	
	General .....	1-1
	How to Obtain Service .....	1-1
<b>2</b>	<b>SPECIFICATIONS</b> .....	2-1
<b>3</b>	<b>OPERATION</b>	
	General .....	3-1
	Prestart Checks .....	3-1
	Control Panel .....	3-1
	Generator AC Voltage Regulator .....	3-5
	Engine Control Module .....	3-5
	Starting .....	3-6
	Stopping .....	3-6
<b>4</b>	<b>TROUBLESHOOTING</b>	
	Safety Considerations .....	4-1
	Resetting the Control .....	4-1
	Line Circuit Breaker (Optional) .....	4-1
	Troubleshooting Charts .....	4-2
<b>5</b>	<b>MAINTENANCE</b>	
	General .....	5-1
	Maintenance Schedule (Standby Power) .....	5-2
	Maintenance Schedule (Prime Power) .....	5-3
	Generator Set Inspection .....	5-4
	Generator Set Maintenance (Battery Disconnected) .....	5-5
	Lubrication System .....	5-6
	Cooling System .....	5-9
	Air Filter .....	5-11
	Serpentine Belt Replacement .....	5-13
	Ignition System .....	5-14
	Batteries .....	5-15
	Out-of-Service Protection .....	5-16

**⚠ WARNING: ⚠**

The engine exhaust from this product contains chemicals known to the State of California to cause cancer, birth defects or other reproductive harm.

SECTION	TITLE	PAGE
<b>6</b>	<b>ADJUSTMENTS</b>	
	Output Voltage Adjustment .....	6-1
	Fuel System Adjustments .....	6-1
<b>7</b>	<b>OPERATING RECOMMENDATIONS</b>	
	Break-In .....	7-1
	No-Load Operation .....	7-1
	Exercise Period .....	7-1
	Low Operating Temperatures .....	7-1
	High Operating Temperatures .....	7-1

# 1. Introduction

---

## GENERAL

This manual covers models produced under the Cummins®/Onan® and Cummins Power Generation brand names.

Each operator should read this manual before operating the set for the first time. A generator set (gen-set) must be operated and maintained properly if you are to expect safe, reliable and quiet operation. The manual includes a troubleshooting guide and a maintenance schedule.

The engine manual is included with the set. Where there is conflicting information, this manual takes precedence over the engine manual.

**⚠ WARNING** *Improper operation and maintenance can lead to severe personal injury or loss of life and property by fire, electrocution, mechanical breakdown or exhaust gas asphyxiation. Read and follow the safety precautions on page iii and carefully observe all instructions and precautions in this manual.*

## HOW TO OBTAIN SERVICE

When the generator set requires servicing, contact your nearest Cummins Power Generation distribu-

tor. Factory-trained Parts and Service representatives are ready to handle all your service needs.

To contact your local Cummins Power Generation distributor in the United States or Canada, call 1-800-888-6626 (this automated service utilizes touch-tone phones only). By selecting Option 1 (press 1), you will be automatically connected to the distributor nearest you.

If you are unable to contact a distributor using the automated service, consult the Yellow Pages. Typically, our distributors are listed under:

GENERATORS-ELECTRIC or  
ELECTRICAL PRODUCTS

For outside North America, call Cummins Power Generation, 1-763-574-5000, 7:30 AM to 4:00 PM, Central Standard Time, Monday through Friday. Or, send a fax to Cummins Power Generation using the fax number 1-763-574-8087.

When contacting your distributor, always supply the complete Model, Specification, and Serial Number as shown on the generator set nameplate.

## **⚠ WARNING**

**INCORRECT SERVICE OR PARTS REPLACEMENT CAN RESULT IN SEVERE PERSONAL INJURY, DEATH, AND/OR EQUIPMENT DAMAGE. SERVICE PERSONNEL MUST BE TRAINED AND EXPERIENCED TO PERFORM ELECTRICAL AND/OR MECHANICAL SERVICE.**

**THIS PAGE LEFT INTENTIONALLY BLANK**

## 2. Specifications

MODEL	GGFD/GGFE
<b>Engine</b> Onan Modified Ford V-6	ESG-642
<b>Generator kW Rating</b>	See Genset Nameplate for rating information.
<b>Fuel or a combination of two fuels</b>	Propane (Liquid or Vapor) Natural Gas
<b>Fuel Flow (Inlet Pressure)</b> <b>Minimum:</b> NG/LPG <b>Maximum:</b> NG/LPG Vapor withdrawal LPG Liquid withdrawal	7.0 inch H <sub>2</sub> O (1.7 kPa)  13.6 inch H <sub>2</sub> O (3.4 kPa) 312 psi (2,153 kPa)
<b>Exhaust</b> Connection Backpressure (Max. Allowed)	3 inch NPT 30 inch H <sub>2</sub> O (7.5 kPa)
<b>Electrical System</b> Starting Voltage Battery Charging Alternator (Max. Rating)	12 Volts DC 37 A
<b>Cooling System</b> Capacity with Standard Radiator	7.0 Gal (26.5 L)
<b>Lubricating System</b> Oil Capacity with Filters Standby Power (Normal Oil Filter) Prime Power (Heavy Duty Oil Filter)	6.0 Qts (5.7 L) 9.7 (9.2 L)
<b>Tune-up Specifications</b> Spark Plug Gap	0.044 (1.1 mm)
<b>Battery</b> Ground Required Battery Voltage Group Number CCA (minimum) Cold Soak @ 0° F (-18° C)	Negative 12 Volts DC 31  660

### FUEL CONSUMPTION (STANDBY/PRIME/60HZ)

MODEL	GGFD	GGFE
<b>Standby</b> cfh (m3/hr) LPG (Vapor or Liquid) Natural Gas	191 (5.41) 488 (13.82)	246 (6.97) 579 (16.4)
<b>Full Load</b> cfh (m3/hr) LPG (Vapor or Liquid) Natural Gas	172 (4.87) 436 (12.35)	225 (6.37) 507 (14.36)



**THIS PAGE LEFT INTENTIONALLY BLANK**

# 3. Operation

---

## GENERAL

This section covers prestart checks, starting and stopping and operating the generator set. Each operator should read through this entire section before attempting to start the set. It is essential that the operator be completely familiar with the set for safe operation. Refer to *Section 7* for operating recommendations.

## PRESTART CHECKS

Before starting, be sure the following checks have been made and the unit is ready for operation. Refer to the *Maintenance* section for the recommended procedures.

### Lubrication

Check the engine oil level. Keep the oil level as close as possible to the dipstick high mark without overfilling.

### Coolant

Check the engine coolant level. The cold coolant level should be about 3/4 inch (18 mm) below the ra-

diator cap lower sealing surface. Do not check while the engine is hot.

**⚠WARNING** *To prevent severe scalding, let engine cool down before removing coolant pressure cap. Turn cap slowly, and do not open it fully until the pressure has been relieved.*

### Fuel

Open all manual shutoff valves in the fuel supply system.

### Exhaust

Check to make sure entire exhaust system is tight, that no combustible materials are near system, and gases are discharged away from building openings.

## CONTROL PANEL

The following describes the function and operation of the Detector Control panel. All instruments and control switches are located on the face of the control panel as illustrated in Figures 3-1 through 3-3. The control panel is separated into a DC panel for monitoring the engine and an AC panel for monitoring the generator.

## EXHAUST GAS IS DEADLY!

***Exhaust gases contain carbon monoxide, an odorless and colorless gas. Carbon monoxide is poisonous and can cause unconsciousness and death. Symptoms of carbon monoxide poisoning can include:***

- ***Dizziness***
- ***Nausea***
- ***Headache***
- ***Weakness and Sleepiness***
- ***Throbbing in Temples***
- ***Muscular Twitching***
- ***Vomiting***
- ***Inability to Think Coherently***

***IF YOU OR ANYONE ELSE EXPERIENCE ANY OF THESE SYMPTOMS, GET OUT INTO THE FRESH AIR IMMEDIATELY. If symptoms persist, seek medical attention. Shut down the unit and do not operate until it has been inspected and repaired.***

***Protection against carbon monoxide inhalation includes proper installation and regular, frequent visual and audible inspections of the complete exhaust system.***

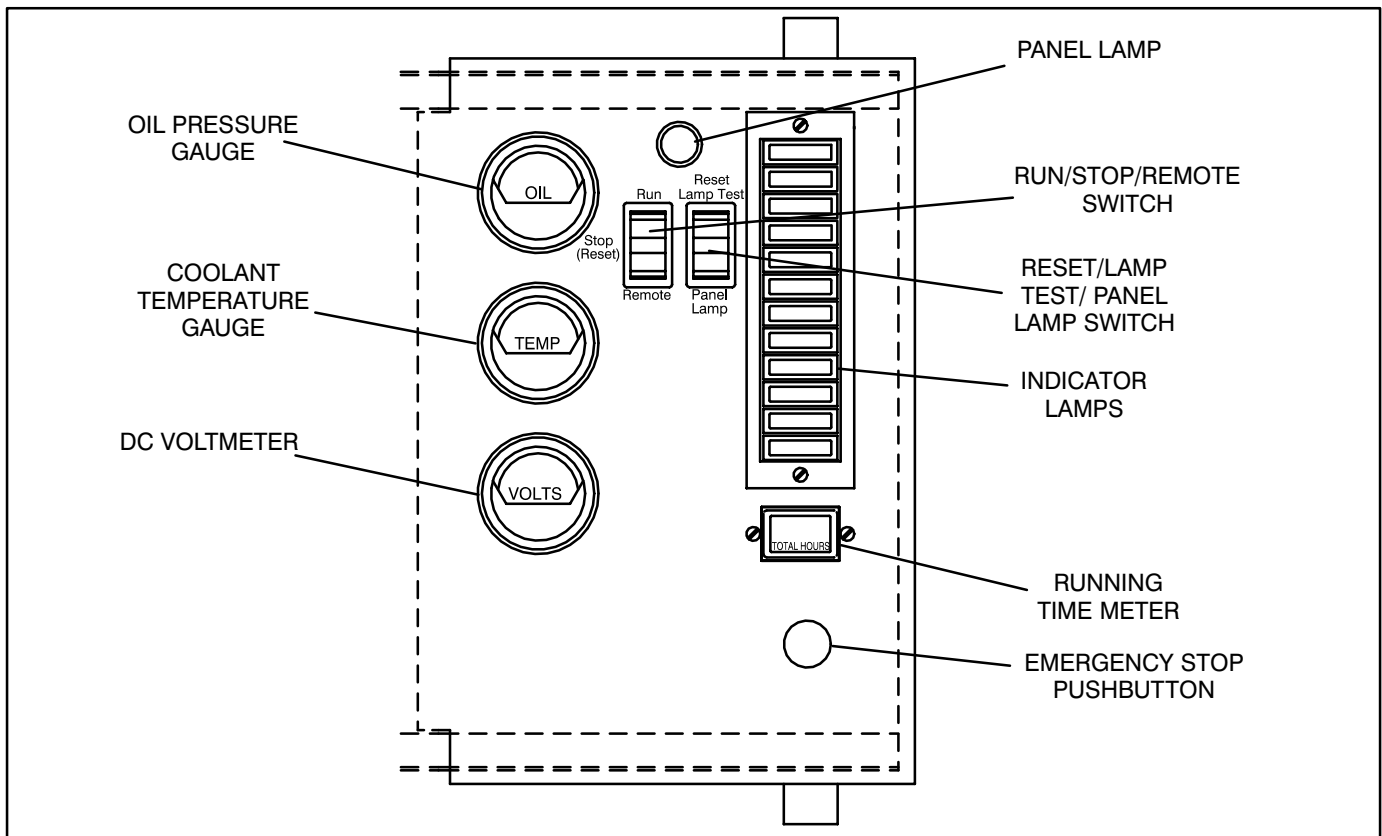

FIGURE 3-1. DC CONTROL PANEL

## DC Panel

**Panel Lamp:** Illuminates control panel.

**Oil Pressure Gauge:** Indicates pressure of lubricating oil in engine (wired to a sensor located on the engine). Normal oil pressure is 40 to 65 psi (276 to 449 kPa) at normal operating temperature.

**Coolant Temperature Gauge:** Indicates temperature of circulating coolant in engine (wired to a sensor located on engine). Engine coolant temperature is typically between 190° to 195° F (88° to 91° C).

**DC Voltmeter:** Indicates the battery charging system voltage. Normal charging voltage is 12 to 14 volts.

**Run/Stop/Remote Switch:** Starts and stops the set locally, or from a remote location wired to the control engine monitor board.

**Running Time Meter:** Registers the total number of hours the unit has run. Use it to keep a record of periodic servicing. Time is cumulative; meter cannot be reset.

**Reset/Lamp Test/Panel Lamp Switch:** Resets the fault circuit only when the Run/Stop/Remote switch is in the Stop (Reset) position. Tests fault lamps and turns on the control panel lamp.

**Emergency Stop Button (Optional):** Push-in switch for emergency shutdown of the engine. To reset, pull switch out and move Run/Stop/Remote switch to Stop position. Then push test switch to Reset/Lamp Test position.

**Indicator Lamps:** The control panel has twelve indicator lamps which are described as follows:

- RUN (green) lamp comes on when starter circuit opens after set starting.
- PRE LO OIL PRES (yellow) indicates engine oil pressure is marginally low.
- PRE HI ENG TEMP (yellow) indicates engine temperature is marginally high.
- LO OIL PRES (red) indicates engine has shut down because of critically low oil pressure.
- HI ENG TEMP (red) indicates engine has shut down because of critically high engine temperature.
- OVERSPEED (red) indicates engine has shut down because of excessive speed.
- OVERCRANK (red) indicates engine has failed to start during the cranking period.
- FAULT 1 (red) lamp indicates an undedicated fault. May be field programmed as a shutdown or non-shutdown, and as a timed or non-timed fault. (Normally set for timed shutdown).
- FAULT 2 (red) lamp indicates same features as Fault 1 (normally set for non-timed shutdown).
- CHECK ENG (red) (optional) lamp indicates air fuel control has sensed an out-of-specification condition. (Replaces Fault 1 or Fault 2 lamp location.)
- LOW ENG TEMP (yellow) lamp lights if engine temperature is marginally low for starting. It may indicate an inoperative coolant heater.
- LO FUEL (yellow) (optional) indicates fuel supply pressure is marginally low (3 inches [76.2 mm] WC or less).
- SWITCH OFF (flashing red) indicates generator set is not in automatic start mode.

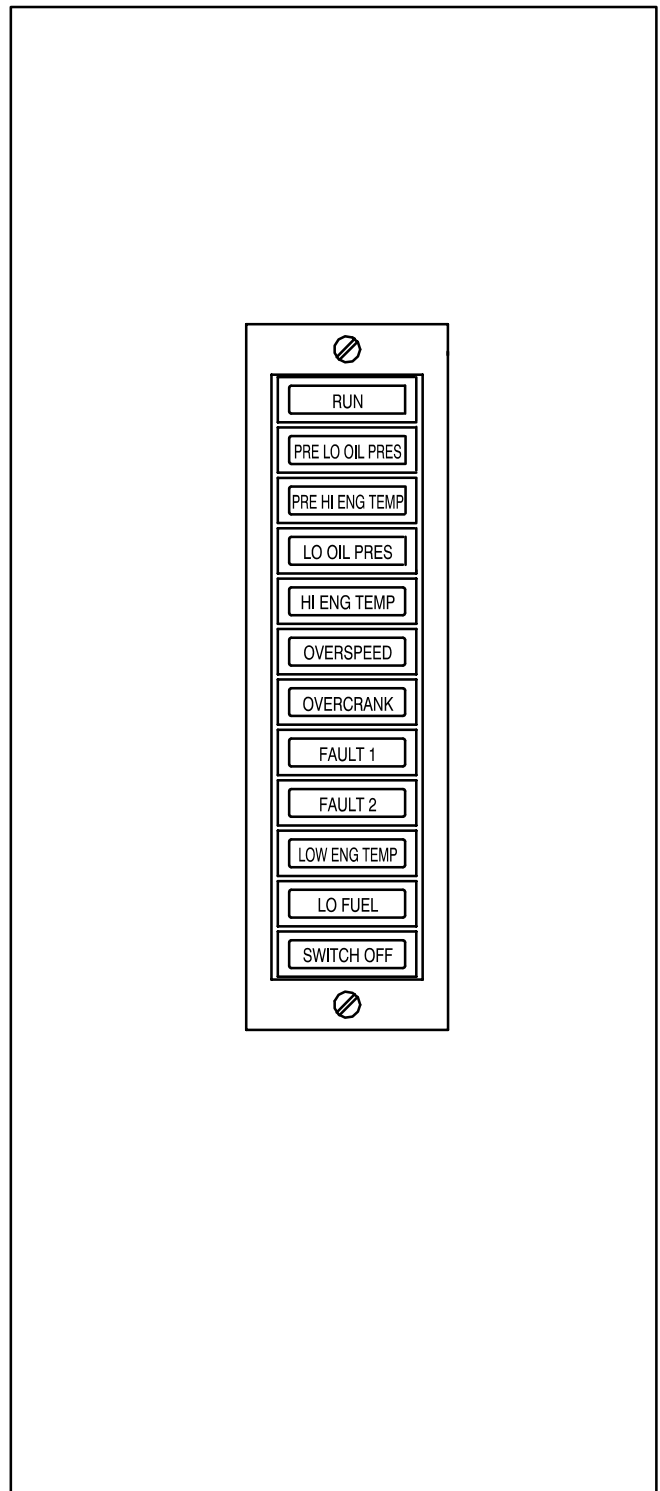

**FIGURE 3-2. INDICATOR LAMPS**

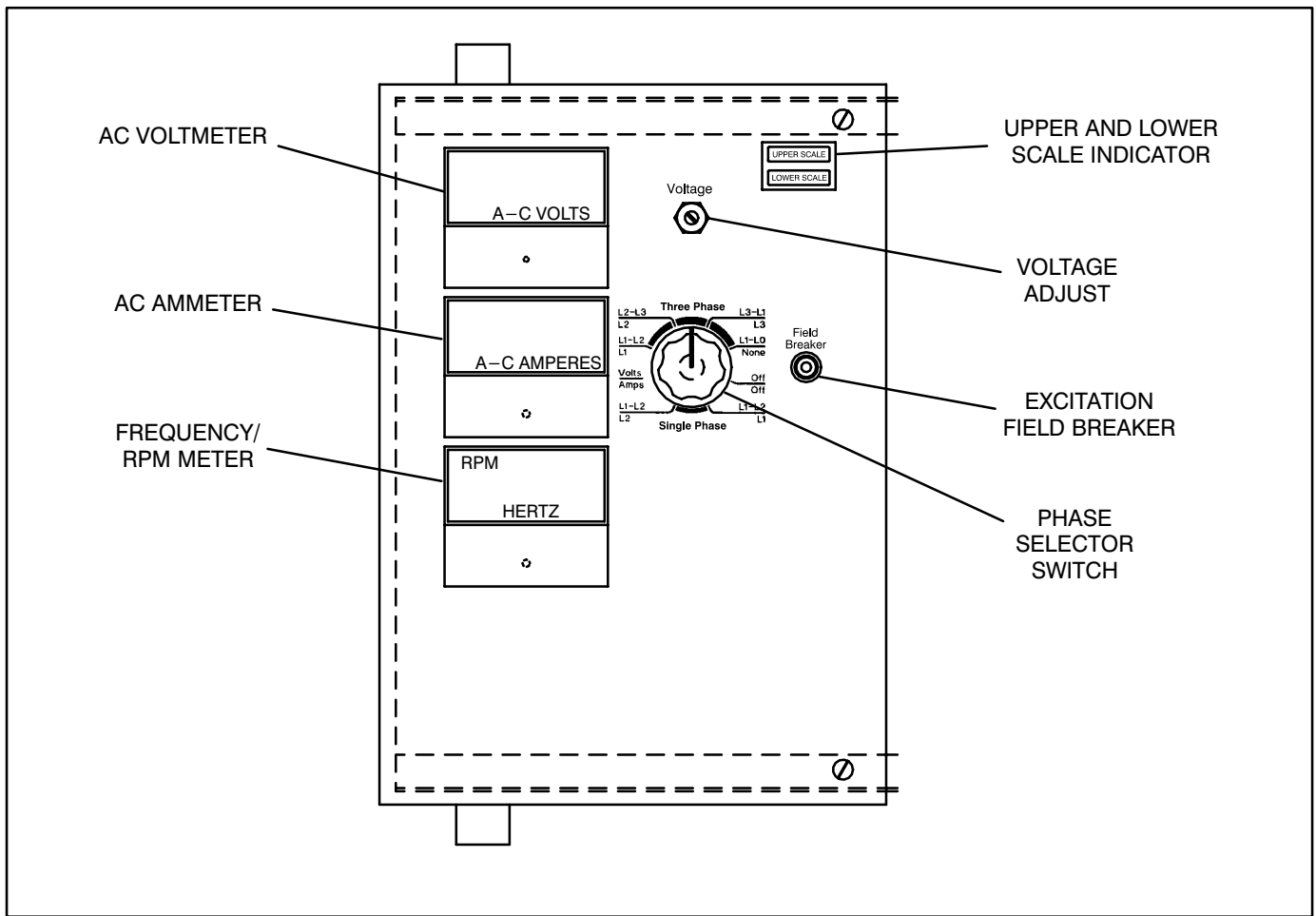

FIGURE 3-3. AC CONTROL PANEL

### AC Panel

**AC Voltmeter:** Dual range instrument indicating AC voltage. Measurement range in use shown on indicator lamp.

**AC Ammeter:** Dual range instrument indicates AC generator line current.

**Frequency/RPM Meter:** Indicates generator output frequency in hertz and engine speed in revolutions-per-minute (RPM).

**Voltage Adjusting Rheostat:** Provides approximately plus or minus five percent adjustment of the rated output voltage.

**Upper and Lower Scale Indicator Lamps:** Indicates which scale to use on the AC voltmeter and ammeter.

**Phase Selector Switch:** Selects phases of generator output to be measured by AC voltmeter and ammeter.

**Field Breaker:** Provides generator exciter and regulator protection from overheating in the event of certain failure modes of generator, exciter and voltage regulator.

## GENERATOR AC VOLTAGE REGULATOR

The solid-state regulator controls AC output voltage from the generator at a predetermined level regardless of load. Refer to the genset *Specification Sheet* for the voltage regulation and random voltage variation specifications.

## ENGINE CONTROL MODULE

Electronic and relay components of the engine monitoring circuit are on a circuit board assembly. Sensor inputs are connected by the wiring harness to plug connectors on the board. The control module provides the following functions of unit protection.

- **Overcrank** – The standard cycle cranking feature allows three 15-second cranking cycles with two 15-second rest periods. If engine fails to start, the module lights a fault lamp and opens the cranking circuit.

The overcrank option limits engine cranking to 75 seconds. If engine fails to start, the module lights a fault lamp and opens the cranking circuit.

- **Overspeed** – Shuts down the engine immediately if overspeed occurs and lights a fault lamp.

Speed sensing is part of the engine ignition system and is not adjustable. 50 and 60 hertz units are both set at 2250 ±50 r/min.

- **Low Oil Pressure** – Shuts down the engine immediately and lights a fault lamp if oil pressure drops below 25 psi (172.4 kPa). The fault is time-delayed about 10 seconds following starter disconnect and inhibited during cranking. The delay allows oil pressure to rise to normal before the electronic control module monitors this system.

A pre-low oil pressure sensor and lamp provides an alarm that oil pressure is marginally low or less than 30 psi (206.8 kPa). The cause should be found and corrected as soon as possible.

- **High Engine Temperature** – shuts down the engine immediately if coolant temperature rises above 230° F (110° C) and lights a fault lamp. The fault is time-delayed about 10 seconds following starter disconnect and inhibited during cranking. This delay allows coolant in a hot engine time to circulate and return the water jacket to normal before the electronic control module monitors this system.

A pre-high engine temperature sensor and lamp provides an alarm that engine temperature is marginally high, 220° F (104° C). The cause should be found and corrected as soon as possible.

**CAUTION** *Loss of coolant can prevent sensor operation and allow the engine to overheat causing severe damage to the engine. Maintain coolant level for proper operation of the high engine temperature shutdown system.*

- **Low Coolant Level Alarm/Shutdown** (Optional) – An electronic switch that provides engine alarm or shutdown if coolant level falls too low. It also turns on the fault lamp.
- **Low Fuel Pressure Alarm** (Optional) – A switch that provides engine alarm if primary fuel pressure falls below 3 inches (76.2 mm) water column pressure. It also turns on a fault lamp.
- **Check Engine Alarm** (Included with low emission option) – An electronic switch within the air/fuel control that provides an alarm when the control senses an out-of-specification condition. It also turns on the fault lamp.

## STARTING

The following sections cover the three systems used to start the generator set.

Before starting the generator set, make sure that exhaust and fuel fittings are tight and properly positioned and that proper maintenance has been performed. See *Prestart Checks* in this section.

### Starting at Control Panel

Move the Run-Stop-Remote switch on the DC panel to the RUN position. This will activate the engine control system and the starting system. The starter will begin cranking and after a few seconds the engine should start. The starter will disconnect when the engine reaches a speed of approximately 1000 RPM.

If the engine does not start, the starter will disengage after a specified period of time and the control will indicate an overcrank fault. Generator sets with the optional overcrank control will crank continuously for up to 75 seconds before disengaging the starter. Generator sets with the standard cycle cranking feature will crank for 15 seconds in each cycle until 3 cycles have been completed. To clear an overcrank fault, place the Run-Stop-Remote switch in the STOP position and momentarily press the Reset switch. Wait two minutes for the starter motor to cool and then repeat the starting procedure. If the engine does not run after a second attempt at starting, refer to the *Troubleshooting* section.

### Starting From Remote Location

Move the Run/Stop/Remote switch on the generator set DC panel to the REMOTE position. This allows the generator set to be started from a remote switch. Closing the remote switch initiates the starting sequence described in the previous section.

### Automatic Starting

Place the Run/Stop/Remote switch on the generator set DC panel in the REMOTE position if an automatic transfer switch is used. This allows the transfer switch to start the generator set if a power outage occurs and stop it when the power returns.

### Cold Starting With Loads

In accordance with NFPA 110, Cummins Power Generation recommends installing standby gener-

ator sets (life safety systems) equipped with coolant heaters in locations where the minimum ambient temperature is above 40°F (4°C). NFPA also requires that the engine coolant be maintained at a minimum of 90°F (32°C) and for most applications, accept the emergency load in 10 seconds or less. Although most generator sets will start in temperatures below 40°F (4°C) when equipped with coolant heaters, it might take some running time to warm the engine up before a load can be applied when ambient temperatures are below 40°F (4°C).

The Low Engine Temperature (LET) lamp on the Detector™ control is provided to meet the requirements of NFPA 110. The LET sensor signals an alarm when the engine coolant temperature falls below 70°F (21°C). In applications where the ambient temperature falls below 40°F (4°C), the LET may be lit even though the coolant heaters are connected and operable. Under these conditions, although the generator set may start, it may not be able to accept load within 10 seconds. When this condition occurs, check the coolant heaters for proper operation. If the coolant heaters are operating properly, other precautions might be necessary to warm the engine before applying a load.

## STOPPING

### Before Stopping

Run the generator set at no load for three to five minutes before stopping. This allows the lubricating oil and engine coolant to carry heat away from the combustion chamber and bearings.

### To Stop

If the set was started at the set control panel or at a remote control panel, move the Run/Stop/Remote switch or remote starting switch to the STOP position. If the set was started by an automatic transfer switch, the transfer switch will send a remote (timed delay) stop signal after the normal power source returns.

### Emergency Stop

An optional emergency stop button is located on the right side of control panel (Figure 3-1). Push button in for emergency stop. To reset, pull switch out and move Run/Stop/Remote switch to Stop position. Then push test switch to Reset/Lamp Test position.

# 4. Troubleshooting

---

The generator set has sensors that continuously monitor the engine for abnormal conditions, such as low oil pressure or high coolant temperature. If these conditions occur, the engine monitor activates a fault lamp, and may also stop the engine (depending on the condition). If the generator set is stopped for this reason, the operator may be able to restart the set after making adjustments or corrections. This section describes the fault condition system, and suggests troubleshooting procedures.

The control has a single green light to indicate RUN, four amber lights and seven red fault lights. The control also has a terminal connection for an audible alarm, which sounds when a fault occurs.

## SAFETY CONSIDERATIONS

**⚠ WARNING** *Contacting high voltage components can cause electrocution, resulting in severe personal injury or death. Keep control and output box covers in place during troubleshooting.*

High voltages are present inside the control box and generator output box when the set is running. Do not open the control box or generator output box while the set is running.

**⚠ WARNING** *Ignition of explosive battery gases can cause severe personal injury or death. Arcing at battery terminals, light switch or other equipment, flame, pilot lights and sparks can ignite battery gas. Do not smoke, or switch trouble light ON or OFF near battery. Discharge static electricity from body before touching batteries by first touching a grounded metal surface.*

*Ventilate battery area before working on or near battery—Wear goggles—Stop genset and disconnect charger before disconnecting battery cables—Disconnect negative (–) cable first and reconnect last.*

**⚠ CAUTION** *Disconnect battery charger from AC source before disconnecting battery cables. Otherwise, disconnecting cables can result in voltage spikes damaging to DC control circuits of the set.*

**⚠ WARNING** *Accidental starting of the generator set can cause severe personal injury or death. Prevent accidental starting by disconnecting the negative (–) cable from the battery terminal.*

When troubleshooting a set that is shut down, make certain the generator set cannot be accidentally restarted as follows:

1. Move the Run/Stop/Remote switch on the control panel to the Stop position.
2. Turn off or remove AC power from the battery charger.
3. Remove the negative (–) battery cable from the generator set starting battery.

When a fault lamp turns on during operation, follow the procedures listed in Table 4-1 to locate and correct the problem. For any symptom not listed, contact an authorized service center for assistance.

## RESETTING THE CONTROL

The external alarm and fault lamp may be deactivated by moving the Run/Stop/Remote switch to the Stop position and pressing the Reset/Lamp Test/Panel Lamp switch. Locate the problem and correct it before restarting the set. While pressing the Reset/Lamp Test/Panel Lamp switch, make certain that all lamps light.

## LINE CIRCUIT BREAKER (OPTIONAL)

The optional line circuit breaker mounts on the generator output box. If the load exceeds the generator current rating, the line circuit breaker will open, preventing the generator from being overloaded. If the circuit breaker trips, locate the source of the overload and correct as necessary. Manually reset the breaker to reconnect the load to the generator.



**TABLE 4-1. TROUBLESHOOTING**

<p><b>⚠ WARNING</b> <i>Hazards present in troubleshooting can cause equipment damage, severe personal injury or death. Only trained and experienced service personnel with knowledge of fuels, electricity, and machinery hazards should perform service procedures. Read Safety Precautions page and observe all instructions and precautions in this manual.</i></p>	
<b>SYMPTOM</b>	<b>CORRECTIVE ACTION</b>
1. Green RUN lamp lights following engine startup.	1. Indicates all engine systems are normal. No corrective action required.
2. PRE HI ENGINE TEMP lamp lights. Engine continues to operate. (Engine can be programmed to shut down.)	<p>2. Indicates engine has begun to overheat and engine temperature has risen to approximately 220°F (104° C) or coolant level is low on optionally wired sets. If generator is powering non-critical and critical loads and cannot be shut down, use the following:</p> <ul style="list-style-type: none"> <li>a. Reduce load if possible by turning off non-critical loads.</li> <li>b. Check air inlets and outlets and remove any obstructions to airflow.</li> </ul> <p><b>If engine can be stopped, follow procedure in step 3.</b></p>
3. HI ENG TEMP lamp lights. Engine shuts down.	<p>3. Indicates engine has overheated (engine temperature has risen above 230°F/110°C) or coolant level is low. Allow engine to cool down completely before proceeding with the following checks:</p> <ul style="list-style-type: none"> <li>a. Check coolant level and replenish if low. Look for possible coolant leakage points and repair if necessary.</li> <li>b. Check for obstructions to cooling airflow and correct as necessary.</li> <li>c. Check for a slipping fan belt and tighten if loose.</li> <li>d. Reset control and restart after locating and correcting problem. Contact an authorized service center if none of the above.</li> </ul>
4. PRE LO OIL PRES lamp lights. Engine continues to operate. (Engine can be programmed to shut down.)	4. Indicates engine oil pressure has dropped to 30 psi (207 kPa). If generator is powering critical loads and cannot be shut down, wait until next shutdown period and then follow step 5 procedure. If engine can be stopped, follow procedures in step 5.
5. LO OIL PRES lamp lights. Engine shuts down. NOTE: See also step 6.	5. Indicates engine oil pressure has dropped to 25 psi (172 kPa). Check oil level, lines and filters. If oil system is OK but oil level is low, replenish. Reset control and restart. Contact an authorized service center if oil pressure is not in the range of 40 to 65 psi (276 to 449 kPa).

**TABLE 4-1. TROUBLESHOOTING (CONT.)**

**⚠ WARNING** *Hazards present in troubleshooting can cause equipment damage, severe personal injury or death. Only trained and experienced service personnel with knowledge of fuels, electricity, and machinery hazards should perform service procedures. Read Safety Precautions page and observe all instructions and precautions in this manual.*

SYMPTOM	CORRECTIVE ACTION
<p>6. OVERCRANK lamp lights and engine stops cranking.</p> <p>or</p> <p>Engine runs, shuts down, and LO OIL PRES lamp lights..</p>	<p>6. Indicates possible fuel system problem.</p> <ul style="list-style-type: none"> <li>a. Open any closed fuel shutoff valve.</li> <li>b. Check for dirty or plugged air filter and replace if necessary (see <i>Maintenance</i> section).</li> <li>c. Gaseous fuel delivery to the set is inadequate. Contact an authorized service center for service.</li> <li>d. Reset the control and restart after correcting the problem. Contact an authorized service center for service if none of the above.</li> </ul>
<p>7. OVERSPEED lamp lights and the engine shuts down.</p>	<p>7. Indicates engine has exceeded normal operating speed. Contact an authorized service center for service.</p>
<p>8. SWITCH OFF lamp flashes.</p>	<p>8. Indicates Run/Stop/Remote switch is in the Stop position which will prevent automatic starting if an automatic transfer switch is used. Move the Run/Stop/Remote switch to the Remote position for automatic starting.</p>
<p>9. LO FUEL lamp lights. Engine continues to run or is in standby mode.</p>	<p>9. Indicates fuel supply pressure is low (3 inches [76 mm] WC or less). Check for partially closed shutoff valve, empty propane supply tank. For natural gas fueled sets, check with the gas utility.</p>
<p>10. LO ENG TEMP lamp lights. Set is in standby mode but is not operating.</p> <p>(Lamp lights when engine coolant temperature is 70° F (28° C) or lower. Since the lamp goes out after the engine warms up, there should be no cause for alarm even during initial generator set operation.)</p>	<p>10. Indicates engine coolant heater is not operating, not circulating coolant or ambient temperature too cold for heater to keep up with demand. Check for the following conditions:</p> <ul style="list-style-type: none"> <li>a. Coolant heater not connected to power supply. Check for blown fuse or disconnected heater cord and correct as required.</li> <li>b. Check for low coolant level and replenish if required. Look for possible coolant leakage points and repair as required.</li> <li>c. Contact an authorized service center if none of the above.</li> </ul>
<p>11. The FAULT 1 or FAULT 2 fault lamp lights. Engine shuts down immediately, engine runs for several seconds and then shuts down, or engine continues to run.</p>	<p>11. The standard undesignated fault functions are programmed to shut down the set when a fault is sensed. Fault 1 is time delayed while Fault 2 is immediate. The nature of the fault is an optional selection that is determined when the set installation is designed. The undesignated fault functions may also be programmed for non-shutdown or non-time delay.</p>

**TABLE 4-1. TROUBLESHOOTING (CONT.)**

<p><b>⚠ WARNING</b> <i>Hazards present in troubleshooting can cause equipment damage, severe personal injury or death. Only trained and experienced service personnel with knowledge of fuels, electricity, and machinery hazards should perform service procedures. Read Safety Precautions page and observe all instructions and precautions in this manual.</i></p>	
<b>SYMPTOM</b>	<b>CORRECTIVE ACTION</b>
11. CHECK ENG fault lamp lights. Engine continues to run or is in standby mode.	11. Indicates the optional low emission air/fuel control has sensed an out-of-specification condition. Contact an authorized service center for service.
12. Fault lamp lights but no fault exists. Engine gauges show oil pressure, engine temperature, and frequency (speed) are within normal limits.	12. The monitor board or a sensor may be at fault. Contact an authorized service center for service.
13. Engine starts from generator control panel but will not start automatically or from a remote panel. (Note: The Run/Stop/Remote switch must be in the Remote position for automatic or remote starting).	13. Remote circuit breaker is tripped. Reset breaker and restart. Contact an authorized service center if breaker trips after resetting.
14. Engine will not crank.	14. Indicates possible fault with control or starting system. Check for the following conditions: <ul style="list-style-type: none"> <li>a. Fault lamp on. Correct fault and reset control.</li> <li>b. Poor battery cable connections. Clean the battery cable terminals and tighten all connections.</li> <li>c. Discharged or defective battery. Recharge or replace the battery.</li> <li>d. Emergency stop button (if equipped) pushed in. To reset, pull switch out and move Run/Stop/Remote switch to Stop position. Then push test switch to Reset/ Lamp position.</li> <li>e. Contact an authorized service center if none of the above.</li> </ul>
15. No AC output voltage.	15. Field breaker is tripped. Reset breaker. Contact an authorized service center if voltage buildup causes breaker to trip.
16. RUN or fault lamp(s) does not light when Lamp Test switch is engaged.	16. Contact an authorized service center for assistance.
17. Green RUN lamp does not light following engine startup.	17. Indicates possible Start/Disconnect relay failure. Contact an authorized service center for assistance.

# 5. Maintenance

---

## GENERAL

Establish and adhere to a definite schedule for maintenance and service based on the application and severity of the environment. The recommended service intervals for a generator set on STANDBY power service is covered in Table 5-1 and for PRIME power service Table 5-2. If the set will be subjected to extreme operating conditions, the service intervals should be reduced accordingly. Some of the factors that can affect the maintenance schedule are the following:

- Extremes in ambient temperature
- Exposure to weather

- Exposure to salt water
- Exposure to dust, sand or other airborne contaminants.

Consult with your local Cummins Power Generation distributor if the generator set will be subjected to any extreme operating conditions and determine a suitable schedule of maintenance. Use the running time meter to keep an accurate log of all service performed for warranty support. Perform all service at the time period indicated or after the number of operating hours indicated, whichever comes first. Use Table 5-1 (Standby) or Table 5-2 (Prime) to determine the maintenance required and then refer to the sections that follow for the correct service procedures.

**TABLE 5-1. PERIODIC MAINTENANCE SCHEDULE FOR  
STANDBY POWER GENSETS**

MAINTENANCE ITEMS	SERVICE TIME				
	Daily or after 8 Hours	Monthly or after 100 Hours	After 100 Hours	6 Months or after 250 Hours	Yearly or after 500 Hours
General set inspection	X <sup>1</sup>				
Check engine oil level	X				
Check coolant level	X				
Check coolant heater(s)	X				
Check air cleaner (normal duty filter)		X <sup>2,3</sup>			
Check all hardware (fittings, clamps, fasteners, etc.)		X			
Check battery electrolyte level		X			
Check generator air outlet		X			
Change engine oil and filter (normal duty filter)			X <sup>2,8</sup>		
Check radiator hoses for wear and cracks				X <sup>4</sup>	
Check drive belt				X <sup>5</sup>	
Check anti-freeze concentration				X	
Check AC generator and controls				X	
Clean cooling systems					X
Inspect or replace spark plugs					X <sup>6</sup>
Inspect or replace oxygen sensor					X <sup>6,7</sup>
Test catalytic converter restriction					X <sup>7</sup>

X<sup>1</sup> - Check for oil, fuel, cooling and exhaust system leaks. Check exhaust system audibly and visually with set running and repair any leaks immediately.

X<sup>2</sup> - Perform more often in extremely dusty conditions.

X<sup>3</sup> - Replace element after 500 hours.

X<sup>4</sup> - Replace if hard or brittle.

X<sup>5</sup> - Visually check belt for evidence of wear or slippage. Replace if hard or brittle.

X<sup>6</sup> - Replace every 1,000 hours.

X<sup>7</sup> - Must be performed by a qualified mechanic. Contact your authorized service center.

X<sup>8</sup> - Perform at least once a year.

**TABLE 5-2. PERIODIC MAINTENANCE SCHEDULE FOR  
PRIME POWER GENSETS**

MAINTENANCE ITEMS	SERVICE TIME				
	24 Hours	100 Hours	250 Hours	500 Hours	1000 Hours
General set inspection	X <sup>1</sup>				
Check engine oil level	X				
Check coolant level	X				
Check coolant heater(s)	X				
Check air cleaner (heavy duty filter)		X <sup>2,3</sup>			
Check all hardware (fittings, clamps, fasteners, etc.)			X		
Check battery electrolyte level			X		
Check anti-freeze concentration			X		
Check generator air outlet			X		
Change engine oil and filter (heavy duty filter)				X <sup>2</sup>	
Check radiator hoses for wear and cracks				X <sup>4</sup>	
Check drive belt				X <sup>5</sup>	
Check AC generator and controls				X	
Clean cooling systems				X	
Inspect or replace spark plugs					X <sup>6</sup>
Inspect or replace oxygen sensor					X <sup>6,7</sup>
Test catalytic converter restriction					X <sup>7</sup>

X<sup>1</sup> - Check for oil, fuel, cooling and exhaust system leaks. Check exhaust system audibly and visually with set running and repair any leaks immediately.

X<sup>2</sup> - Perform more often in extremely dusty conditions.

X<sup>3</sup> - Replace element every 2000 hours.

X<sup>4</sup> - Replace if hard or brittle.

X<sup>5</sup> - Visually check belt for evidence of wear or slippage. Replace if hard or brittle.

X<sup>6</sup> - Replace every 2,000 hours.

X<sup>7</sup> - Must be performed by a qualified mechanic. Contact your authorized service center.

## GENERATOR SET INSPECTION

During operation, be alert for mechanical problems that could create unsafe or hazardous conditions. The following sections cover several areas that should be frequently inspected for continued safe operation.

### Exhaust System

With the generator set operating, inspect the entire exhaust system visually and audibly, including the exhaust manifold, catalytic converter, muffler, and exhaust pipe. Check for leaks at all connections, welds, gaskets, and joints and also make sure that exhaust pipes are not heating surrounding areas excessively. If any leaks are detected, shut down the generator set and have leaks corrected immediately.

**⚠WARNING** *Inhalation of exhaust gases can result in severe personal injury or death. Be sure deadly exhaust gas is piped outside and away from any windows, doors, vents or other inlets to building and not allowed to accumulate in inhabitable areas.*

### Fuel System

With the generator set operating, inspect the fuel supply lines, filters, and fittings for leaks. Check any flexible sections for cuts, cracks and abrasions and make sure they are not rubbing against anything that could cause breakage. If any leaks are detected, shut off fuel supply valves, shut down generator set and have them corrected immediately.

**⚠WARNING** *Ignition of fuel can cause severe personal injury or death by fire or explosion. Do not permit any flame, cigarette, arcing switch or equipment, pilot light, or other igniter near the fuel system or in areas sharing ventilation.*

### AC Electric System

Check the following while the generator set is operating.

**Frequency Meter:** The generator frequency should be stable and the reading should be the same as the nameplate rating.

**AC Voltmeter:** Turn the phase selector switch to each line-to-line phase selection shown on the volts scale (L1-L2, L2-L3, and L3-L1). Read the AC voltmeter using the upper or lower scale as indicated by the scale indicator light. At no load, the line-to-line voltage(s) should be the same as the set nameplate rating.

**AC Ammeter:** Turn the phase selector switch to each phase selection shown on the amps scale (L1, L2 and L3). Read the ammeter using the upper or lower scale as indicated by the scale indicator light. At no load, the current readings should be zero. With a load applied, each line current should be about the same.

**Fault Lamps:** Push the Reset/Lamp switch on the control panel. All indicator lamps should light. Confirm that all of the bulbs are on, then release the switch. Have any bulbs that are burned out replaced.

### DC Electrical System

Check the terminals on the batteries for clean and tight connections. Loose or corroded connections create resistance which can hinder starting. Refer to **BATTERIES** later in this section for cleaning and safety precautions.

### Engine

Monitor fluid levels and oil pressure and coolant temperatures frequently. Most engine problems give an early warning. Look and listen for changes in engine performance, sound, or appearance that can indicate service or repair is needed. Some engine changes to look for are as follows:

- Misfire
- Vibration
- Unusual noises
- Sudden changes in engine operating temperatures or pressures
- Excessive exhaust smoke
- Loss of power
- An increase in oil consumption
- An increase in fuel consumption
- Fuel, oil, or coolant leaks.

## GENERATOR SET MAINTENANCE (Battery Disconnected)

**⚠ WARNING** *Ignition of explosive battery gases can cause severe personal injury or death. Arcing at battery terminals, light switch or other equipment, flame, pilot lights and sparks can ignite battery gas. Do not smoke, or switch trouble light ON or OFF near battery. Discharge static electricity from body before touching batteries by first touching a grounded metal surface.*

*Ventilate battery area before working on or near battery—Wear goggles—Stop genset and disconnect charger before disconnecting battery cables—Disconnect negative (–) cable first and reconnect last.*

**⚠ CAUTION** *Disconnect battery charger from AC source before disconnecting battery cables. Otherwise, disconnecting cables can result in voltage spikes damaging to DC control circuits of the set.*

**⚠ WARNING** *Accidental starting of the generator set can cause severe personal injury or death. Prevent accidental starting by disconnecting the negative (–) cable from the battery terminal before beginning maintenance procedures.*

When performing the following maintenance procedures, make certain the generator set cannot be accidentally restarted as follows:

1. Place the run switch on the control panel to the OFF or STOP position.
2. Turn off or remove AC power from the battery charger.
3. Remove the negative (–) battery cable from the generator set starting battery.

### **Mechanical Inspection**

With the generator set stopped, check for loose belts and fittings, leaking gaskets and hoses, or any signs of mechanical damage. If any problems are found, have them corrected immediately.



## LUBRICATION SYSTEM

Before the initial start, check dipstick to be sure crankcase is filled with oil. See *Specifications* section for lubricating oil capacity.

**Gensets are shipped with oil added. Be sure to check oil level before initial start.**

### Oil Recommendations

Refer to Figure 5-1 for the recommended oil viscosity grades at various ambient temperatures. Oils must conform to the American Petroleum Institute (API) classification SJ or SJ/CD. When selecting the oil viscosity, pick the grade that is right for the lowest temperature expected. Oil that is too thick can result in a lack of lubrication when the engine is started. If the ambient temperature is consistently below -13°F (-25°C), use a SAE5W *synthetic* oil.

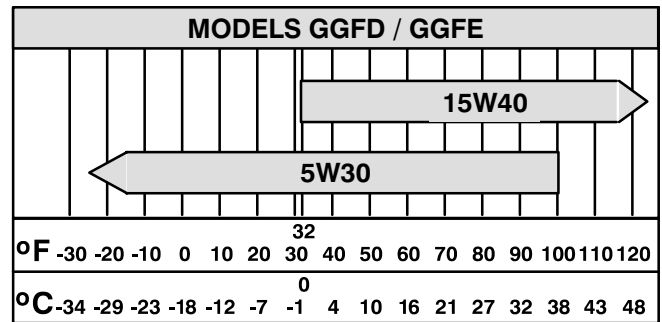

FIGURE 5-1. OIL VISCOSITY

## Engine Oil Level

Check the engine oil level during engine shutdown periods at the intervals specified in the Maintenance Table. The dipstick is stamped with FULL and ADD to indicate the level of oil in the crankcase. For accurate readings, shut off the engine and wait approximately 10 minutes before checking the engine oil level. This allows oil in the upper portion of the engine to drain back into the crankcase.

**⚠ WARNING** *Crankcase pressure can blow out hot oil and cause severe burns. Do NOT check oil while the generator set is operating.*

Keep the oil level as near as possible to the FULL mark on the dipstick. Remove the oil fill cap and add oil of the same quality and brand when necessary.

**⚠ CAUTION** *Do not operate the engine with the oil level below the ADD mark or above the FULL mark. Overfilling can cause foaming or aeration of the oil. Operation below the ADD mark can cause loss of oil pressure.*

## Engine Oil Change

**⚠ WARNING** *State or federal agencies have determined that contact with used engine oil can cause cancer or reproductive toxicity. Do not contact oil or breath vapors. Use rubber gloves and wash exposed skin.*

*Used oil and filters must be disposed of properly to avoid environmental damage and clean-up liability. Check all federal, state and local regulations for disposal requirements.*

Run engine until thoroughly warm before draining oil. Stop the set, place a pan under the drain outlet and remove the oil drain plug or open the drain valve. After the oil is completely drained, replace the drain plug or close the drain valve. Refill with oil of the correct API viscosity grade for the temperature conditions.

**⚠ WARNING** *Hot crankcase oil can cause burns if it is spilled or splashed on skin. Keep fingers and hands clear when removing the oil drain plug and wear protective clothing.*

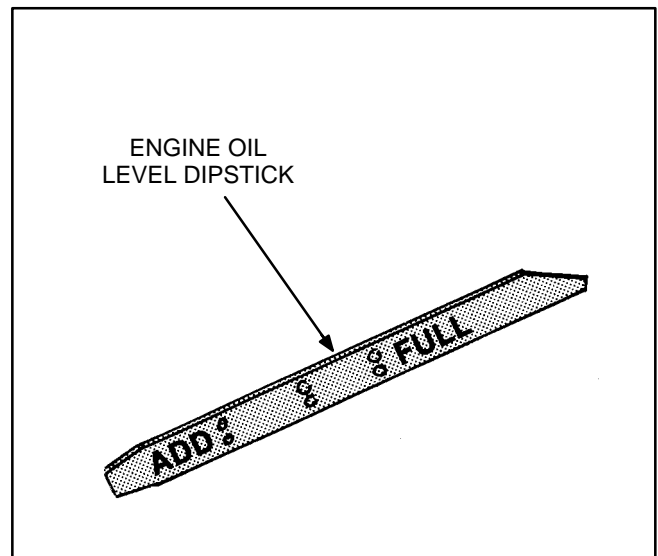

FIGURE 5-2. OIL LEVEL DIPSTICK

## Oil Filter Change

Spin off oil filter and discard it in accordance with local environmental regulations. Thoroughly clean filter mounting surface.

**CAUTION** Fill the heavy duty oil filter with clean lubricating oil before installing it on the engine. Lack of engine lubrication while the filter is being pumped full of oil may be harmful to the engine.

Fill the oil filter with clean lubricating oil. To fill, pour the oil into the center hole of the filter.

Apply a thin film of oil to filter gasket and install new element. Spin element on by hand until gasket just touches mounting pad and then turn an additional 1/2 to 3/4 turn. Do not overtighten (Figure 5-3).

With oil in crankcase, start engine and check for leaks around filter element. Retighten only as much as necessary to eliminate leaks but do not overtighten.

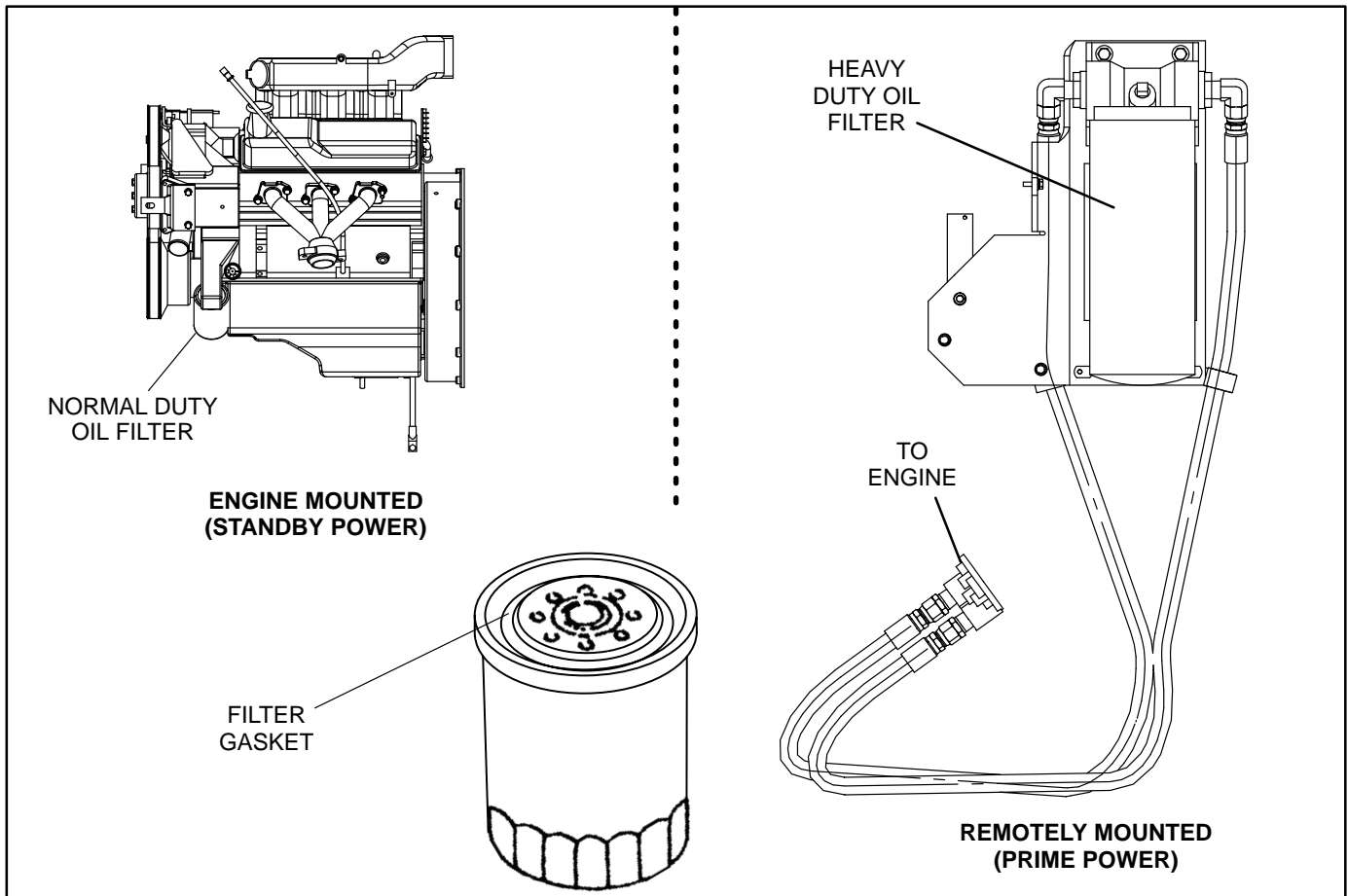

FIGURE 5-3. ENGINE OIL FILTER

## COOLING SYSTEM

The cooling system capacity of a standard unit with set mounted radiator is shown in Specifications section.

**Gensets are shipped with coolant added. Be sure to check coolant level before initial start.**

### Coolant Requirements

Satisfactory engine coolant inhibits corrosion and if necessary protects against freezing. Use a 50/50 coolant solution (50% pure water and 50% anti-freeze). If temperatures below -37° F (-38° C) are possible, use a mixture of 65% antifreeze and 35% water. Do not use an antifreeze that contains anti-leak additives.

The water used for engine coolant should be clean, low in mineral content and free of any corrosive chemicals such as chloride, sulfate or acid. Use soft water. Well water often contains lime and other materials which eventually can clog the radiator core and reduce the cooling efficiency and can also cause heater element failure.

### Filling the Cooling System

**CAUTION** *The engine can overheat and be damaged if coolant is filled improperly.*

Check to make sure that all drain cocks are closed and all hose clamps secure. Remove the radiator

pressure cap and slowly fill the cooling system with the recommended coolant.

**CAUTION** *Do not add cold coolant to a hot engine. Engine castings can be damaged. Allow the engine to cool to below 120° F (50° C) before adding coolant.*

When the engine is first started, remove the pressure cap and monitor the coolant level. As trapped air is expelled from the system, the coolant level may drop and additional coolant must be added. Replace the pressure cap when the coolant level is stable.

### Coolant Level

Check the coolant level during shutdown periods at the intervals shown in Table 5-1. Remove the radiator cap after allowing the engine to cool and if necessary, add coolant until the level is near the top of the radiator.

**WARNING** *To prevent severe scalding, let engine cool down before removing coolant pressure cap. Turn cap slowly, and do not open it fully until the pressure has been relieved.*

**CAUTION** *Loss of coolant can allow engine to overheat without protection of shutdown device and cause severe damage to the engine. Maintain coolant level for proper operation of the high engine temperature shutdown system.*

## Draining and Flushing

**⚠ WARNING** *Some coolant is toxic. Keep away from children and animals. Follow local environmental regulations for disposal.*

To maintain adequate corrosion protection and remove rust and scale deposits, drain and flush radiator at the recommended interval.

**⚠ CAUTION** *The heater element will burn out if engine coolant is removed with heater connected to power source.*

Disconnect engine coolant heater from power source (if equipped).

Allow the engine to cool and then remove radiator pressure cap. Open the radiator drain cock and remove the water drain plugs (one on each side of engine). When the coolant is drained, place the end of a water hose into the radiator filler and turn on water supply. Regulate the flow of water into the radiator until it is equal to the outflow from drain openings. Continue flushing until outflow from drains is clear of rust sediment.

**If engine is equipped with engine coolant heater, drain coolant by removing hose and clamp from bottom of heater.**

Replace the water drain plugs and close the radiator drain cock when flushing is complete. Refill the cooling system with the recommended coolant (refer to *Filling the Cooling System*).

With cooling system properly filled and the engine has been run, connect heater plug to receptacle.

**⚠ CAUTION** *The heater element will burn out if power is connected before it is filled with coolant or if straight antifreeze solution is used for coolant. Before connecting power, fill the engine with coolant and run it for a while to circulate coolant through the heater.*

## Radiator

Inspect the exterior of the radiator for obstructions. Remove all dirt or foreign material with a soft brush or cloth. Use care to avoid damaging the fins. If available, use low pressure compressed air or stream of water (maximum of 35 psi/242 kPa), in opposite direction of normal air flow to clean radiator. If using water, protect the engine and the generator from over spray.

## Coolant Heater

Check the operation of the coolant heater by verifying that hot coolant is being discharged from the outlet hose. **Do not touch outlet hose** – if heater is operational, radiant heat should be felt with hand held close to outlet hose.

**⚠ WARNING** *Contact with cooling system or engine can result in serious burns. Do not touch cooling system or engine during genset maintenance until they are cool.*

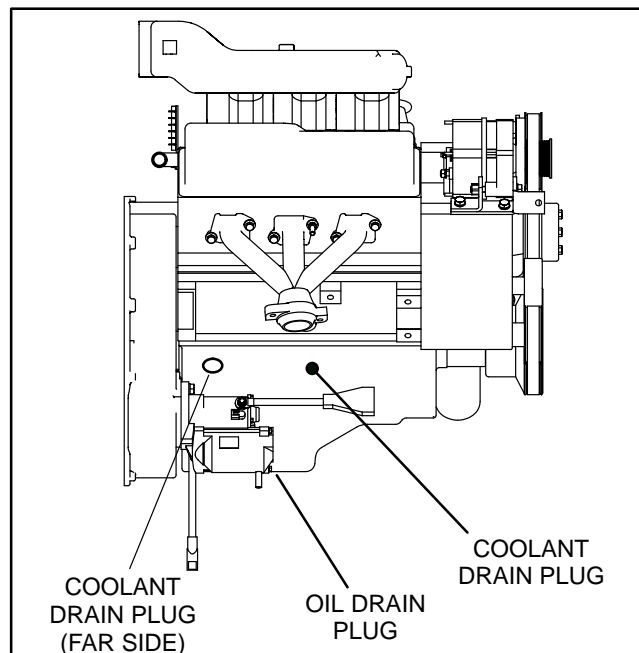

FIGURE 5-4. DRAIN PLUG LOCATIONS

## AIR FILTERS

### Heavy Duty Air Filter (Figure 5-5)

Clean filter element every 100 hours of operational time or sooner if the service indicator button pops up indicating air restriction. Replace air filter after 2000 hours of operational time.

Inspect all components of the air filtering system including all ducts and hoses. The vacuator valve dumps collected dust automatically. Verify that all connections and clamps are tight and inspect each component for cracks, dents, or other damage. Repair or service as required.

**CAUTION** *Filters should be handled with care to prevent damage. If the filter does become damaged, install recommended replacement part.*

The following procedure should be followed when cleaning or replacing the element.

1. Release the three cover clips and remove the air cleaner cover.
2. Slowly remove the air filter to reduce the amount of dust dislodged. There may be some initial resistance when removing the filter.

Gently move the end of the filter up and down and side to side or twist to break the seat.

3. Wipe out the interior of the air cleaner housing and cover with a clean, damp cloth. Make sure that **ALL** dust is removed from **ALL** interior surfaces of the air cleaner housing. Be careful not to damage the sealing area on the outlet tube.
4. **CLEAN:** Tap filter on a flat surface to remove dirt. Place a light source inside filter and inspect for air passage. If necessary, apply a low pressure air source (30 psi) to the inside of filter to remove as much dirt as possible.

**NEW:** Inspect new air filter for shipping damage. Pay attention to the inside of the open end (sealing area). Do not install a damaged filter.

5. Install air filter. The seal area is on the inside of the open end of the filter. The sealing area will stretch slightly and adjust itself over the outlet tube. To complete the seal, apply pressure at the outer rim of the filter, not the flexible center. No cover pressure is required to hold the seal.
6. Install the air cleaner cover (with vacuator valve pointed downward) and secure with the three cover clips.

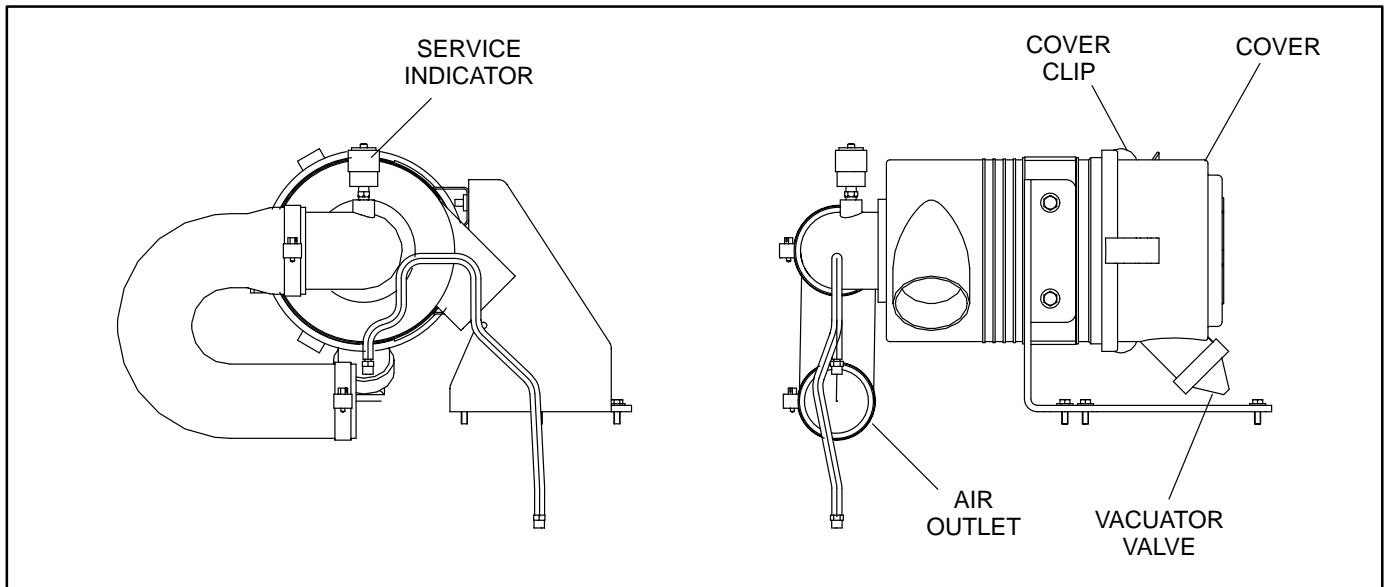

FIGURE 5-5. HEAVY DUTY AIR CLEANER

### Normal Duty Air Filter (Figure 5-6)

Clean air filter every 100 hours of operational time, more often in extremely dust conditions. Replace air filter after 500 hours of operational time.

The following procedure should be followed when cleaning or replacing the element.

1. Remove wing nut in center of filter cover (Figure 5-6).
2. Remove cover and filter. Tap filter on a flat surface to remove dirt.
3. Place a light source inside filter and inspect for air passage. If necessary, apply a low pressure air source (30 psi) to the inside of filter to remove as much dirt as possible.
4. Install air filter and cover and secure with wing nut.

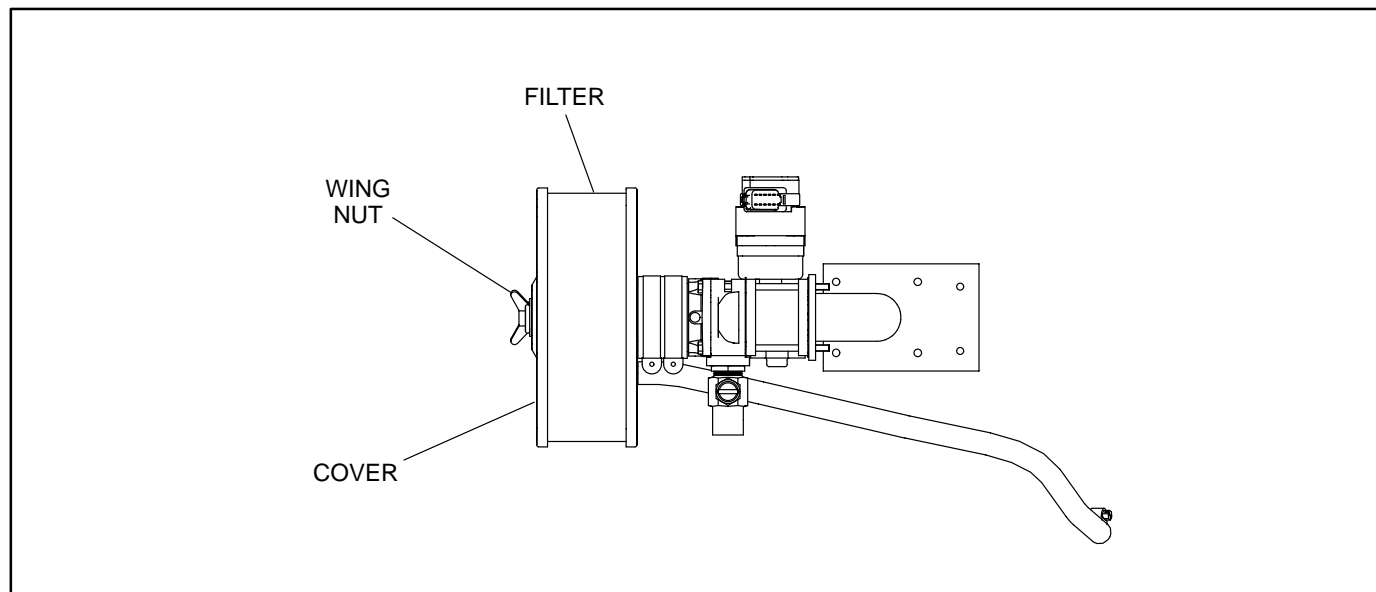

FIGURE 5-6. NORMAL DUTY AIR CLEANER

## SERPENTINE BELT REPLACEMENT

### Belt Removal

1. Disconnect the negative (–) cable from the battery to prevent accidental starting.
2. Remove starter side fan guard (between engine and radiator) to gain access to the serpentine belt.
3. Place a 15 mm socket onto the tensioner arm (Figure 5-7). With handle of ratchet extended horizontally to the right of the tensioner arm, slowly lift up on the ratchet handle until the spring tension is relieved. Remove serpentine belt.

**⚠WARNING** *The belt idler is under tension. Do not allow your hands to get between the belt and pulley. Personal injury will result.*

### Belt Replacement

1. Slip new serpentine belt onto all pulleys except for the alternator pulley.

**⚠WARNING** *The belt idler is under tension. Do not allow your hands to get between the belt and pulley. Personal injury can result.*

2. With handle of ratchet extended horizontally to the right of the tensioner arm, slowly lift up on the ratchet handle until the spring tension is relieved sufficiently to position the belt over the alternator pulley. Slowly release spring tension onto belt.

**The spring-loaded idler used on this design maintains the correct belt tension.**

3. Install fan guard.
4. Connect the negative (–) cable to the battery.
5. Start genset and visually check belt for proper alignment with engine running.

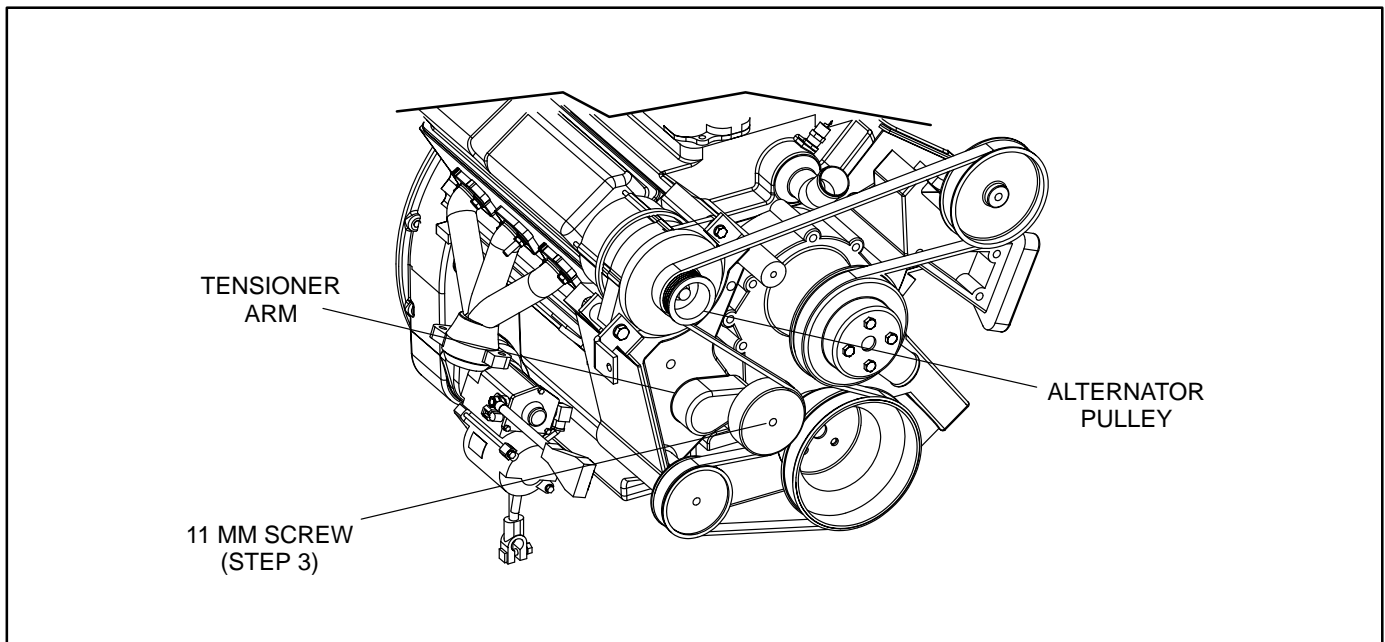

FIGURE 5-7. SERPENTINE BELT REPLACEMENT



## IGNITION SYSTEM

The ignition system consists of ignition module, 6 ignition coils, high tension wires, spark plugs and electronic control module. Maintenance consists of periodic inspections to detect possible problems and replacement of worn or deteriorated parts. The ignition system must be completely functional or the set may run poorly or be unable to carry full load. Perform the following inspections at recommended intervals.

### Spark Plugs

Remove the spark plugs and inspect every 1,000 hours for damaged or cracked insulators, worn electrodes, or excessive carbon deposits. Replace the spark plug if any of these conditions are noted. Clean those plugs that can be reused and regap (Figure 5-8) to the amount specified in the Specifications section.

Before installing the spark plugs:

- Clean all dirt and grit away from the spark plug seats.
- Lightly lubricate spark plug threads with high temp anti-seize compound.

If the spark plugs show any of the following conditions, the engine may require additional service. Contact your authorized service distributor for help.

- Carbon Fouled - Overly Rich Mixture
- Oil Fouled - High oil consumption
- Burned - Excessive engine temperature

### High Tension Wires

Check the spark plug wires for good contact at the coils and spark plugs. Terminal connections should be tight and fully seated. All spark plug covers and cable end boots should be in good condition and fit tightly. There should be no breaks or cracks in the insulation. Replace the wire if any of these conditions are noted.

### Ignition Coil

Clean the top of the ignition coil and check for cracks, carbon tracks or corrosion in the high tension terminal hole. Replace the coil if any of these conditions are noted.

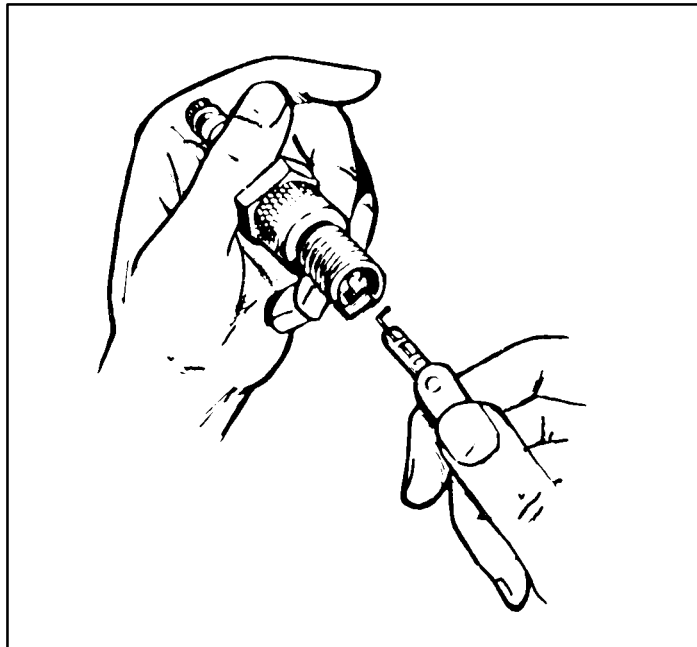

FIGURE 5-8. GAPPING SPARK PLUGS

## BATTERIES

**⚠ WARNING** *Ignition of explosive battery gases can cause severe personal injury or death. Arcing at battery terminals, light switch or other equipment, flame, pilot lights and sparks can ignite battery gas. Do not smoke, or switch trouble light ON or OFF near battery. Discharge static electricity from body before touching batteries by first touching a grounded metal surface.*

*Ventilate battery area before working on or near battery—Wear goggles—Stop genset and disconnect charger before disconnecting battery cables—Disconnect negative (–) cable first and reconnect last.*

**⚠ CAUTION** *Disconnect battery charger from AC source before disconnecting battery cables. Otherwise, disconnecting cables can result in voltage spikes damaging to DC control circuits of the set.*

Check the condition of the starting batteries at the interval specified in the Maintenance Table. To prevent dangerous arcing, always disconnect the negative ground cable from the battery before working on any part of the electrical system or the engine. Disregard the sections On Checking Specific Gravity and Checking Electrolyte Level if using a “maintenance-free” battery.

### Cleaning Batteries

**⚠ WARNING** *Electrolyte is a dilute sulfuric acid that is harmful to the skin and eyes. Do not get the substance in your eyes or contact with skin. Wear goggles and protective, rubber gloves and apron when servicing batteries.*

*In case of contact, immediately wash skin with soap and water. In case of contact, immediately flood eyes with large amounts of water for a minimum of 15 minutes. IMMEDIATELY CALL A PHYSICIAN.*

Keep the batteries clean by wiping them with a damp cloth whenever dirt appears excessive.

If corrosion is present around the terminal connections, remove battery cables and wash the terminals with a solution consisting of 1/4 pound of baking soda added to 1 quart of water. (This solution is also used for washing down spilled electrolyte.)

Be sure the vent plugs are tight to prevent cleaning solution from entering the cells.

After cleaning, flush the outside of the battery and surrounding areas with clean water.

Keep the battery terminals clean and tight. After making connections, coat the terminals with a light application of petroleum jelly or non-conductive grease to retard corrosion.

### Checking Specific Gravity

Use a battery hydrometer to check the specific gravity of the electrolyte in each battery cell.

Hold the hydrometer vertical and take the reading. Correct the reading by adding four gravity points (0.004) for every ten degrees the electrolyte temperature is above 80° F (27° C). A fully charged battery will have a corrected specific gravity of 1.260. Charge the battery if the reading is below 1.215.

### Checking Electrolyte Level

**⚠ CAUTION** *Do not add water in freezing weather unless the engine will run long enough (two to three hours) to assure a thorough mixing of water and electrolyte.*

Check the level of the electrolyte (acid and water solution) in the batteries at least every 200 hours of operation.

Fill the battery cells to the bottom of the filler neck. If cells are low on water, add distilled water and recharge. If one cell is low, check case for leaks. Keep the battery case clean and dry. An accumulation of moisture will lead to a more rapid discharge and battery failure.

### Battery Replacement

Always replace the starting battery with the same number and type (vented, lead acid). Properly dispose of battery in accordance with local environmental agency requirements.

**⚠ WARNING** *Electrolyte or explosion of battery can cause severe personal injury or death. Do not mutilate or burn the battery in a fire for disposal.*

*Damage to case will release electrolyte which is harmful to the skin and eyes and is also toxic. Burning of battery may cause an explosion.*

## OUT-OF-SERVICE PROTECTION

When the set will be stored or removed from operation for an extended period of time, take the following precautions to prevent rust accumulation, corrosion of bearing surfaces within the engine and gum formation in the fuel system. Perform the following procedures as outlined in this manual.

### Preparing Set for Storage

1. Exercise the set as described in Operation section until the engine is up to operating temperature.
2. Shut down the engine.
3. Turn off and disconnect battery charger (if equipped).
4. Disconnect battery (negative [-] first) and store in a cool, dry place. Connect battery to charger every 30 days to maintain it at full charge.
5. Drain the engine oil while still warm and refill with new oil recommended for set. Attach a tag indicating type of oil used.
6. Remove the spark plugs and pour two ounces of rust preventative oil into each spark plug opening. Crank the set for five seconds to distribute the oil on the cylinder walls and then replace the spark plugs.
7. Disconnect engine coolant heater from power source (if equipped).
8. Drain the cooling system including the engine block.

9. Remove the air cleaner and seal off the carburetor air inlet opening and PVC hose.
10. Plug the exhaust outlets to prevent entrance of moisture, bugs, dirt, etc.
11. Clean and wipe entire unit. Coat parts susceptible to rust with a light coat of oil. Cover entire set loosely after engine has cooled down.

### Returning Set to Service

1. Remove protective cover.
2. Remove exhaust plugs, seal from carburetor and PVC hose and replace air cleaner.
3. Check oil dipstick to make sure crankcase is full.
4. Refill cooling system.
5. Reconnect battery (positive [+] cable first) and check specific gravity.
6. Connect the battery charger (if applicable).
7. Connect engine coolant heater to power supply (if applicable).
8. Remove all loads before starting set.
9. Start set and apply load of at least 50% of nameplate rating.
10. Check all gauges for normal readings. Set is now ready for service.

# 6. Adjustments

## OUTPUT VOLTAGE ADJUSTMENT

Output voltage can be adjusted plus or minus five percent of nominal voltage by the Voltage Adjust rheostat (optional) on the control panel (Figure 3-3). Call your distributor if the required voltage cannot be obtained by this adjustment.

## FUEL SYSTEM ADJUSTMENTS

The engine is equipped with a gas mixer to run on natural gas or LPG or both.

**⚠WARNING** *Fuel is highly flammable and may cause severe personal injury and property damage. Do not allow cigarettes, flame, pilot lights, arching switches or equipment in area or areas sharing ventilation.*

## Gaseous and Combination Fuel Systems

An engine equipped for natural gas and LPG has a gas mixer that serves both fuels. Each fuel has a separate shutoff solenoid valve and a fuel pressure switch for automatic fuel changeover.

While the engine is running, the gas pressure switch causes the natural gas solenoid valve to close and the LPG solenoid valve to open when natural gas pressure is lost, without stopping the engine. When natural gas pressure is restored, the natural gas solenoid valve opens and the LPG solenoid valve closes.

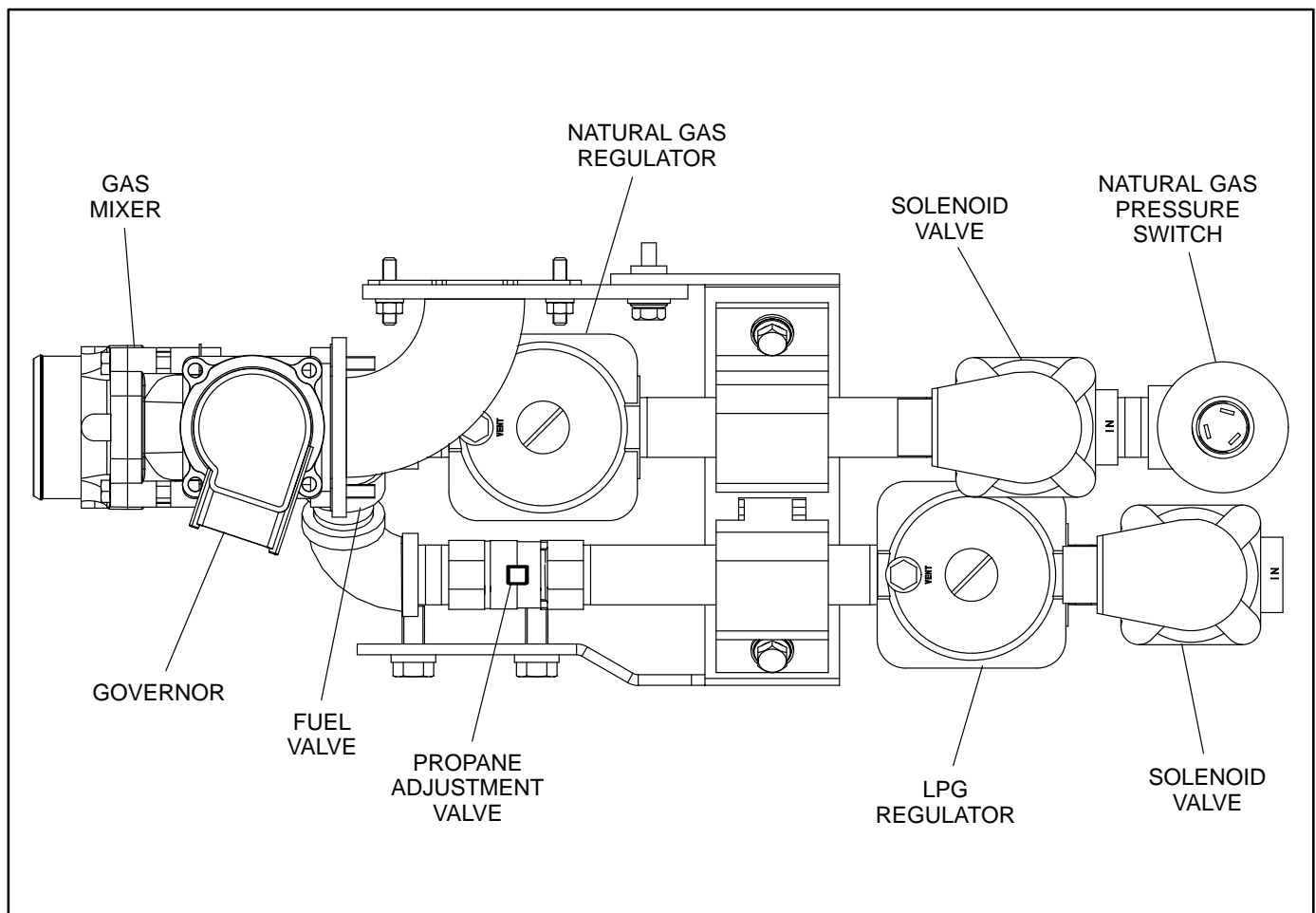

FIGURE 6-1. NATURAL GAS AND LPG VAPOR FUEL SYSTEM

**Gaseous Fuel Adjustments:** The fuel system contains either a manual fuel valve, which may require adjustment or an automatic fuel control valve (no adjustment required) as shown in Figure 6-2.

Engines equipped for natural gas and propane (dual fuel) also have a propane flow adjustment valve. If necessary, make the following adjustments.

**For applications in emission sensitive areas, final adjustment of the fuel/air ratio should be set using an exhaust gas analyzer.**

1. Start the engine and let the set warm up under a partial load (at least 1/4 rated load). If the engine is equipped for natural gas and propane, start with natural gas.

2. Connect full rated load and turn the power adjust valve two turns counterclockwise. Slowly turn the manual fuel valve clockwise (lean) until the engine begins to lose speed and then slowly counterclockwise (rich) until the engine carries the full load smoothly.
3. If the set is equipped for natural gas and LPG, switch to LPG by closing the manual shutoff valve in the natural gas supply line.
4. Reconnect full rated load and turn the LPG flow adjustment valve clockwise until the engine begins to lose speed and then slowly turn it back counterclockwise until the engine carries full load smoothly.

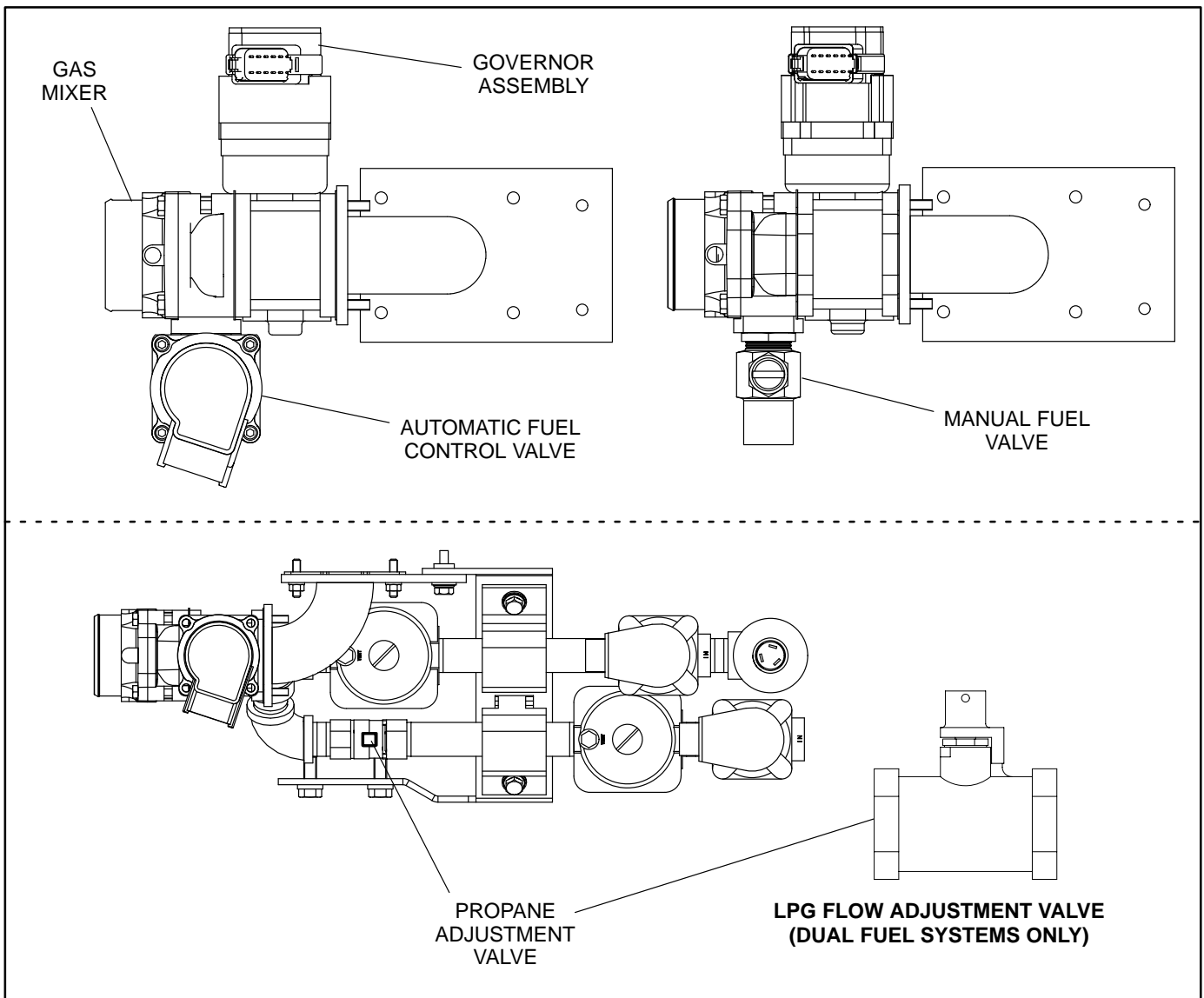

**FIGURE 6-2. GASEOUS FUEL ADJUSTMENTS**

# 7. Operating Recommendations

---

## BREAK-IN

Drain and replace the crankcase oil after the first 50 hours of operation on new generator sets. Refer to the *Maintenance* section of this manual for the recommended procedures.

## NO-LOAD OPERATION

Periods of no load operation should be held to a minimum. If it is necessary to keep the engine running for long periods of time when no electric output is required, best engine performance will be obtained by connecting a load bank of at least 30 percent of nameplate rating.

## EXERCISE PERIOD

Generator sets on continuous standby must be able to go from a cold start to being fully operational in a matter of seconds. This can impose a severe burden on engine parts.

Regular exercising keeps engine parts lubricated, prevents oxidation of electrical contacts and in general helps provide reliable engine starting.

Exercise the generator set at least once a month for a minimum of 30 minutes, under not less than 30 percent of the nameplate rating.

## LOW OPERATING TEMPERATURE

Use a coolant heater if a separate source of power is available. The optional heater will help provide reliable starting under adverse weather conditions. Be sure the voltage of the separate power source is correct for the heater element rating.

**⚠ CAUTION** *To avoid damage to heater, be sure the cooling system is full before applying power to the heater.*

## HIGH OPERATING TEMPERATURE

Refer to the genset nameplate for the maximum ambient operating temperature, if applicable.

**THIS PAGE LEFT INTENTIONALLY BLANK**

**Cummins Power Generation**  
1400 73rd Avenue N.E.  
Minneapolis, MN 55432  
1-800-888-6626  
763-574-5000 International Use  
Fax: 763-528-7229

Cummins is a registered trademark of Cummins Inc.



Redistribution or publication of this document  
by any means, is strictly prohibited.