

Onan

Operator's Manual

Performer

P216V

P218V

P220V

Engine

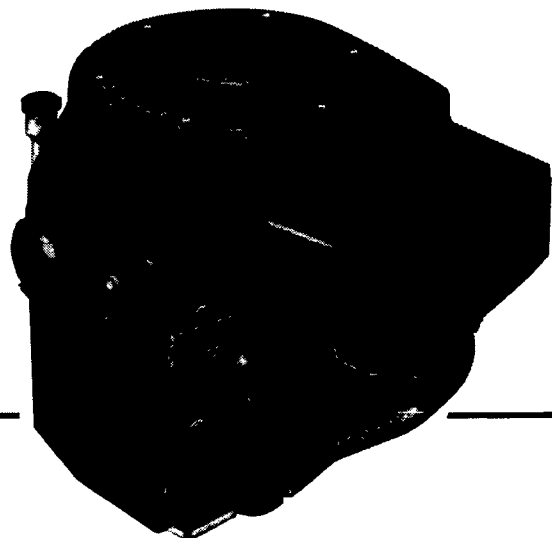

Safety Precautions

It is recommended that you read your engine manual and become thoroughly acquainted with your equipment before you start the engine.

⚠ DANGER *This symbol if used warns of immediate hazards which will result in severe personal injury or death.*

⚠ WARNING *This symbol refers to a hazard or unsafe practice which can result in severe personal injury or death.*

⚠ CAUTION *This symbol refers to a hazard or unsafe practice which can result in personal injury or product or property damage.*

Fuels, electrical equipment, batteries, exhaust gases and moving parts present potential hazards that can result in serious, personal injury. Take care in following these recommended procedures. All local, state and federal codes should be consulted and complied with.

⚠ WARNING *This engine is not designed or intended for use in any type of aircraft. Use of this engine in aircraft can result in engine failure and causes serious personal injury or death.*

General

- Provide appropriate fire extinguishers and install them in convenient locations. Use an extinguisher rated ABC by NFPA.
- Make sure that all fasteners on the engine are secure and accurately torqued. Keep guards in position over fans, driving belts, etc.
- If it is necessary to make adjustments while the engine is running, use extreme caution when close to hot exhausts, moving parts, etc.

Protect Against Moving Parts

- Do not wear loose clothing in the vicinity of moving parts, such as PTO shafts, flywheels, blowers, couplings, fans, belts, etc.
- Keep your hands away from moving parts.

Batteries

- Before starting work on the engine, disconnect batteries to prevent inadvertent starting of the engine.
- DO NOT SMOKE while servicing batteries. Lead acid batteries give off a highly explosive hydrogen gas which can be ignited by flame, electrical arcing or by smoking.
- Verify battery polarity before connecting battery cables. Connect negative cable last.

Fuel System

- DO NOT fill fuel tanks while engine is running.
- DO NOT smoke or use an open flame in the vicinity of the engine or fuel tank. Internal combustion engine fuels are highly flammable.
- Fuel lines must be of steel piping, adequately secured, and free from leaks. Piping at the engine should be approved flexible line. Do not use copper piping for flexible lines as copper will work harden and become brittle enough to break.
- Be sure all fuel supplies have a positive shutoff valve.

Exhaust System

- Exhaust products of any internal combustion engine are toxic and can cause injury, or death if inhaled. All engine applications, especially those within a confined area, should be equipped with an exhaust system to discharge gases to the outside atmosphere.
- Do not use exhaust gases to heat a compartment.
- Make sure that your exhaust system is free of leaks. Ensure that exhaust manifolds are secure and are not warped by bolts unevenly torqued.

Exhaust Gas is Deadly!

Exhaust gases contain carbon monoxide, a poisonous gas that can cause unconsciousness and death. It is an odorless and colorless gas formed during combustion of hydrocarbon fuels. Symptoms of carbon monoxide poisoning are:

- Dizziness
- Headache
- Weakness and Sleepiness
- Vomiting
- Muscular Twitching
- Throbbing in Temples

If you experience any of these symptoms, get out into fresh air immediately, shut down the unit and do not use until it has been inspected.

The best protection against carbon monoxide inhalation is proper installation and regular, frequent inspections of the complete exhaust system. If you notice a change in the sound or appearance of exhaust system, shut the unit down immediately and have it inspected and repaired at once by a competent mechanic.

Cooling System

- Coolants under pressure have a higher boiling point than water. DO NOT open a radiator pressure cap when coolant temperature is above 212°F (100°C) or while engine is running.

Keep the Unit and Surrounding Area Clean

- Make sure that oily rags are not left on or near the engine.
- Remove all unnecessary grease and oil from the unit. Accumulated grease and oil can cause overheating and subsequent engine damage and present a potential fire hazard.

Table of Contents

TITLE	PAGE
Introduction	2
Engine Set-Up	3
Operation	4
Maintenance	6
Periodic Maintenance Schedule	9
Adjustments	10

▲WARNING

INCORRECT SERVICE OR REPLACEMENT OF PARTS CAN RESULT IN SEVERE PERSONAL INJURY AND/OR EQUIPMENT DAMAGE. SERVICE PERSONNEL MUST BE QUALIFIED TO PERFORM ELECTRICAL AND/OR MECHANICAL SERVICE.

▲WARNING: ▲

The engine exhaust from this product contains chemicals known to the State of California to cause cancer, birth defects or other reproductive harm.

Introduction

KNOW YOUR ENGINE

Read this manual carefully, observing all **WARNINGS** and **CAUTIONS**. Operating instructions, adjustments and periodic maintenance procedures are given so you, the owner, can keep your unit running like new and expect many years of dependable service from it. Remember . . . any machine, regardless of design or type, will perform only in relation to the service it receives. Regularly scheduled maintenance lowers operating costs.

ENGINE MODEL REFERENCE

Identify your model by referring to the **MODEL** and **SPEC** (specification) **NO.** as shown on the unit nameplate.

Always use this number and the engine serial number when making reference to your engine.

If a major repair or an overhaul is necessary, Onan recommends the work be done by a competent mechanic to ensure that all dimensions, clearances, and torque values are within the specified tolerances.

An engine **SERVICE MANUAL** and complete **PARTS MANUAL** are available at additional cost. Contact your nearest authorized dealer or Onan Parts and Service Center.

This manual contains the SI metric equivalents following immediately in parentheses after the U.S. customary units of measure.

SPECIFICATIONS

SPECIFICATION	UNIT OF MEASURE	SERIES		
		P216V	P218V	P220V
Number of Cylinders		2	2	2
Bore	in (mm)	3.250 (82.55)	3.250 (82.55)	3.250 (82.55)
Stroke	in (mm)	2.620 (66.55)	2.875 (73.03)	2.875 (73.03)
Displacement	cu in (cm ³)	43.3 (710)	47.7 (782)	47.7 (782)
Compression Ratio		6.5 to 1	7.0 to 1	7.0 to 1
Power at Rated Speed (3600 rpm)	BHP (kW)	16 (11.9)	18 (13.4)	20 (14.9)
Oil Capacity				
Standard Base Without Filter	Qts (litre)	1.7 (1.6)	1.7 (1.6)	1.7 (1.6)
Oil Filter Capacity	Qts (litre)	.3 (.3)	.3 (.3)	.3 (.3)
Valve Clearance (Cold)				
Intake	in (mm)	.005 (.13)	.005 (.13)	.005 (.13)
Exhaust	in (mm)	.013 (.33)	.013 (.33)	.013 (.33)
Spark Plug Gap	in (mm)	.025 (.64)	.025 (.64)	.025 (.64)
Ignition Timing	BTC	20°	20°	20°

Engine Set-Up

Inspect the engine visually. Check for loose or missing parts and any damage that may have occurred in shipment.

CAUTION Starting engine without oil will result in severe engine damage. Add oil prior to starting engine.

BATTERY

The battery and battery cables used for starting the engine should be of sufficient size to provide prompt starting. Undersized battery will result in poor starter operation and a very short starter service life.

WARNING Ignition of explosive battery gases can result in severe personal injury. Do not smoke or allow any ignition source near the battery.

CAUTION Reversing positive and negative battery connections or allowing engine to run without being connected to the alternator will result in engine electrical system damage. Do not switch battery connections or allow engine to run without being connected to the alternator.

CRANKCASE OIL RECOMMENDATIONS

Fill crankcase with correct amount of oil. Refer to *Specifications* for crankcase capacity. Use oils meeting the API classification SF, SF/CC, or SF/CD. Refer to chart below to determine the proper viscosity grade of oil to use. Straight weight oils are recommended for severe duty use and at temperatures above 32°F (0°C) for minimum oil consumption.

WARNING Crankcase pressure can blow out hot oil, which can cause severe personal injury. Do not check oil while the engine is running.

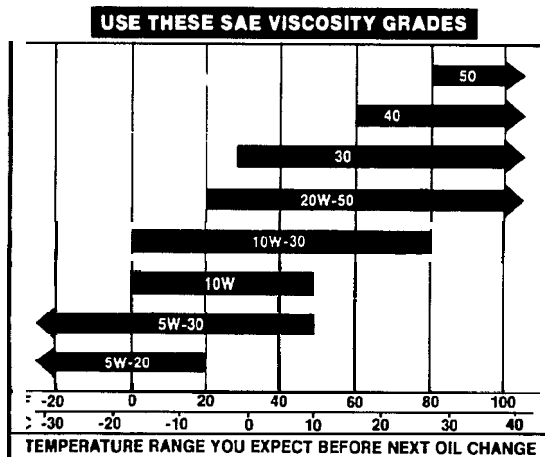

LS-1170

CAUTION Excess oil can cause high oil consumption, high operating temperatures, and oil foaming. Do not overfill crankcase.

Oil Level

Check oil level as recommended in *Periodic Maintenance Schedule*. Check more frequently on a new or reconditioned engine as oil consumption is higher until the piston rings seat properly.

When adding oil between oil changes, it is preferable to use the same brand, as various brands of oil may not be compatible together. Refer to *MAINTENANCE* for recommended oil change intervals and procedures.

FUEL RECOMMENDATIONS

WARNING Ignition of fuel can result in severe personal injury or death. Do not smoke or allow any spark, pilot light, or arcing equipment near the fuel system.

Use clean, fresh, unleaded gasoline. Regular leaded gasoline may also be used but is not a preferred fuel. Do not use highly leaded premium gasoline. Use of unleaded gasoline results in less maintenance.

CAUTION Gasoline de-icers and fuel containing alcohol can cause poor engine performance and engine damage. Do not use fuel system de-icers. Do not use gasoline containing alcohol concentrations greater than ten percent.

If regular leaded gasoline is used continually, carbon and lead deposits should be removed from the cylinder heads as required because of engine power loss. Unleaded gasoline may be used safely after lead deposits have been removed.

WARNING Ignition of fuel can result in severe personal injury or death. Thoroughly clean up any spilled fuel.

EXHAUST SYSTEM

Exhaust products of any internal combustion engine are toxic and can cause injury, or death if inhaled. All engine applications, especially those within a confined area, should be equipped with an exhaust system to discharge gases to the outside atmosphere.

WARNING Breathing exhaust gases can result in severe personal injury or death. Use extreme care during installation to ensure a leak-free exhaust system.

Operation

STARTING

Most engines are equipped with a start-stop switch and cable controlled choke and throttle.

1. Place the throttle control in the *SLOW* position and the choke into the *FULL* choke position.
2. Turn the ignition switch on and engage starter. If engine fails to start after 30 seconds determine the cause. Wait one minute before re cranking. If the engine fails to start at first attempt, rust inhibitor oil used at the factory may have fouled the plugs. Remove the plugs, clean in a suitable solvent, dry thoroughly and reinstall. Heavy exhaust smoke when the engine is initially started is normal and usually caused by rust inhibitor oil.
3. When the engine starts, gradually push the choke lever in until the engine runs smoothly. Black smoke from the exhaust and a rough running engine usually indicate over-choking.
4. To stop the engine, turn the ignition switch to the *OFF* position.

BREAK-IN PROCEDURE

Controlled break-in is the ideal fitting of all internal moving metal parts. Using the proper oil and applying a conscientious maintenance program during this period helps assure satisfactory service from your Onan engine.

Maintain the proper cooling and lubrication during break-in. Run the engine at half load for the first three hours with intermittent periods of full load to control engine break-in.

CAUTION *Using the wrong grade and weight of oil and high engine operating temperatures during break-in can cause engine damage. Use correct oil grade and weight and provide adequate engine cooling during engine break-in.*

Check the oil level at least every five operating hours. Add oil to keep it at the proper level, but never overfill as overfilling may cause the oil to foam and enter the breather system, resulting in high oil consumption and oil accumulation in air cleaner housing.

HOT WEATHER OPERATION

When operating the engine in temperatures above 100°F (38°C), pay particular attention to the following items to prevent damage:

1. Keep the engine cooling fins clean and free of obstruction.

CAUTION *Plugged or clogged cooling fins can cause overheating and engine damage. Ensure cooling fins are kept clean and debris does not accumulate.*

WARNING *Contact with rotating machinery can result in severe personal injury or death. Stay clear of rotating components and ensure protective shields and guards are in place and secured before operating machinery.*

2. See that nothing obstructs air flow to and from the engine.
3. Ensure that you are using the proper grade and weight of oil for ambient temperatures. Check the oil level each time you fill the fuel tank.
4. Check the battery water more frequently. High temperatures cause faster evaporation.
5. Change crankcase oil and filter more frequently.

COLD WEATHER OPERATION

When the engine is being used in temperatures below 32°F (0°C), check the following items closely:

1. Use the correct grade and weight of oil for the temperature conditions. Change the oil only when the engine is warm. If an unexpected temperature drop occurs when the engine is filled with summer oil, before starting the engine, move it to a warm location until the oil will flow freely.
2. Use fresh fuel. Fill the fuel tank after each day's use to protect against moisture condensation.
3. Keep the battery in a well-charged condition.

DUST AND DIRT

1. Keep unit clean. Keep cooling system clean.
2. Service air cleaner as frequently as required.
3. Change crankcase oil and filter more often.

OUT-OF-SERVICE PROTECTION

Protect an engine that will be out-of-service for more than 30 days as follows:

1. Run the engine until it reaches normal operating temperature.
2. Turn off the fuel supply and run the engine until it stops.
3. Drain oil from oil base while the engine is still warm. Refill with fresh crankcase oil and attach a tag stating viscosity used.

4. Remove spark plugs. Pour 1 ounce (2 tablespoons or 28 grams) of rust inhibitor or SAE #50 oil into the cylinders. Crank the engine over a few times. Reinstall spark plugs.
5. Service air cleaner as outlined in *MAINTENANCE*.
6. Clean governor linkage and protect by wrapping with a clean cloth.
7. Plug exhaust outlet to prevent entrance of moisture, dirt, bugs, etc.
8. Wipe entire unit. Coat rustable parts with a light film of grease or oil.
9. Provide a suitable cover for the entire unit.
10. If battery equipped, disconnect and follow standard battery storage procedure.

RETURNING UNIT TO SERVICE

1. Remove cover and all protective wrapping. Remove plug from exhaust outlet.
2. Check tag on oil base and verify that oil viscosity is still correct for existing ambient temperatures.
3. Clean and check battery. Measure specific gravity (1.260 at 77°F [25°C]) and verify level to be at split ring. If specific gravity is low, charge until correct value is obtained. If the level is low, add distilled water and charge until specific gravity is correct.
4. Check that fuel filter and fuel lines are secure, with no leaks.
5. Check that carburetor throttle lever and governor linkage move freely.
6. Connect battery.
7. Start engine. Exhaust smoke is normal when the engine is started and is usually caused by the rust inhibitor oil.



EXHAUST GAS IS DEADLY!

Exhaust gases from all fuels (including diesel, gasoline, liquid propane, natural gas) contain carbon monoxide, an odorless and colorless gas. Carbon monoxide is poisonous and can cause unconsciousness and death. Symptoms of carbon monoxide poisoning can include:

- ***Dizziness***
- ***Nausea***
- ***Headache***
- ***Weakness and Sleepiness***
- ***Throbbing in Temples***
- ***Muscular Twitching***
- ***Vomiting***
- ***Inability to Think Coherently***

IF YOU OR ANYONE ELSE EXPERIENCE ANY OF THESE SYMPTOMS, GET OUT INTO THE FRESH AIR IMMEDIATELY. If symptoms persist, seek medical attention. Shut down the unit and do not operate until it has been inspected and repaired.

Protection against carbon monoxide inhalation includes proper installation, ventilation and regular, frequent visual and audible inspections of the complete exhaust system.

Maintenance

⚠ WARNING *Accidental starting of the engine can result in severe personal injury or death. Disconnect the negative battery cable and spark plug wires while servicing engine, controls, or associated equipment.*

DAILY CHECKS OR EVERY 8 HOURS

The operator should daily make a complete visual and audible inspection of the engine. Check the following before starting the engine for the first time each day:

1. Check all fuel lines and fittings for possible leakage.
2. Inspect exhaust system for possible leakage and cracks. Locate leaks in muffler and piping while the engine is operating. Repair all leaks immediately after they are detected for personal safety.
3. Inspect air cleaner system for leaks. Make certain all clamps and fittings are tight and free of potential leaks.

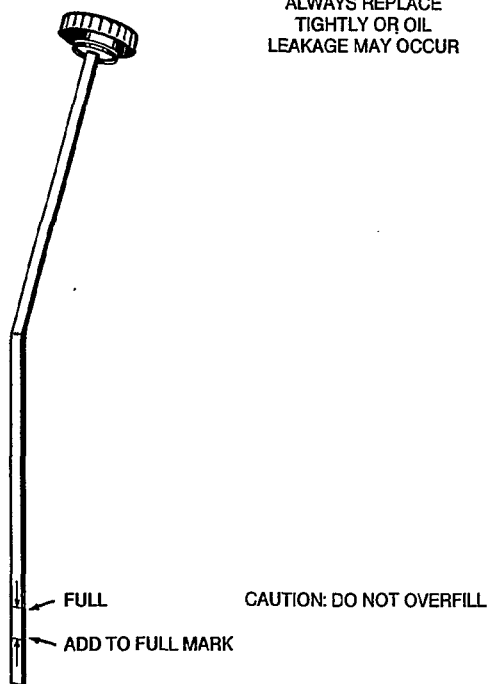

FIGURE 1. CRANKCASE OIL FILL

4. Check crankcase oil level with the engine off. If engine has been run, allow a minimum of 10 minutes for the oil to drain down before checking. If oil level is at or below ADD mark on dipstick (Figure 1), add sufficient oil of the proper viscosity as specified in *ENGINE SET-UP* to bring oil level to the FULL mark. Do not operate engine with oil level below the ADD mark.

OIL CHANGE

Refer to the *Periodic Maintenance Schedule* for oil change intervals.

Run engine until thoroughly warm before draining oil. Stop the engine, place a pan under the drain outlet and remove the oil drain plug or open the drain valve. After the oil is completely drained, replace the drain plug or close the drain valve. Refill with oil of the correct API classification and appropriate SAE viscosity grade for the temperature conditions (refer to *ENGINE SET-UP*).

⚠ WARNING *Hot crankcase oil can cause burns if it comes in contact with skin. Wear protective clothing and keep fingers and hands clear when draining oil.*

Oil level should be to the FULL mark of the dipstick. Start engine and run for a short time to check for oil leaks around the drain plug.

OIL FILTER CHANGE

Refer to the *Periodic Maintenance Schedule* for oil filter change intervals.

Spin off oil filter element and discard it. Thoroughly clean filter mounting surface and make sure new gasket is inserted in the element. Apply a thin film of oil to the gasket. Spin element down by hand until gasket just touches mounting pad and then turn down an additional 1/2-3/4 turn. Do not overtighten.

With oil in crankcase, start engine and check for leaks around filter element. Retighten only as much as necessary to eliminate leaks, but do not overtighten.

C-1000

IGNITION

Spark Plugs

Refer to *Periodic Maintenance Schedule* for spark plug service interval. Replace spark plugs that show signs of fouling or electrode erosion. Refer to *Specifications* for spark plug gap.

Solid State Ignition

Ignition timing is set at the factory and is not adjustable. The solid state ignition components are not adjustable and require no routine maintenance.

COOLING SYSTEM

Refer to *Periodic Maintenance Schedule* for cooling system service interval. Clean cooling fins and chaff screen sooner if required. Remove any dust, dirt or oil which may have accumulated.

BATTERY

Disconnect negative ground strap from the battery before working on any part of the electrical system or engine.

Disconnect positive terminals before charging battery to avoid damaging ignition system alternator or regulator.

▲WARNING *Ignition of explosive battery gases can result in severe personal injury. Do not smoke or allow any ignition source near the battery.*

Cleaning Battery

Keep the batteries clean by wiping it with a damp cloth whenever dirt appears excessive.

If corrosion is present around the terminal connections, remove battery cables and wash the terminals with an ammonia solution or a solution consisting of 1/4 pound of baking soda added to 1 quart of water.

Be sure the vent plugs are tight to prevent cleaning solution from entering the cells.

After cleaning, flush the outside of the battery, the battery compartment, and surrounding areas with clear water.

Keep the battery terminals clean and tight. After making connections, coat the terminals with a light application of petroleum jelly or non-conductive grease to retard corrosion.

Checking Specific Gravity

Use a battery hydrometer to check the specific gravity of the electrolyte in each battery cell.

Hold the hydrometer vertical and take the reading. Correct the reading by adding four gravity points (0.004) for every five degrees the electrolyte temperature is above 80° F (27° C) or subtracting four gravity points for every five degrees below 80° F (27° C). A fully charged battery will have a corrected specific gravity of 1.260. Charge the battery if the reading is below 1.215.

Checking Electrolyte Level

Refer to *Periodic Maintenance Schedule* for checking electrolyte level interval.

Fill the battery cells to the bottom of the filler neck. If cells are low on water, add distilled water and recharge. If one cell is low, check case for leaks. Keep the battery case clean and dry. An accumulation of moisture will lead to a more rapid discharge and battery failure.

▲CAUTION *Water added to battery electrolyte in freezing weather can damage the battery. Do not add water to battery unless the engine is run long enough (two or three hours) to ensure a thorough mixing of water and electrolyte.*

Storing Battery

If the engine is to be stored for more than 30 days, remove the battery. With the electrolyte level at the bottom of the split ring, charge the battery before storing it. After every 30 days the battery is in storage, bring it back up to full charge. To reduce self-discharge, store the battery in as cool a place as possible so long as the electrolyte does not freeze.

CRANKCASE BREATHER

The crankcase breather does not require servicing. Replace breather if it's broken or cracked or if crankcase becomes pressurized as evidenced by oil leaks at the seals or excessive oil in the air cleaner housing.

EXHAUST SYSTEM

Make regular visual and audible inspections of the exhaust system throughout the entire life of the engine. Locate leaks in muffler and piping while the engine is operating. Repair all leaks immediately after they are detected for personal safety.

WARNING Breathing exhaust gases can result in severe personal injury or death. Inspect exhaust system audibly and visually for leaks daily and repair leaks immediately.

AIR CLEANER

Air Cleaner Element

Refer to *Periodic Maintenance Schedule* for air cleaner service and replacement interval. Service or replace more often when operating under severe operating conditions. Service by gently tapping element on a flat surface.

Element Wrapper (Pre-Cleaner)

Refer to *Periodic Maintenance Schedule* for element wrapper service interval. Wash in water and detergent and squeeze dry like a sponge. Rinse with water (Figure 2). Allow to dry, then coat evenly with two tablespoons (28 grams) of SAE 30 engine oil. Knead into and wring out excess oil from element wrapper. Failure to adequately wring out excess oil from the wrapper may cause drop in engine horsepower due to an increased restriction of inlet air. Install over air cleaner element.

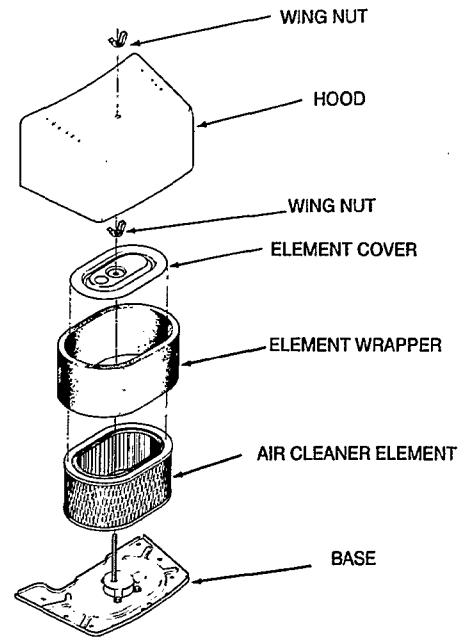

XFS-1773



FIGURE 2. AIR CLEANER ASSEMBLY

PERIODIC MAINTENANCE SCHEDULE

Follow a regular schedule of inspection and servicing, based on operating hours. Keep an accurate logbook of maintenance, servicing, and operating time. Use the factory recommended Periodic Maintenance Schedule (based on favorable operating conditions) to serve as a guide to get long and efficient engine life. Regular

service periods are recommended for normal service and operating conditions. For severe duty, extreme temperature, etc., service more frequently. Neglecting routine maintenance can result in engine failure or permanent damage.

For any abnormalities in operation, unusual noises from the engine or accessories, loss of power, overheating, etc., contact your nearest Onan Service Center.

PERIODIC MAINTENANCE SCHEDULE

SERVICE THESE ITEMS	AFTER EACH CYCLE OF INDICATED HOURS						
	8	25	50	100	200	500	1000
Inspect Engine Generally	X ¹						
Check Oil Level	X						
Service Air Cleaner Element and Element Wrapper		X ²					
Change Crankcase Oil (all engines without filter)		X ²					
Change Crankcase Oil (standard base with filter)		X ³	X ²				
Replace Oil Filter		X ³		X ²			
Check Battery Electrolyte Level			X				
Clean Cooling Fins			X ²				
Replace Air Cleaner Element					X ²		
Replace Fuel Filter					X		
Check Valve Clearance					X ⁴		
Check or Replace Spark Plugs						X	
Clean Carbon and Lead Deposits (cylinder head)							X ⁵

1 - Check for fuel leaks. With engine running, visually and audibly check exhaust system for leaks.

2 - Perform more often when running under severe operating conditions.

3 - Required for initial break-in only.

4 - For detailed maintenance, contact an Onan Service Center or refer to the SERVICE MANUAL.

5 - Clean carbon more frequently when running under continuous light load and/or on leaded fuel. Use of Onan 4C carburetor and combustion cleaner is recommended every 200 hours to help reduce carbon buildup.

ENGINE MAINTENANCE PARTS	
Item	Part Number
Oil Filter	122-0645
Fuel Filter	149-2206-01
Air Cleaner Element	140-2199
Air Cleaner Element Wrapper	140-2255
Spark Plugs	167-0763-01
Touch-Up Paint (Black)	525-0394
Service Manual	965-0763
Parts Manual	965-0265



WARNING Breathing exhaust gases can result in severe personal injury or death. Do not use air cleaner, exhaust elbow, or connecting parts as a supporting step. Damage to these and connecting parts can cause an exhaust leak.

Adjustments

CARBURETOR AND GOVERNOR

Carburetor mixture adjustments are set for maximum efficiency at the factory. Idle fuel adjustment is restricted to 1/4 of a turn by a limiting cap. There is no main fuel adjustment screw.

1. Start the engine and allow it to warm up thoroughly (at least 10 minutes).

Some equipment manufacturers may require higher throttle stop speed and governor low speed rpm settings. Refer to equipment manufacturer's Operator's Manual for the correct rpm settings. When rpm settings are not specified by the equipment manufacturer use the rpm settings listed in Steps 2 through 4.

2. Move the engine speed control to the slow position. Bend or turn the low speed stop on the governor so the throttle stop screw on the carburetor controls engine speed. Adjust the throttle stop screw for 1000 rpm idle (Figure 4).
3. Adjust the governor low speed stop for 1100 rpm idle (Figure 3).
4. Move the engine speed control to the fast position. Bend the high speed stop on the governor so the engine runs at the equipment manufacturer's recommended speed (Figure 3).

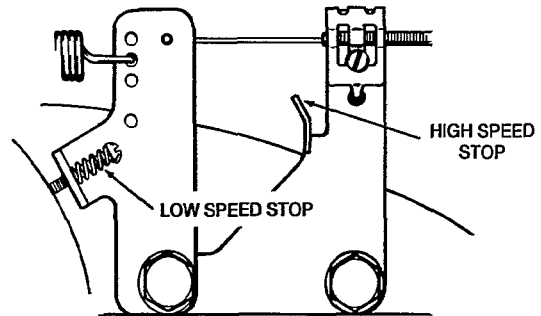

FS-1000

FIGURE 3. GOVERNOR SPEED ADJUSTMENT

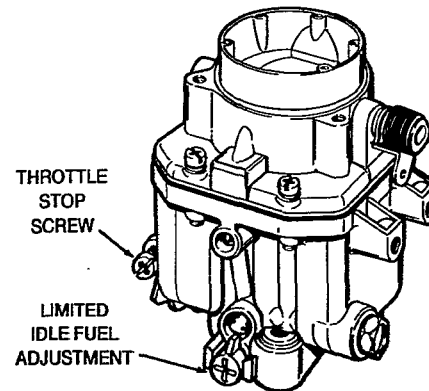

FS-1406-2

FIGURE 4. CARBURETOR ADJUSTMENTS



Onan Corporation
1400 73rd Avenue N.E.
Minneapolis, MN 55432
1-800-888-ONAN
612-574-5000 International Use
Telex: 275477
Fax: 612-574-8087

Onan is a registered trademark of Onan Corporation