



Owner Manual

Cummins **Onan**

Performance you rely on.™



RV Automatic Generator Controller

Energy Command 30W
(EC-30W)

THIS PAGE LEFT INTENTIONALLY BLANK

Table of Contents

SECTION	PAGE
SAFETY PRECAUTIONS	iii
1. INTRODUCTION	1-1
About this manual	1-1
Product Overview	1-1
EC-30W Kit Contents	1-1
How To Obtain Service	1-1
Warranty Policy	1-1
2. QUICK REFERENCE	2-1
3. OPERATION	3-1
General Overview	3-1
Manual Genset Operation	3-1
Default Display	3-1
Using the Keys	3-2
Automatic Genset Operation	3-2
Using Displays	3-3
Power Supply	3-3
4. INSTALLATION	4-1
General	4-1
Installation Codes and Standards for Safety	4-2
Installation Procedures	4-2
Connections (Definitions)	4-5
Final Connections and Testing	4-5
AGS Warning Labels	4-6

5. SETUP & TEST	5-1
General	5-1
Main Menu	5-1
Setup & Information Displays	5-2
System Information Menu	5-2
System Setup Menu	5-3
Auto Start Setup Display	5-5
6. GENERAL TROUBLESHOOTING	6-1
Troubleshooting	6-1
APPENDIX A. OUTLINE AND SYSTEM DRAWINGS	A-1
EC-30W MAIN MENU DISPLAY DIAGRAM	A-2
EC-30W SETUP AND INFORMATION MENU DIAGRAM	A-3
EC-30W SYSTEM BLOCK DIAGRAM	A-4
APPENDIX B. EC-30W REFERENCES	B-1



SAFETY PRECAUTIONS

Thoroughly read this Owner Manual before operating the EC-30W and generator set. Safe operation and top performance can only be obtained when equipment is properly operated and maintained.

The following symbols in this manual alert you to potential hazards to the operator, service person and equipment.

⚠ DANGER alerts you to an immediate hazard that will result in severe personal injury or death.

⚠ WARNING alerts you to a hazard or unsafe practice that can result in severe personal injury or death.

⚠ CAUTION alerts you to a hazard or unsafe practice that can result in personal injury or equipment damage.

Exhaust, electricity, fuel, moving parts and batteries present hazards which can result in severe personal injury or death.

ENGINE EXHAUST IS DEADLY

- Inspect for exhaust leaks at every startup and after every eight hours of running.
- Learn the symptoms of carbon monoxide poisoning in the generator set Operator's Manual.
- Never sleep in the vehicle while the generator set is running unless the vehicle is equipped with a working carbon monoxide detector.
- Do not operate the generator set when the vehicle is parked in a confined space, such as a garage.
- The exhaust system must be installed in accordance with the generator set Installation Manual.

- Engine cooling air must not be used for heating the vehicle.

GENERATOR VOLTAGE IS DEADLY

- Generator electrical output connections must be made by a trained and experienced electrician in accordance with applicable codes.
- The generator set must not be connected to shore power (utility). Back-feed to shore power can cause electrocution and damage to equipment. An approved switching device must be used to prevent interconnections.
- Use caution when working on live electrical equipment. Remove jewelry, make sure clothing and shoes are dry, stand on a dry wooden platform or rubber insulating mat and use tools with insulated handles.

DIESEL, GASOLINE, AND PROPANE FUEL IS COMBUSTIBLE

- Do not smoke or turn electrical switches ON or OFF where fuel fumes are present or in areas sharing ventilation with fuel tanks or equipment. Keep flames, sparks, pilot lights, arc-producing equipment and all other sources of ignition well away.
- Fuel lines must be secured, free of leaks and separated or shielded from electrical wiring.

MOVING PARTS CAN CAUSE SEVERE PERSONAL INJURY OR DEATH

- Do not wear loose clothing or jewelry near moving parts such as fans and other moving parts.
- Keep hands away from moving parts.
- Keep guards in place over fans and other moving parts.

BATTERY GAS IS EXPLOSIVE

- Wear safety glasses.
- Do not smoke.
- To reduce arcing when disconnecting or reconnecting battery cables, always disconnect the negative (-) battery cable first and reconnect it last.

FLAMMABLE VAPORS CAN BE IGNITED BY OPERATION OF COACH ELECTRICAL SYSTEMS AND CAUSE DIESEL ENGINES TO OVERSPEED

- Stop the generator set before fueling the coach to reduce the risk of igniting flammable vapors.
- Do not operate the diesel-powered generator set where there are or can be flammable vapors created by fuel spills, gas leaks, etc. Flammable vapors drawn into a diesel engine air intake system can cause the engine to overspeed, which can result in fire, explosion and equipment damage. The owners and operators of the generator set are solely responsible for safe operation.

GENERAL PRECAUTIONS

- Keep children away from the generator set.
- Do not use evaporative starting fluids. They are highly explosive.
- To prevent accidental or remote starting while working on the generator set, press the Stop button and disconnect the battery cables at the

batteries to prevent starting during maintenance and service. (Always disconnect negative [-] first and reconnect last to prevent sparks between tools and vehicle frame.)

- Keep the generator set and its compartment clean. Excess oil and oily rags can catch fire. Dirt and gear stowed in the compartment can restrict cooling air.
- Make sure all fasteners are secure and torqued properly.
- Do not work on the generator set when mentally or physically fatigued or after consuming alcohol or drugs.
- You must be trained and experienced to make adjustments while the generator set is running—hot, moving or electrically live parts can cause severe personal injury or death.
- Used engine oil has been identified by some U. S. state and federal agencies as causing cancer or reproductive toxicity. Do not ingest, inhale, or contact used oil or its vapors.
- Keep multi-class ABC fire extinguishers readily at hand. Class A fires involve ordinary combustible materials such as wood and cloth. Class B fires involve combustible and flammable liquids and gaseous fuels. Class C fires involve live electrical equipment. See NFPA No. 10 (Portable Fire Extinguishers) or equivalent—BS EN 3-7:2004.
- Generator set installation and operation must comply with all applicable local, state and federal codes and regulations.



1. Introduction

ABOUT THIS MANUAL

This manual provides the operation and installation instructions for the EC-30W (Energy Command 30 Wireless). This system is compatible with Cummins Onan Recreational Vehicle gensets (Quiet Diesel generator sets, gasoline/ liquid propane generator sets). This manual does not have instructions for servicing printed circuit board assemblies. Generator set service instructions are in the applicable genset operation, service, and installation manuals.

Read the **Safety Precautions** thoroughly and observe all instructions and precautions in this manual.

This manual contains basic wiring diagrams for the EC-30W and its connection to the accompanying genset.

Keep this manual with other genset manuals.

PRODUCT OVERVIEW

The EC-30W is an AGS (Automatic Generator Starting System) that provides wireless, automatic, and manual control of Cummins Onan Diesel, Gas, and LP (Liquid Propane) engine-driven AC gensets. The EC-30W automatically starts the genset when the battery becomes discharged or when temperatures exceed user settings. When the battery is charged, or the temperature sensor indicates the HVAC (Heating, Ventilating, and Air Conditioning) system no longer requires power, the EC-30W will automatically turn off the genset.

EC-30W KIT CONTENTS

The following are the EC-30W kit contents:

- EC-30W display and cradle
- EC-30W genset module
- Nickel metal hydride rechargeable battery
- Rechargeable battery charger (5V DC Power Supply)
- AGS Warning Labels

HOW TO OBTAIN SERVICE

If service, parts, or product literature is required, contact the nearest Cummins Onan dealer or distributor. In the US or Canada, call 1-800-888-ONAN for name and telephone. By calling this number, you may also request a directory of authorized RV servicing dealers:

RV Sales and Service Directory: F-919.

Before calling for service, have the following information available:

1. Complete model number and serial number of product
2. Software version number, as shown in the SYSTEM INFORMATION displays
3. Date of purchase

⚠WARNING *Incorrect service or replacement of parts can result in severe personal injury or death, and/or equipment damage. Service personnel must be qualified to perform electrical and mechanical service. Read and follow Safety Precautions on page ii and throughout the manual.*

WARRANTY POLICY

For complete Cummins Onan Limited Warranty details, contact your Cummins Onan RV Service and Parts dealer or call 1-800-888-ONAN (6626).



THIS PAGE LEFT INTENTIONALLY BLANK



2. Quick Reference

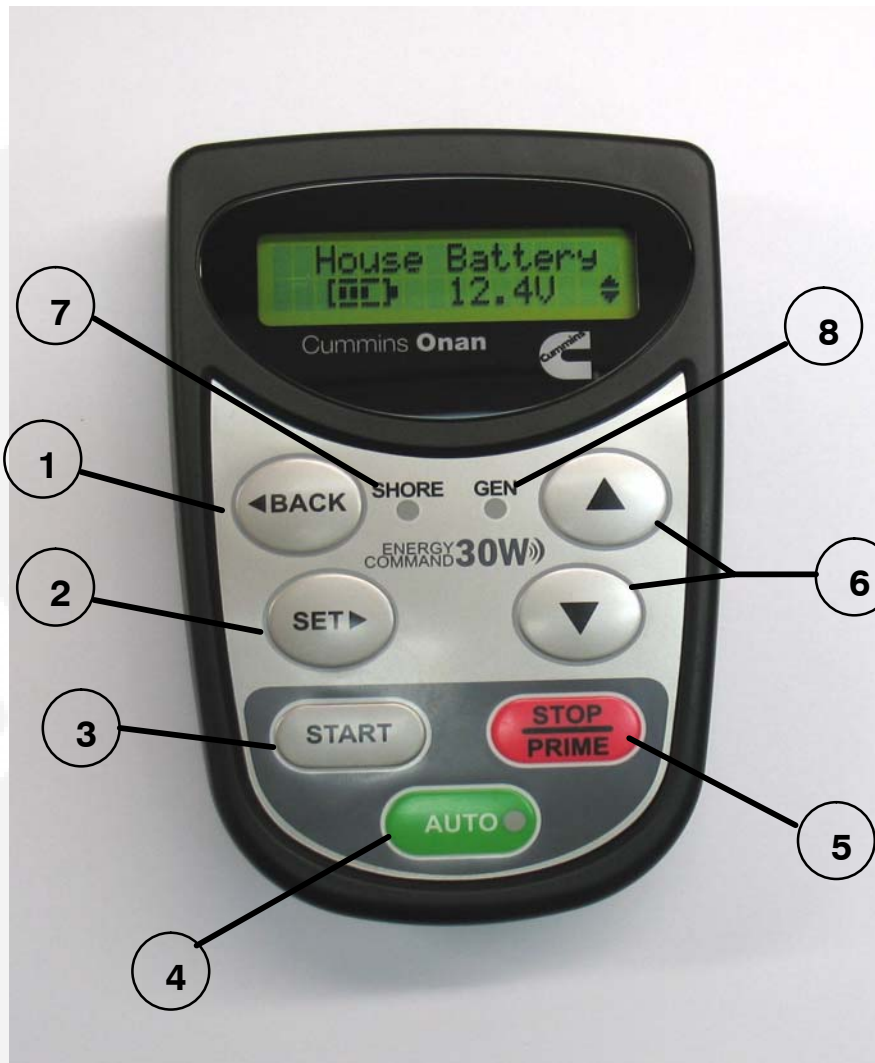

NO.	ITEM NAME	ITEM DESCRIPTION
1	BACK BUTTON	This key is used to return to previous screen.
2	SET BUTTON	This key is used as the forward key to navigate through the menu and to display and change settable values, such as: Local Time, Quiet Time Start and End (QT Start and QT End).
3	START BUTTON	Works similar to the genset start/stop switch.
4	AUTO BUTTON	This key enables/disables automatic genset operating mode. LED indicates if AGS is enabled.
5	STOP/PRIME BUTTON	Works similar to the genset start/stop switch.
6	UP/DOWN BUTTON	This key is used to scroll through display choices and change values that can be set.

7	SHORE LED LIGHT	Light on if shore power present
8	GEN LED LIGHT	Status light powers on when genset is running, flashes during cranking, pre-heating and genset fault messages. This light works similar to the genset status light.

FIGURE 2-1. EC-30W DISPLAY

Note: Start requires two keystrokes. First press **SET▶**:



...is displayed. Press **SET▶** once again to start.

Note: AUTO requires two keystrokes. First press **AUTO** :



OR



...is displayed. Next press **SET▶** to enable or disable AUTO mode.

Do not start genset or select AUTO mode before reading and understanding this manual and without following its Safety Precautions!



3. Operation

GENERAL OVERVIEW

This section describes how to use the EC-30W. Ensure all safety precautions and items have been read before operating this product.

⚠ CAUTION *BEFORE SERVICING, ALWAYS DISABLE AGS BY DISCONNECTING BATTERY OR GENSET REMOTE HARNESS.*

⚠ WARNING *Improper Service or replacement of parts can result in severe personal injury, death, and/or equipment damage. Service personnel must be experienced to perform electrical and/or mechanical service.*

⚠ WARNING *Severe personal injury, death, and equipment damage can result from operating the genset in a garage, building, or confined space. The genset produces dangerous fumes when it is running. Never start the genset when the recreational vehicle is in a garage, building, or confined space.*

⚠ WARNING *ENGINE EXHAUST GASES CAN BE DEADLY. Verify carbon monoxide alarm is installed and functional in your vehicle before starting generator or enabling AGS. All engine exhaust contains carbon monoxide; an odorless, colorless gas that can cause severe personal injury or death. Symptoms of carbon monoxide poisoning include:*

- Dizziness
- Headache or Throbbing Temples
- Weakness or Muscular Twitching
- Sleepiness or Confusion
- Nausea or Vomiting

IF YOU EXPERIENCE ANY OF THESE SYMPTOMS, GET INTO FRESH AIR IMMEDIATELY. If symptoms persist, seek medical attention. Shut down the genset and do not operate until inspected and repaired.

If other AGS systems are present, disconnect the systems before installing the EC-30W.

MANUAL GENSET OPERATION

START & STOP/PRIME Buttons

The EC-30W START & STOP/PRIME buttons are used to manually start and stop the genset.

Holding the STOP button for 3 seconds when the EC-30W set is not running will activate PRIME. The genset START/STOP buttons will act identically to the remote status rocker switch except that the user does not need to hold the START button until the set is running to start the genset.

When the EC-30W START or STOP switch is operated, the EC-30W AGS operating mode is disabled.

The genset may be started using the remote START/STOP switch even if there is no power to the EC-30W. Once the genset is running, the EC-30W display will turn on if charger is plugged in to the display.

DEFAULT DISPLAY

Low Power Mode

The display module's default state will be low power mode to conserve battery power.

During low power mode, the display will turn off. Low power will resume 2 minutes after last key-press. In this mode, the wireless display will go into a cyclic sleep mode: waking once every minute to send data to the genset module and to receive status from the genset module, followed by resumed sleep.

The display will turn on after any key is pressed on the interface.

USING THE KEYS

UP/DOWN Key

UP/DOWN key is used to navigate through the display menu and to change values or parameters that can be set by the user. If the **UP/DOWN** key is pressed and held down, the display will scroll through the values.

SET Key

SET is used for forward navigation and to select values that can be changed by the user. Examples include: Local Time, start of Quiet Time, and end of Quiet Time. Pressing the SET key will cause the value to flash (if it can be changed).

BACK Key

BACK is used to return to previous menu screen.

AUTOMATIC GENSET OPERATION

Safety Features

The EC-30W has safety features to help prevent automatic operation when it may be unsafe. Each time the vehicle is moved, the AGS operating mode is disabled. Only if the vehicle is in a safe location should the AGS function be enabled.

⚠ WARNING *DO NOT RUN THE GENSET OR ENABLE THE EC-30W AGS MODE WHEN THE RV IS INDOORS OR IN A CONFINED SPACE. ASPHYXIATION OR CARBON MONOXIDE POISONING HAZARDS EXIST WHEREVER GENSET EXHAUST GASSES CAN ACCUMULATE.*

⚠ WARNING *THIS GENSET/CONTROL IS NOT A LIFE SUPPORT SYSTEM. IT CAN STOP WITHOUT WARNING. CHILDREN, PERSONS WITH PHYSICAL OR MENTAL LIMITATIONS, AND PETS COULD SUFFER PERSONAL PERSONAL INJURY OR DEATH. A PERSONAL ATTENDANT, REDUNDANT POWER OR ALARM SYSTEM MUST BE USED IF GENSET OPERATION IS CRITICAL.*

The EC-30W safety feature has a built in Accelerometer. It is a sensor in the genset module that

measures motion (acceleration) to detect if the coach may have been moved to an enclosed location where there is a danger of CO poisoning and accumulation.

When the motion is detected, the EC-30W disables the AGS. This prevents unexpected automatic starting indoors or in confined spaces. Verify the vehicle is parked in a safe location, and then use the AUTO key, followed by SET▶ to enable the AGS.

Note: In order to enable or disable the EC-30W AUTO START (AGS) mode, there is a confirming key-stroke required (AUTO key then SET▶ to confirm). This reduces risk of unintended auto operation.

Verify Safety Input

Accelerometer: The sensor in the genset module that measures motion (acceleration) to detect if the coach may have been moved to an enclosed location where there is a danger of CO poisoning and accumulation.

Motion Verification

The EC-30W maintains a record of the last motion. If the EC-30W does not see any motion in 30 days, it will disable the AGS and prompt the user to re-verify the motion by walking on the coach, driving the coach, manually starting the generator, or tapping on the genset module.

Note: During verification, if at least one of the values is not 0 (zero) in the motion data screen, motion is successfully verified and 30-day timer is reset.

Crank/Startup

To start, Gas/LP gensets take up to typically 18 seconds of cranking while Diesel gensets take 30 seconds of cranking. If genset does not start on the first time, EC-30W waits 30 seconds before re-crank.

Maximum crank attempts for all gensets: 3.

⚠ CAUTION *Care should be taken while changing the settings. These settings should only be changed by qualified personnel that understand the charging system and have checked its operating voltages.*

Adaptive Cycle Management

Limiting Short Cycling

When in the automatic mode, the EC-30W observes a minimum run-time of 10 minutes, even if the automatic run request has been satisfied. For example, suppose the HVAC (air conditioner) only needs to run for 6 minutes to cool the coach enough to satisfy the temperature sensor threshold. The genset will still continue to run for a minimum of 10 minutes before stopping.

If a new run request is detected, during the minimum run, the Adaptive Cycle Management feature will limit short cycling by extending the run time as required.

Quiet Time Prefill

Two hours prior to the beginning of Quiet Time the EC-30W checks the battery level, and if the batteries are not full, the EC-30W will start the genset to charge the batteries.

Preventing Automatic Starting When Connected to Shore AC

The EC-30W has an input to prevent the genset from automatically starting when connected to shore power. For this feature to be active, the cord supplied must be plugged into a non-inverter powered outlet. The Installation section of this manual describes how this feature is installed.

USING DISPLAYS

⚠WARNING *To satisfy FCC RF exposure requirements for mobile transmitting devices, a separation distance of 20 cm or more should be maintained between the antenna of this device and persons during device operation. To ensure compliance, operations at closer than this distance is not recommended. The antenna used for this transmitter must not be co-located in conjunction with any other antenna or transmitter.*

The display is used to show key system information.

Arrows in Display Screens

Only if ▲ (up) arrow is present, there is/are additional menu screen(s) above current screen.

If ▼ (down) arrow is present, there is/are additional menu screen(s) below current screen.

If ◀ (left) arrow is present, but not the ▶ (right) arrow, there is not a following screen.

If ▶ (right) arrow is present on the screen, there is a proceeding menu screen.

“Service In” & “Gen Hrs” Display

The “Service In” line is a countdown service hour meter that indicates the genset’s next required service interval. The genset hour-meter displays the total elapsed time the genset has run since the EC-30W was installed.

If the EC-30W is installed on an existing genset, see the SETUP section of this manual. To determine specific service items, see the genset manual.

When the service interval has elapsed, the display will show:



SERVICE DUE

The SERVICE DUE message is displayed as soon as the service interval has elapsed.

The EC-30W calculates the service hours based on the genset type, genset hour-meter, and last time service hours were set. Verify that the genset type and genset hours are set correctly. Remember to reset service in hours after genset is serviced.

After the genset is serviced, navigate to the “Service In”/“Gen Hrs” display, press SET▶ to reset Service Interval. Press SET▶ again to reset the service interval hour-meter.

POWER SUPPLY

EC-30W Genset Module

This unit operates with input voltage between 7-17VDC (12VDC nominal battery).

Note: The purple wire is positive and needs to be connected to the House Battery for low battery AGS operation to work properly.

EC-30W Display

The display comes with a Nickel Metal Hydride battery that is rechargeable (takes approximately 3

hours to fully charge). After charging the battery to full, the battery can power the display 2-7 days depending on battery age and display usage.

The rechargeable battery loses its energy during storage, even without loading. As the battery loses energy during storage, the voltage also drops. In general, the battery capacity loss due to self-discharge during storage can be recovered by recharging. If the battery is stored for over six months it is advised that the battery be cycled several times to resume the battery capacity.

Regular AA batteries can also be used to power the display.

House Battery Charge Level Indicator

The house battery charge level indicator uses both short- and long-term voltage trends to determine the battery level. It is intended as a guide to the SOC (state of charge) of the battery and its ability to sustain the load.

When the EC-30W is in the automatic mode, it also serves as the default trigger points for starting and stopping the genset to charge a low battery. The

genset is started when the bar graph only shows two segment and stopped when four bars are displayed.

House Battery Voltage

The house battery voltage can be used to assess the performance of the charging system and to estimate the battery SOC.

To estimate battery SOC, no loads should be on and the battery should not be charging. The battery should have “rested” in this state for 24 hours. If the battery rests for only 30 minutes, the SOC estimate will be less accurate.

TABLE 3-1. OPEN CIRCUIT VOLTAGE VS. SOC 12 VOLT BATTERIES OF VARIOUS TYPES

STATE OF CHARGE	BATTERY ELECTROLYTE TYPE		
	LIQUID	AGM	GELLED
100%	12.6	12.9	12.8
75%	12.4	12.7	12.6
50%	12.2	12.4	12.3
25%	12.0	12.0	12.0
0%	11.8	11.8	11.8



4. Installation

GENERAL

This section describes how to install the EC-30W.

This system is only for use with Cummins Onan Recreational Vehicle genset (Quiet Diesel, Gasoline and LP gensets).

The control circuitry is a 3-wire ground to start/stop type. Consult a Cummins Onan distributor with any questions.

The Appendices show the Cummins Onan gensets that are compatible with the EC-30W and the correct wiring figures and harnesses to use for each genset.

⚠WARNING *Improper Service or replacement of parts can result in severe personal injury, death, and/or equipment damage. Service personnel must be trained and experienced to perform electrical and/or mechanical service.*

⚠CAUTION *Always disconnect a battery charger from its AC source before disconnecting the battery cables. Otherwise, disconnecting the cables can result in voltage spikes high enough to damage the DC control circuits of the genset.*

⚠WARNING *Unexpected starting of the genset while working on it can cause severe personal injury or death. Prevent unexpected or accidental starting by disconnecting the genset battery cables [negative (-) first], or by disconnecting the remote harness at the genset.*

⚠WARNING *Arcing can ignite explosive hydrogen gas given off by batteries, causing severe personal injury. Arcing can occur if the negative*

(-) battery cable is connected and a tool being used to connect or disconnect the positive (+) battery cable accidentally touches the frame or other grounded metal part of the genset set or vehicle frame. To prevent arcing, ALWAYS remove the negative (-) cable first, and reconnect it last.

TABLE 4-1. SPECIFICATIONS

	Display	Genset Module
Operating Temperature:	-4F to 122F (-20C to 50C)	-4F to 158F (-20C to 70C)
Storage Temperature:	-22F to 176F (-30C to 80C) excluding battery	-40F to 176F (-40C to 80C)
Battery Life:	2-7 days between charge cycle	
Nominal Current Draw	--	50mA (at 12 Vdc)
Operating Voltage Range:	2-5 Vdc	7-17VDC
Protection:	Reverse polarity protected, short circuit protected	
Operating Frequency Band:	ISM 2.4 GHz	
Communication Range:	150 ft. Max	

INSTALLATION CODES AND STANDARDS FOR SAFETY

EC-30W is suitable for installation in accordance with:

- ANSI A 1192 (NFPA No. 1192)–Standard on Recreational Vehicles
- CAN/CSA–Z240.6.2 Recreational Vehicles
- FCC15
- RoHS Compliant

Federal, State and local codes, such as the California Administrative Code—Title 25 (RV installation), might also be applicable. Installation codes and recommendations can change from time-to-time and are different in different countries, states and municipalities. Obtain the standards in Table 4-2 for reference.

TABLE 4-2. REFERENCE CODES AND STANDARDS

NFPA No. 70 NFPA NO. 501C	National Fire Protection Association 470 Atlantic Avenue Boston, MA 02210
ANSI A119.2 ANSI/RVIA-EGS-1 FMVSS 301	Recreational Vehicle Industry Association 14650 Lee Road Chantilly, VA 22021
California Administrative Code—Title 25, Chapter 3	State of California Documents Section P.O. Box 1015 North Highlands, CA 95660
CAN/CSA-Z240 Recreational Vehicles Bulletin 946	Canadian Standards Association Housing and Construction Materials Section 178 Rexdale Blvd. Rexdale, Ontario, Canada M9W 1R3

INSTALLATION PROCEDURES

Mounting EC-30W Display

CAUTION *Do not mount display in direct sunlight or near heat source or cold air. Doing so will incur equipment damage and inappropriate AGS operation.*

1. Disconnect the negative (–) cable from the battery terminal to prevent accidental starting.
2. Select a location in RV for the display. Location should be in a visible location **near a non-inverter outlet for shore power detection** and where operation will be convenient.

CAUTION *Check the backside (inside) of the chosen location to verify that nothing will interfere with drilling, or with the fasteners or harness plug of the EC-30W.*

CAUTION *Wires must be protected from all hot, sharp, and abrasive surfaces. Use protective sheathing where necessary to protect the wires from sharp edges.*

CAUTION *The display cradle should be mounted in a protected environment, away from excessive heat and cold.*

3. Attach the display cradle to a smooth and dry surface using the included double-stick tape or drill holes into location of where display cradle will be set.

Mount the display cradle near a non-inverter powered outlet, as permitted by the length of the charger cord.

CAUTION *Ensure you do not drill into other electrical components.*

4. Apply adhesive tape to clean and dry surfaces >50 degrees F only. Adhesive bond will reach 75% maximum adhesion strength in 1 hour, 100% in 72 hours.

Note: For maximum hold, allow the tape to cure at least one hour before subjecting to any level of vibration. Not doing so will cause cradle and display to fall, resulting in possible damage.

5. Install the battery pack into the back of the display.
6. Put display in cradle and plug in supplied display battery charger provided.

Genset Module Installation

⚠ CAUTION Always disconnect a battery charger from its AC source before disconnecting the battery cables. Otherwise, disconnecting the cables can result in voltage spikes high enough to damage the DC control circuits of the genset.

⚠ WARNING Exhaust gases are hazardous and may cause severe personal injury or death. Seal all holes to prevent the entrance of exhaust gasses into the vehicle interior.

1. Turn off genset and disconnect battery cables/power to prevent accidental starting.

⚠ CAUTION Check the backside (inside) of the chosen location to verify that nothing will interfere with drilling, or with the fasteners or harness plug of the EC-30W.

⚠ CAUTION Wires must be protected from all hot, sharp, and abrasive surfaces. Use protective sheathing where necessary to protect the wires from sharp edges.

2. Find proper location to mount module. Ensure there will be no obstructions for installation, operation, and future handling.

⚠ CAUTION DO NOT MOUNT MODULE ON TO GENSET! DOING SO WILL INCUR EQUIPMENT DAMAGE AND INAPPROPRIATE AGS OPERATION.

3. Mount the genset module near the genset, as permitted by the genset module wiring harness.

⚠ CAUTION The genset module should be mounted in a protected environment, away from excessive heat and cold, excessive road spray, water, and heat sources.

4. Either drill holes as shown in Figure 4-1 or else attach the genset module to a smooth and dry surface using the included double-stick tape.

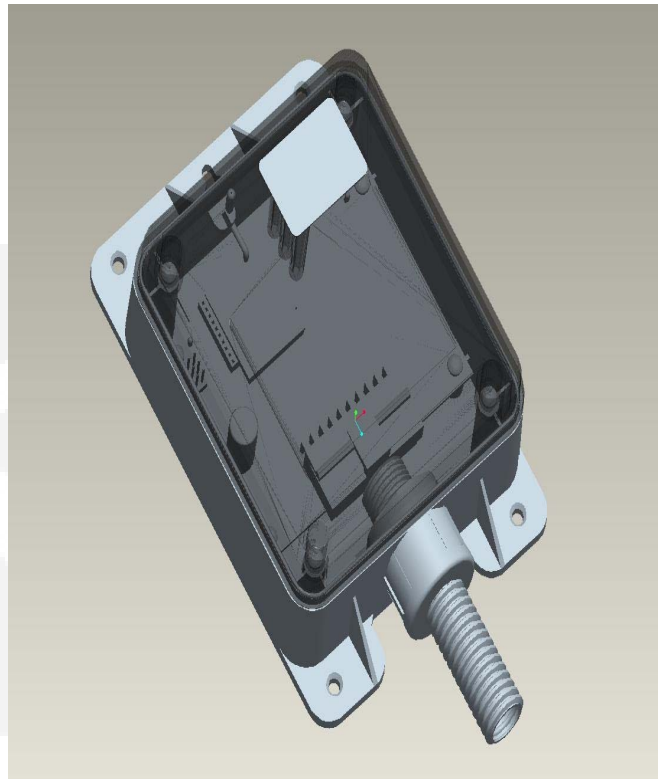

FIGURE 4-1. GENSET MODULE (INTERIOR)

⚠ CAUTION Ensure you do not drill into other electrical components.

5. Apply adhesive tape to clean and dry surfaces >50°F only. Adhesive bond will reach 75% maximum adhesion strength in 1 hour, 100% in 72 hours.

Note: For maximum hold, allow the tape to cure at least one hour before subjecting to any level of vibration. Not doing so will cause cradle and display to fall, resulting in possible damage.

6. For installations that do not require a Y-adapt-er harness, plug the control harness J8 connector directly into the remote harness connector on the genset.
7. For installations on **gas gensets** that require a Y-adapt-er harness, install the harness.
 - A. Unplug the harness connected to the remote harness connector on the genset.
 - B. Install the Y-adapt-er harness, as shown in Figure 4-2 or Figure 4-3.

8. For **all gasoline gensets except KV**, install the control harness BATT+ terminal ring (purple wire) on the B+ terminal on the start solenoid relay (see Figure 4-2).

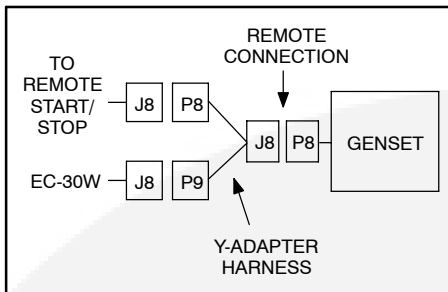

FIGURE 4-2. Y-ADAPTER HARNESS BLOCK DIAGRAM FOR KV GAS GENSETS

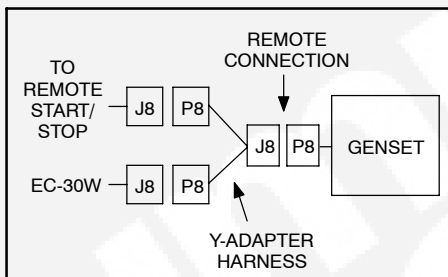

FIGURE 4-3. Y-ADAPTER HARNESS BLOCK DIAGRAM FOR OTHER GAS GENSETS

9. For **KV gensets**, connect the control harness BATT+ terminal ring and the battery positive (+) cable to the wiring harness B+ connection.

- A. Tighten the B+ connection securely and cover the connection with the terminal boot to insulate it.
- B. Wire-tie the terminal boot in place to prevent boot movement.
- C. Connect the remote control harness connector to the mating connector on the left side of the genset.

10. For installations on **diesel gensets**, install the Y-adapter harness.

- A. If a harness is already connected to the remote harness connector on the genset, unplug it.
- B. Install the Y-adapter harness, as shown in Figure 4-4.

- C. Extend the battery connection wire using the included extension wire.

- D. Install the control harness BATT+ terminal ring (purple wire) on the B+ terminal post on the genset (see Figure 4-5).

- E. If present, plug the connector unplugged in step 5A into the Y-adapter harness P8 connector.

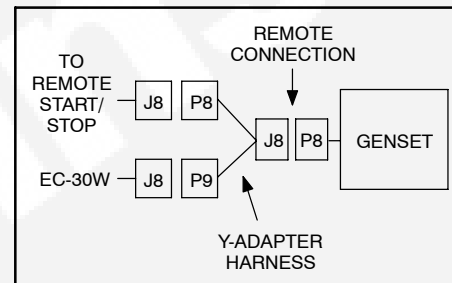

FIGURE 4-4. Y-ADAPTER HARNESS BLOCK DIAGRAM FOR DIESEL GENSETS

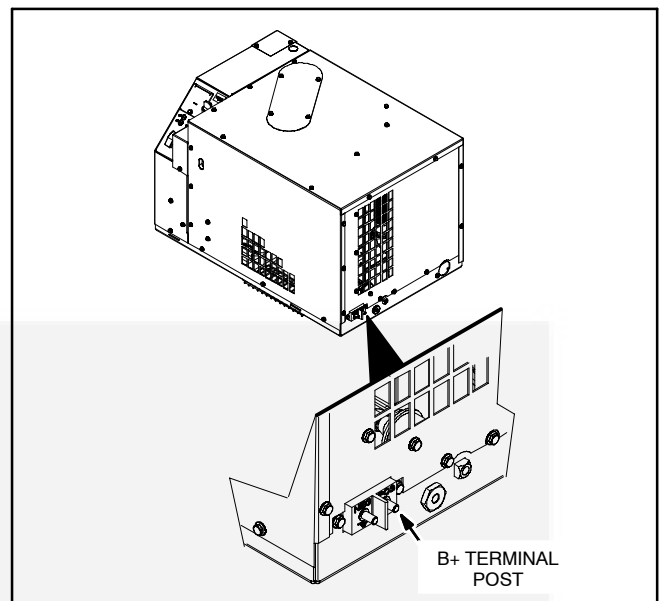

FIGURE 4-5. B+ TERMINAL ON DIESEL GENSETS

11. Reconnect the battery cables.

⚠️WARNING *Exhaust gases are hazardous and may cause severe personal injury or death. Seal all holes to prevent the entrance of exhaust gasses into the vehicle interior.*

CONNECTIONS (DEFINITIONS)

This section describes each connection to the EC-30W.

Genset Connections

WIRE A BATTERY GROUND (NEGATIVE): This wire supplies the ground or negative side of the circuit for the EC-30W genset module. It must be supplied from the genset.

WIRE B STOP/PRIME INPUT: This wire supplies the stop/prime signal to the genset. It is an active low or grounded output.

WIRE C START/PREHEAT: This wire supplies the start/preheat signal to the genset. It is an active low or grounded output.

WIRE E SWITCHED B+ FROM GENSET: This wire is switched to the battery positive voltage when the genset is running. It is used on the genset node to indicate the genset is running.

WIRE F Genset Status Light: This wire supplies a diagnostic output from the genset that flashes the red light in the START/STOP switch to indicate a genset fault. The status light output is decoded by the EC-30W to display a fault code.

Power and Communication Connections

12VDC Power Wire (purple wire): This wire is the positive power supply to the EC-30W.

WIRE G & H: Serial communication wires to genset. Not required.

TT+ (faston receptacle): This is a wire splice into Run input lead for an optional hour-meter.

TT- (faston receptacle): This is a wire splice into Ground lead for an optional hour-meter.

Sensing AC Shore Power

The UL Listed 120VAC to 5VDC plug-in power supply is equipped with the EC-30W kit. This input is used to prevent the genset from automatically starting when AC Shore Power is connected.

⚠ CAUTION *Do not connect 120VAC or 240VAC line voltage to the EC-30W! Damage will occur and will not be covered by warranty!*

FINAL CONNECTIONS AND TESTING

This section describes the final connections and test procedure to verify the unit has been installed correctly and is operating properly.

Ensuring Generator and EC-30W Connection to House Battery

Ensure that the generator set and EC-30W is connected to the house battery, not the engine battery.

1. Remove the negative battery cable for the house battery bank.
2. Press the start button on the generator to verify the generator doesn't crank.
 - If the generator cranks, then the DC connection to the generator is from an alternate set of batteries, such as the Chassis Battery bank.
 - If the battery bank is connected to the chassis batteries the connection to the generator will have to be altered to the House batteries to ensure correct AGS functions due to low battery conditions.
 - If the generator does not crank then the generator must be connected to the House Batteries.
3. Reconnect the negative terminal to the House Battery bank and check Converter/Inverter operation for correct charge.

Please contact your closest authorized Cummins Onan Facility for more information on how to properly ensure your generator set and EC-30W is connected to the house battery, and not the engine battery.

Test EC-30W Connection

The following test procedure describes a systematic method of testing both the installation and operation of the EC-30W.

Initial Synchronization

The EC-30W should be initially synched.

1. When a button is pressed, display powers on and will read, "Establishing Communication." The main screen will appear showing the time. If screen does not show time, following the preceding steps.
2. From the Main Menu, navigate to "Setup and Information" screen and press SET.

3. Press ▲ or ▼ arrow until “System Setup” screen is reached.
4. Press SET to proceed.
5. Press ▲ or ▼ arrow until “Synchronize to Genset Module” appears.
6. Press SET. The next screen will read, “Preparing for Synchronization.”
7. When display appears, hold STOP at genset to synchronize. Press and hold the stop switch at genset or remote START/STOP.
8. If device is synchronized, message will appear, “Synchronized to Genset Module.”
9. Set GEN HRS and TYPE. (See Table below for Genset Types.)
 - A. Use the ▲ or ▼ arrow to change values.
 - B. Press SET to advance to next editable value.

TABLE 4-3. GENERATOR TYPES

GEN TYPE	MODEL	SERVICE IN
NOT SET	---	---
QD 10/12	RV QD 10000 RV QD 12500	250
QD 5-8	RV QD 8000 RV QD 6000	150
GAS/LP	RV QG 5500–2200 RV QG 3600–4000	150
GAS/LP-KV	RV QG 2500–2800	150

10. Press BACK to return to main screen.

Test EC-30W Operation

1. Start and stop the genset using the STOP/START switch located on genset. This confirms the genset operation.
2. Start the genset at the EC-30W display and check the following:
 - A. LED on generator module to indicate power connection
 - B. Genset starts and continues to run
 - C. Display GEN LED light is on.

- D. Use the UP/DOWN switch to the right of the display to scroll to the house battery display and confirm that it is showing the house battery voltage.
 - E. Navigate to one of the screens which shows house temp and verify the temperature shown on the EC-30W is roughly the same as the temperature displayed by a separate thermostat inside the coach. The temperature shown by the thermostat and EC-30W display might not be exactly the same as what is on the EC-30W, however the temperatures should be reasonably close to one another.
 - F. Plug in supplied 5VDC adapter and confirm shore LED light is on.
3. Stop the genset at the controller and check the following:
 - A. The genset stops
 - B. The hour-meter stops
 - C. GEN LED light turns off
 4. Set the clock to the current local time as described on page 5-1.

AGS WARNING LABELS

The unit includes a sheet of adhesive warning labels. Affix one label at or near each of the following locations:

- Genset Service Access Panel
- Genset Start/Stop Switch
- Vehicle AC Distribution Panel
- Vehicle AC Transfer Switch
- For towed RV, tow tongue or tongue jack

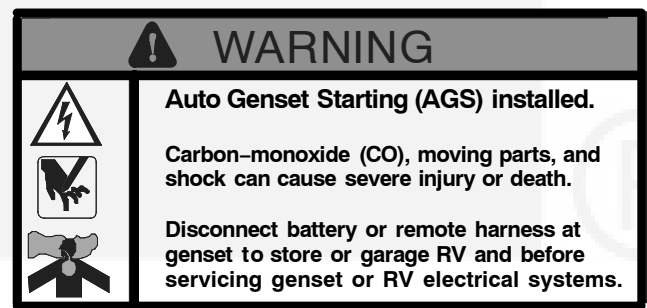

FIGURE 4-6. AGS WARNING LABEL

5. Setup & Test

General

This section describes how to Setup and Test the EC-30W. Before using the EC-30W for the first time, check to be sure that the unit is setup appropriately for the system.

MAIN MENU

Setting Time

To set the local time:

1. From the main screen, navigate to screen where time and house temperature is shown.
2. Press **SET** to enter editing screen. **Note that the hour digit flashes.**
3. Use the ▲ or ▼ key to change time.
4. Press SET to go to the minute field. Use the UP/DOWN keys to change.
5. After time is set, press BACK to go to previous screen.

Setting Auto Temperature (AUTO TEMP)

To set the Auto Temp.

1. On the main screen, navigate to “Auto Temp” screen by using the ▲ or ▼ key.
2. Press SET▶.
3. “Auto Temp Start” will appear on display. Select proper setting: Cool, Off, or Heat by using the ▲ or ▼ key.
4. Press SET▶ to move to temperature field.

5. Use ▲ or ▼ key to set temperature from 32-99°F.

Note: Default temperatures are 68°F (Heat) and 74°F (Cool).

6. Press ◀BACK to return to previous screen on main menu.

Setting “Service In & Gen Hrs”

To set “Service In & Gen Hrs.”:

1. On the main screen, navigate to “Service & Gen Hrs” screen by using the ▲ or ▼ key.
2. Press SET▶.
3. Press SET▶ again to reset service interval.

Setting QT (Quiet Time) Start & End

The Local Time is used to prohibit automatically starting the genset during Quiet Time. The QUIET TIME mode prohibits the genset from automatically starting between the start and end of Quiet Time.

To change these times:

1. Press ▲ or ▼ key to navigate to the QUIET TIME display.
2. The current setting is shown. Press SET▶ to change the setting.
3. Use the ▲ or ▼ key to change the value to on or off.
4. Press the SET▶ button to move from one field to another, and to set the start and end for Quiet Time.
5. Press ◀BACK to go to previous screen.



Setup & Information Displays

The Setup & Information displays are used to tailor the EC-30W to the particular system and application.

See *EC-30W Setup & Information Display Diagram* in Appendix A for reference.

Access Setup & Information Displays

1. From the main menu, use ▲ or ▼ key to navigate to the Setup and Information display and press SET▶.
2. Navigate with ▲ or ▼ key.
3. Press SET▶ to exit display to continue through the previous displays.

SYSTEM INFORMATION MENU

The System Information menu shows the: Genset Status, Last Auto Even, Last Fault, Display SWVx.xx/Base SWVx.xx, and Motion Data.

Genset Status Display

The genset status display shows the genset status: “Fault,” “Starting,” “Running,” “Stopped,” and “Priming.”

LAST AUTO EVENT Display

The LAST AUTO EVENT display allows access to key information. Pressing SET once will display the reason for last automatic action. Typical displays are shown below in Table 5-1:

TABLE 5-1. AUTO EVENTS

Last Auto Event display shows...	Because...	Genset...	AGS...
Manual Disable	User disabled AGS	Stopped if running	Disabled
	User manually started/stopped Genset	--	
Enabled	No other AGS events after last AGS enable	Stays stopped	Stays enabled
Motion Disable	EC-30W detected motion	Stopped if running	Disabled
Comm. Disable	Display and genset module no longer communicating	Stopped if running	Disabled
Quiet Time Stop	Quiet time began	Stopped	Stays enabled
Battery Start	House battery low	Started	Stays enabled
Battery Stop	House battery full	Stopped	Stays enabled
Temp. Start	Temperature exceeded user set limits (heat or cool)	Started	Stays enabled
Temp. Stop	Temperature is back to user set limits (heat or cool)	Stopped	Stays enabled
	Auto Temperature Start changed to Off	Stopped if running	
Gen. Fault Stop	Genset fault	Stopped if running	Disabled
Invalid Temp.	Display is sensing out-of-range temperature	Stopped if running	Disabled
Motion Fault	Accelerometer (motion sensor) diagnostics failed	Stays stopped	Disabled
Pre-fill Start	House battery not full two hours prior to the beginning of quiet time	Started	Stays enabled
Pre-fill Stop	House battery full prior to the beginning of quiet time	Stopped	Stays enabled
Max Charge Time	Genset running continuously for 12 hours, but house battery still not fully charged	Stopped	Disabled
Max Temp. Time	Genset running continuously for 24 hours, but temperature still not in user-set limits (heat or cool)	Stopped	Disabled
Failed To Stop	EC-30W commanded genset to stop, but genset didn't stop	Stays running	Disabled
Failed To Start	EC-30W commanded genset to start for three times, but genset didn't start	Stays stopped	Disabled
Verify Motion	EC-30W didn't detect any motion in last 30 days	Stopped if running	Disabled
Display Battery	Display battery is low for AGS to work appropriately	Stopped if running	Disabled
Unexpected Stop	EC-30W Genset Status changed to “Stopped” without EC-30W stop command, genset stop switch press, or genset fault indication	Stopped if running	Disabled

Last Fault #X Display

This displays the last fault received by the module. See genset operator's or service manual for fault number specific troubleshooting information.

Display SWVx.xx/Base SWVx.xx

The DISPLAY SWV shows the version control number for the display. The BASE SWV display shows the version control number for the EC-30W genset module. Should it be necessary to contact customer service this number would help determine the specific configuration of your EC-30W.

SYSTEM SETUP MENU

The Sytem Setup menu allows users to set genset hrs and genset type, unit of temperature (°F or °C). It also allows synchronization to the genset module after initial setup.

Set Gen Hrs and Gen Type Display

The "Gen Hrs and Type" display is used to select the type of genset used with the EC-30W and to adjust the genset hour meter.

Setting the gen type is required for proper operation. The very first time the EC-30W is turned on (power applied) an initial setup procedure begins. The EC-30W requires setup of both the Gen TYPE and synchornization prior to allowing automatic operation.

The genset type sets the Service Interval for service messages and critical automatic starting parameters. The first service interval is 50 hours for all models.

See Page 4–6 for setting "Gen Hrs and Type" instructions from initial power-up.

1. From the main display, use the UP/DOWN keys to navigate to SETUP AND INFORMATION display.
2. Press SET▶ and go to SYSTEM SETUP screen using the ▲ or ▼ key.
3. Press SET▶ to enter TYPE and HOURS screen.

Set Gen Hour Display:

If the EC-30W is installed on an existing genset, check the hour-meter on the genset and record the reading.

- A. Use the SET▶ button to advance through the numeric placements, use the ▲ or ▼ key to set the correct hour setting.
- B. Press the ◀BACK button to save your settings and exit the screen.

The value is stored in permanent memory and will not have to be changed unless the EC-30W is installed on a different genset.

The hour-meter in the EC-30W and the hour-meter at the genset may differ slightly over time due to small differences in accuracy. However, there should not be any complications caused by this.

Set Gen Type:

If no GEN TYPE has been selected, the display will read:

GEN HRS: 12345.6

TYPE: NOT SET

- C. Press the ▲ or ▼ key to select the correct genset hour and genset type. Refer to the table below for correct genset type.

TABLE 5-2. GENERATOR SET TYPES

GEN TYPE	MODEL	SERVICE IN
NOT SET	---	---
QD 10/12	RV QD 10000 RV QD 12500	250
QD 5-8	RV QD 8000 RV QD 6000	150
GAS/LP	RV QG 5500– 2200 RV QG 3600–4000	150
GAS/LP-KV	RV QG 2500–2800	150

- D. Gen TYPE is then stored in permanent memory and will not have to be changed unless the EC-30W is installed on a different type of genset, or if the genset module is replaced.

4. Press ◀BACK to enter when the correct genset hour and type is displayed.

Synchronization after initial setup

⚠WARNING *To satisfy FCC RF exposure requirements for mobile transmitting devices, a separation distance of 20 cm or more should be maintained between the antenna of this device and persons during device operation. To ensure compliance, operations at closer than this distance is not recommended. The antenna used for this transmitter must not be co-located in conjunction with any other antenna or transmitter.*

If poor communication between genset module and device is experienced, or display/genset module is replaced, re-synchronization is required for the display and genset module.

1. From main display, navigate to “Setup and Information” screen using ▲ or ▼ key.
2. Press SET▶ to proceed.
3. Use ▲ or ▼ key to navigate to “System Setup”
4. Press SET.
5. Use the ▲ or ▼ key to navigate menu to “Synchronize to Genset Module” display.
6. Press SET. The next screen will read, “Preparing for Synchronization.”
7. When display shows, “Hold STOP at Genset to synch.,” press and hold the STOP switch at genset or remote START/STOP until display shows “Synchronized to genset module.”
8. Once synched, press BACK to return to desired screen.

See EC-30W Display Diagram in Appendix for reference.

If the charge system is unable to reach the Full Batt. Stop voltage, the result will be excessive genset running.

Note: This setting does not change the battery charging voltage. Do not set Full Battery Stop voltage the voltage of the battery charger.

Selecting Appropriate Values

The selection of the start and stop voltages and the time required to achieve specified voltages require trade-offs. It is a balance between the number of genset-starts, the length of genset runtime, and the desired battery charge level.

The default values have been selected to ensure that the battery stays charged and the genset does not run excessively or needlessly start. It is advised that the default values be used until the performance of the system can be assessed.

Setting the Low Batt. Start higher will result in more genset starts, shorter genset runtime for battery charging, and a quicker response to voltage dips. Decreasing the setting of the time for Low Batt. Start will increase the response to voltage dips. Setting the Full Batt. Stop time longer will increase the genset runtime for battery charging.

Run the system through a complete automatic start/stop cycle after changing setting to confirm proper performance. Table 5-3 describes the effect of increasing Low Batt. Start and Full Batt. Stop voltage and time.

Note: Shore power is encouraged for use; the genset should not always be relied on to fully charge the battery.

⚠CAUTION *Avoid running lightly loaded gensets.*

Note: Charging current falls to very low levels at the end of charge. It is preferred to use shore power and not the genset to “top off” or fully charge the battery.

TABLE 5-3. EFFECT OF INCREASING LOW BATT. START AND FULL BATT. STOP VOLTAGE/TIME

Effect of Increasing	# Starts	Runtime	Battery Level
Low Batt. Start V	More	Less	Higher
Low Batt. Start Time	Less	More	Higher
Full Batt. Stop V	Less	More	Higher
Full Batt. Stop Time	Less	More	Higher

Auto Temp. Displays

The EC-30W starts and stops the genset for heat/air conditioning based on the user's temperature setting and range setting. The Auto Temp. Cool Range and Auto Temp. Heat Range displays are located in the Auto Start Setup display.

Auto Temp. Cool Range

The user can set the range in which the genset can automatically start/stop when the temperature falls out of the indicated range.

The user can set the range by entering the Auto Temp. Cool Range display from the Auto Start Setup display.

To set range:

1. Navigate to Auto Temp. Cool Range screen.
2. Press SET▶
3. Use ▲ or ▼ key to set range.
4. Press ◀Back.

If in Cool mode, and range is set $\pm 2^{\circ}\text{F}$ from the standard 70°F the genset will start if the temperature is greater than 72°F . The genset will stop if the temperature is less than 68°F .

Auto Temp. Heat Range

The user can set the range in which the genset can automatically start/stop when the temperature falls out of the indicated range. The user can set the range by entering the Auto Temp. Heat Range display from the Auto Start Setup display.

To set range:

1. Navigate to Auto Temp. Heat Range screen.
2. Press SET▶
3. Use ▲ or ▼ key to set range.

4. Press ◀Back.

If in heat mode, and range is set $\pm 2^{\circ}\text{F}$ from the standard 70°F the genset will start if the temperature is less than 68°F . The genset will stop if the temperature is greater than 72°F .

Auto Start Setup Display

The displays may be used to change the automatic starting parameters.

Low Batt. Start/State of Charge Display

Low Batt. Start Voltage Time is the voltage to which the house battery must fall and remain for the specified number of seconds to cause the genset to automatically start. Setting a shorter time will increase the number of generator starts due to temporary voltage dips, (increase the "sensitivity" to voltage dips). Setting a longer time will decrease the "sensitivity" to temporary voltage dips.

The Low Battery Start voltage range is 11.5 to 12.1 volts. A lower voltage will decrease the number of starts due to a low battery. A higher voltage will increase the number of starts due to temporary voltage dips.

Setting the Low Battery Start voltage too high may result in frequent "false" starts due to a low battery start.

Full Batt. Stop/State of Charge Display

The Full Batt. Stop voltage is the voltage to which the house battery must rise to cause the genset to automatically stop due to a full battery. The Full Batt. Stop voltage range is 12.8 to 13.4 volts. A lower voltage will not fill the battery as full but it will reduce the amount of time the genset will run. A higher voltage will fill the battery to a higher state of charge, but increase the amount of genset run-time.



Cummins

THIS PAGE LEFT INTENTIONALLY BLANK



6. General Troubleshooting

TROUBLESHOOTING

See Table 6-1 for Troubleshooting procedures.

If the EC-30W functions do not operate properly, proceed as follows:

1. Does the genset operate correctly from the genset controls with the EC-30W gen set module unplugged? If it does not, the problem is in the genset. See the genset Operator, Installation, and Service manuals.

2. If the genset operates correctly from the genset controls, check EC-30W wiring connections.

3. Check all terminal connections on both ends of the wiring harness. Are harness connectors properly joined?

For additional customer service information, contact Cummins Power Generation at 1-800-888-ONAN (6626).



TABLE 6-1. GENERAL TROUBLESHOOTING

SYMPTOM	POSSIBLE CAUSE	CORRECTIVE ACTION
[1] Display screen does not power up when a button is pressed or turns off immediately.	Display battery is dead.	If shore power is available, plug—in charger to charge the rechargeable battery. If display still does not power up, replace the rechargeable battery (and/or charger) or use two new regular AA batteries.
[2] Display Battery screen shows “Battery Fault”.	Defective battery or charger.	Cycle power to the display (remove both charger and battery and put back in). If it still shows battery fault, replace the rechargeable battery (and/or charger) or use two new regular AA batteries.
[3] Display shows significantly higher (or lower) temperature than it feels like.	Display is not located in the ambient temperature area inside the house.	Install display in a partition, not an outside wall. Never expose display to direct heat (from lamps, sun or other heat producing items) or cold air. Avoid locations close to windows or doors that lead outside.
Before performing any of the troubleshooting below, first verify that the genset module harness is connected to the genset remote harness and battery, the wiring harness is intact and the power LED on genset module is on.		
[4] Display does not communicate with genset module or occasionally loses communication (display shows “Establishing Communications” or “Re—establishing Communications” screen).	Display and genset module are not synchronized.	Synchronize display and genset module.
	Display is out—of—range of genset module.	Bring display closer to the genset module.
	EC—30W uses RF signal to communicate. Noise sources such as high voltage power lines, ignition systems, and other RF sources may interfere with wireless communication.	Re—synchronize display and genset module.
		Mount genset module as far away from EMI sources (such as the engine ignition system) as possible. Do not mount genset module inside a thick metal compartment.
[5] Display does not synchronize with the genset module (“Hold STOP at Genset to Synch.” screen does not change to “Synchronized to Genset Module”).	STOP switch is not pressed and held long enough.	When display shows “Hold Stop at Genset to Synch.” screen, press and hold STOP switch at genset or remote start/stop (NOT EC-30W STOP button) for a minute or until display changes to “Synchronized to Genset Module”.
	Display is out—of—range of genset module.	Bring display closer to the genset module and try to synchronize. If they still don’t synchronize, cycle power to genset module and display and try to synchronize again.
[6] START button is pressed and confirmed by pressing SET button, but the genset doesn’t start.	Genset battery is not connected or less than 8VDC.	Connect and charge the genset battery before attempting a genset start.
	NOTE: If the genset cranks but does not start or a genset fault is indicated while attempting to start the genset, refer to the genset operator’s or service manual for fault number specific troubleshooting information.	
[7] STOP button is pressed, but the genset doesn’t stop.	Defective wiring connections.	Check wiring harness between genset module and genset.
[8] House battery doesn’t match other display in vehicle or does not show charging voltages while converter/inverter is charging	Generator DC connections are not from the House batteries but may be connected to the Chassis Batteries. Converter/Inverter not functioning correctly.	Verify the Generator DC connection is of the House Batteries.

SYMPTOM	POSSIBLE CAUSE	CORRECTIVE ACTION
<p>[9] AUTO button is pressed and confirmed AUTO enable by pressing SET button, but the AUTO LED doesn't blink or AUTO LED turns off unexpectedly and genset stops if it's running.</p>	<p>Built-in accelerometer (motion sensor) diagnostics failed or it is sensing that vehicle is in motion (Last Auto Event is "Motion Fault" or "Motion Disable").</p>	<p>Do not mount genset module on the genset, genset hanging kit, or other vibrating surfaces. Enable AUTO start only after parking the coach/trailer on a flat and stable surface. Put jacks down and do not rock or tilt coach/trailer when AUTO start is enabled.</p>
	<p>Display and genset module no longer communicating (Last Auto Event is "Comm. Lost")</p>	<p>See [4] above</p>
	<p>Genset stopped because of a fault (Last Auto Event is "Gen. Fault Stop" or Last Fault # is other than "0").</p>	<p>See [6] above</p>
	<p>Display is sensing out-of-range temperature (Last Auto Event is "Invalid Temp.>").</p>	<p>Verify that temperature sensor and its wires located on the bottom of display (next to display charger plug) are intact.</p>
	<p>EC-30W didn't detect any motion in last 30 days (Last Auto Event is "Verify Motion").</p>	<p>See "Motion Verification" section of this manual.</p>
	<p>EC-30W commanded genset to stop, but genset didn't stop (Last Auto Event is "Failed to Stop").</p>	<p>See [7] above</p>
	<p>EC-30W commanded genset to start for three times, but genset didn't start (Last Auto Event is "Failed to Start").</p>	<p>See [6] above</p>
	<p>Display battery is low for AGS to work appropriately (Last Auto Event is "Display Battery").</p>	<p>See [1] above</p>
	<p>Genset running continuously for 12 hours, but house battery still not fully charged (Last Auto Event is "Max Charge Time").</p>	<p>Verify house battery charger is connected and working properly.</p>
	<p>Genset running continuously for 24 hours, but temperature still not with in user set limits (heat or cool) (Last Auto Event is "Max Temp. Time").</p>	<p>Verify HVAC system is enabled and working properly.</p>
	<p>EC-30W start/stop button or genset (remote) start/stop switch is pressed (Last Auto Event is "Manual Disable").</p>	<p>Avoid unintentional press of any genset start/stop button or switch; it disables EC-30W AGS operating mode.</p>
	<p>EC-30W Genset Status changed to "Stopped" without EC-30W stop command, genset stop switch press, or genset fault indication (Last Auto Event is "Unexpected Stop").</p>	<p>If genset is running but EC-30W Genset Status is "Stopped", check wiring harness between genset module and genset. If genset stopped unexpectedly without any fault indication, see genset operator's or service manual.</p>

Cummins

THIS PAGE LEFT INTENTIONALLY BLANK



Appendix A. Outline and System Drawings

DRAWING	PAGE
EC-30W MAIN MENU DISPLAY DIAGRAM	A-2
EC-30W SETUP AND INFORMATION MENU DIAGRAM	A-3
EC-30W SYSTEM BLOCK DIAGRAM	A-4

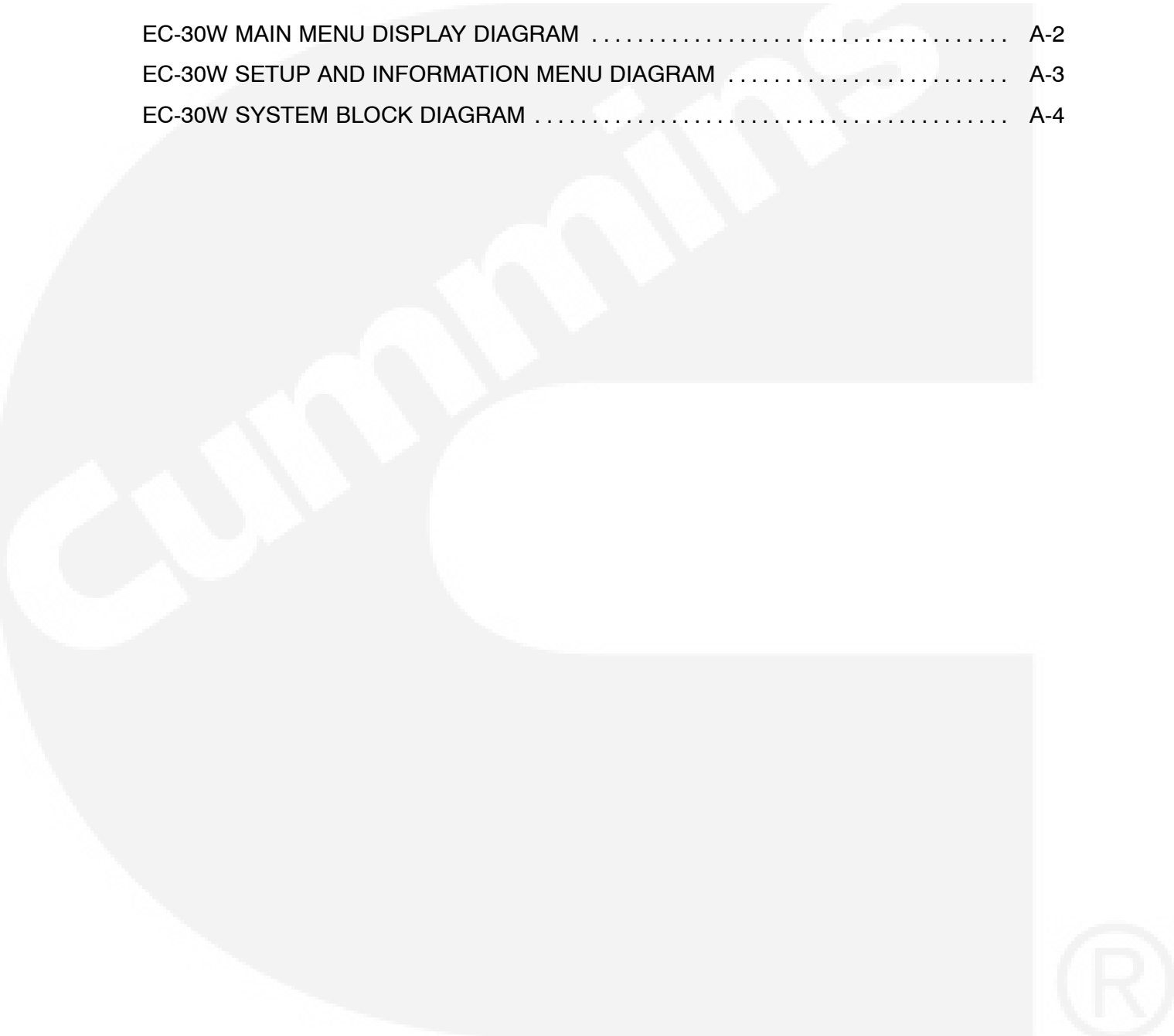

Main Menu

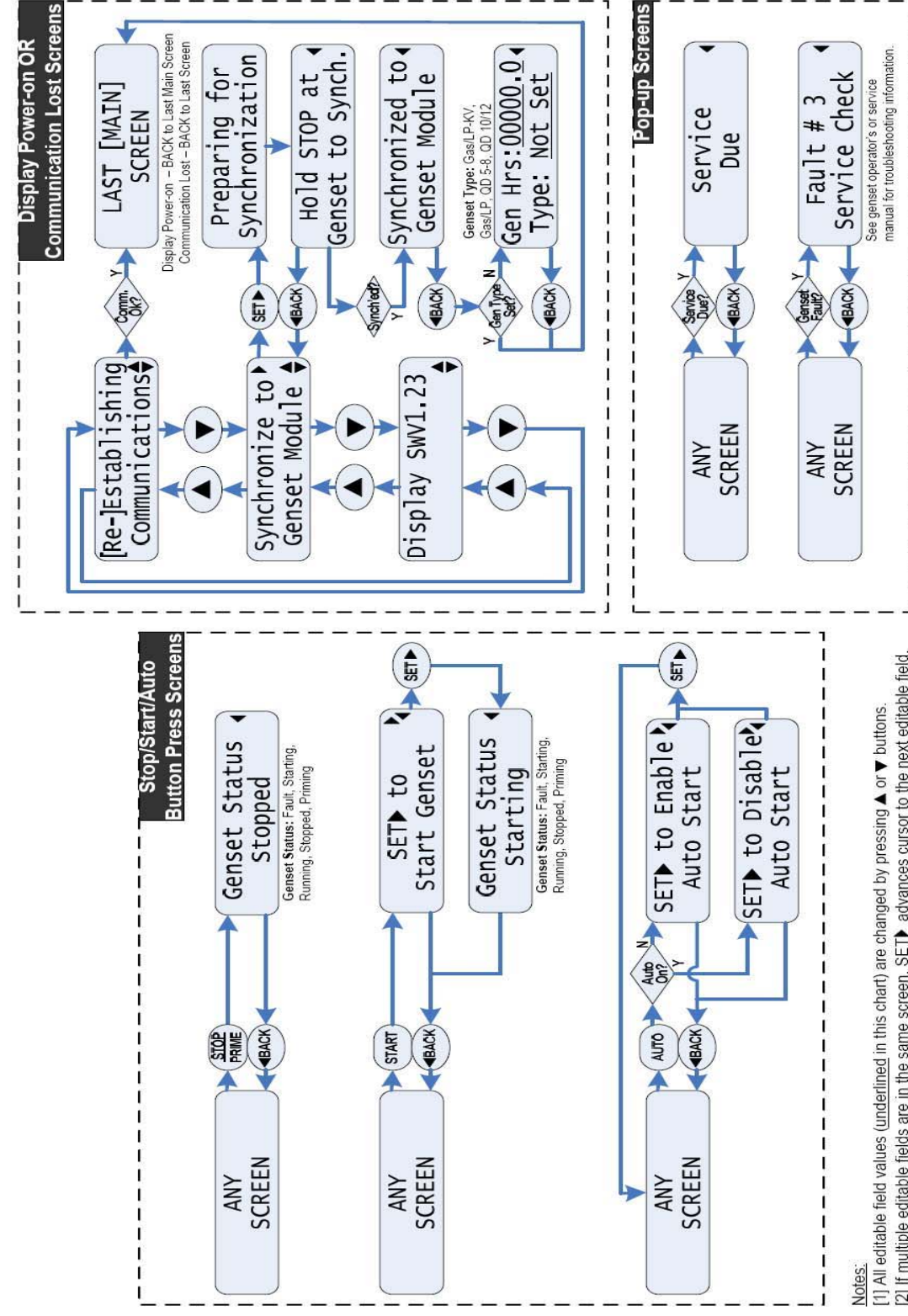
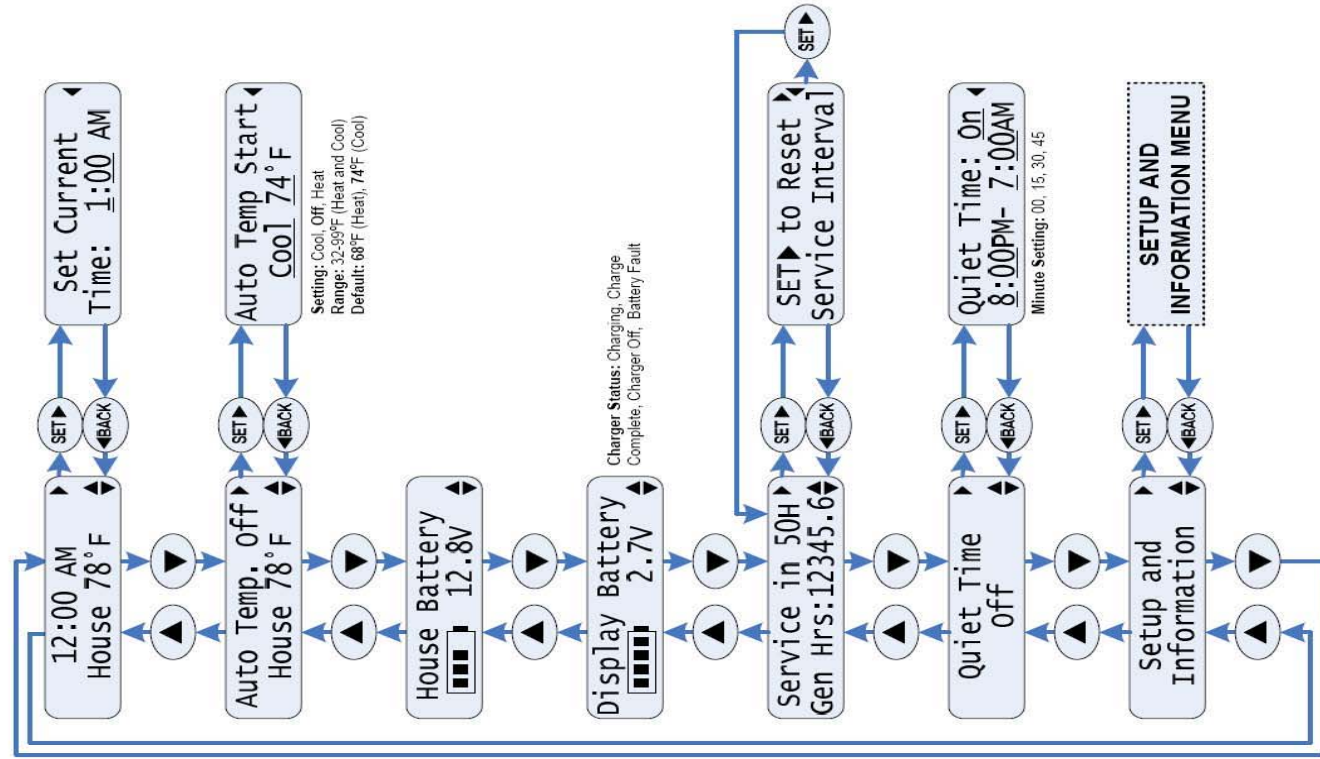

Setup and Information Menu

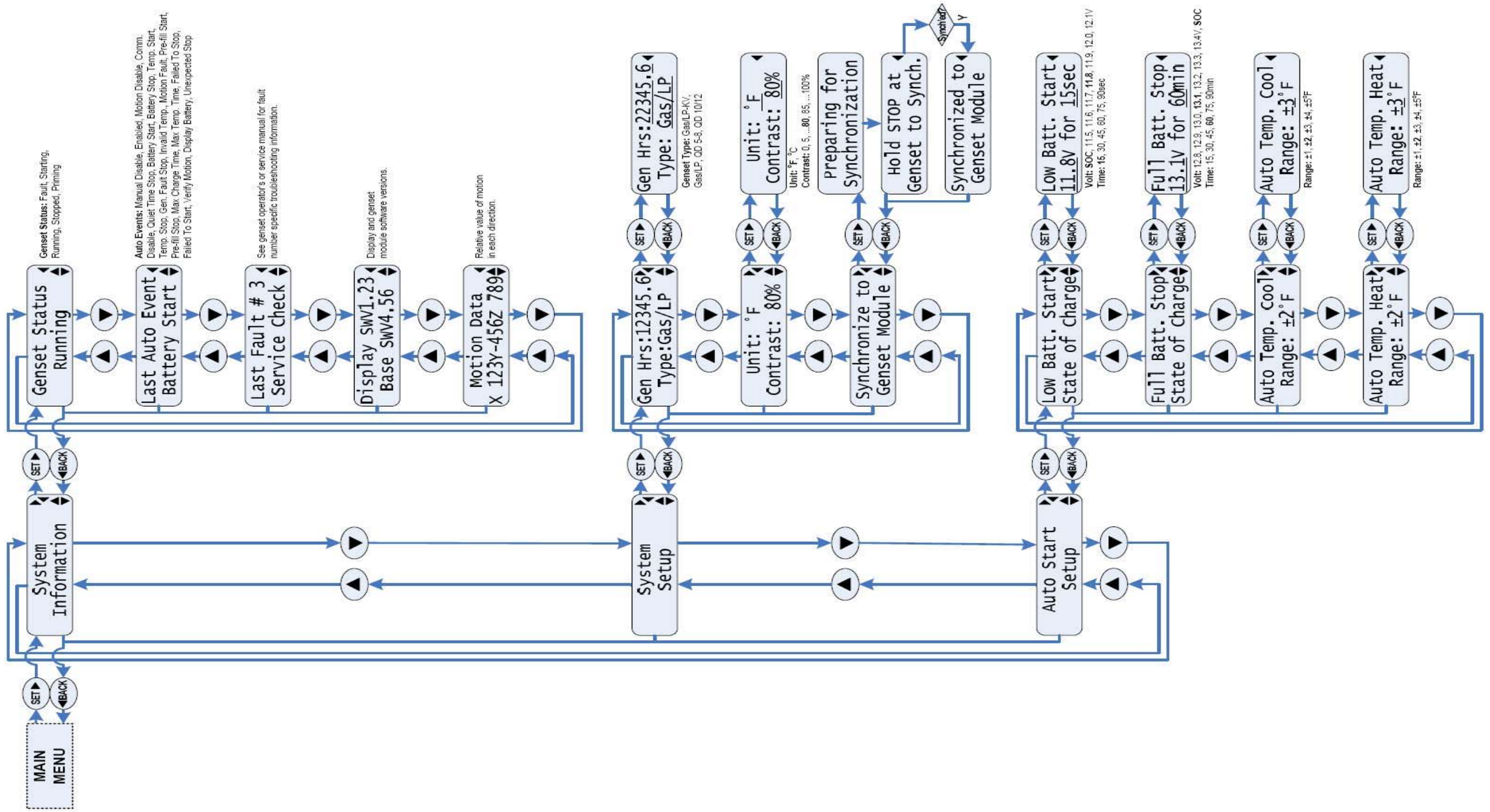

EC-30W SETUP AND INFORMATION MENU DIAGRAM

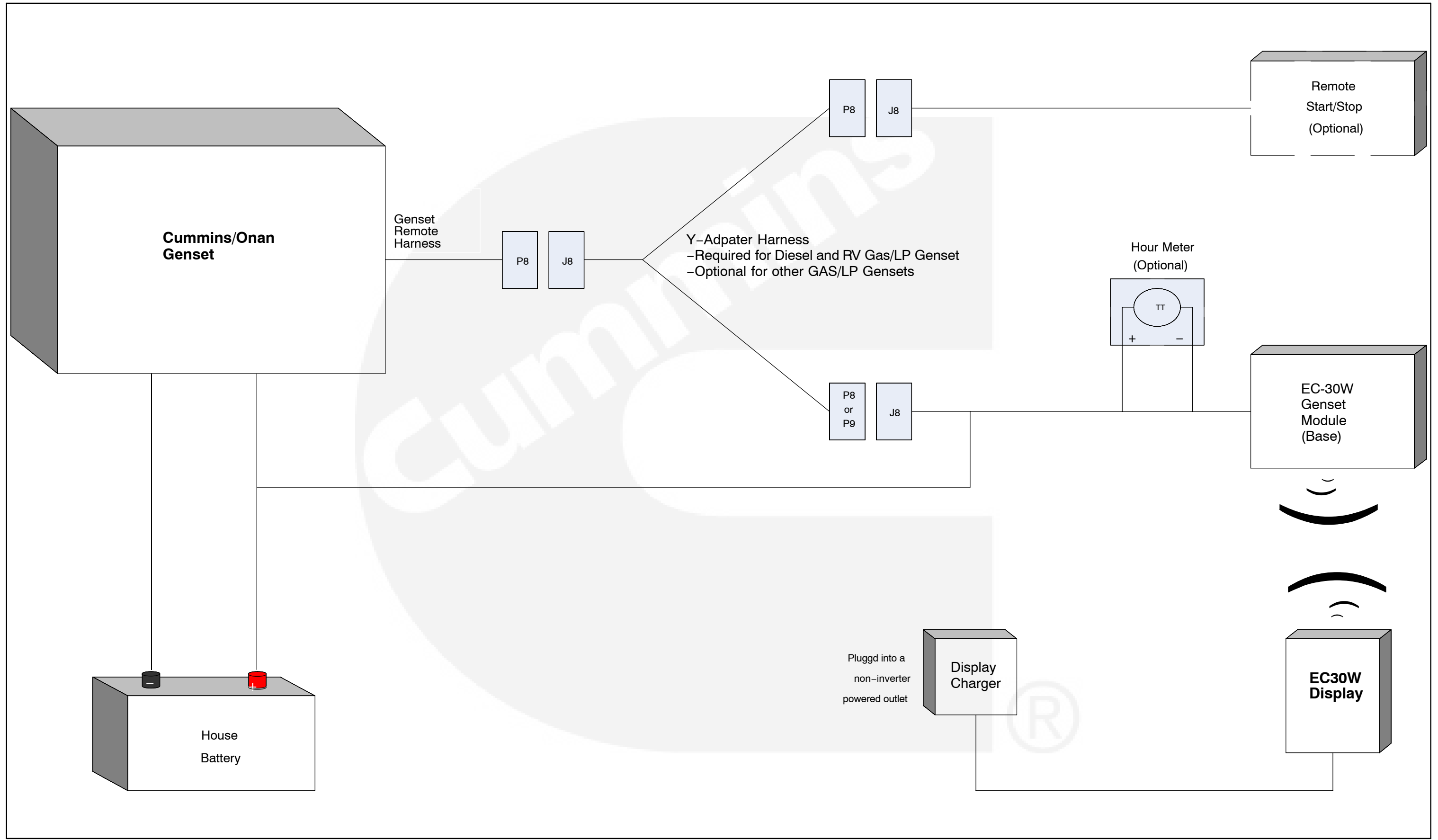

EC-30W SYSTEM BLOCK DIAGRAM

Appendix B. EC-30W References

QUIET DIESELS

MODEL	kW	PRODUCT	EC-30W GEN TYPE	SERVICE (HOURS)	CRANK (SECS)	ONAN IN CABLE NO.
HDCAx	10/12	Quiet Diesel	QD 10/12	250	30	044-00076
HDKCx	10/12	Quiet Diesel	QD 10/12	250	30	044-00076
HDKAx	6/8	Quiet Diesel	QD 5-8	150	30	044-00076
HDKBx	5.5	Quiet Diesel	QD 5-8	150	30	044-00076
HDKBx	5.0	Quiet Diesel	QD 5-8	150	30	044-00076

GASOLINE/LIQUID PETROLEUM (LP) WITH STATUS LIGHT

MODEL	kW	PRODUCT	EC-30W GEN TYPE	SERVICE (HOURS)	CRANK (SECS)	ONAN IN CABLE NO.*
HGJAx	7.0	Marquis Platinum	GAS/LP	150	18	044-00075
HGJAx	5.5	Marquis Gold	GAS/LP	150	18	044-00075
KY	4.0/3.6	MicroQuiet	GAS/LP	150	18	044-00075
KYD	4.0/3.6	CampPower	GAS/LP	150	18	044-00075

GASOLINE/LIQUID PETROLEUM (LP) (without Status Light)

Note 1: This genset model does not support diagnostic fault codes.

MODEL	kW	PRODUCT	EC-30W GEN TYPE	SERVICE (HOURS)	CRANK (SECS)	ONAN IN CABLE NO.
KVD	2.8/2.5	CampPower (Note 1)	GAS/LP-KV	150	18	044-00074
KV	2.8/2.5	MicroLite (Note 1)	GAS/LP-KV	150	18	044-00074

* Not needed if remote start/stop is not included.



THIS PAGE LEFT INTENTIONALLY BLANK



Cummins

Cummins **Onan**

Cummins Power Generation

1400 73rd Ave. NE
Minneapolis, MN 55432 USA

Phone 1 763 574 5000

Toll-free 1 800 888 6626

Fax 1 763 574 5298

Email www.cumminsonan.com/contact

www.cumminsonan.com

Cummins®, Onan®, the "C" logo, and "Performance you rely on." are trademarks of Cummins Inc.

©2007 Cummins Power Generation, Inc. All rights reserved.

