



T-012

<http://stores.ebay.com/UsefulCDs>

**technical bulletin**

**INSTALLATION OF ELECTRIC GENERATING SETS  
FOR  
RECREATIONAL VEHICLES**

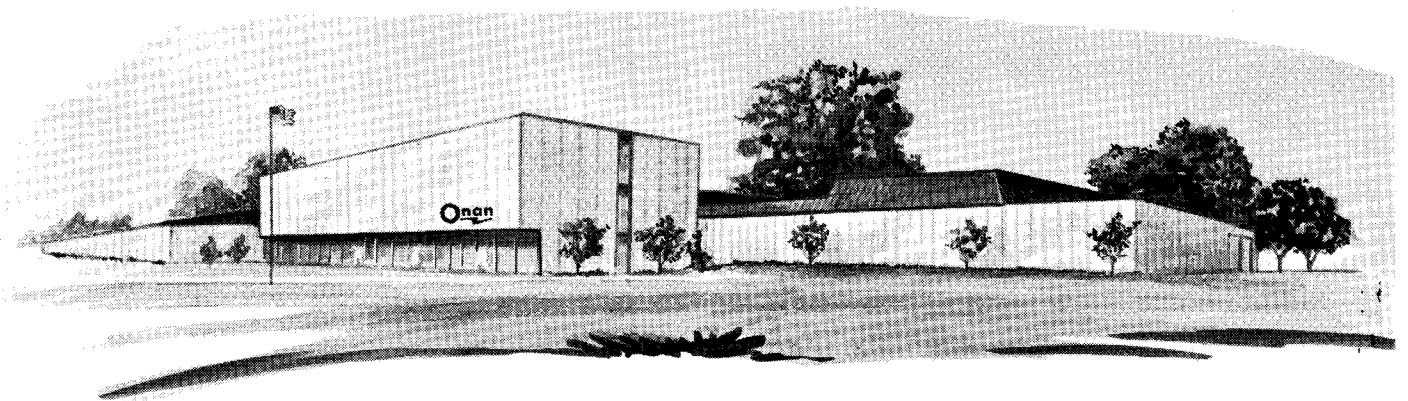

© 2006 UsefulCDs

**ONAN**

1400 73RD AVENUE N.E. • MINNEAPOLIS, MINNESOTA 55432  
A DIVISION OF ONAN CORPORATION

© 2006 UsefulCDs

Printed in U.S.A.

OCTOBER 1976

# SAFETY PRECAUTIONS

The following symbols in this manual signal potentially dangerous conditions to the operator or equipment. Read this manual carefully. Know when these conditions can exist. Then, take necessary steps to protect personnel as well as equipment.

**WARNING** Onan uses this symbol throughout this manual to warn of possible serious personal injury.

**CAUTION** This symbol refers to possible equipment damage.

Fuels, electrical equipment, batteries, exhaust gases and moving parts present potential hazards that could result in serious, personal injury. Take care in following these recommended procedures.

- **Use Extreme Caution Near Gasoline. A constant potential explosive or fire hazard exists.**

Do not fill fuel tank near unit with engine running. Do not smoke or use open flame near the unit or the fuel tank.

Be sure all fuel supplies have a positive shutoff valve.

Fuel lines must be of steel piping, adequately secured and free of leaks. Use a flexible section of fuel line between generator set and stationary fuel line in the vehicle. This flexible section must be 100% NON-METALLIC to prevent electrical current from using it as a conductor.

Have a fire extinguisher nearby. Be sure extinguisher is properly maintained and be familiar with its proper use. Extinguishers rated ABC by the NFPA are appropriate for all applications. Consult the local fire department for the correct type of extinguisher for various applications.

- **Guard Against Electric Shock**

Remove electric power before removing protective shields or touching electrical equipment. Use rubber insulative mats placed on dry wood platforms over floors that are metal or concrete when around electrical equipment. Do not wear damp clothing (particularly wet shoes) or allow skin surfaces to be damp when handling electrical equipment.

Jewelry is a good conductor of electricity and should be removed when working on electrical equipment.

Always use an appropriately sized, approved double-throw transfer switch with any standby generator set. **DO NOT PLUG PORTABLE OR STANDBY SETS DIRECTLY INTO A HOUSE RECEPTACLE TO PROVIDE EMERGENCY POWER.** It is possible for current to flow from generator into the utility line. This creates extreme hazards to anyone working on lines to restore power.

Use extreme caution when working on electrical components. High voltages cause injury or death.

Follow all state and local electrical codes. Have all electrical installations performed by a qualified licensed electrician.

- **Do Not Smoke While Servicing Batteries**

Lead acid batteries emit a highly explosive hydrogen gas that can be ignited by electrical arcing or by smoking.

- **Exhaust Gases Are Toxic**

Provide an adequate exhaust system to properly expel discharged gases. Check exhaust system regularly for leaks. Ensure that exhaust manifolds are secure and not warped.

Be sure the unit is well ventilated.

- **Keep The Unit And Surrounding Area Clean**

Remove all oil deposits. Remove all unnecessary grease and oil from the unit. Accumulated grease and oil can cause overheating and subsequent engine damage and may present a potential fire hazard.

Do NOT store anything in the generator compartment such as oil cans, oily rags, chains, wooden blocks etc. A fire could result or the generator set operation may be adversely affected. Keep the floor clean and dry.

- **Protect Against Moving Parts**

Avoid moving parts of the unit. Loose jackets, shirts or sleeves should not be permitted because of the danger of becoming caught in moving parts.

Make sure all nuts and bolts are secure. Keep power shields and guards in position.

If adjustments *must* be made while the unit is running, use extreme caution around hot manifolds, moving parts, etc.

Do not work on this equipment when mentally or physically fatigued.

# Table of Contents

<b>GENERAL</b> .....	2
Model Selection .....	2
Considering Load Applications .....	2
Air Conditioning Loads .....	2
<b>LOCATION</b> .....	4
Compartment Location .....	4
Compartment .....	5
Mounting .....	5
Vibration Isolators .....	5
<b>VENTILATION AND ACOUSTICS</b> .....	7
Vacu-Flo Cooling .....	7
Air Requirements .....	7
Suggestions for Quieter Operation .....	7
<b>FUEL SYSTEM</b> .....	10
Fuel Consumption .....	10
Fuel Lines and Fuel Filters .....	10
Fuel Solenoid .....	11
Gasoline Evaporative Control Systems .....	11
<b>EXHAUST SYSTEM</b> .....	13
Exhaust Spark Arresters .....	13
<b>ELECTRICAL LOADS AND CONNECTIONS</b> .....	14
Wire Types .....	14
Disconnect Switch .....	14
Recommended Transfer Mechanisms .....	14
Load Connections .....	14
Starting Controls .....	16
Final Check-Out Procedure .....	16
<b>BATTERIES</b> .....	18
Battery Care .....	18
Batteries and Battery Cables .....	18
Battery Cables .....	18
Battery Selection .....	18
Battery Size .....	18
<b>REMOTE ACCESSORIES</b> .....	19
<b>PRE-START CHECKS</b> .....	21

## **WARNING**

*TO PREVENT FIRE OR ACCIDENT HAZARD . . .  
THIS UNIT MUST BE INSTALLED ACCORDING  
TO THE MANUFACTURER'S DETAILED IN-  
STALLATION PROCEDURES OBSERVING ALL  
MINIMUM CLEARANCES.*

*TO AVOID POSSIBLE PERSONAL INJURY OR  
EQUIPMENT DAMAGE, ANY INSTALLATION  
AND ALL SERVICE MUST BE PERFORMED BY  
QUALIFIED PERSONNEL.*

# General

The requirements and recommendations throughout the bulletin are based on the:

1. National Electrical Code (NEC).
2. Recreational Vehicle Institute, Inc. (ANSI A119.2).
3. National Fire Protection Association (NFPA 501C).
4. Recommendations of Onan engineers, distributors, dealers and servicemen.
5. CSA Requirements (Bulletin #946).

All requirements and recommendations are used in conjunction with manufacturers of motor homes, display vehicles, trailers and associated RV equipment. State and local codes must also be followed.

Due to various recreational vehicle chassis types and different installations, information given is quite general and must be adapted for particular installations. Refer to the appropriate operator's manual and/or installation guide for specific information.

## MODEL SELECTION

Size, weight, electrical characteristics, etc., are important when determining the correct Onan generator set for a given recreational vehicle application. However, read the entire bulletin covering cooling, fuel and wiring before making a final choice if the unit is expected to:

1. Deliver rated output when installed in compartment.
2. Start dependably.
3. Operate safely.
4. Be serviceable.

## CONSIDERING LOAD APPLICATIONS

When determining the size of the generator set thought to be needed for a given electrical load, consider the following points:

1. Total appliance loads to be used . . . refrigerator, water heater, water pump, etc. Note starting loads since they place higher demands than running loads. See Table 2.  
Consider air conditioning loads separately since they are often the largest load in the recreational vehicle (see *Air Conditioning Loads*).
2. Loads which operate simultaneously.
3. Extra loads which might be added in the future.

## AIR CONDITIONING LOADS

Probably the largest single load encountered for the electric generating set in a recreational vehicle installation is an air conditioner. Generator set sizing, more often than not, is dependent on the nature and characteristics of the air conditioner. Most air conditioners used are designed to operate from a commercial power source and can present problems to electric generating set. For this reason, care must be taken in selecting the set for air conditioning loads.

Current draw from any air conditioner is high while starting and becomes less as the air conditioner's motor reaches synchronizing speed. The instant the air conditioner's compressor starts pumping refrigerant, the load on the motor and current draw increases again. After the inside temperature of the recreational vehicle lowers, motor load and motor current draw declines. The air conditioner operates

**TABLE 1. ELECTRIC GENERATING SETS**

MODEL	ELECTRICAL CHARACTERISTICS					WEIGHT (LB)
	WATTS	VOLTS	AMP	PHASE	WIRE	
2.5LK-3CR	2,500	120/240	20.8-10.4	1	4*	225
2.7AJ-1R	2,750	120	22.9	1	2	147
4.0CCK-3CR	4,000	120/240	33.4-16.7	1	4*	290
4.0BF-3CR	4,000	120/240	33.4-16.7	1	4*	217
4.0BF-1R	4,000	120	33.4	1	2	300
5.0CCK-3CR	5,000	120/240	41.6-20.8	1	4*	315
6.0NH-1R	6,000	120	50.0	1	2	382
6.5NH-3CR	6,500	120/240	54.2-27.1	1	4*	327

\* - Can be two-wire connected for rated output at 120 volts or three-wire connected for 120/240 volts. Higher ampere rating shown is for 120 volts.

**TABLE 2.  
POWER REQUIREMENTS FOR APPLIANCES**

Appliance or Tool	Approximate Running Wattage
Refrigerator .....	600-1000
Electric broom .....	200-500
Coffee percolator.....	550-700
Electric frying pan .....	1000-1350
Hair dryer .....	350-500
Electric stove (per element) .....	350-1000
Electric iron .....	500-1200
Radio .....	50-200
Electric water heater.....	1000-1500
Space heater .....	1000-1500
Electric blanket.....	50-200
Television .....	200-600
Electric drill .....	250-750
Battery charger.....	Up to 800
Electric water pump .....	500-600
Air Conditioner.....	1400-2200
Converter .....	300-350
Microwave Oven.....	700-1500

for some time and probably stops. Restarting the air conditioner, probably the largest single starting test for the generator set, is more difficult because the internal temperature of the air conditioner has become much higher. With these points in mind, use the set selection procedure following.

1. Determine the running watts of each air conditioner from the nameplate. For operation in 100° F ambients, add 300 watts to the running watts. See Table 3.
2. Select the electric generating set from Table 4. It gives the available accessory load in watts of each set while starting various air conditioners in ambients up through 100° F.

Available accessory load will vary from installation to installation. Factors affecting this amount are altitude, carbon and lead buildup in engine, ambient temperature, compartment cooling system design, type of air conditioner and its starting time. Some can be compensated for by derating to assure the set and air conditioner operate properly. See steps 3 and 4.

3. Derate the generator set 4.5 percent for each 1000 feet above 1000-foot altitude (9 percent at 3000-foot altitude, for example).
4. Carbon and lead deposits in the set engine require a 10 percent derating if not removed after each 500 hours of operation.

**TABLE 3.  
TYPICAL AIR CONDITIONER LOADS**

BTU AIR CONDITIONER	ONE AIR CONDITIONER'S LOAD (WATTS)
11,000	1800
12,000	2000
13,500	2200

**TABLE 4. ELECTRIC GENERATING SET STARTING CAPACITIES (100° F Ambient) AND AVAILABLE ACCESSORY LOADS\***

Series	Available Accessory Load (Watts) While Starting One Air Conditioner			Available Accessory Load (Watts) While Starting Two Air Conditioners**		
	11,000 BTU	12,000 BTU	13,500 BTU	11,000 BTU	12,000 BTU	13,500 BTU
2.5LK	1300	1000	800	Not Recommended		
2.7AJ	1500	1200	1000			
4.0BF-3CR	2500	2300	2000			
4.0BF-1R Power Drawer	2500	2300	2000	2000		
4.0CCK-3CR	2500	2300	2000			
5.0CCK-3CR	3800	3500	3300			
6.0NH-1R Power Drawer	4600	4400	4100	2000	1800	1600
6.5NH-3CR	5000	4800	4400	3200	2600	2200
				3800	2800	2500

\* - Available accessory loads based on typical values for recreational vehicle air conditioners from Table 3 and set capacities.

Add 500 watts to available accessory load after vehicle interior cools to 80° F.

\*\* - Simultaneous starting.

# Location

## COMPARTMENT LOCATION

Compartment location is determined largely by:

1. Physical size.
2. Access opening.
3. Mounting support . . . most important of all.

## Physical Size

The area in the vehicle for the electric generating set must be large enough for the compartment with minimum clearance between the generator set and compartment walls or ceiling (and acoustical material, if used) as specified by Onan in each individual installation guide.

## Access Opening

Plan the location for an access opening large enough to permit set removal. Compartment door should be

designed for easy removal, or so door can be propped up for operator's or serviceman's ease.

## Mounting Support

Because of compartment weight, the most desirable mounting location is between the main frame members of the recreational vehicle. However, this is seldom possible. Most common installations are on the side of the vehicle and most difficult to reinforce. One side of the compartment is fastened to the frame and the opposite side secured to the body (Figure 1). Channel, box or angle iron can be used for a compartment frame with a sheet metal cover.

The compartment can be supported from above when the unit is below the level of the recreational vehicle main frame members. However, compartment structural design must be rugged enough to withstand severe forces in all directions.

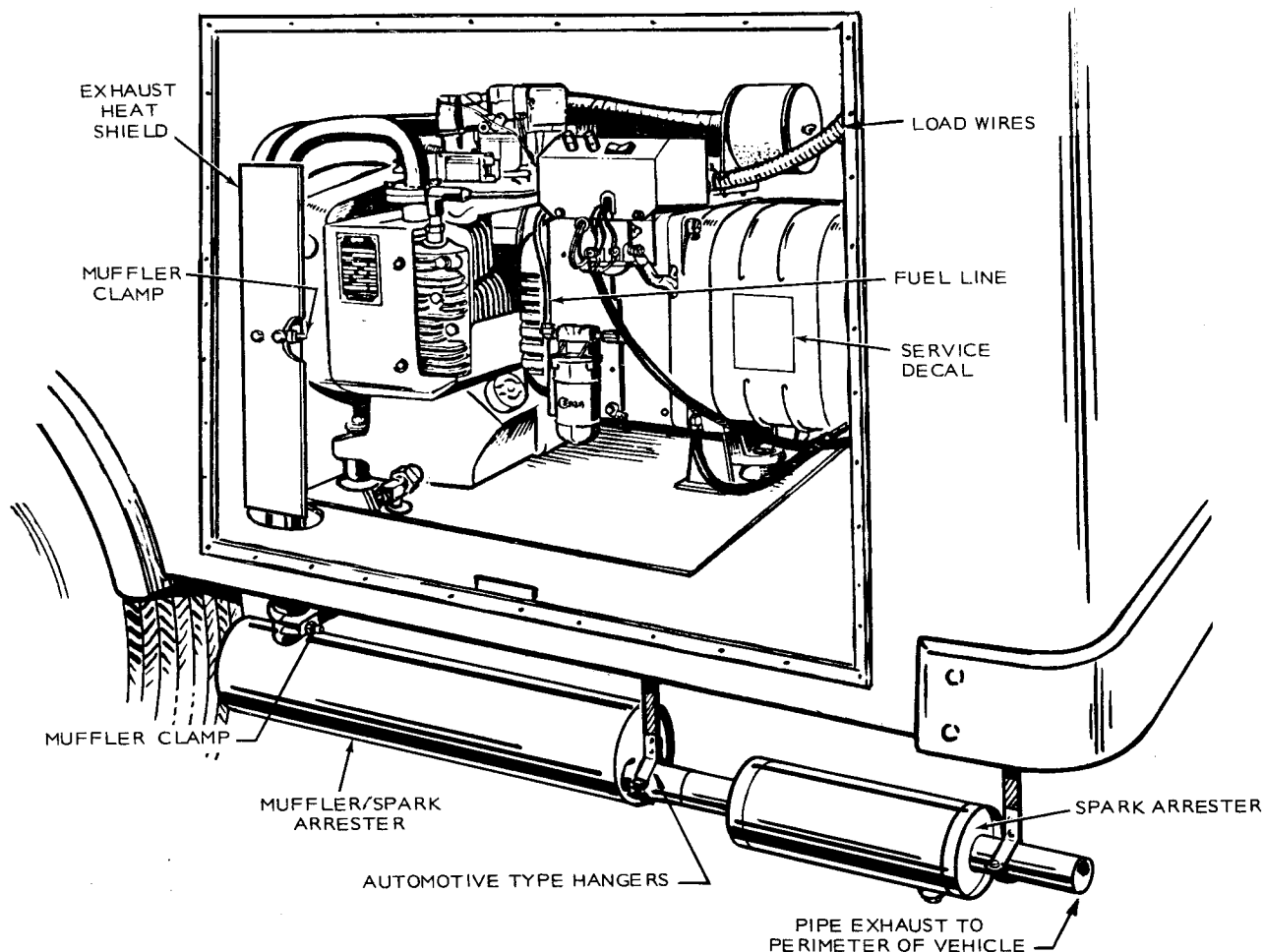

FIGURE 1. TYPICAL ELECTRIC SET INSTALLATION

## COMPARTMENT

1. Compartment or installation area must be separated from living quarters by a vapor-tight wall.
2. Line the compartment or separate generator set from living quarters with a fire barrier of sheet metal or other noncombustible material. The compartment can also be readily sealed and lends itself easily to sound or acoustical treatment.

**WARNING** Do not use flammable material directly above or around the generator set compartment. Heat transferred through the sheet metal compartment structure or other material can be high enough to discolor, char or ignite fiberboard, seat cushions, etc. Use of asbestos or other noncombustible temperature insulating material in high temperature areas may be necessary.

3. Clearance between compartment walls or ceiling (and acoustical material, if used) and set should be adequate to prevent the temperature of combustible material from exceeding 117°F (65°C) rise. For models with generator cooling inlets on the generator end, make sure adequate clearance (one inch minimum) is left for entrance of cooling air. Refer to individual installation guides for UL listed models.
4. Compartment bottom must have minimal openings to reduce entrance of road dirt.
  - A sheet metal base plate is desirable. However, plywood of sufficient thickness for strength can be used if covered with sheet metal for protection.
  - Equip base with a drain hole to outside of compartment.

**WARNING** Be sure hole is not directly above muffler to prevent fire hazard.

- Do not use absorbent material on inside of compartment floor.
5. Locate the battery outside generator set compartment. See the section on *Batteries*.

## MOUNTING

Before actual mounting of the generator set takes place, read the entire bulletin. Also, consider the following mounting points:

1. Air cleaner should be easy to remove.
2. Battery or batteries must be accessible.
3. Oil fill, drain and oil dipstick should be easy to reach and service.

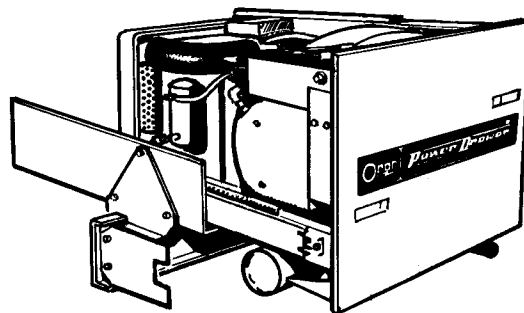

FIGURE 2. TYPICAL "POWER DRAWER" MODEL

4. Sufficient clearance must be left around exhaust system See *EXHAUST* section.

Though not usually the case due to installation restrictions, Onan RV sets of 6500 watts and less can have a compartment with the unit on a pull-out tray for service and repair. Load wires, control wires and fuel lines must have sufficient slack and flexibility so unit can slide out without disconnecting them. The 4.0BF and 6.0NH Power Drawer models are self-contained generator sets mounted on a pull-out drawer as standard. Their fuel and electrical connections are on the outside of the compartment. See Figure 2.

If the unit has a mounting plate, bolt the unit and plate securely in place. If the unit does not have a plate, see *Vibration Isolators*.

## VIBRATION ISOLATORS

Rubber vibration isolators are furnished with all Onan recreational vehicle models.

**CAUTION** Use only the vibration isolators provided with the electric generating set, as they are designed to support unit's weight.

1. Onan mounts are a "fail safe" type which prevent the unit from breaking loose if they are damaged.
2. Vibration isolators of the type shown on the lower right (with snubbing washers) in Figure 3 must be installed properly to minimize vibration. Leave 1/16-inch minimum clearance between the snubbing washers as shown.

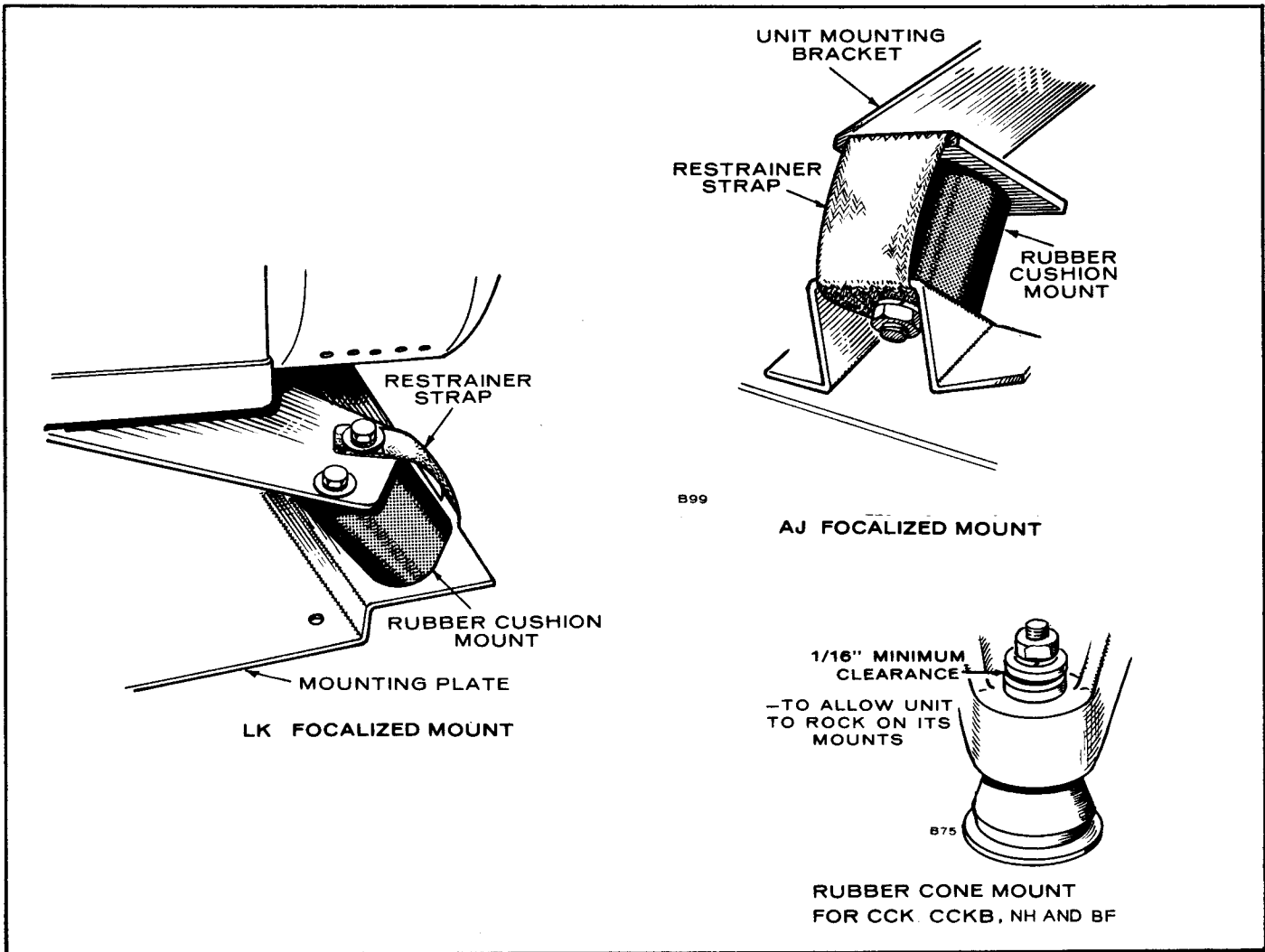

**FIGURE 3. VIBRATION ISOLATORS**



# Ventilation and Acoustics

The most important factors of ventilation for an air-cooled RV electric generating set are sufficient incoming cooling air and exhausting heated air. Before considering the installation problems, knowledge of how an Onan unit cools itself is needed.

## VACU-FLO COOLING

All Onan electric generating sets for recreational vehicles use Vacu-Flo cooling, a centrifugal fan in a scroll housing on the engine end (Figure 4).

1. It draws air from the generator end of the compartment, through the generator and over the cooling surfaces of the engine, then discharges the heated air out through the Vacu-Flo discharge opening.
2. All standard sets for recreational vehicles have the Vacu-Flo scroll positioned downward. Be sure nothing obstructs or restricts discharged airflow.

**WARNING** Never use discharged cooling air for heating since it can contain poisonous gases.

Allow for ducts or obstructions of airflow. Position of the air openings must permit airflow while the unit is running to purge the compartment of heated air. But on shutdown, the openings must allow for convection cooling of the compartment for heated air to escape.

## AIR REQUIREMENTS

Cooling air requirements for Onan electric generating sets vary with type and size. While figures

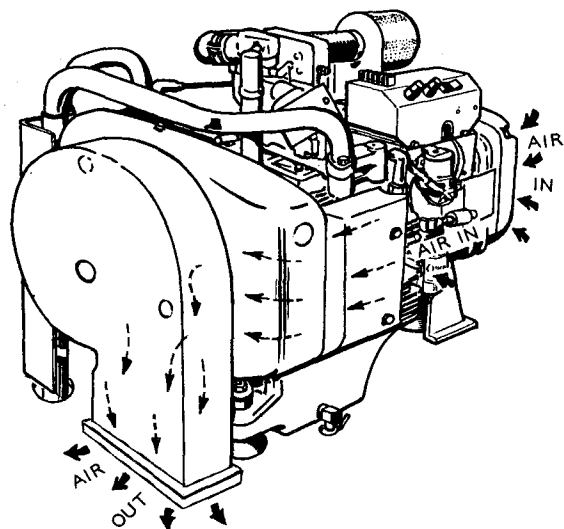

FIGURE 4. TYPICAL ONAN RV COOLING SYSTEM

TABLE 5. RV ELECTRIC SET AIR REQUIREMENTS\*

RV SERIES	RPM	AIR DISCHARGE (CU.FT./MIN.)	MIN. FREE AIR INLET, NO RESTRICTION (SQ. IN.)	MIN. AIR OUTLET SIZE (SCROLL OPENING)
2.5LK	1800	450	100	(3 x 8)
2.7AJ	3600	325	75	(4½ x 7)
4.0CCK	1800	550	100	(3 x 8)
4.0BF	1800	480	85	(9½ x 3½)
5.0CCK	1800	550	100	(3 x 8)
6.5NH	1800	650	120	(4 x 8)

\* - BF and NH "Power Drawer" models have fixed air inlet and outlet.

NOTE: Allow for airflow restrictions due to elbows in a duct, etc.

for air discharge are given in Table 5, special equipment is needed to measure it. Since the discharge area can't be changed, air inlet opening is critical. Table 5 also gives the total free inlet area recommended.

## Restricted Air Openings

Expanded metal, screen or sheet metal with louvers or slots can be used over inlet areas. However, some provide only 60 percent free inlet area per square foot. Even the most efficient grille only provides about 90 percent free inlet area per square foot. The free inlet area of the material can be obtained from the manufacturer. Calculate the inlet area needed using the following example as a guide.

**Example:** Unrestricted air inlet requirements for a generator set is 140 square inches. The compartment door louvers provide 85 percent free inlet area per square foot. Divide 140 square inches by 0.85 (85 percent) to determine necessary inlet area.

$$\frac{140 \text{ sq. in.}}{0.85} = 165 \text{ sq. in.}$$

## Air Inlet Location

If possible, always locate the air inlet on the side of the vehicle and as high as possible to minimize entrance of dirt and dust. With a rear air inlet, the generator set often has difficulty moving sufficient cooling air through the compartment, due to the vacuum created behind the vehicle during transit.

## SUGGESTIONS FOR QUIETER OPERATION

Two general types of noise encountered with a generator set for recreational vehicles are airborne and structural vibration noise. Most structural vibration noises can be reduced by vibration isolators, skin dampers in the form of lead-filled plastic or other

high-density attachable materials, flexible fuel and electrical connections, etc. Compartment acoustical lining and special compartment design can usually reduce airborne noises.

## Compartment Acoustical Lining

1. Be sure all joints and corners of the compartment are vapor tight to coach interior before lining with acoustical material.

**Lining the compartment does little if opening, cracks, door and joints are not sealed. Also make sure compartment door edge is sealed to eliminate noise-air leaks around the door perimeter.**

2. Cover the sound reflective surfaces, back, top and sides (not compartment base) with fiberglass or other noncombustible acoustical material. It should be no less than one-inch thick and approximately four pounds per square foot in density. Be sure adhesive used is also noncombustible. Test acoustical material and adhesive for heat effects before using.
3. Rather than using fiberglass or like material of four pounds per square foot density, a combination of materials can reduce noise even more. For example, a sheet of lead or viscoelastic material of one-half to one pound per square foot density and a layer of one-inch acoustical material of four pounds per square foot density, respectively, is far more superior.
4. To prevent line of sight noise indication, a sound panel (baffle) may be added behind lowered air inlet. The panel must be spaced to allow for minimum free air inlet of 100 square inches. See Figure 5.

### WARNING

Separate installation area or compartment from living quarters by a vapor-tight wall to prevent entrance of noxious fumes to interior.

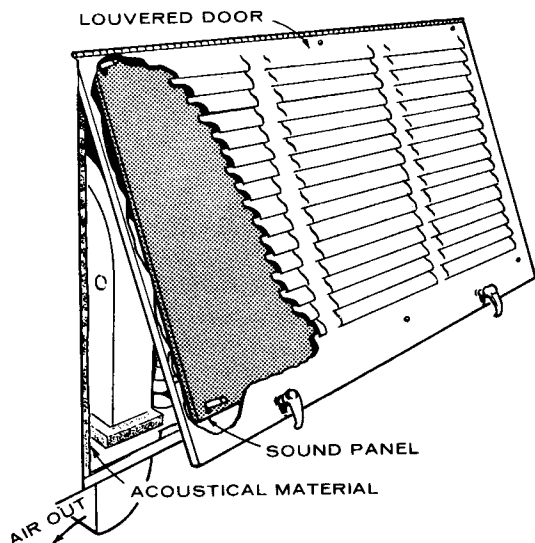

FIGURE 5. BAFFLE CONCEPT COMPARTMENT

## Compartment Design

Compartments can be designed to prevent line-of-sight noise radiation. Four types of compartment designs are discussed:

1. Baffle concept.
2. Shelf concept.
3. Panel concept.
4. Z-duct concept.

The baffle concept is accomplished by mounting a panel on the inside of a louvered service door (Figure 5). The panel must be spaced to allow for free inlet airflow, yet not allow line-of-sight to the generator set. Often this compartment does not lend itself to effective noise reduction because the louvers in the door extend beyond the panel's edges.

Shelf-concept compartments are effective because they allow more acoustical material to be used on the air inlet. The incoming air goes past the unit and must make one 90-degree turn before entering the compartment proper (Figure 6). Available space above or beside the generator set determines the depth of the shelf. Depth of the shelf must not restrict airflow.

However, due to space limitations, the shelf-concept is seldom possible. For such instances the panel concept can be used (Figure 7). It requires very little room and prevents line-of-sight to the noise source.

One of the most effective compartment designs is the Z-duct concept. Incoming air must make at least one 90-degree turn (usually two) before it enters the compartment. See Figure 8. Depth of the duct must be determined to allow for inlet air and still allow for clearance between the generator set and the back

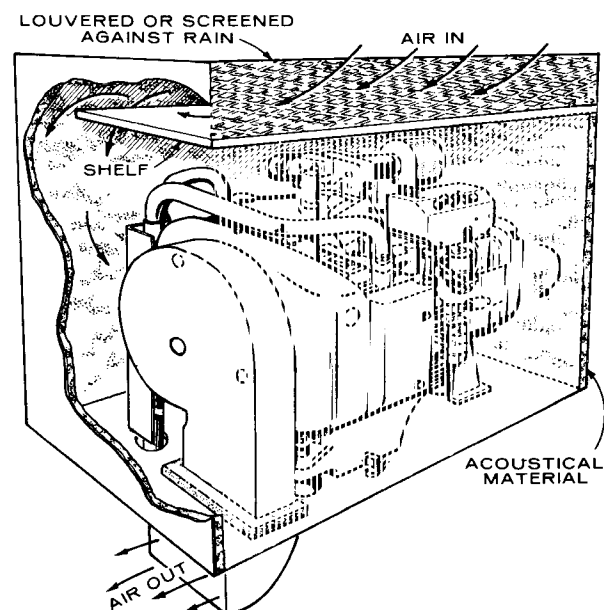
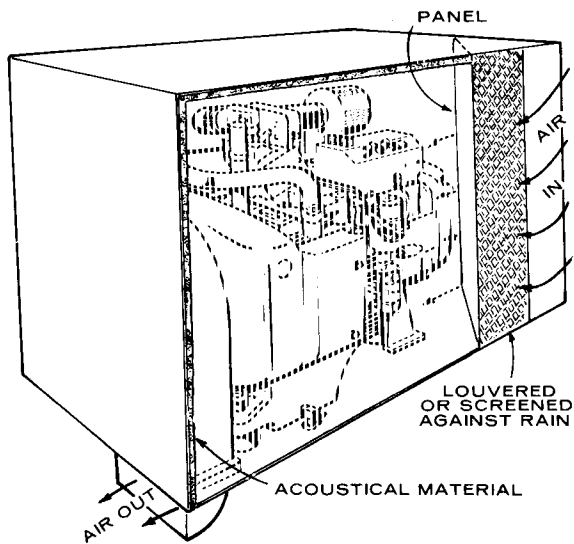

FIGURE 6. SHELF-CONCEPT COMPARTMENT

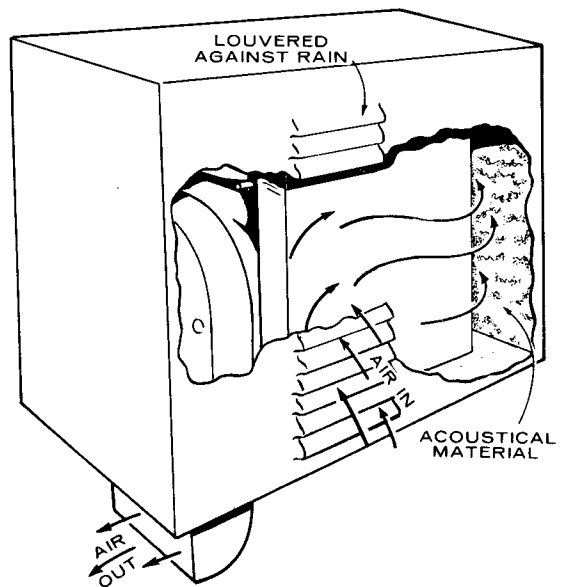

**FIGURE 7. PANEL-CONCEPT COMPARTMENT**

side of the duct and acoustical material, where applicable. Acoustical material lining inside the duct, if used, must not restrict airflow.

**Air Outlet Duct**

Noise of discharged air from the compartment can be



**FIGURE 8. Z-DUCT CONCEPT COMPARTMENT**

reduced by adding a duct (Figures 5 through 8) to direct the airflow under the vehicle. For most effective acoustical treatment, line the duct with acoustical material which is resistant to oil or gas absorption, and is fire resistant. Ducting or acoustical treatment material must not restrict discharge airflow from the set.

# Fuel System

All Onan AC electric generating sets for recreational vehicles use gasoline fuel. Because any AC generator set runs at a constant speed, lead deposits tend to build up in the combustion chambers. For this reason, use clean, fresh, no lead or low-lead gasoline. Regular grade gasoline may also be used, but DO NOT use highly leaded premium types of fuel.

For new engines, the most satisfactory results are obtained by using unleaded gasoline. For older engines that have previously used leaded gasoline, the cylinder heads must be taken off and all lead deposits removed from engine before switching to unleaded gasoline.

**CAUTION** Lead deposits must be removed from an engine before switching from leaded to unleaded gasoline. If not, preignition can occur causing engine damage.

Most Onan recreational vehicle gasoline generator sets have electric fuel pumps as standard. The other recreational vehicle models have mechanical fuel pumps. Choice of fuel pump type used is primarily for prevention of vapor lock.

**WARNING** Leakage of gasoline in or around the compartment is a definite hazard. The ventilation system should provide a constant flow of air to expel any accumulation of fuel vapor while the vehicle is in transit. Compartments must be vapor tight to the interior to keep fumes from within the vehicle.

## Gaseous Fuel

This fuel does have some advantages over gasoline, but Onan does not use (on AC RV models) and does not recommend gaseous fuel operation for the following reasons:

1. Complex installation—requires special lines, solenoid valve, strainer, regulators, gauges, etc.
2. High installation costs.
3. Usually limited bulk fuel availability.
4. Set capacity limited by physical size of tanks.
5. Lower engine power.
6. Poor and erratic low temperature starting and operation.

## FUEL CONSUMPTION

It should be noted that under varying electrical loads, engines for recreational vehicle generator sets can use up to the fuel consumption figures shown in Table 6 for rated output.

TABLE 6. FUEL CONSUMPTION

MOBILE UNIT	GALLONS/HOUR (at rated load)
2.5LK	0.52
2.7AJ	0.54
4.0CCK	0.88
4.0BF-3CR	0.88
4.0BF-1R	0.88
5.0CCK	1.05
6.0NH	1.05
6.5NH	1.30

If the vehicle fuel tank is shared, design the fuel tank withdrawal system to insure the set cannot use the entire supply. See *Sharing Fuel Tank Supply* following.

## SHARING FUEL TANK SUPPLY

Most electric generating set installations are designed to share the vehicle fuel supply tank with the vehicle engine. All connections to vehicle fuel system must be in accordance with chassis (vehicle) manufacturers' detailed installation instructions.

## FUEL LINES AND FUEL FILTERS

### Fuel Lines

1. Use seamless steel tubing and flared connections.
2. Run fuel lines at the top level of tank to a point as close to the engine as possible to reduce danger of fuel siphoning out of tank if the line should break.
3. Keep fuel lines away from hot engine or exhaust areas. This reduces chance of vapor lock.
4. Line must be long enough to prevent binding or stretching because of set movement.
5. Install an approved flexible nonmetallic and non-organic fuel line between the solid fuel line and engine to absorb vibration.
6. Install lines so they are accessible and protected from damage.
7. Use nonferrous metal straps without sharp edges to secure the fuel lines.

### Fuel Filters

Onan electric generating sets with electric fuel pumps have phenolic or screen filters within the fuel pump itself. Additional filters in the fuel line are unnecessary unless unusual operating conditions exist.

Operating the generator set from a tee in the main fuel line can cause erratic operation. The set's fuel pump has neither the capacity nor the power to overcome the draw of vehicle engine fuel pump.

## **FUEL SOLENOID**

The positive fuel shutoff valve prevents flooding of the generator set, when not in use, should the vehicle fuel tank become pressurized.

## **GASOLINE EVAPORATIVE CONTROL SYSTEMS**

With the increasing emphasis on pollution controls, certain states are now requiring strict evaporative controls on vehicle gasoline supply systems. Manufacturers of RV chassis and vehicles in general have complied to new regulations for these areas by using special design gas tanks, filler tubes, filler gas caps and interconnecting vapor tubing from the vehicle gas tank through a special canister to the vehicle engine.

Because these systems are designed to operate in a critical pressure range, it is very important during connection of an electric generating set and building of the motor home, etc., the vehicle manufacturer's fuel supply design not be altered. The filler tube, fill limiter vent, canister, vapor lines and gas fill cap should not be changed, removed or replaced unless receiving recommendations and approval from the vehicle manufacturer. If not, serious vehicle engine and generator set operating conditions could result. Always check the filler gas cap to make sure it has a pressure and vacuum relief valve. Also check to make sure it works.

Because various designs of such systems exist, Figure 9 shows a typical gasoline evaporative control system. By checking the vehicle chassis for a canister, vapor lines, etc., you should be able to identify whether or not it has an evaporative control system.

**If operating problems develop due to the fuel system, check the fill cap to make sure the vacuum and pressure relief valve is working properly.**

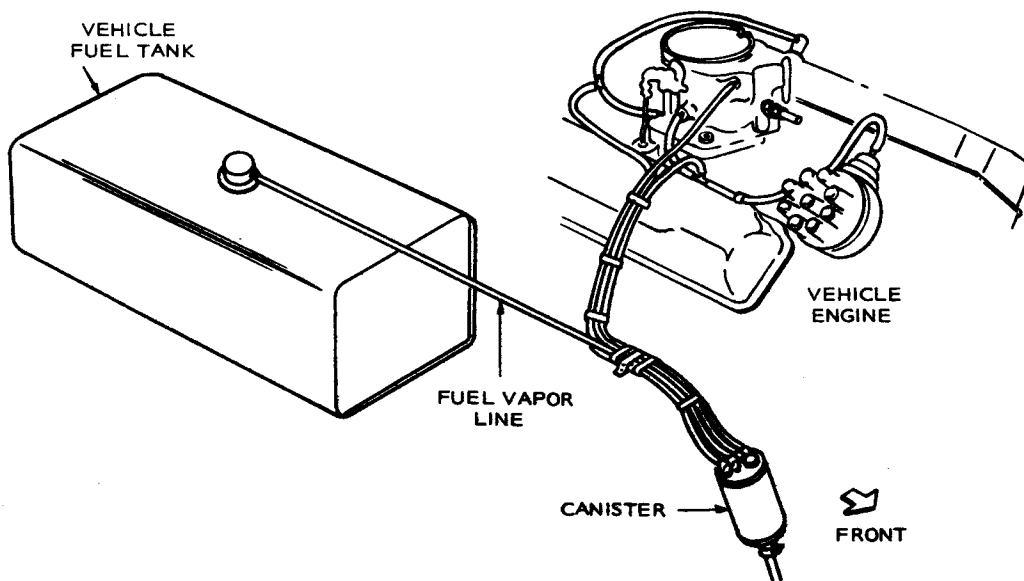

**FIGURE 9. TYPICAL EVAPORATIVE CONTROL SYSTEM**

**WARNING**

**ENGINE EXHAUST GAS (CARBON MONOXIDE) IS DEADLY!**

Carbon monoxide is an odorless, colorless gas formed by incomplete combustion of hydrocarbon fuels. Carbon monoxide is a dangerous gas that can cause unconsciousness and is potentially lethal. Some of the symptoms or signs of carbon monoxide inhalation are:

- Dizziness
- Intense Headache
- Weakness and Sleepiness
- Vomiting
- Muscular Twitching
- Throbbing in Temples

If you experience any of the above symptoms, get out into fresh air immediately.

The best protection against carbon monoxide inhalation is a regular inspection of the complete exhaust system. If you notice a change in the sound or appearance of exhaust system, shut the unit down immediately and have it inspected and repaired at once by a competent mechanic.

# Exhaust System

Plan each individual exhaust system carefully. A good installation not only is gas tight, but usually quieter, too. Be sure to check all applicable recreational vehicle standards, local codes and regulations.

## WARNING

Plan the exhaust system carefully. Exhaust gases are deadly!

## CAUTION

Do not connect the generator set exhaust to the vehicle exhaust system. Water vapor from one engine can damage the other engine.

1. Where the exhaust system passes through the base or floor, leave adequate clearance as protection against exhaust pipe damage from vibration (Figure 10).
2. The exhaust system must be no closer than six inches from any combustible material; or, be so located, insulated or shielded so it does not raise the temperature of any combustible material by more than 117 F degrees above the ambient air inlet temperature after the generator set has run at full load for one hour.
3. The exhaust system must terminate aft of the generator set compartment and extend to the perimeter of vehicle.

## WARNING

Do not terminate exhaust under vehicle, as carbon monoxide gas is poisonous. Direct exhaust gases away from window and door openings.

4. Exhaust pipe must terminate a minimum of three feet from the vehicle gasoline filler spout (more distance if required by local codes).
5. Use the largest possible radius elbows on the exhaust lines and as few elbows as possible. If not, the system might create high back pressure.
6. Use automotive type tail pipe hangers for hanging the exhaust system from vehicle undercarriage.

## CAUTION

If tail pipe deflector is used, be sure it is large enough to prevent excessive back pressure.

## EXHAUST SPARK ARRESTERS

Exhaust spark arresters are necessary when operating in some parks and camps. Two basic types are used in the recreation vehicle industry. One is a

**IMPORTANT:** Certain states (particularly California) have state ordinances pertaining to the type and usage of exhaust muffler/spark arresters on internal combustion engines or engine driven equipment when used in a recreational vehicle such as electric generating sets. Be sure your installation meets all Federal, State and local codes pertaining to your unit. Failure to provide and maintain a spark arrester may be in violation of the law.

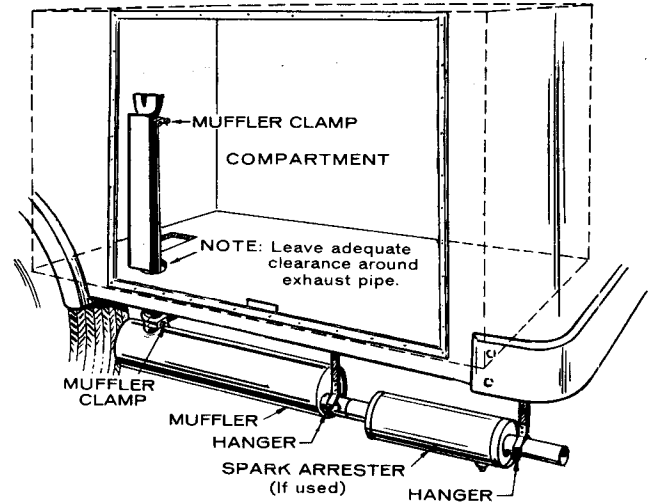

FIGURE 10. TYPICAL EXHAUST SYSTEM INSTALLATION

spin-out type spark arrester, the other is a screen type spark arrester. All require periodic clean-out (every 50 to 100 operating hours) to maintain maximum efficiency.

## Spin-Out Type Spark Arrester

This type removes carbon particles by centrifugal force, catching the particles in a holding chamber. Removing a pipe plug from the arrester and operating the generator set (at a convenient time and place) cleans out the deposits. It is important to note this arrester does not plug up when the holding chamber is full and does not cause harmful, high exhaust back pressure. When full, particles pass through the arrester.

## Screen Type Spark Arrester

This arrester has a screen which traps carbon particles as they pass through. The screen is removed, cleaned or replaced after it has filled. A disadvantage of this type is the screen plugs as it collects the particles and gradually increases exhaust back pressure. Back pressure causes a loss of engine power and can cause burned or damaged valves if pressure is high enough. It is very important this type be cleaned as recommended.

## WARNING

On all listed models with exhaust shielding supplied with unit, shielding **MUST** be properly installed to prevent overheating of compartment walls or the possibility of fire. Refer to appropriate installation guide for each model for details.

# Electrical Loads and Connections

All of the following description pertains to alternating current Onan electric generating sets for recreational vehicles.

1. All wiring must meet applicable local electrical codes. Have a qualified electrician install and inspect the wiring.
2. Wires must be adequate size, properly insulated and supported in an approved manner.
3. Mount switches and controls securely to prevent damage from vibration and road shocks. All switches must be vibration-proof to prevent accidental opening or closing while the vehicle is in motion.
4. Install an approved junction box for feeder conductors from the electric generating set. It must have a blank cover and be inside compartment (not on set).

**WARNING** To prevent noxious gases from entering vehicle interior, seal any openings made in the set's compartment for conduit, wiring, etc.

## WIRE TYPES

Use multistrand wire which meets all applicable codes as feeder conductors, from electric generating set to compartment junction box. Many installers use multistrand wire throughout the vehicle to reduce the danger of breakage from vibration.

The generator set conductors must be able to carry at least 115 percent of the generator nameplate current (amperes). Neutral conductors must be the same size as the conductors of the outside legs.

Supply conductors from the electric generating set to the junction box on the compartment wall must be installed in flexible conduit.

**CAUTION** Do not use solid metal conductors in compartment. They may develop metal fatigue from set movement and eventually break.

**WARNING** Because of fire hazard, do not tie electrical wiring to fuel line.

## DISCONNECT SWITCH

The feeder conductors from the set compartment must terminate in a double-pole, double-throw positive off switch device for 120 volt operation before the vehicle distribution panel. This assures the outside power source cannot be connected simultaneously with the electric generating set. For

120/240 volt operation, a 3-pole, double-throw, positive off, switching device must be used. Neutral must be switched.

## RECOMMENDED TRANSFER MECHANISMS

An economical manual, positive-off transfer mechanism is a receptacle for the generator set in the compartment. An approved power cable connected from the load, plugs into this receptacle or the park utility power receptacle. This ensures both sources are NOT connected simultaneously.

An alternative to the receptacle is a manual, positive-off type transfer switch. The positive-off switch allows residual voltages of inductive loads (motors, etc.) to decay before switching to the other power source.

**WARNING** Use only approved power supply assemblies. Never remove grounding pin from power supply assembly. Incorrect or no ground may cause the recreational vehicle to be electrically "hot."

## RECONNECTIBLE, SINGLE-PHASE GENERATOR

Voltage selection on reconnectible single-phase generators is for use as 120/240 volts, 3 wire; or 120 volts, 2 wire. Use the connection for two wire service when used for motor starting such as air conditioning. Balance the load when connecting for three wire service. Current for any one output lead must not exceed nameplate rating. When two or more single-phase circuits are available, divide the load equally among them. See Figure 12.

## LOAD CONNECTIONS

Generator set load wires M1, M2, M3 and M4 terminate within the junction box. Connect and join wires within junction box in an approved manner for desired voltage code. See Figure 12.

On motor homes which have provisions for using outside AC utility power (separate from the electric generating set) the neutral as well as the "Hot" lead MUST be completely isolated from the motor home when load or power is switched.



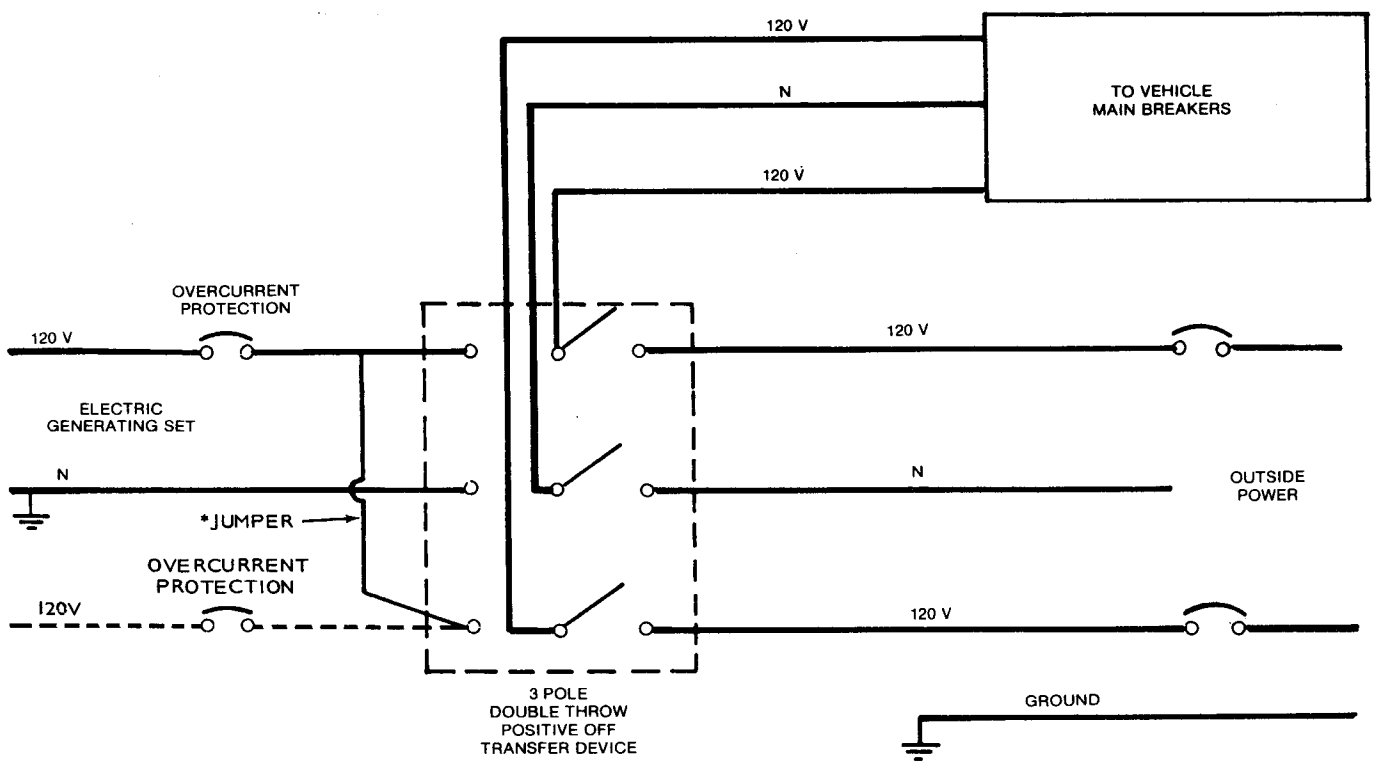
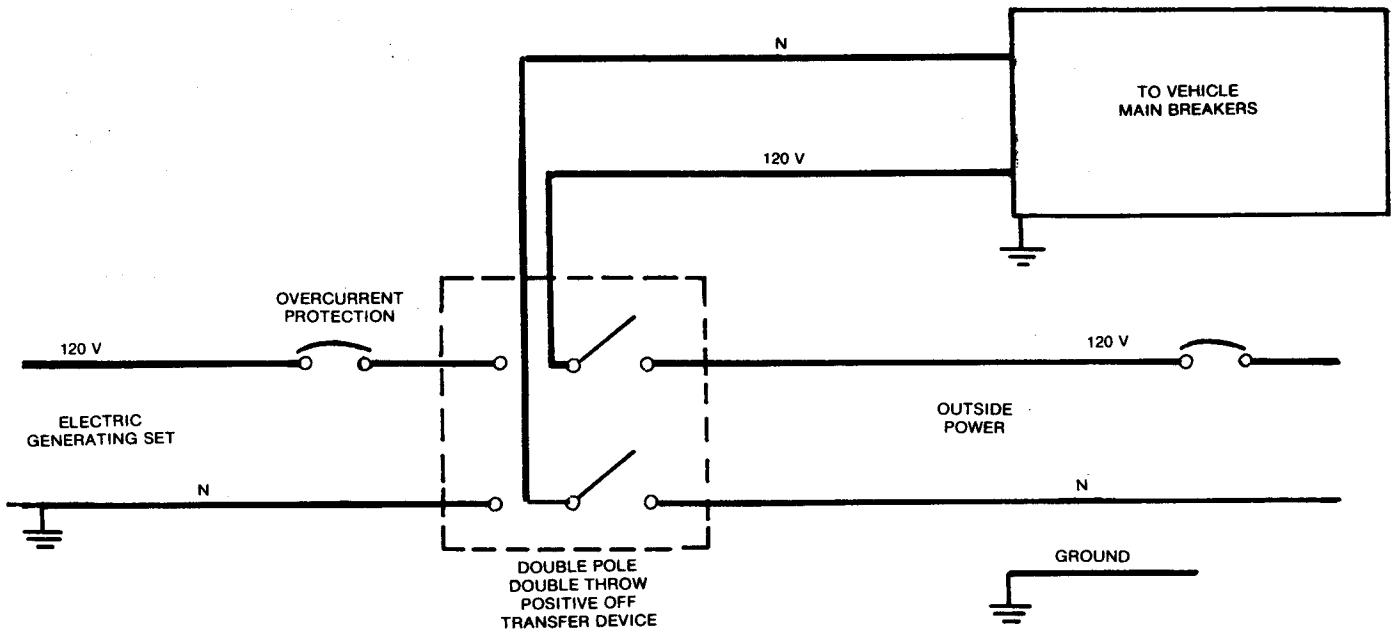

\*FOR 120/240 OPERATION DO NOT USE JUMPER. CONNECT OVERCURRENT PROTECTION AS SHOWN IN DASHED LINE. SEE RECONNECTION DIAGRAM: FIG. 12

Figure 11. SCHEMATIC OF TRANSFER DEVICE AND OVERLOAD PROTECTION

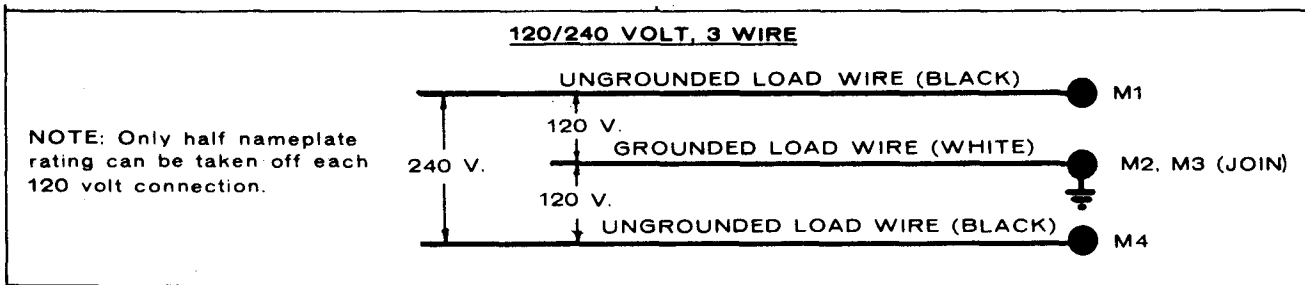
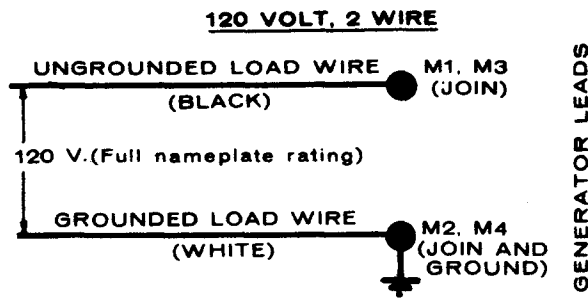

**FIGURE 12. SINGLE-PHASE, "3C" VOLTAGE CODE GENERATOR CONNECTIONS**

The operation of a typical transfer device is shown in Figure 11. In addition to the transfer device, an over current protection device (circuit breaker or fuse) shall be provided between the transfer device and the AC circuit in the motor home. The generator set field has inherent overload protection when any overload is applied; frequency will sag which causes output voltage to drop and in turn the generator set field drops to zero voltage. A ground fault circuit interrupter should be installed in the wiring system to protect all branch circuits.

**WARNING** Use only approved power supply assemblies. Never remove grounding pin from power supply assembly. Incorrect or no ground may cause the recreational vehicle to be electrically "hot."

### STARTING CONTROLS

Remote control Onan electric sets are designated by an "R" in the model number and provide the operator to start the set inside the vehicle, etc. Sets with the designation "E" are electric start at the set only. See the appropriate operator's manual for more specific information.

Onan has available remote start-stop controls for the AJ, LK, BF, CCK and NH electric generating sets. An Onan remote control switch shown in Figure 13 includes a start-stop switch with an amber indicator lamp (lights when set is running). A deluxe remote control includes a start-stop switch with an amber indicator lamp (lights when set is running), a running time meter and a battery condition meter. See Figure 14

**FRONT SIDE OF REMOTE CONTROL SWITCH**

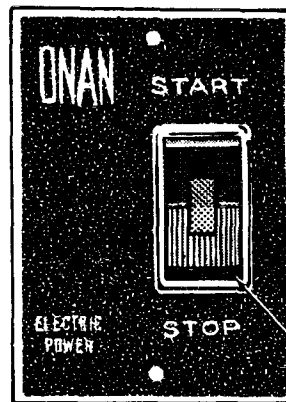

**NOTE:** Use 18 gauge or larger wire for installing the remote start switch.

**STOP-START SWITCH (DPDT)**  
(Amber light glows when generator set is running)

**FIGURE 13 OPTIONAL REMOTE CONTROL SWITCH**

### FINAL CHECK-OUT PROCEDURE (60 to 80 F ambient)

Before the generator set is operated, remove the spark plug wires so the set will not start when cranked. Connect a voltmeter to the battery terminals, and to the battery side of the start solenoid and set frame as shown in Figure 15.

Crank the engine and measure the voltage at the

battery. Then measure the voltage from the start solenoid to the set frame. Do not allow more than five seconds between these readings (use double-pole, double-throw switch as shown).

Subtract voltage at set from measured battery voltage during the cranking. The difference should not exceed 0.6 volt. If it does, check all connections. A separate ground cable may have to be used (same size as battery cable).

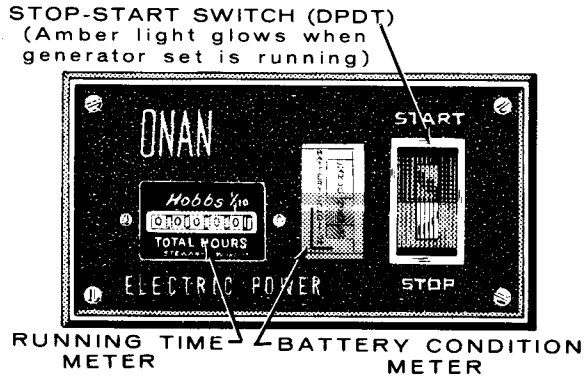

### Alternate Test

Remove the spark plug wires, crank the engine and measure the cranking speed. Connect a separate ground cable from the battery to the set's frame. Crank the engine and again measure the speed. If cranking speed increased more than ten percent, check connections and consider a permanent ground cable if it seems necessary.

FIGURE 14. OPTIONAL DELUXE REMOTE CONTROL

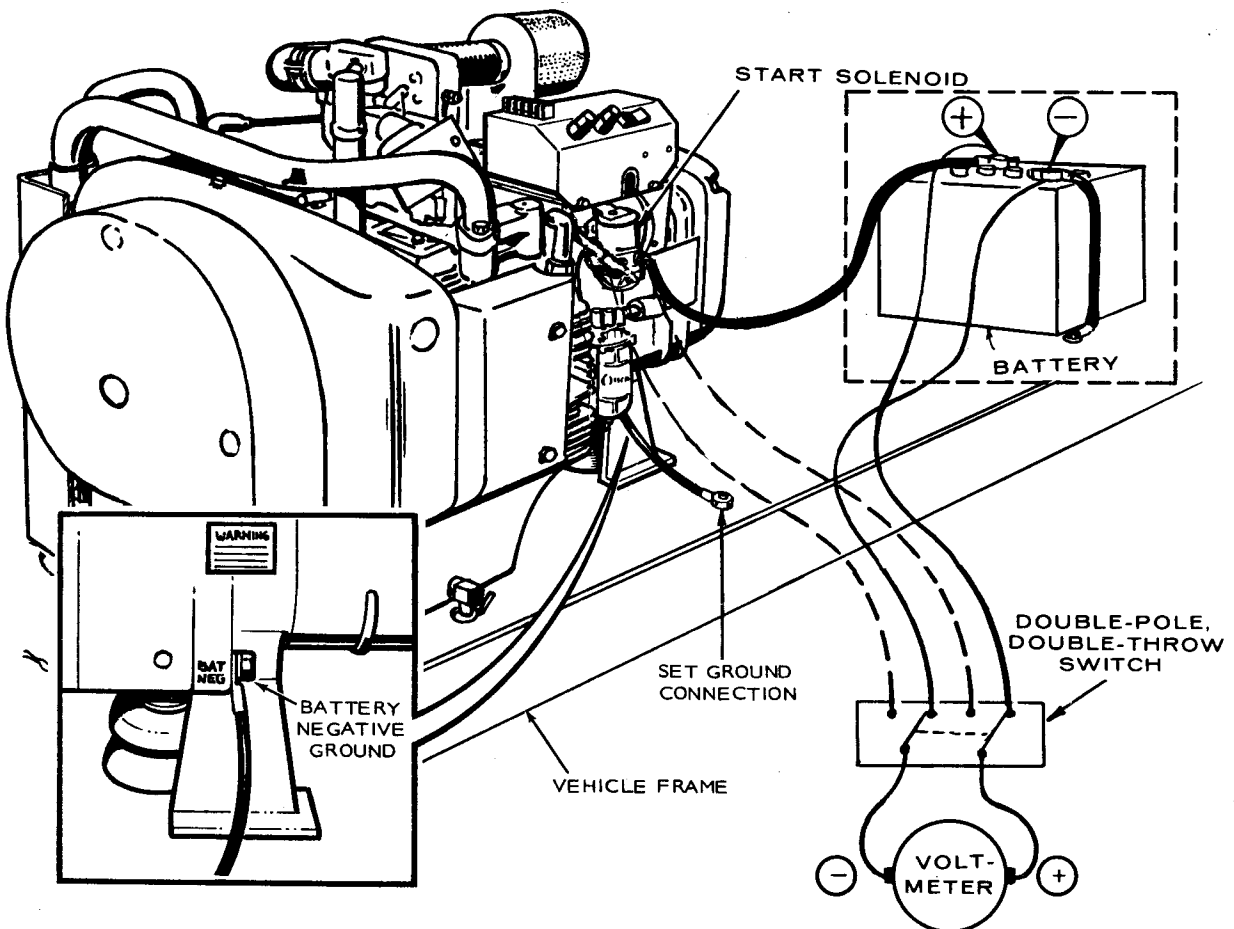

FIGURE 15. BATTERY SYSTEM CHECK-OUT CONNECTIONS

# Batteries

## BATTERY CARE

To increase battery life, the operator can perform a number of routine checks and some preventive maintenance.

1. Keep the battery case clean and dry.
2. Make sure the battery cable connections are clean and tight. Use a terminal puller when removing cables for any reason.
3. Coat the battery terminals with a mineral grease or petroleum jelly to reduce corrosion and oxidation.
4. Identify each battery cable to be positive or negative before making any connection. Always connect the ground (negative) cable last.
5. Maintain the electrolyte level by adding water (drinking quality or better) as needed for filling to split level marker. (The water ingredient of the electrolyte evaporates, but the sulphuric acid ingredient remains. Therefore, add water, not electrolyte.)
6. Avoid overcharging when recharging. Stop the boost charge when the specific gravity is 1.260 and the electrolyte is 80°F (26.7°C).

### WARNING

Do NOT use unvented batteries with this generator set. Malfunction of the starting-charging system can produce high charging currents, causing excessive gassing. An unvented battery can build up sufficient pressure to explode.

## BATTERIES AND BATTERY CABLES

In order for the electric generating set to crank efficiently under various operating conditions, the battery and battery cables must be correctly chosen and installed. Before selecting a battery, be sure the installation area is compatible and properly designed. The compartment for the battery must provide:

1. Rigid mounting support.
2. A location where accidental acid spills or leaks won't damage set, battery cables, etc.
3. Provide a minimum of 2 square inches at top and 2 square inches at bottom of battery for ventilation purposes.

### WARNING

Do not disconnect battery cables from battery while generator set is cranking or running; sparks may cause an explosion.

### WARNING

Mount the battery in a separate compartment from the set or any spark-producing device to prevent fire or explosion.



Never disconnect the battery with either engine running and never crank both engines simultaneously.

## Battery Cables

For reliable starting, voltage drop from the battery terminals to the exciter cranking windings of the generator should not exceed 0.12 volts per 100 amperes of break-away current. The battery cables in Table 7 will meet this condition if the grounding system is adequate. Connect the battery negative to ground with the same size cable as used for battery positive.

Be sure the frame connection (major frame member if possible) is sufficient to minimize resistance. Try to avoid a connection at a weld or mechanical joint.

For short distances, one negative battery cable can be used between set and battery rather than separate cables to chassis ground.

## Battery Selection

Determine battery size by the amount of "surge" power required to start the generating set. Select a battery that is at least as large as that specified by Onan.

Locate battery as close as possible to starter and charging system. Keep the battery well charged and clean. Keep terminals clean and free of corrosion.

## Battery Size

Onan recommends one 12-volt, 74 amp hour battery for all RV generator sets. In colder temperature applications (0° to 32°F), one 12-volt, 92 amp hour battery is recommended for all units. For sub-zero operation, Onan recommends one 12-volt, 105 amp or larger capacity battery.

TABLE 7.  
RECOMMENDED BATTERY CABLES

* CABLE LENGTH IN FEET (metres)	CABLE SIZE
0-10 (0-3)	2
11-15 (3-4.5)	0
16-20 (4.5-6)	000

\* - Distance from battery to set.

# Remote Accessories

## INSTALLING STANDARD REMOTE CONTROL

This control includes a start-stop switch with an indicator lamp. Install as follows:

1. Select switch location. Using Figure 16 as a guide, drill screw holes and cut holes in RV panel.
2. Following national and local electrical codes and using four insulated wires of predetermined length (#18 or larger), connect remote switch to terminals on generator. See Figure 17.

**CAUTION** Ensure that leads from remote switch connect with corresponding terminals on generator terminal board.

**CAUTION** Don't route DC wires for remote control through conduit containing AC load wiring. Induced voltages may cause erratic operation.

3. Insert remote switch in hole cutout and secure with two #5 woodscrews supplied with switch.

**WARNING** Seal all holes that might allow noxious gases from generator set into motor home.

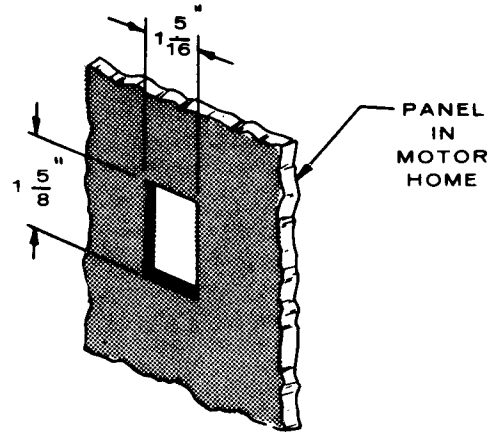

FIGURE 16. MOTOR HOME CUTOUT

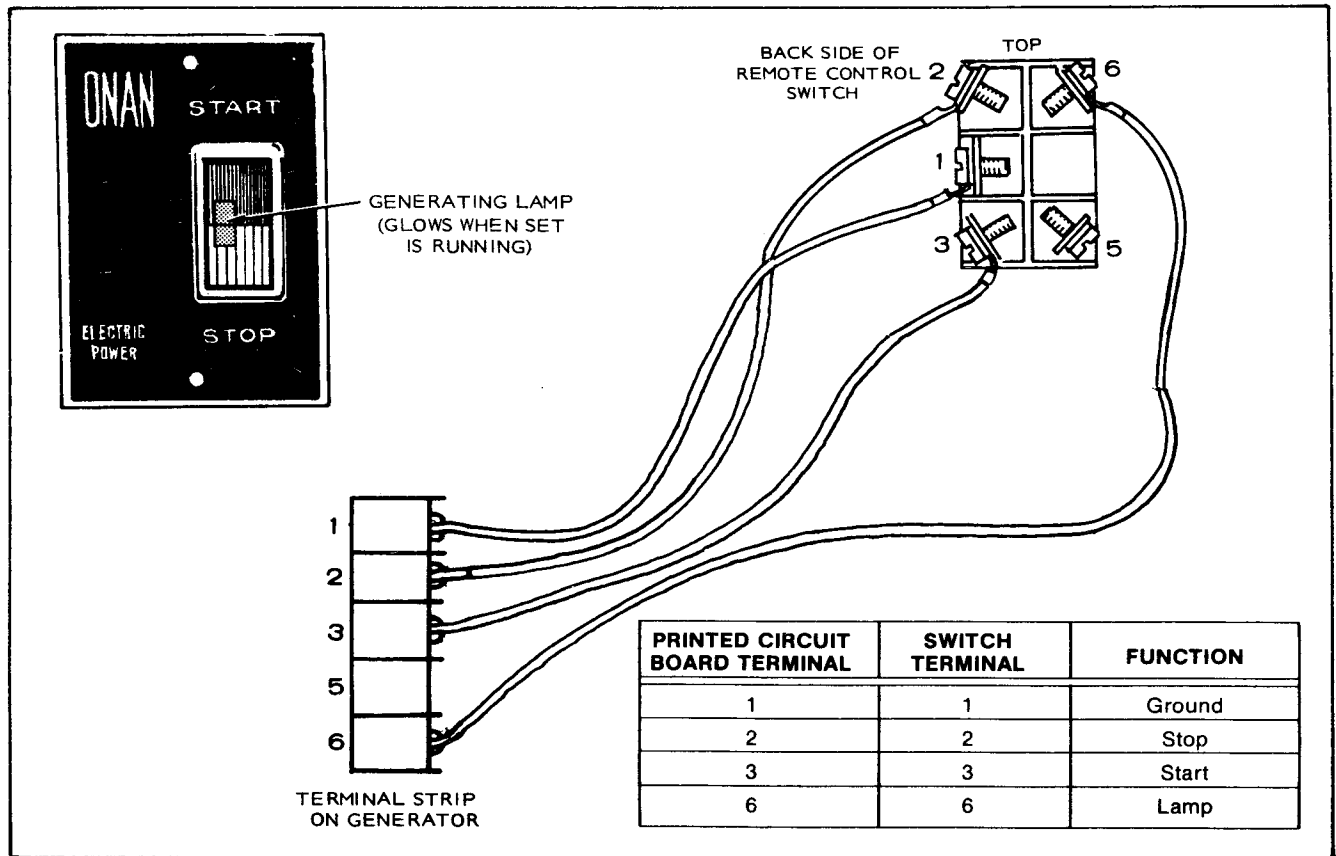

FIGURE 17. CONNECTING REMOTE CONTROL (300-0985)

## INSTALLING DELUXE REMOTE CONTROL

This control includes a start-stop switch with an indicator lamp, a running time meter and a battery condition meter. Install and connect as follows:

1. Select control location. Using Figure 18 as a guide, drill screw holes and cut hole to accommodate remote switch in panel.
2. Following national and local electrical codes and using five insulated wires of predetermined length (#18 or larger), connect remote control to terminals on generator. Ensure that leads from remote control connect to corresponding terminals on generator terminal board. See Figure 19.

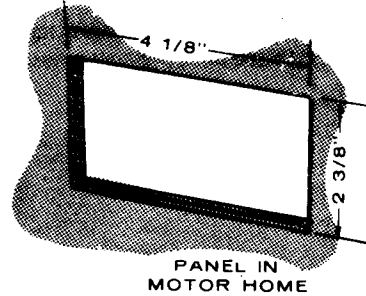

FIGURE 18. MOTOR HOME CUTOUT

**CAUTION** Don't route DC wires for remote control through conduit containing AC load wiring. Induced voltages may cause erratic operation.

3. Insert remote control in hole cutout and secure with four #5 woodscrews supplied with switch.

**WARNING** Seal all holes that might allow noxious gases to enter motor home.

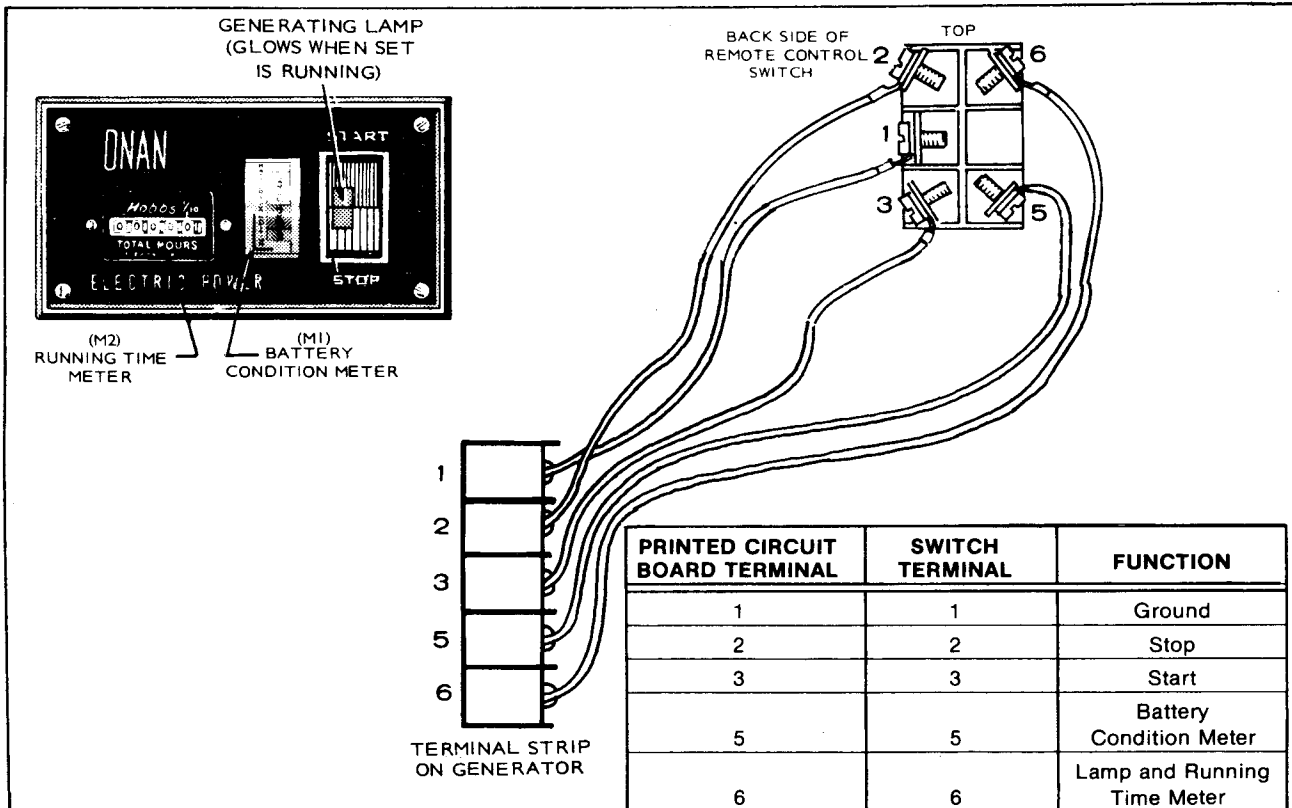

FIGURE 19. CONNECTING DELUXE REMOTE CONTROL (300-0986)

# Pre-Start Checks

The RV unit is complete as received except for exhaust components and any other optional accessory items which are shipped loose with each set for installation later. After the initial installation is completed, the following steps are necessary before actually starting the generator set for the first time.

1. Install the exhaust system.
2. Add oil to the engine.
3. Connect fuel line to engine from fuel supply tank.
4. Connect electrical leads to load circuits.
5. Connect the start stop remote switches (if used).
6. Connect battery leads between set and battery. Connect ground lead last.

**Vehicle chassis (frame) ground and the battery and generator set ground should all be electrically connected to be at 0 ground potential. All Onan units are designed for negative ground application.**

## FUEL SYSTEM

With set running, check for leaks. Raw fuel will cause

fumes which could EXPLODE. Check around carburetor and fuel pump inlets. Make sure fuel lines are not rubbing against anything which could cause breakage.

## ELECTRICAL

### AC Output

All AC leads (M1, M2, M3 and M4) terminate in generator set's junction box. These wires should be connected to distribution box with multistrand wire enclosed in a flexible conduit. Check all wires (to and from the generator set) for fraying and loose connections.

### Battery Connections

Battery positive (+) connects to start solenoid. Battery negative (-) connects to location on rear of generator. Check terminals on set for clean and tight connections.

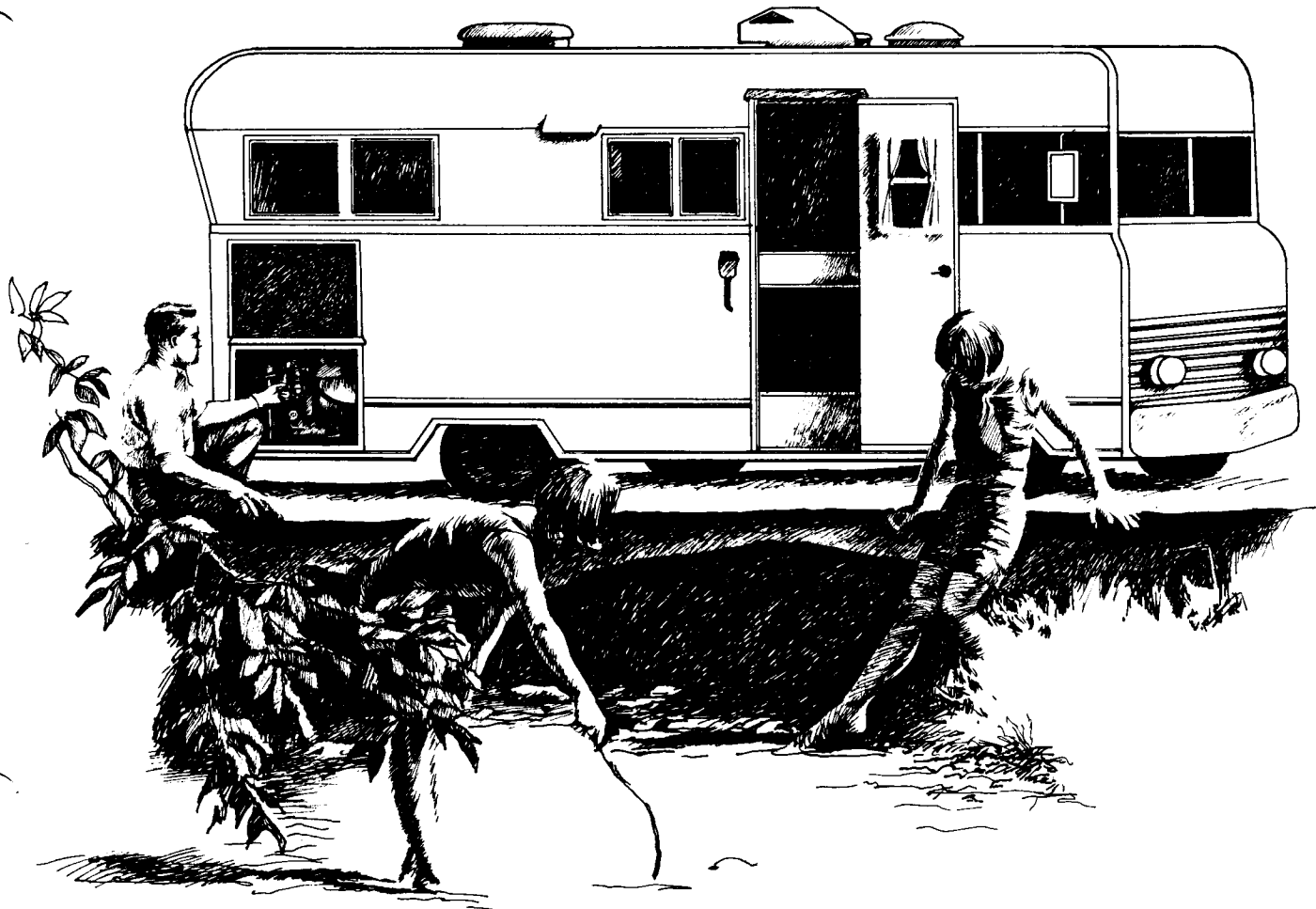

### WHAT IS A GOOD INSTALLATION?

An owner of an RV electric generating set considers his unit well installed if it produces electricity quietly, reliably and efficiently.

But how do you — the installer — provide a good installation? Here are some guidelines:

The electric generating set should be mounted on vibration isolators and the isolators, in turn, firmly mounted to a strong base. The fuel and electrical lines should be mounted to the frame and connected to the unit through flexible sections. Exhaust system components must be installed with good automotive practice.

Cooling is important. All good RV installations call for a well-ventilated generator compartment (see section on *Ventilation*), one that cools adequately while running and completely purges heated air after shutdown.

A good installation must also be fireproof and vapor-proof. This bulletin tells how to accomplish this . . . read it carefully.

Our recommendations for the proper installation of an RV electric generating set are based on years of experience in the manufacture of generator sets. We offer these recommendations through this technical bulletin so you can be assured the Onan unit selected for your recreational vehicle will operate quietly and efficiently for many years to come.



# © 2006 UsefulCDs



**Onan manufactures a complete line of electric power systems from 1 to 750 kW (generator sets • automatic transfer switches • industrial engines), gas-, gasoline- or diesel-driven. For standby power in homes, industrial plants, commercial buildings and institutions. For auxiliary or portable power in boats, recreational vehicles, service trucks and construction equipment.**

