

# Training Manual

## Fast-Response™ II Standby Generator Sets

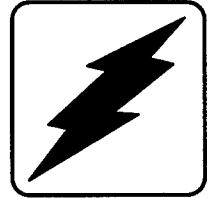

**Models:**  
20-300 kW

**KOHLER**<sup>®</sup>  
POWER SYSTEMS

Insert only G23-26  
Binder only 221907

TP-5706 7/97

## TABLE OF CONTENTS

SUBJECT	PAGE	SUBJECT	PAGE
INTRODUCTION.....	i	MICROPROCESSOR CIRCUIT BOARD (DEC 3)C12	
SAFETY PRECAUTIONS.....	ii	TB1 TERMINAL STRIP (DEC 3).....	C12a
FAST RESPONSE .....	iii	Remote start/stop.....	C12a
ALTERNATOR DESIGN BASICS.....	iv	Emergency Stop .....	C12a
FIELD EXCITATION DESIGNS.....	v	Crank mode .....	C12a
FAST RESPONSE DESIGN.....	vii	TB1 TERMINAL STRIP.....	C13
<b>ALTERNATOR ASSEMBLY</b>		Indicator output terminals..	C13a
FRI ALTERNATOR COMPONENTS .....	A1	SPEED SENSOR ..	C13
FRII ALTERNATOR COMPONENTS .....	A2	Overcrank .....	C13
STATOR CODE SIZE .....	A3	Overspeed .....	C13
STATOR WINDING CONNECTIONS.....	A4	Locked Rotor.....	C13
STATOR LOAD BALANCE .....	A5	CIRCUIT BOARD CONNECTORS (DEC 3).....	C14
STATOR INSULATION .....	A6	CIRCUIT BOARD RELAYS & FUSES ..	C15
STATOR RESISTANCE.....	A7	Diagram, relay & fuses .....	C15
EXCITER FIELD (PM).....	A8	DIAGRAM - FR System, Schematic (DEC 3).....	C16
ROTOR - Main Field.....	A9	DIAGRAM - FR System, Line (DEC 3).....	C16a
EXCITER ARMATURE.....	A10	MICROPROCESSOR CIRCUIT BOARD (DEC 3+)C17	
SCR MODULE .....	A11	TB1 TERMINAL STRIP (DEC 3+).....	C17a
PHOTO TRANSISTOR BOARD .....	A12	Output terminals .....	C18
LED BOARD .....	A13	Remote start/stop.....	C18a
VOLTAGE REGULATOR .....	A14	Crank Mode .....	C18a
GENERATOR ENCLOSURE.....	A15	Prime Power mode.....	C18a
SAFEGUARD BREAKER TERMINAL STRIP.....	A18	CIRCUIT BOARD CONNECTORS (DEC 3+).....	C19
CURRENT TRANSFORMERS (CT).....	A19	CIRCUIT BOARD FUSES AND RELAYS (DEC 3+)C20	
AUXILIARY RELAYS .....	A21	Overvoltage shutdown .....	C20a
Governor relay K5.....	A21	CIRCUIT DIAGRAM (DEC 3+).....	C21
Air Damper Relay K6.....	A21	CIRCUIT BOARD (DEC 1).....	C25a
<b>CONTROLLER</b>		CIRCUIT DIAGRAM (DEC 1) .....	C26
CONTROLLER CABINETS .....	C1	CIRCUIT BOARDS (Decision-Maker™340) C30 -C34	
Manual Controller .....	C1a, C22	<b>ACCESSORIES &amp; OPTIONS</b>	
7 Light microcomputer.....	C1a, C23	LINE CIRCUIT BREAKER .....	A16
16 Light microcomputer .....	C1a	Thermal trip.....	A16
16 Light microcomputer, expanded.....	C1a	Magnetic trip .....	A16
Paralleling engine gauge box.....	C1a	Shunt trip .....	A16a
DEC 1 Controller .....	C1a, C24	Thermal Magnetic .....	A16a
Decision-Maker™340.....	C27 - C29	SAFEGUARD BREAKER .....	A17
AC METERS .....	C2	REACTIVE DROOP COMPENSATOR .....	A20
Wattmeter.....	C2a	RUN RELAY .....	A22
METER SELECTOR SWITCH .....	C3	CUSTOMER CONNECTION TERMINAL STRIP .....	A23
Meter scale indicators.....	C3a	OVERVOLTAGE KIT (DEC 3) .....	AC1
Meter terminal strip and fuses .....	C3a	REMOTE EMERGENCY STOP SW. (Break glass)AC2	
EMERGENCY STOP SWITCH.....	C4	AUDIO/VISUAL ALARM KIT .....	AC4
VOLTAGE ADJUST RHEOSTAT .....	C5	COMMON FAULT RELAY KIT .....	AC5
HOURLMETER .....	C5	1 RELAY DRY CONTACT KIT .....	AC6
PANEL LAMPS .....	C5	10 RELAY DRY CONTACT KIT .....	AC7
ENGINE GAUGES & SENDERS.....	C6	14 RELAY DRY CONTACT KIT .....	AC8
Oil temp .....	C6a	REMOTE ANNUNCIATOR PANEL .....	AC9
Tachometer .....	C6a	Fault indicators..	AC9
CONTROL STATUS INDICATOR PANEL.....	C7	REMOTE ANNUNCIATOR PANEL.....	AC10
Control switch, Run-Off/Reset/Auto ..	C7	Interconnection ..	AC10
Lamp Test Switch.....	C7	DIAGRAM - Accessory connections .....	AC11
Alarm Horn .....	C7	DIAGRAM - Accessory interconnections .....	AC12
Alarm Silence Switch.....	C7	OVER/UNDER FREQUENCY MODULE .....	AC13
Plug connectors .....	C7a	ENGINE MANAGEMENT MODULE .....	AC13
STATUS PANEL INDICATORS.....	C8	<b>GLOSSARY - .....</b>	
Engine temp./ pressure senders.....	C8	G1	
DIAGRAM, DEC 3+ Fault indicator senders .....	C9		
DEC 3 Fault indicator senders.....	C9a		

## INTRODUCTION

This manual covers operation and features of KOHLER FAST RESPONSE Generator sets.

It is only intended as a training guide and does not necessarily contain all available service information.

Pictures, Illustrations and wiring diagrams in this manual are only representative of the various models and may differ slightly even within the same model designation series.

This manual is not to be used as an installation manual.

For complete service, parts, and installation information the following manuals are available from Kohler Co. Generator Division, Service Parts Department.

## FR GENERATOR SET MANUALS

TP-5044 - FAST RESPONSE SERVICE MANUAL (Early FR Generators w/mother-daughter board and uniboard controller.)

TP-5149 - FR II GENERATOR SERVICE MANUAL (Early FR II Generators with Dec II Controllers)

TP-5262 - FR II GENERATOR SERVICE MANUAL (FR II Generators with Relay Controllers, DEC 3 controllers and split activators.)

TP-5353 - FR II GENERATOR SERVICE MANUAL (FR II Generators with DEC 3 Enhanced controller.)

TP-5823 - Decision-Maker™ 340 SOFTWARE OPERATION

TP-5829 - Decision-Maker™ 340 OPERATION

TP-5051 - Parts list - FAST RESPONSE GENERATORS. (Early FR generators with Mother/daughter or uniboard controller)

TP-5150 - Parts list - RFR II GENERATORS. (Early FR II Generators with DEC II controller.)

TP-5276 - Parts list - FR II GENERATORS. (FR II Generators manufactured after 1/87. DEC 3 Controller and split Activator.

TP-5408 - Parts list - FR II GENERATORS. (FR II Generators with DEC 3 Enhanced controllers, Split Activator, 20-180ROZJ, JD powered.)

TP-5354 - Parts list - FR II GENERATORS. (FR II Generators with DEC 3 Enhanced controller, Split Activator, 200-300ROZD, DD powered.)

TP-5543 - Parts list - FR II (20 - 30KW Ford Powered with DEC 3 Enhanced Controller).

TP-5613 - Parts list - FR II (33 - 45KW Ford Powered with DEC 3 Enhanced Controller).

TP-5614 - Parts list - FR II (50 - 100KW Ford Powered with DEC 3 Enhanced Controller).

TP-5400 - DESIGN & APPLICATION INFORMATION. (Technical and Application Guide Book)

TP-5700 - INSTALLATION GUIDE. (Stationary Duty.)

# Safety Precautions and Instructions

A generator set, like any other electro-mechanical device, can pose potential dangers to life and limb if improperly maintained or imprudently operated. The best way to prevent accidents is to be aware of the potential dangers and to always use good common sense. In the interest of safety, some general precautions relating to the operation of a generator set follow. Keep these in mind.

## DANGER

Danger is used to indicate the presence of a hazard that will cause severe personal injury, death, or substantial property damage if the warning is ignored.

## WARNING

Warning is used to indicate the presence of a hazard that can cause severe personal injury, death, or substantial property damage if the warning is ignored.

## CAUTION

Caution is used to indicate the presence of a hazard that will or can cause minor personal injury or property damage if the warning is ignored.

## NOTE

Note is used to notify people of installation, operation, or maintenance information that is important but not hazard-related.

Safety decals are affixed to the generator set in prominent places to advise the operator or service technician of potentially hazardous situations. The decals are reproduced here to improve operator recognition and thereby increase decal effectiveness. For a further explanation of decal information, reference the accompanying safety precautions. Before operating or servicing the generator set, be sure you understand the message of these decals. Replace decals if missing or damaged.

---

## WARNING

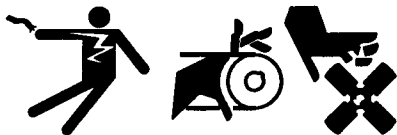

### Accidental starting.

### Can cause severe injury or death.

Disconnect battery cables before working on generator set (negative lead first and reconnect it last).

---

## WARNING



### Sulfuric acid in batteries.

### Can cause severe injury or death.

Use protective goggles and clothes. Battery acid can cause permanent damage to eyes, burn skin, and eat holes in clothing.

---

## WARNING

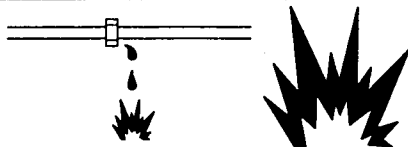

### Explosive fuel vapors.

### Can cause severe injury or death.

Use extreme care when handling, storing, and using fuels.

---

## CAUTION





### Hazardous noise.

### Can cause loss of hearing.

Never operate generator without a muffler or with faulty exhaust system.

# SAFETY PRECAUTIONS

<b>⚠ WARNING</b>

<b>Hot coolant and steam.</b> <b>Can cause severe injury or death.</b>  Before removing pressure cap stop generator, allow to cool and loosen pressure cap to relieve pressure.

<b>⚠ WARNING</b>

<b>Explosion.</b> <b>Can cause severe injury or death. Relays in battery charger cause arcs or sparks.</b>  Locate in a well ventilated area. Keep explosive fumes away.

<b>⚠ WARNING</b>

<b>Hot engine and exhaust system.</b> <b>Can cause severe injury or death.</b>  Do not work on generator set until unit is allowed to cool.

<b>⚠ WARNING</b>

<b>Carbon monoxide.</b> <b>Can cause severe nausea, fainting, or death.</b>  The exhaust system must be leakproof and routinely inspected.

<b>⚠ WARNING</b>

<b>Unbalanced weight.</b> <b>Improper lift can cause severe injury, death, or equipment damage.</b>  Do not use lifting eyes. Use lifting bars thru holes in skid to lift set.

<b>⚠ WARNING</b>

<b>Hazardous voltage.</b> <b>Backfeed to utility system can cause property damage, severe injury, or death.</b>  When generator is used for standby power, use of automatic transfer switch is recommended to prevent inadvertent interconnection of standby and normal sources of supply.

# SAFETY PRECAUTIONS

<b>⚠ WARNING</b>

<b>Rotating parts.</b> <b>Can cause severe injury or death.</b>  Do not operate generator set without all guards, screens, or covers in place.

<b>⚠ WARNING</b>

<b>Fire.</b> <b>Can cause severe injury or death.</b>  Do not smoke or permit flame or spark to occur near fuel or fuel system.

<b>NOTICE</b>
<b>This generator set has been rewired from its nameplate voltage to:</b>  <div style="border: 1px solid black; height: 40px; width: 100%;"></div>
246242

<b>NOTICE</b>
<b>This is a positive terminal only.</b> <b>Do not attach negative lead!</b>

## NOTE

Wipe up all spilled diesel fuel after bleeding system. Wash hands after any contact with fuel oil.

## NOTE

Split lock washers may be supplied with some kits. If split lock washers are supplied with kit, their use is optional.

## NOTE

**HARDWARE DAMAGE!** Engine and generator may make use of both American Standard and metric hardware. Be sure to use the correct size tools to prevent rounding of bolt heads and nuts.

## NOTE

Special attention should be given when checking for proper coolant level. After the coolant has been drained, some time is required before complete refill of the engine water jacket takes place.

## NOTE

**ENGINE DAMAGE!** Failure to bleed air from cooling system may cause overheating and subsequent damage to engine.

## NOTE

Charge only LEAD-ACID or NICKEL-CADMIUM batteries with battery charger.

## NOTE

**When replacing hardware, do not substitute with inferior grade hardware.** Screws and nuts are available in different hardness ratings. American Standard hardware uses a series of markings and metric hardware uses a numeric system to indicate hardness. Check markings on bolt head and nuts for proper identification.

## FAST RESPONSE GENERATORS

Kohler FR1 FAST RESPONSE Generators were introduced in 1976 and featured a new concept of field excitation control. Although component design, location and appearance has changed over the years, the basic concept remains the same on current FR11 FAST RESPONSE Generator sets.

The KOHLER 'DECISION MAKER' Controller has also seen many design changes since its introduction on the FR1 Generators. The original solid state 'Mother/Daughter' board has since evolved into a Micro Processor based controller. KOHLER will continue to offer Generator and Control designs using the latest technologies.

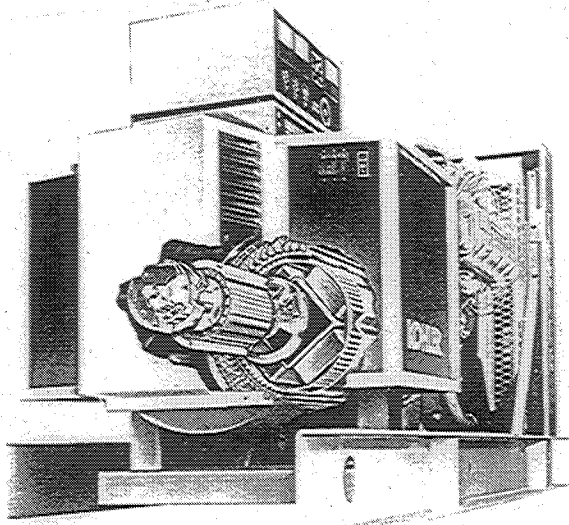

FR1

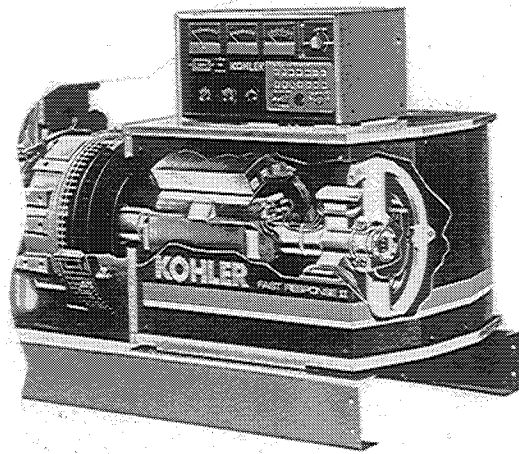

FR11

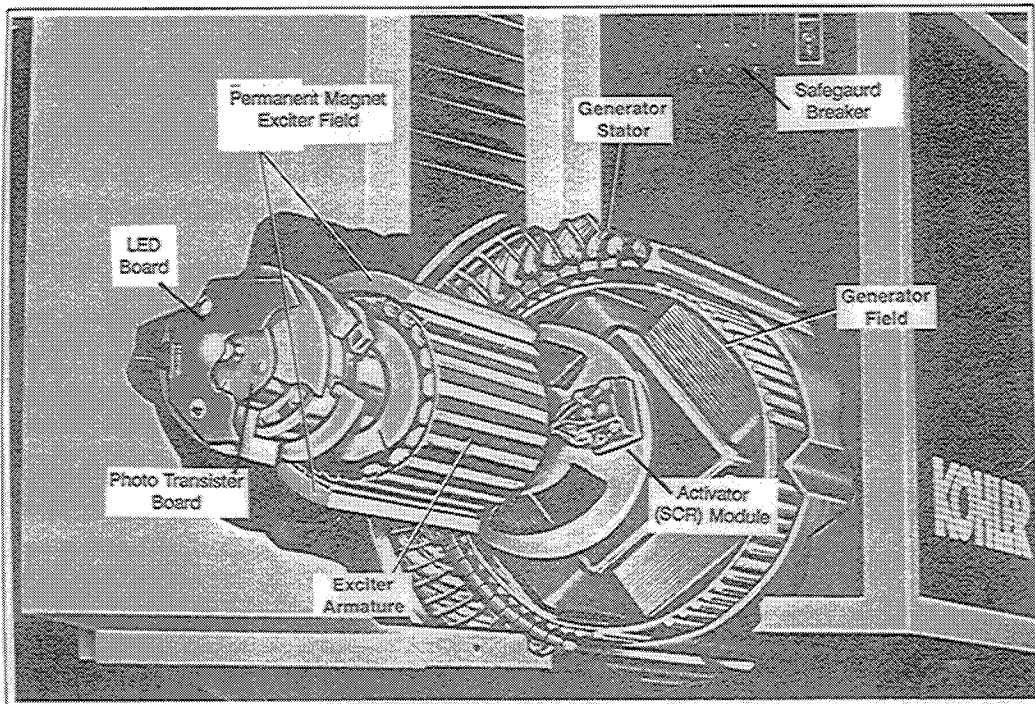

# FAST RESPONSE

The term **FAST RESPONSE** refers to the generators ability in responding to load changes. These generators typically recover from voltage transients in .05 seconds compared to a half second or even two full seconds for conventional brushless models.

Conventional brushless generator response time is inherently slow due to a double lag - first, the exciter generator response when the exciter field is energized, then the typical main generator response time.

The **FAST RESPONSE** Generator eliminates the exciter lag time by replacing the wound exciter field with permanent magnets. The exciter generator is therefore capable of delivering full excitation directly to the Main generator field in the time required to trigger the SCR module.

Excitation power on conventional generators is dependent on the main generator output. If a circuit connected to the generator is exposed to a short, exciter voltage as well as line voltage drops. This reduction of voltage does not provide sufficient current to trip the breaker connected in the fault circuit therefore affecting all remaining circuits connected to the system. As the **FAST RESPONSE** excitor generator features a permanent magnet field it is not dependent on the main generator output and will support the main generator field during a short circuit. The ability to sustain at least 300% of rated current allows the fault circuit breaker to trip clearing the fault from the system without disruption to the remaining load circuits.

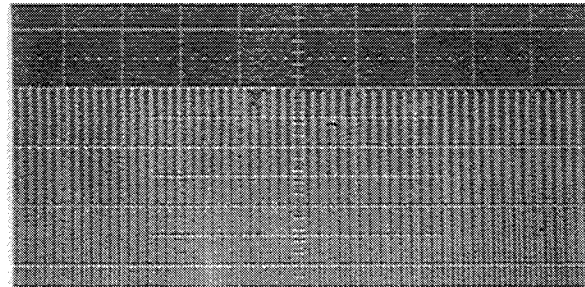
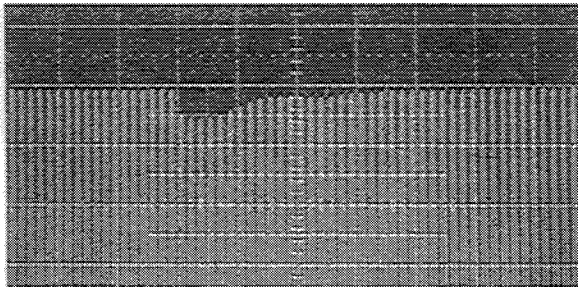

**Response to load change.** The oscilloscope record at left shows the prolonged voltage drop of a 50 KW conventional brushless generator operating at no load upon one step application of full load at 0.8 power factor. The record at right shows the recovery time of a 50 KW Fast Response II generator operating under the same conditions. The fast recovery (within 2 cycles) aids motor starting capability and greatly reduces light dimming due to load changes.

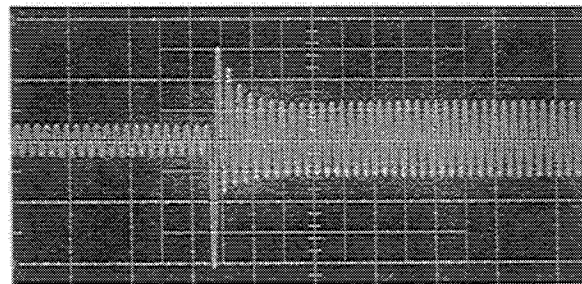
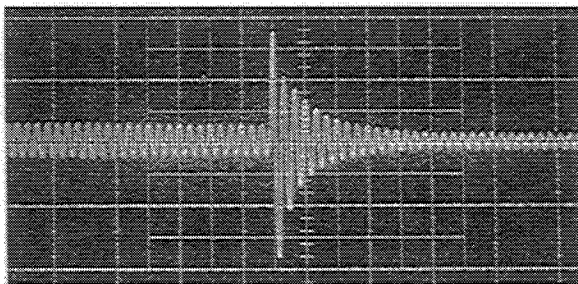

**Sustained short circuit performance.** A 3-phase symmetrical short circuit of a generator set operating at full load — a worst case situation — is shown on both oscilloscope screens. The trace at left follows a conventional brushless generator operating at rated current with a surge current tapering to less than the rated level upon application of the short. The trace on the screen at right shows a Fast Response II generator of the same rating operating under identical conditions, with the current rising above its rated level, enabling it to trip branch circuit breakers.



# ALTERNATOR DESIGNS

Mechanical alternators or generators that produce an A.C. output are either of the rotating armature or the rotating field design and require 3 basic things.

1. - **Conductors.**
2. - **A magnetic Field.**
3. - **Movement** between the two.

1. The **Conductors** are copper wires wound in slots of laminated steel referred to as the armature and provide the generated output voltage.
2. The **Field** is the invisible magnetic force produced by electro-magnetic pole pieces.
3. **Movement** between the field and conductors is necessary to create current flow in the armature windings and is usually provided by a gas or diesel engine.

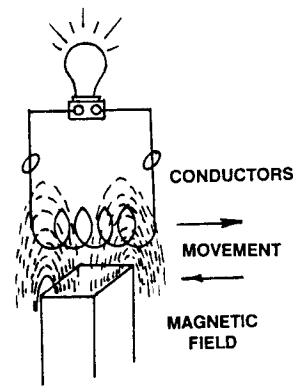

## ROTATING ARMATURE GENERATORS

The AC generated output power from this type generator is produced in the rotating component and slip rings and brushes are required to transfer the current to the customer's stationary load. The field windings are wound on laminated steel pole pieces located in the stationary iron shell. Size of these generators are usually limited to 20 KW due to the brushes. These generators are not reconnectable between single and three phase voltages.

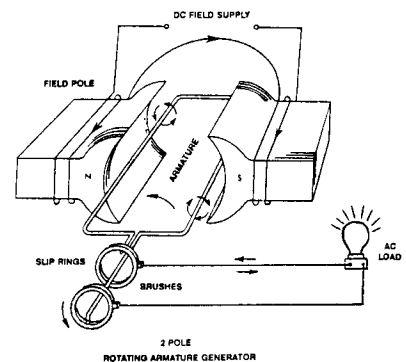

## ROTATING FIELD GENERATORS

Alternators used on most standby generator sets today are of the Rotating field design. The magnetic poles rotate past the armature windings. As the armature windings are stationary, no brushes are required for transfer of AC power to the customer load. The stationary armature also allows for easy reconnection of the windings to permit various three phase or single phase voltages.

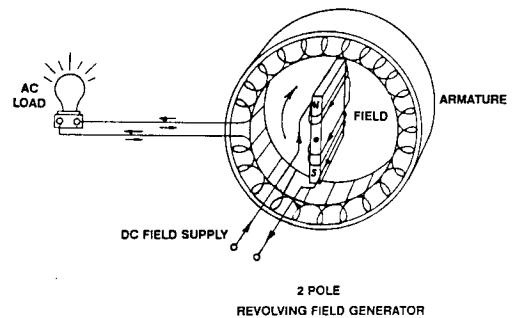

These generators usually utilize a small rotating armature generator to produce the excitation power for the main generator field windings. This power is converted from AC to DC by a diode bridge. The armature rotates on the same shaft as the main field and therefore does not require slip rings and brushes. As the field windings for these exciter generators are stationary, the regulated control circuit can be directly connected, again eliminating the need for brushes and slip rings. A SCR Exciter/Regulator is used to supply a regulated DC supply to the field. Input power to the SCR circuit is from the main armature (stator) output.

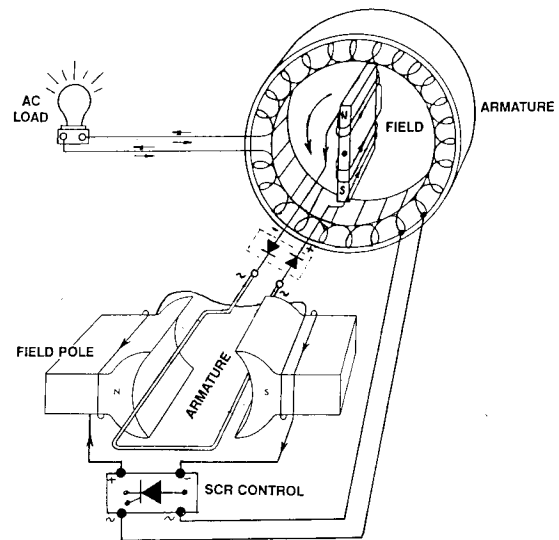

# ALTERNATOR DESIGNS

## FIELD EXCITATION

Generators supplying the Standby/Prime power market are of the salient pole, rotating field type. The main AC Power producing components, namely the stator and the Rotor of these generators have changed very little over the years.

The excitation circuit, the components supplying the main field with the required D.C. power, has however seen many design variations, mainly since the appearance of solid state components such as the SCR.

A brief description of the most common types of excitation systems in use today follows.

### STATIC EXCITED (Exciter Regulators)

This system rectifies AC power from the output of the generator and sends a controlled DC current to the rotating field through brushes/collector rings. This exciter can be of a magnetic amplifier type; however, it is usually an SCR bridge controlled by a solid state voltage regulator circuit. This system is quite fast operating and can be designed to have excellent load response and voltage regulation.

Disadvantages of static excited designs are found in the rotor collector rings and brushes. These components are subject to routine maintenance.

### (POWER BOOST)

On generator sets below 20 KW, Kohler features a patented POWER BOOST exciter regulator. It employs a separate auxiliary stator winding ( independent of the main output) to power the field during fluctuations caused by load-on/load-off situations. This system provides excellent motor starting ability and maintains virtually constant voltage.

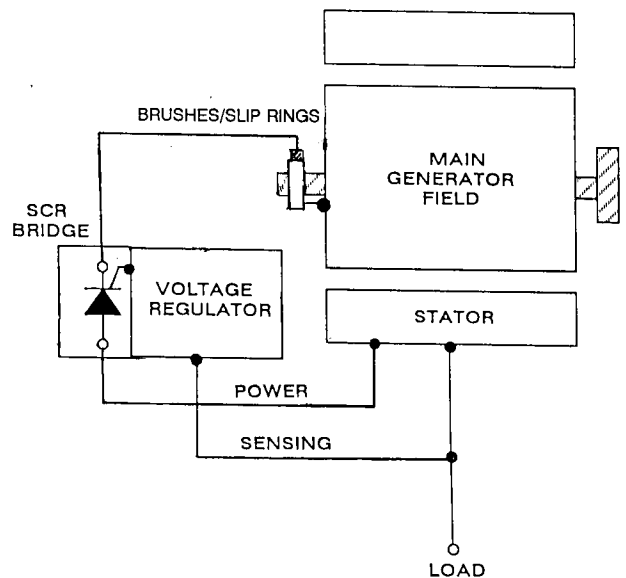
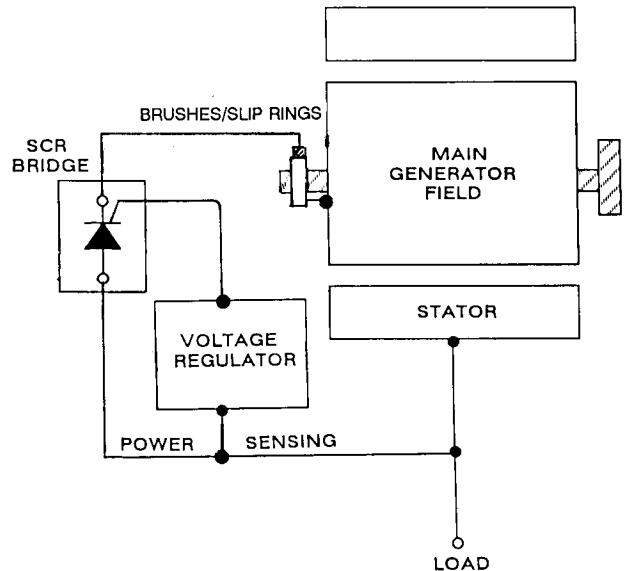

# ALTERNATOR DESIGNS

## WOUND-FIELD BRUSHLESS EXCITED

This system uses a wound exciter armature which rotates on the same shaft as the main field. A voltage regulator supplies a regulated DC to the field of the exciter generator by means of rectifying a small amount of the AC output from the main generator.

The system uses a solid state voltage regulator and is immune from the large power spikes inherent in the static excited-type machine. It is also completely brushless. It is self-protecting on short circuit or extreme overload, as the generator voltage collapses, but leaves loads without power.

The chief disadvantage of this type system is that it has the inherent time constant of the exciter field, which makes it considerably slower in recovery time compared to the static excited-type.

While this type machine is self-protecting, it will not selectively trip branch circuit breakers because of its collapsing voltage characteristic.

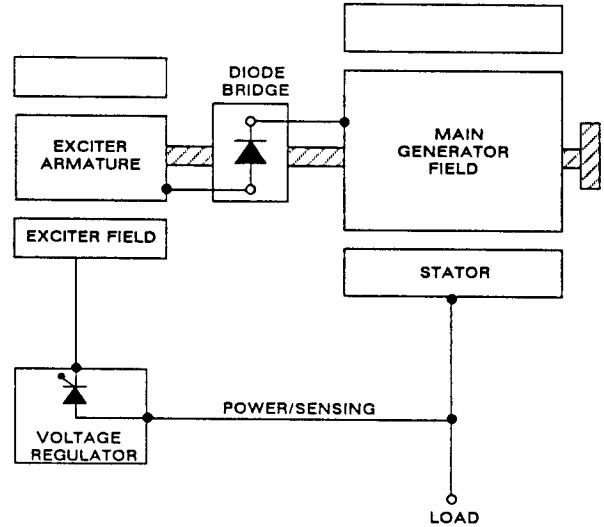

## PILOT PM BRUSHLESS EXCITED

A brushless wound exciter generator with a rotating permanent magnet field Pilot generator is used on Generators larger than the Kohler FR generator set series.

Excitation for the exciter generator field is supplied from the stator output of the Pilot Generator.

The exciter armature output is rectified and supplies the Main generator field with excitation power.

Since the only connection to the load windings are for regulator sensing the regulator is immune to effects of SCR load induced harmonics.

The permanent magnet pilot generator allows the generator to support short circuit currents for circuit breaker tripping.

## WOUND-FIELD BRUSHLESS EXCITED

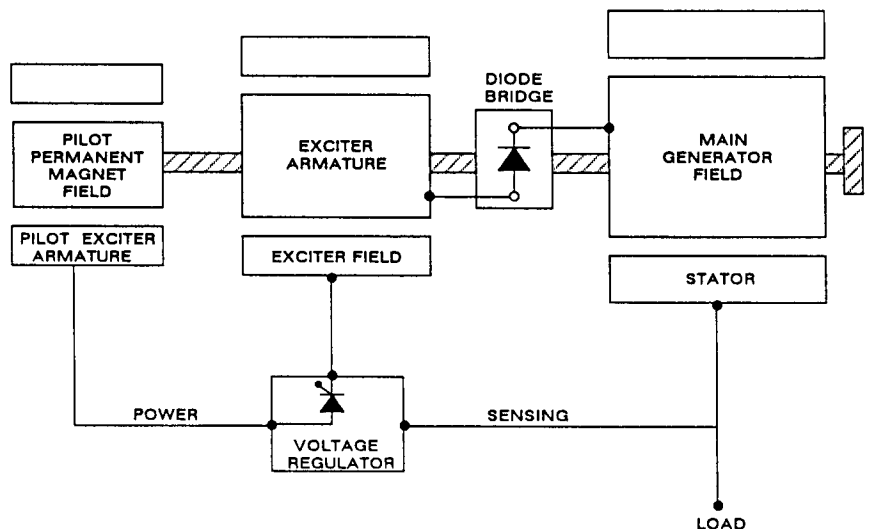

## PM PILOT BRUSHLESS EXCITED

# ALTERNATOR DESIGNS

## KOHLER FAST RESPONSE

The Fast Response excitation system uses a permanent magnet exciter with a rotating SCR (thyristor)-type bridge referred to as the FR MODULE. The module controls the DC current fed to the generator field.

This design uses a voltage regulator, which signals the rotating SCR bridge through an optical coupling.

The voltage regulator senses the output voltage of the generator and turns a stationary LED (light emitting diode) on or off, depending upon the level of the output voltage. Voltage supply to the regulator is from the generator set battery.

The LED is mounted on the end of the generator shaft opposite a photo transistor, which rotates on the shaft. The photo transistor picks up the signal from the LED and tells the SCR rotating bridge to turn on or off depending upon the need, as dictated by the voltage regulator.

This type generator has a voltage recovery time several times faster than the conventional wound field brushless generator, because it does not have the inductance of the exciter field to contend with. It combines the fast response characteristics of the static exciter generator with the short circuit current sustaining capability and relative immunity to load induced harmonics of the pilot exciter design.

The optional Safeguard Breaker protects the generator in the event of extended non-protected overloads by disabling the photo coupling signal to the SCR module.

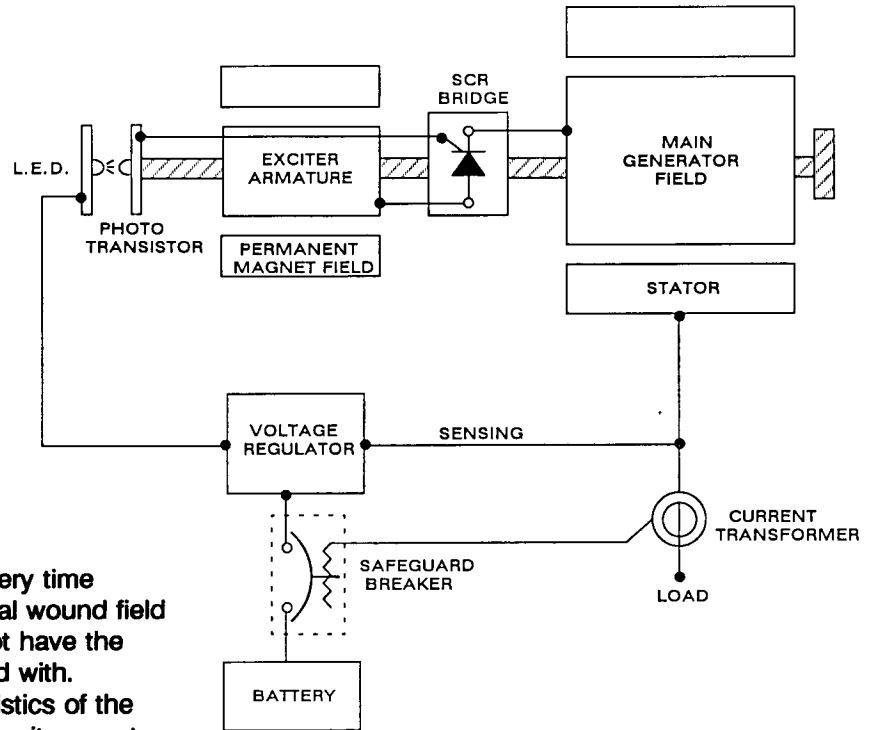

# ALTERNATOR ASSEMBLY

## KOHLER FR1 ALTERNATOR ASSEMBLY

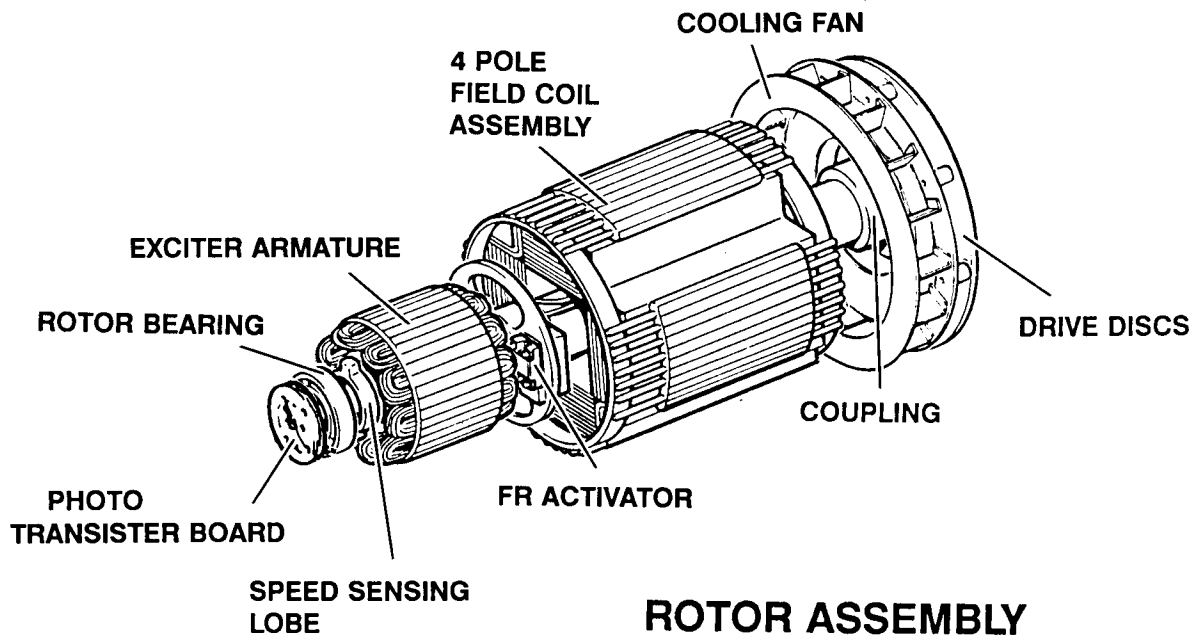
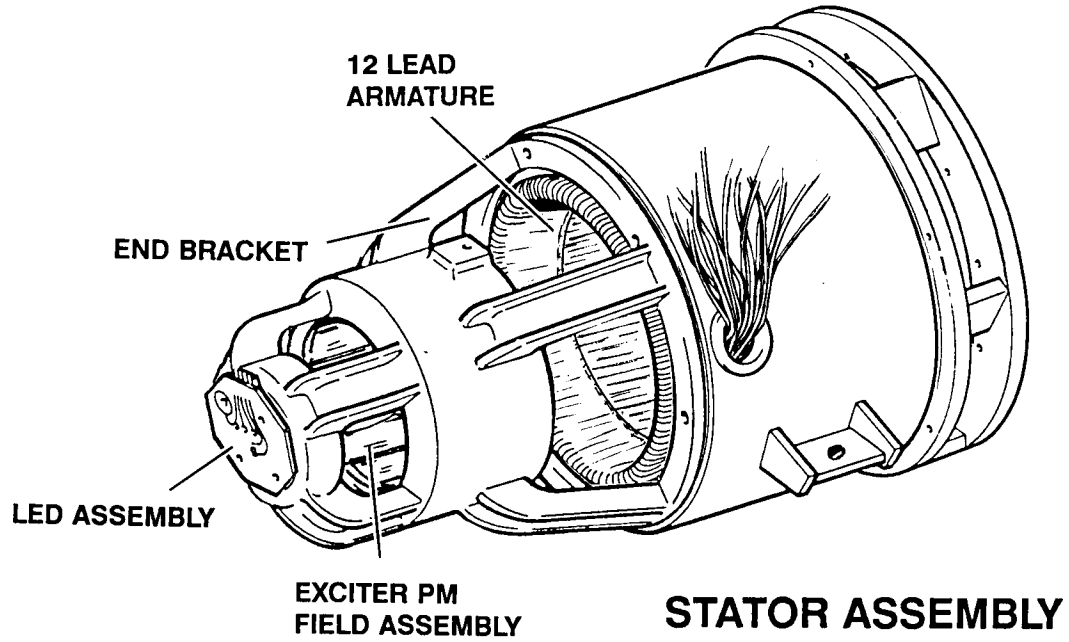

**KOHLER FRII  
ALTERNATOR ASSEMBLY**

**ALTERNATOR ASSEMBLY**

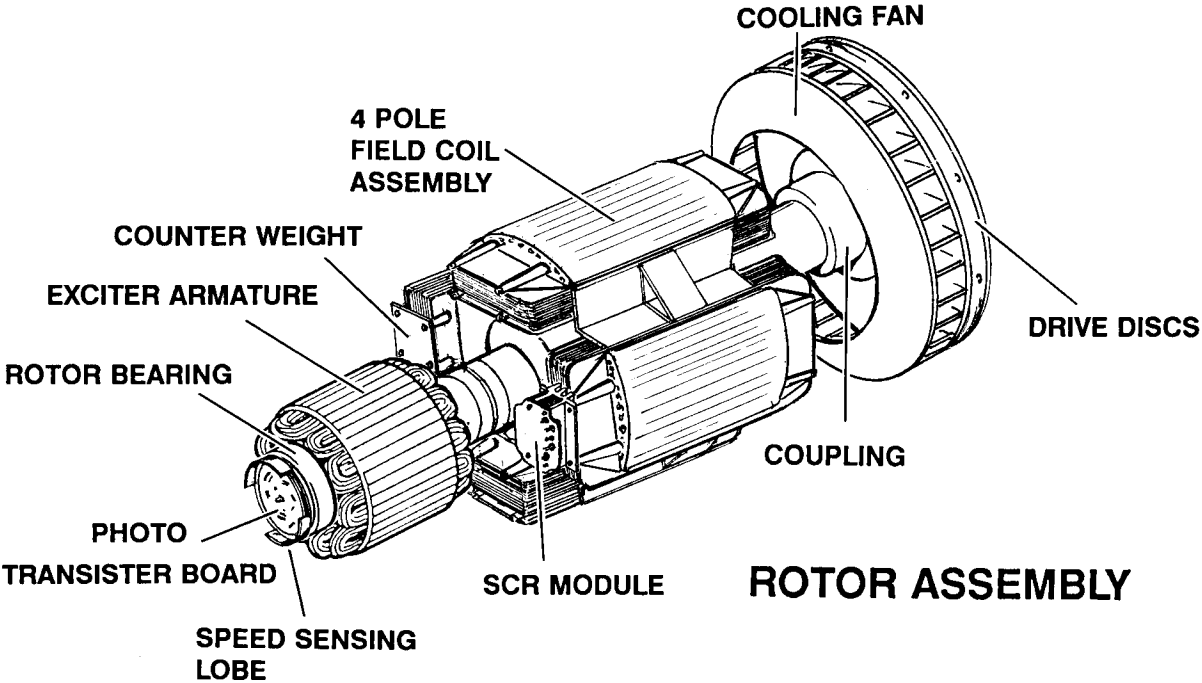
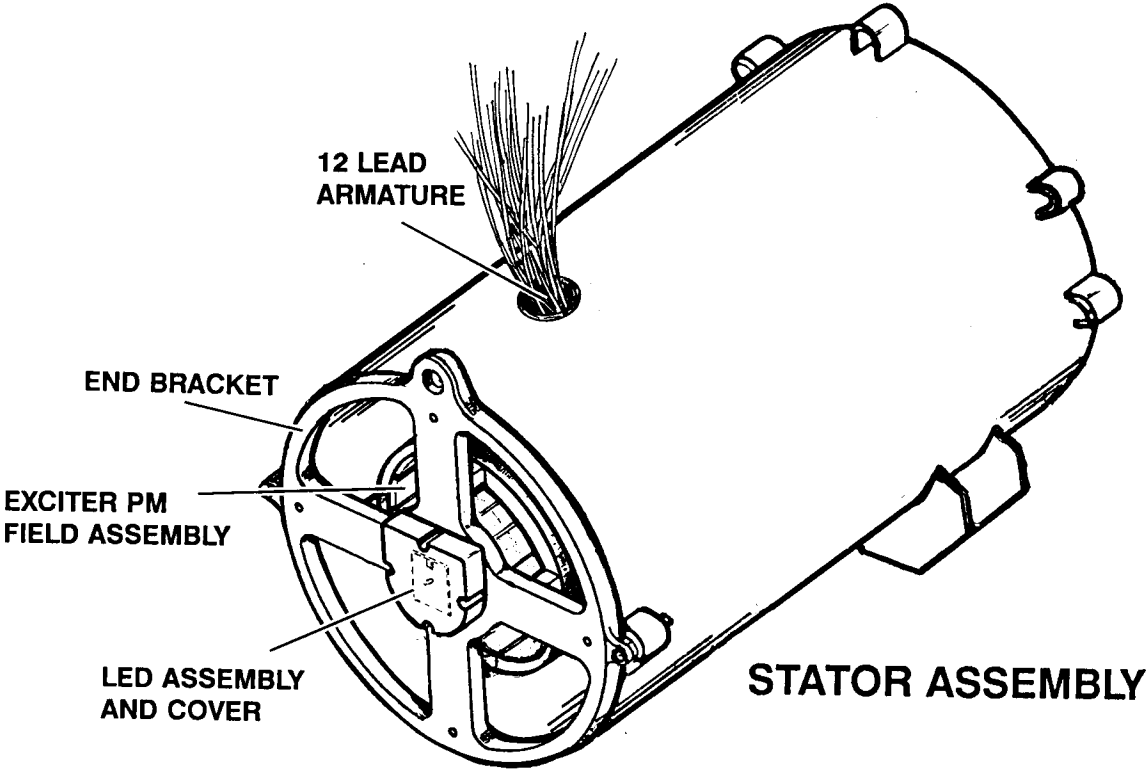

# ALTERNATOR ASSEMBLY

## KOHLER FRII ALTERNATOR ASSEMBLY

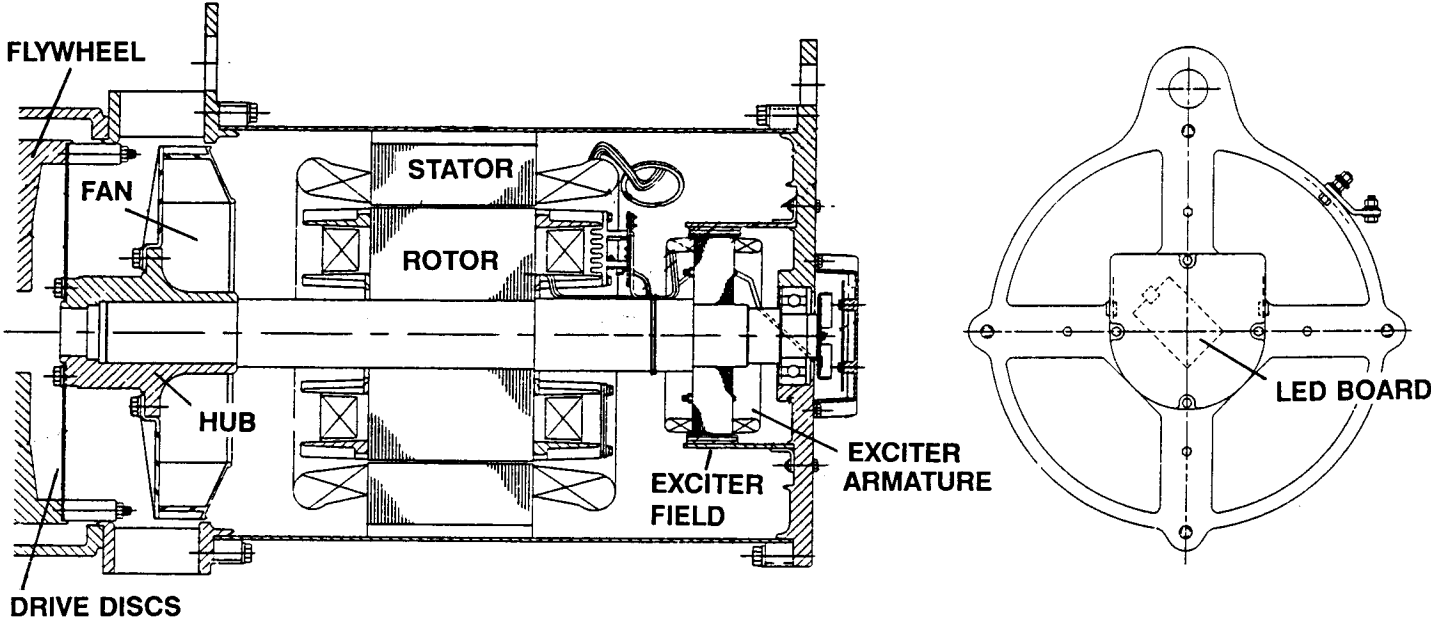

TYPICAL ALTERNATOR ASSEMBLY / DRIVE DISCS

END BRACKET  
(TYPICAL)

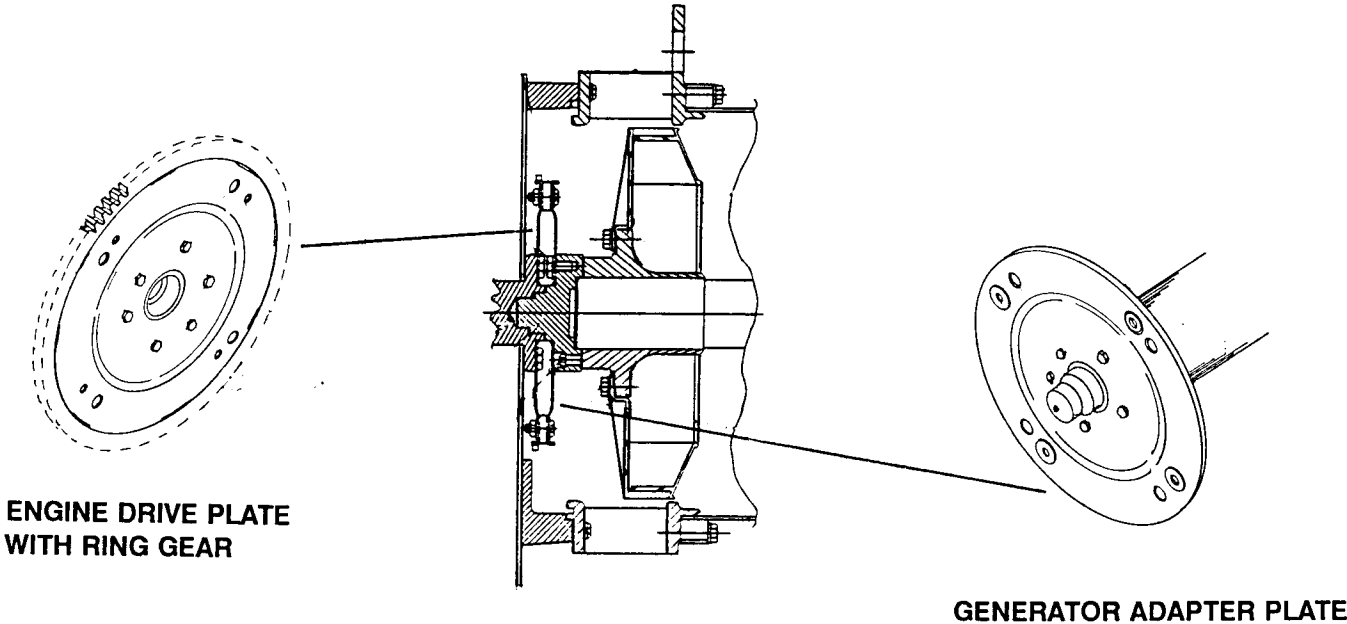

FORD LSG-875  
WITH DRIVE PLATES

# ALTERNATOR ASSEMBLY

## STATOR

The generators installed on Kohler Generator sets have a marketing size code which pertains to the stator lamination stack length, to the nearest inch and the air gap bore diameter in inches.

A Generator model 4S9 is a 4 pole generator with a 12" diameter bore and a lamination length of approx. 9".

This Generator would be supplied on most 100KW models. (Illustration 4S)

If a single phase application is specified an oversize generator (4S13) would be supplied. Also if improved motor starting is required the oversize generator could be specified.

The Marketing code appears on Specification Sheets, Price Lists and the Motor Starting Guide.

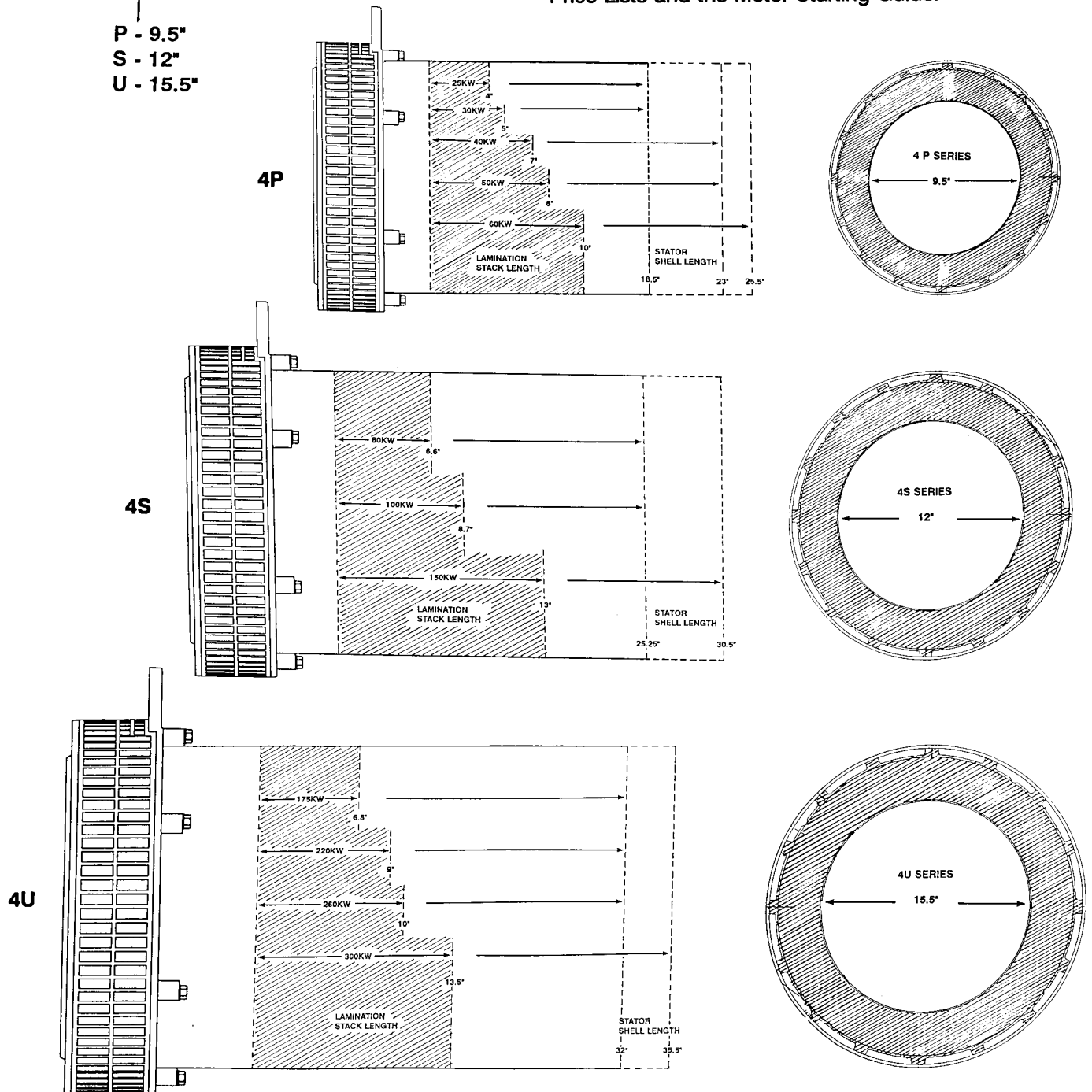
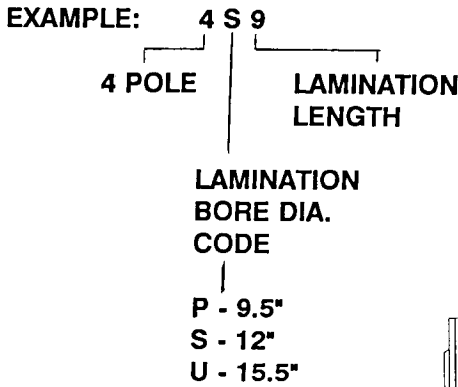



# ALTERNATOR ASSEMBLY

## STATOR ASSEMBLY

Kohler FR generators are of the BROAD RANGE, 12 lead type. The winding is basically a three-phase winding, with each phase wound in two sections.

The generator is able to function properly over the range of 110 to 139 volts per section.

These stators can be reconnected to various 50/60 Hertz voltage configurations including: three-phase Wye, three-phase Delta, and single-phase.

When the stator windings are connected in a 3 phase Wye or Star connection the line voltage ( L1-L2-L3 ) is equal to the vector summation of the phase to neutral voltage. (L1-L0, L2-L0, L3-L0) or 1.73 times the phase to neutral voltage.

$$120 \times 1.73 = 208 \quad 277 \times 1.73 = 480 \quad 139 \times 1.73 = 240$$

The phase coils can be connected in either a series (high) or parallel (low) configuration. Voltages most often encountered in the high Wye are; 220/380, 240/416 or 277/480. Common voltages for the low Wye connection are 110/190, 120/208 or 139/240.

The most common voltage for the Delta connection is 120/240 or 110/220. Half the phase voltage is available between the series connected coils and the line.(L1-L0)

The 12 lead generator can be connected to supply single phase power. This configuration is referred to as a "dog leg". Both 120 and 240 volt single phase circuits are available with this connection.

When operating at single phase, capacity must be derated due to the heating effects inherent with this connection.

The generators are not reconnectable to 600 volts. Six lead wye connected stators are available for these three phase systems. Voltage from line to neutral is 347 volts. Taps are provided in each phase to provide 120 and 240 volts for metering and regulator connections.

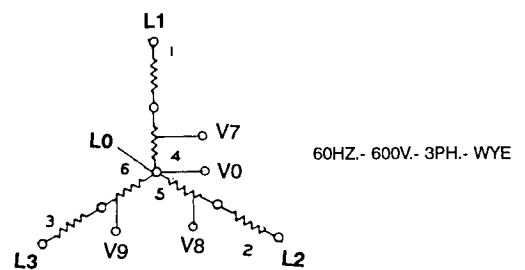
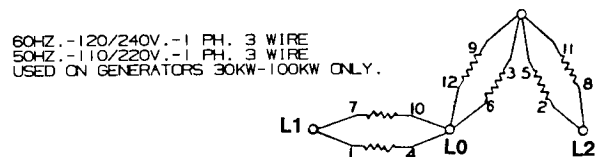
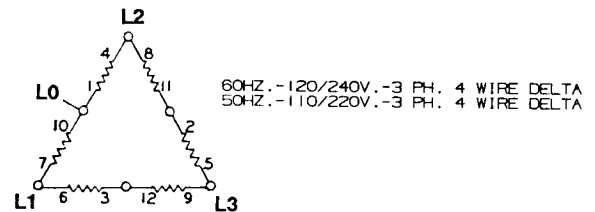
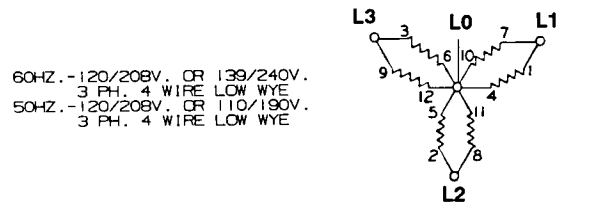
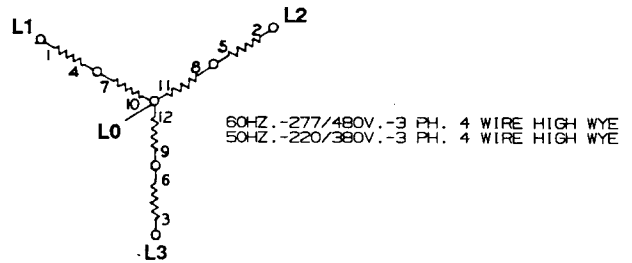

# ALTERNATOR ASSEMBLY

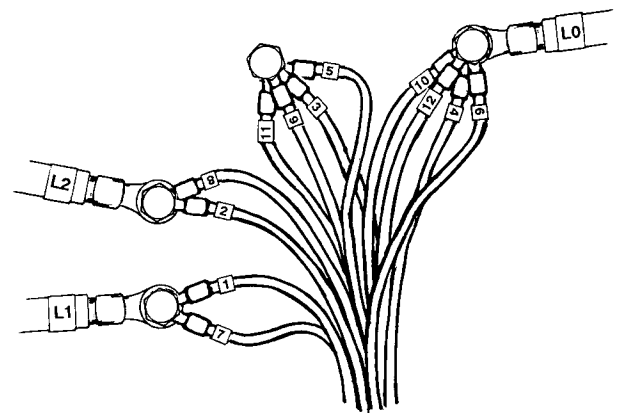
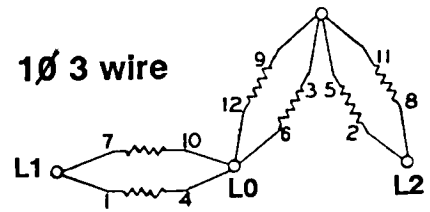
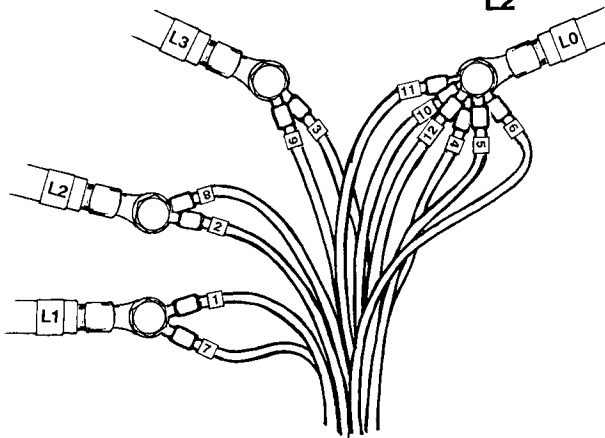
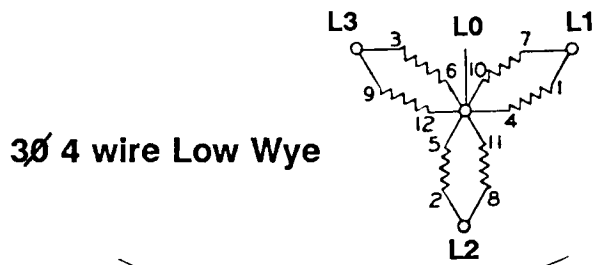
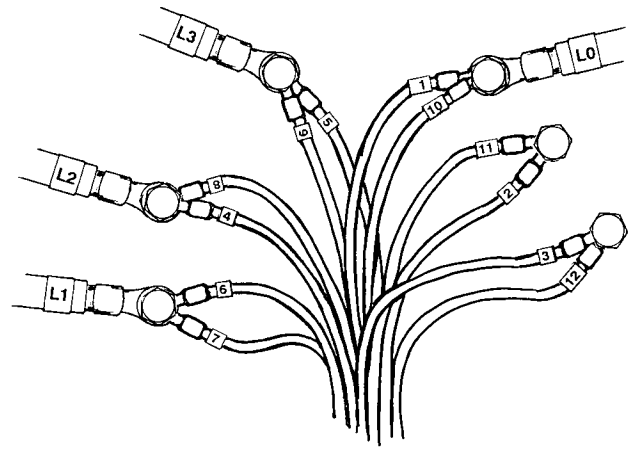
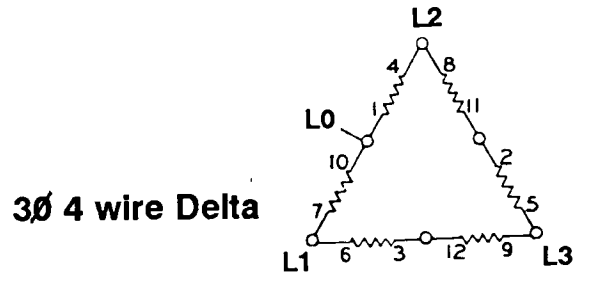
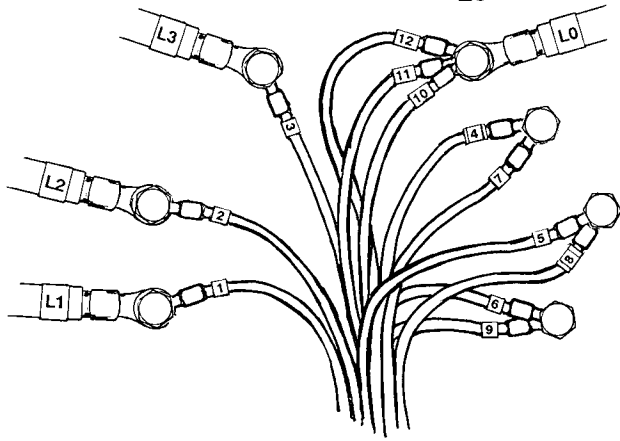
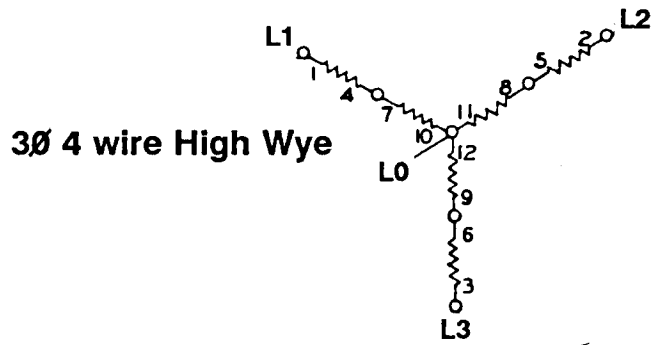

# LOAD UNBALANCE

Generators which are used in a system having a combination of single-phase and three-phase loads are susceptible to load unbalance.

Three-phase loads are self-balancing; however, single-phase loads must be carefully planned and distributed between the phases to obtain balanced voltages and prevent overloading one or two phases.

This is a fairly simple thing to do for Wye connected generators; however, when the three-phase 120/240 volt Delta system is used, a compromise must be made.

In general, loads should be arranged such that the current rating of the generator is not exceeded on any phase.

When calculating three phase systems it is often assumed that the loads to be carried will be evenly balanced. This however is seldom true due to the single phase loads on the system.

The most glaring example is the 120/240 volt three-phase Delta system used for combinations of 120 and 240 volt single-phase loads and 240 volt three phase loads.

It is relatively simple for the system designer connecting his load to a utility to select three single-phase transformers, one of which is made large enough to handle the single-phase load.

The generator set supplier however has a problem in that the three-phase windings of a generator are all equal in size and he has very little control over the load.

All the single-phase loading is connected across one of the phases causing an imbalance. Excessive unbalance could damage the generator as well as three-phase motors connected to the load.

Basic points to remember with three-phase Delta connections are:

- Balance the 120 volt loads.
- Try to keep the single-phase loads to less than 50%
- Keep the line current at any of the three terminals, particularly terminals L1 and L3, within the current rating of the generator.
- Do not load connected motors beyond 80% of their full load rating.

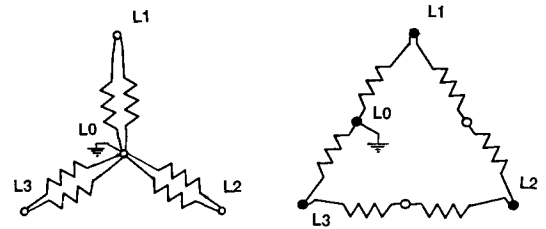

120/208 VOLT 3Ø WYE

120/240 VOLT 3Ø DELTA

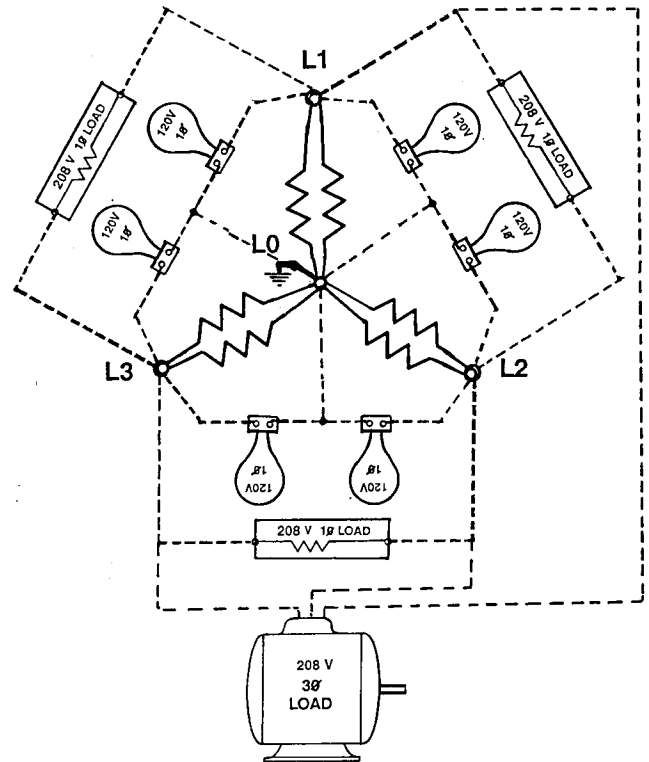

120/208 VOLT 3Ø WYE

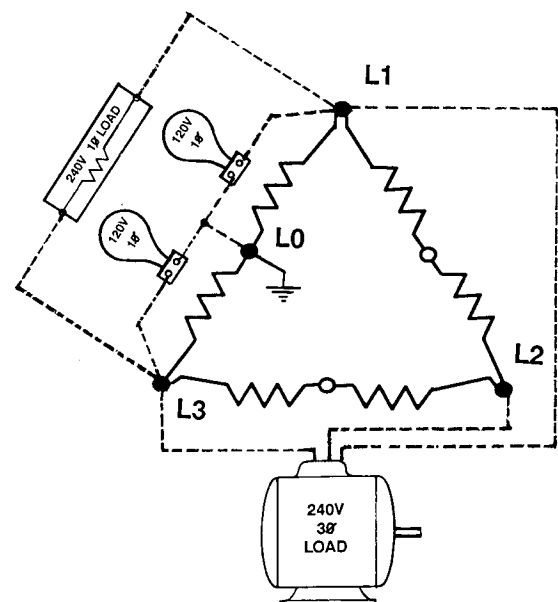

120/240 VOLT 3Ø DELTA

# ALTERNATOR ASSEMBLY

## STATOR ASSEMBLY

The stators are vacuum impregnated with epoxy varnish - Fungus resistant per Mil-I-24092. They will sustain short circuit current at 300% of rated current up to 10 seconds.

Due to the amount of heat produced, most generators furnished today use Class F or H insulation in their construction.

In an ambient of 104°F (40°C), Class F insulation allows a temperature rise of 266°F (130°C) for standby and 221°F (105°C) continuous.

Class H insulation allows a temperature rise of 150°C standby and 125°C for continuous.

Kohler generators are manufactured with Class H insulation but are rated according to the temperature rise limits of Class F Insulation.

The Temperature Rise of the windings is measured by the resistance method. The resistance of the windings at the cold temperature is compared to the resistance when the generator has reached stabilized temperature.

If these generators were operated at maximum ambient temperature and at rated load continuously, the projected life for the continuous rating is 20,000 hours.

It is obvious that generator winding standards are very conservative. In fact, generators rarely fail when operated under normal rated load.

Generator winding failures result from environmental conditions, a weakness in the winding, continuous overload or load unbalance.

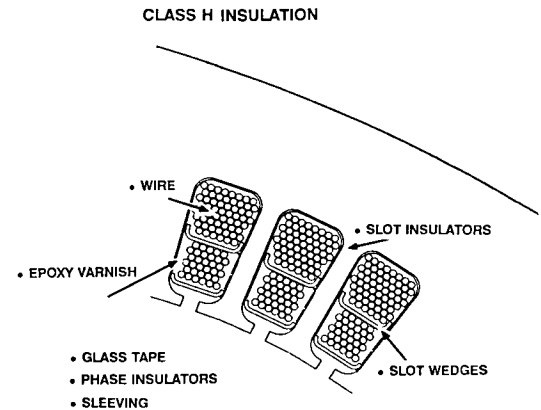

$$\text{TEMPERATURE RISE} = \left[ \frac{R_f}{R_o} \times (T_o + 234.5) \right] - (T_f + 234.5)$$

- R = Resistance (ohms)
- T = Temperature (degrees C)
- o = original (cold)
- f = final (hot)

# ALTERNATOR ASSEMBLY

## STATOR

The purpose for the insulation is to prevent shorting between the windings, lamination slots and any conductive material used in the generators construction.

If this insulation deteriorates or breaks down a current path can be created between the copper windings and the frame structure.

Dirt, grease, chemical fumes, heat, ageing and moisture are some of the contributors to insulation break down.

As part of many scheduled maintenance programs, insulation deterioration tests between the windings and ground are taken for comparison analysis over the life of the generator.

These resistance values are very high. (millions of ohms) A megger is the common instrument used for taking this measurement.

Meggers apply a voltage between the insulated conductor and the material they are insulated from, usually ground. They determine the resistance from the current flow in or over the insulation.

\* Hi-Pots\* producing high potentials (1000v +) should not be used and can add to the deterioration of the insulation.

Prior to operating the megger read and follow the instructions provided with the instrument. Disconnect all loads especially electronic devices, regulator, diodes, circuit boards etc. from the generator.

Maintain continuity between all coils per the particular voltage connection the stator is connected for. (wye, delta) Isolate the neutral leads from ground and connect the megger between the group of neutral leads and ground. Record the megohm readings.

If the insulation resistance is below 1.5 megohms the windings must be serviced. This may require a major repair or merely removal of moisture by a "drying out" process where a current is supplied through the windings for a period of time.

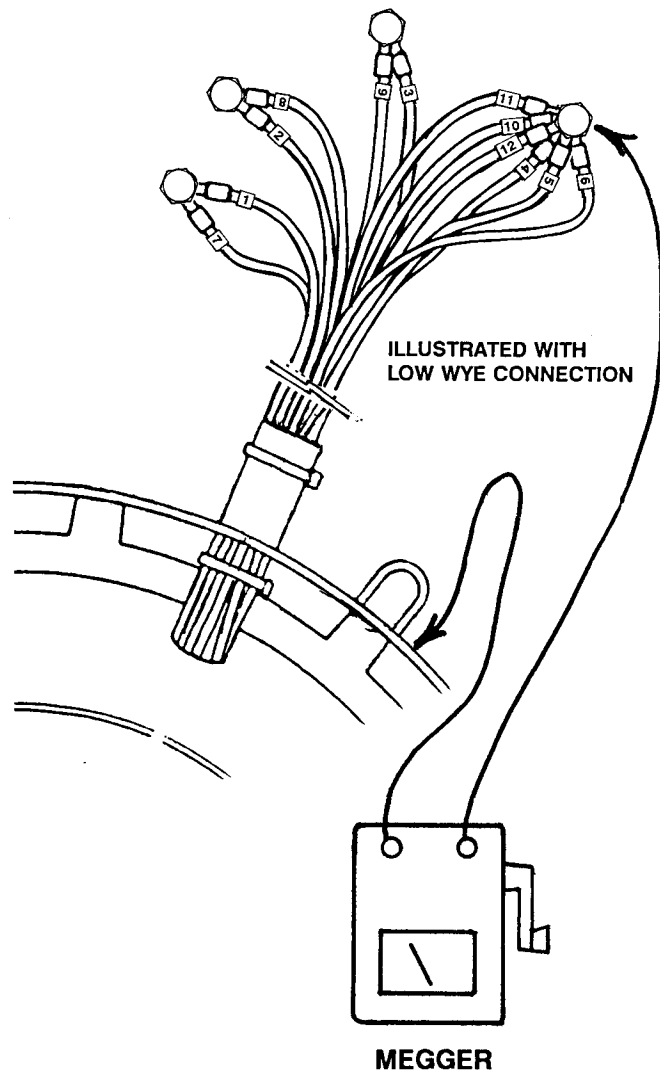

# ALTERNATOR ASSEMBLY

## STATOR COILS

Prior to making any stator checks it is important that the generator set battery be removed to prevent accidental start-up.

Customer load must be completely disconnected from the stator leads.

The resistance value of the stator windings is very low. Use of a VOM is not recommended other than for an indication of continuity. Some may lead the novice technician to assume the windings are shorted.

An instrument such as a Kelvin double bridge capable of indicating accurate readings in the milliohm range must be used if a true resistance value is required.

The "V" low power leads, (V0,V7,V8,V9) are internally connected to the main stator coils, therefore their terminal ends must be removed from the terminal strip to obtain accurate measurements. These leads provide sensing power for the metering and regulator.

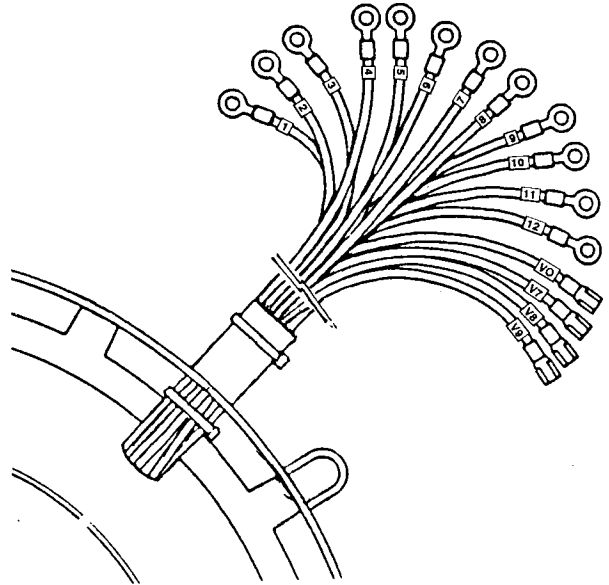

**12 LEAD STATOR**

## STATOR COIL RESISTANCE

### FR ALTERNATORS

<u>CODE</u>	<u>KW</u>	<u>OHMS *</u>
4P4	25	.112
4P5	30	.079
4P7	40	.057
4P8	50	.039
4P10	60	.028
4S7	80	.033
4S9	100	.020
4S13	150	.010
4U7	180	.012
4U9	240	.008
4U10	250	.006
4U10	275	.006
4U13	300	.005

\* All values in ohms @ 25° C  
Tolerance is +/- 10%

### 6 STATOR COILS

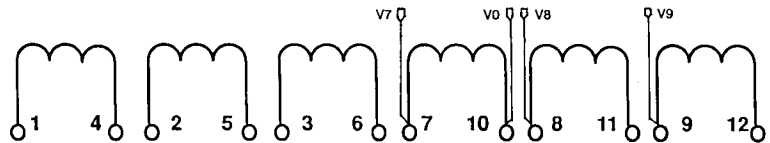

Ohms value is the same for each of the 6 individual coils, 1 - 4, 2 - 5 etc.

# ALTERNATOR ASSEMBLY

## STATOR COILS

It is not necessary to separate the coils in a Wye connected generator to measure coil resistances.

The total value of the coils connected in series is the sum of the individual coils.

Resistance readings can be taken; between Line to Line, Line to Neutral, or between the 6 individual coil groups of a High Wye connected generator.

In a Low Wye connection the coils in the line to neutral are connected in parallel. The total resistance of the parallel coils is half the value of one of the individual coils.

In a Delta connection it is necessary to "open" one of the series coil connections prior to measurement to eliminate the series/parallel circuit.

**NOTE:** A considerably higher resistance value than specified may be indicated when measured between Line to Line if a loose, corroded or insufficiently torqued bolted terminal connection exists

### EXAMPLE:

4P4 - 25KW STATOR = .112 OHMS/COIL.

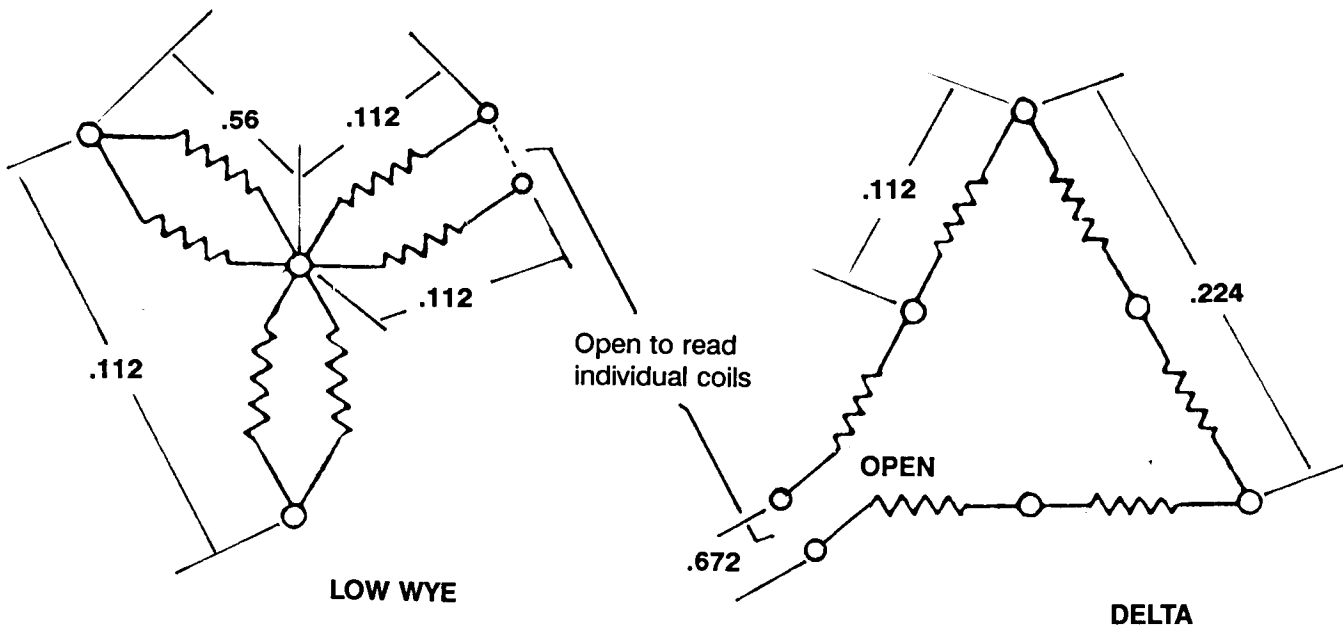
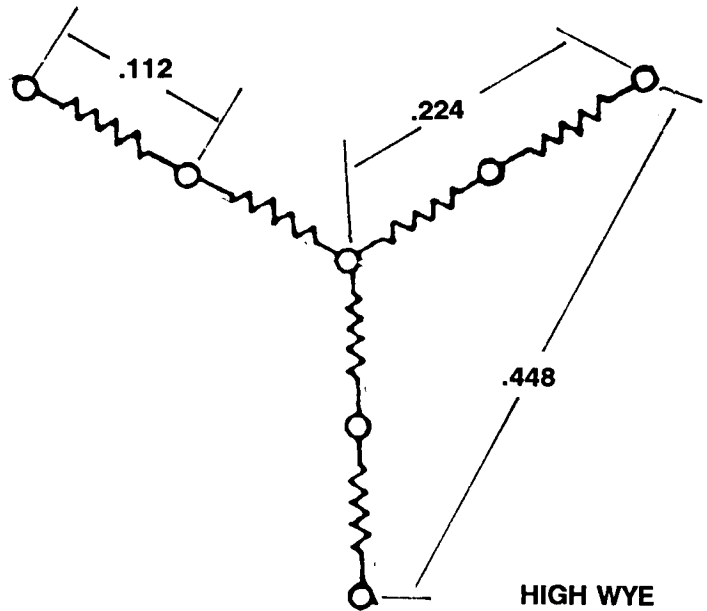

# ALTERNATOR ASSEMBLY

## STATOR

### PM EXCITER FIELD

The exciter generator is of the permanent magnet rotating armature type. The frame assembly is bolted to the main stator end bracket and is recessed in the stator frame.

It contains rows of 8 ceramic magnets cemented to the interior circumference.

Each magnet contains both a north and a south pole totaling 16 magnetic poles. The exciter therefore produces a 240 cycle AC output @ 1800 RPM.

The use of a PM exciter field allows the exciter armature to be at maximum excitation voltage whenever the engine is rotating at rated speed.

Three sizes of exciter generators are used for the FR Generator series. 25-30KW, 40-150KW, 180-300KW.

Magnets may have cracks, provided all pieces are securely fastened to the frame. All loose pieces must be removed. Total volume of missing pieces of any one magnet may not exceed 5% of the magnets original volume.

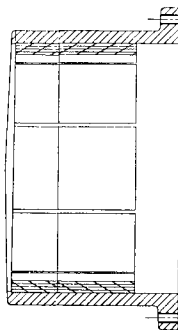
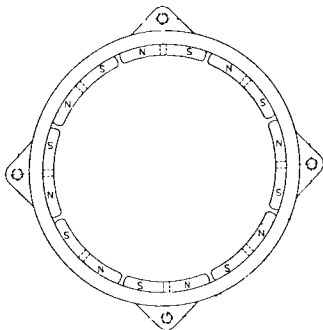
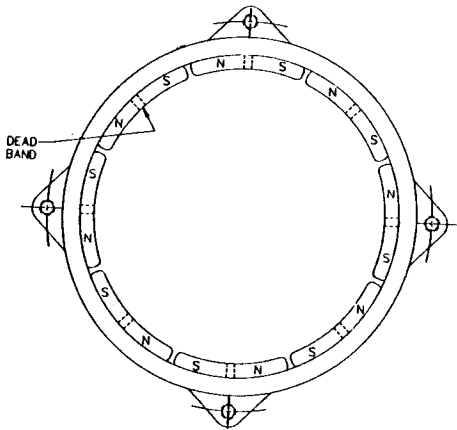
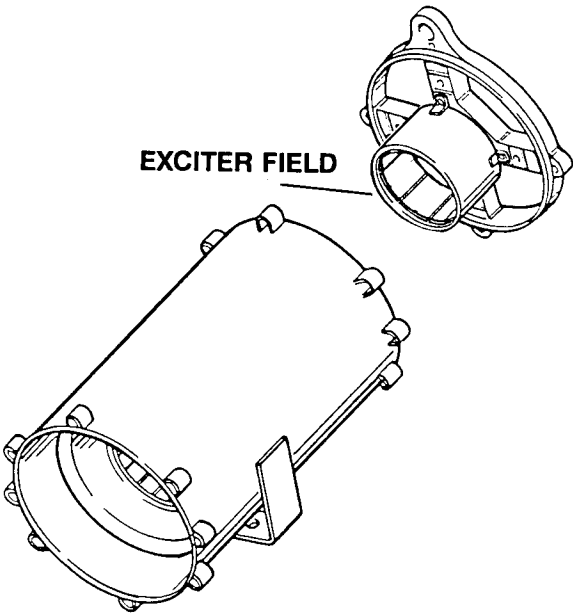

25-30KW

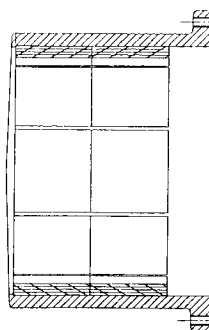

40-150KW

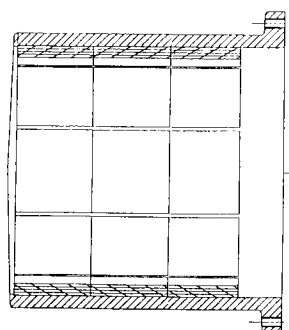

180-300KW



# ALTERNATOR ASSEMBLY

## ROTOR

Three sizes of rotor assemblies match the 4P, 4S and 4U code FR stators.

The Rotating 4 pole, main field assembly and exciter armature are pressed onto a common shaft along with a hub assembly which is bolted to drive discs for direct connection to the engine flywheel.

The exciter armature end of the shaft is supported in the end bracket with a bearing.

The laminations of the main field pole assembly are assembled with the poles skewed in relation to the stator slots. This improves the generators output wave shape by reducing harmonics resulting from the flux produced by the armature winding current.

Amortisseur windings or damper bars are utilized in the rotor laminations. These windings consist of aluminum rods inserted in holes in the laminated pole pieces. The windings or rods are short circuited by welding them to the pole end plate.

The purpose of these windings is to reduce the heating of the rotor by reducing the eddy currents. These windings also reduce the tendency of the alternator to hunt with load changes or when paralleling with other alternators.

The field coils are alternately wound on the pole pieces or connected during assembly to produce alternate magnetic pole polarity. (N - S - N - S)

Wedges help hold the windings from movement due to centrifugal forces. The rotors are vacuum impregnated with epoxy varnish, baked and dynamically balanced.

The series connected field coils connect to the F+ and F- output terminals of the SCR module. Main field resistance can be measured at these leads. Nominal rotor resistances are 1 to 3 ohms.

To insure proper resistance readings with an ohmmeter and to prevent damage to the SCR's when checking insulation condition with a megger, first remove the field leads from the module terminals.

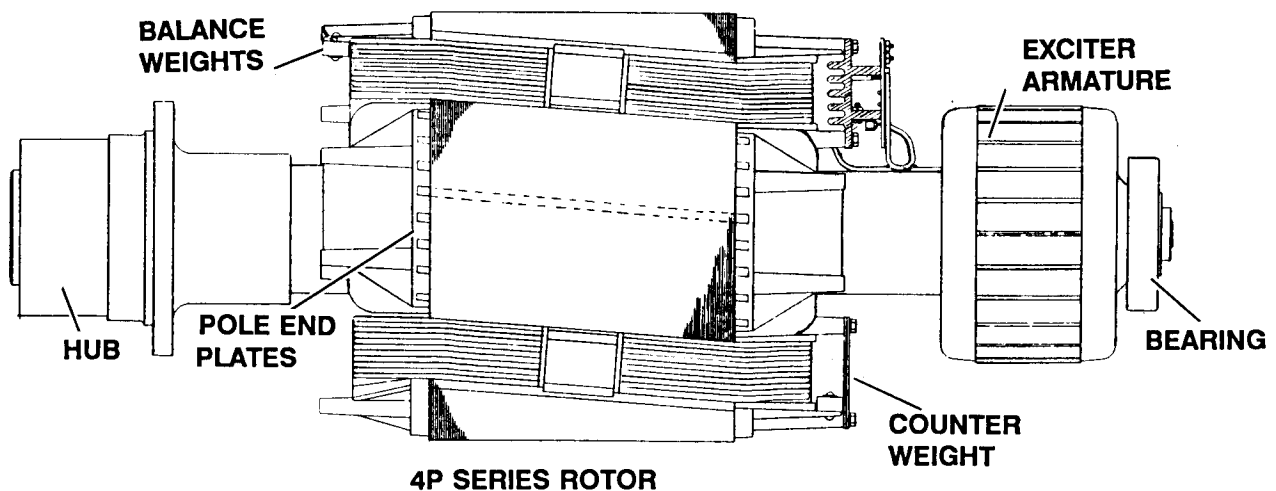
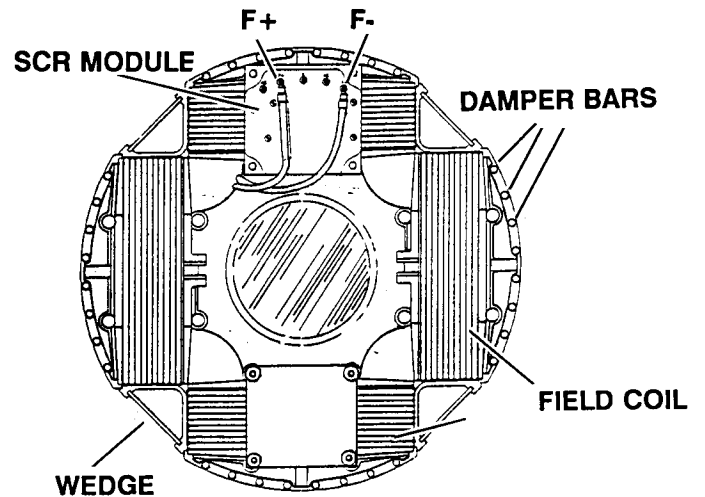

# ALTERNATOR ASSEMBLY

## ROTOR

### EXCITER ARMATURE

The exciter armatures are pressed onto the main shaft and provide the excitation voltage for the main generator field.

As these exciter armatures use permanent magnets for their field supply, they perform as a saturated field generator and supply continuous maximum output whenever operating at rated RPM.

These rotating armature generators provide output power of 1500 to 3500 watts with a potential of 120 - 150 volts AC.

The armature leads connect to the AC input terminals on the SCR module.

Resistance values of the armature windings are between .2 to .7 ohms.

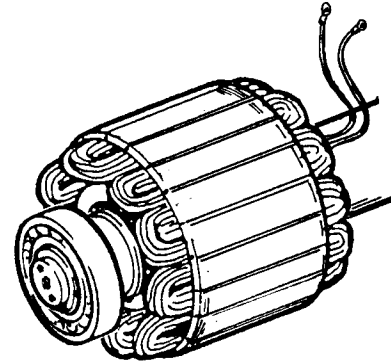

**EXCITER ARMATURE**

# ALTERNATOR ASSEMBLY

## ROTOR

### SCR MODULE

The SCR Module rectifies the AC output of the Exciter Armature and supplies this DC to the Main Generator Field (Rotor).

Three different modules accommodate the three FR alternator sizes.

The Module contains (2) SCR's and (2) Diodes connected in a bridge configuration. A free wheeling diode and varistor are connected across the output (F+ F-) to protect the bridge.

Controlled gating or triggering signals for the SCR's are received from the Photo-Transistor board and applied to terminal G. Two current limiting resistors protect the gating circuit.

All components are encapsulated for protection against the elements and vibration.

The individual components can be accessed for bench checking by referring to the schematic drawing.

**When checking components or resistance values on modules with stud type terminals, install and tighten a nut snugly against the board foil to insure a good mechanical connection to the foil circuit. The studs are not soldered to the foil.**

The F- terminal is connected to ground through the heatsink and mounting screws.

Weight plates are attached to the opposite rotor pole piece for counter balance.

Lead terminal screws are torqued to 8 in. lbs. All leads must be securely tied to the shaft to prevent movement due to centrifugal forces.

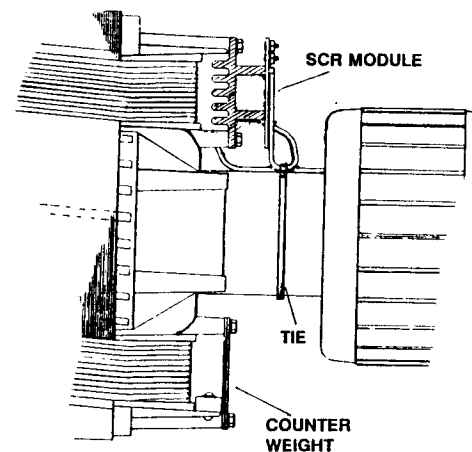
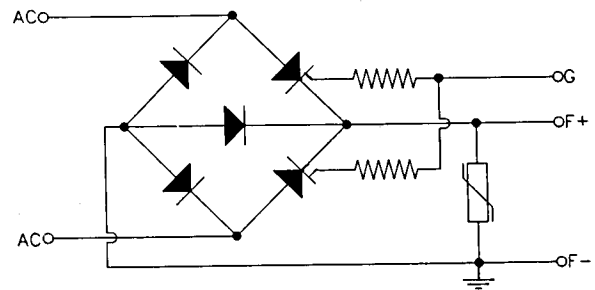
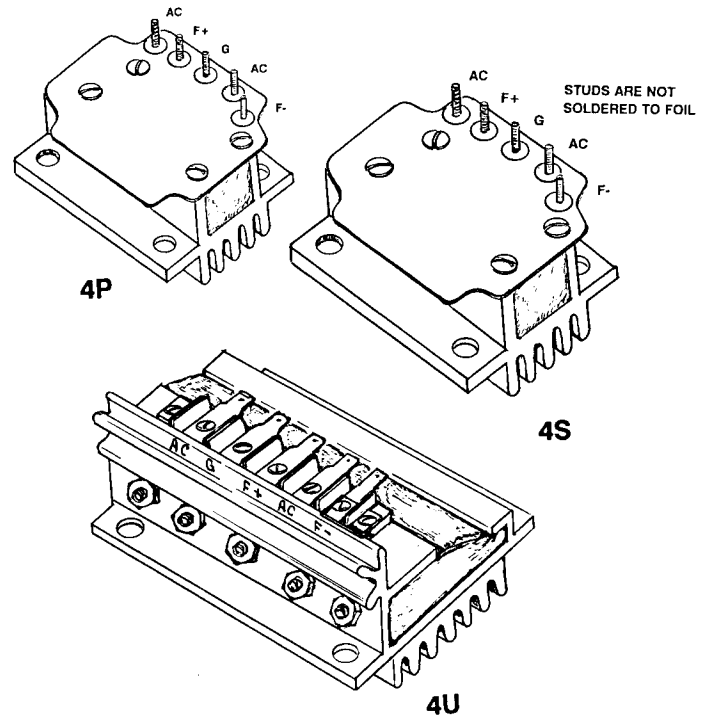

# ALTERNATOR ASSEMBLY

## ROTOR

### PHOTO TRANSISTOR BOARD

The photo transistor circuit board is the receiving portion of the photo coupling circuit and provides the gating signal to the SCR module.

The frequency of the output signal is dependent on the "on-off" light signal it receives from the stationary light emitting diode.

An insulated board and washers are sandwiched between the circuit board and the speed sensing actuator cup. The assembly is mounted to the rotor shaft by two screws.

The circuit board leads are fed through a drilling in the shaft and the exciter armature core and attached to the SCR module terminals.

Polarity of the G (green) and F3 (red) must be observed. **G to G, F3 to F+.**

A flashlight can be used as a light source to activate the photo-transistor for testing or troubleshooting.

**Do not operate the generator with the protective cover removed without guarding from external stray light sources which could cause a ceiling output voltage from the generator.**

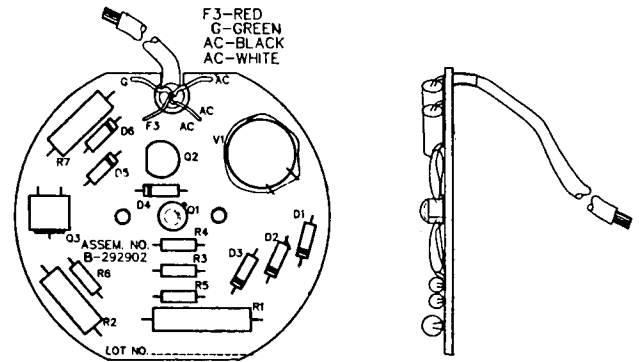
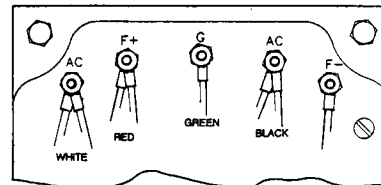
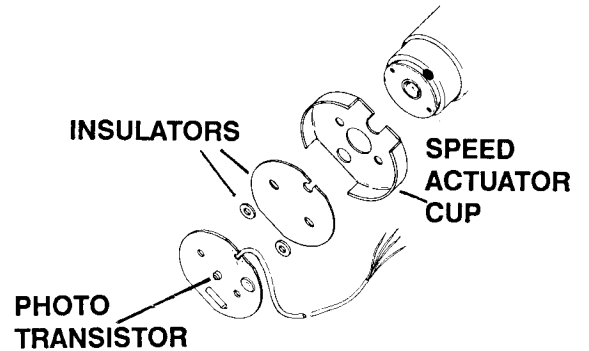
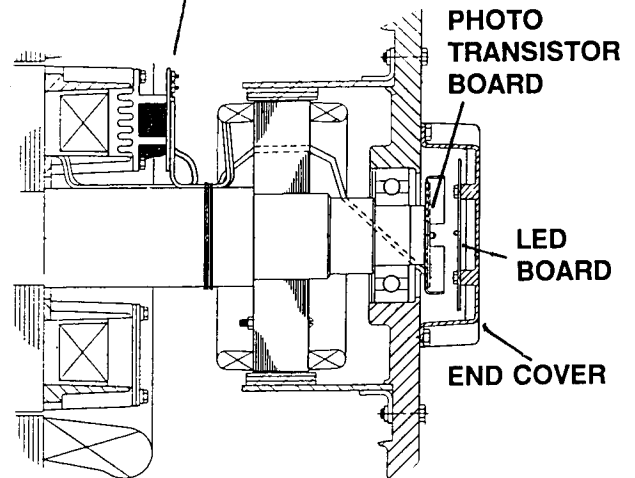

PHOTO TRANSISTOR BOARD



SCR MODULE





# ALTERNATOR ASSEMBLY

## LED BOARD

The LED board provides the light source to the photo transistor for triggering of the SCR's. It contains a light emitting diode (D1) and freewheeling diode (D2) as a protective component.

The LED is the stationary member of the photo coupling circuit and is mounted in a protective cover directly in line with the receiving photo transistor.

The LED emits an infrared signal which is invisible to the eye but has excellent ability to penetrate any dirt or grime which could accumulate over a period of time.

Voltage regulator output to the LED is a square wave and placed at terminals 5B and 3B of the P1 connector. "On" time will increase as load increases.

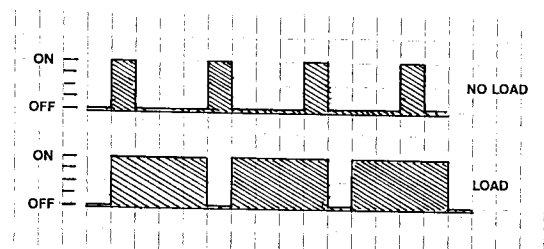
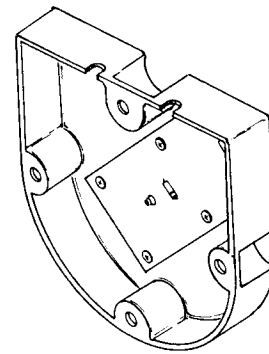
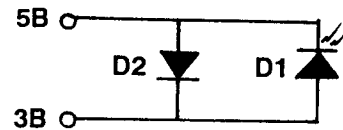
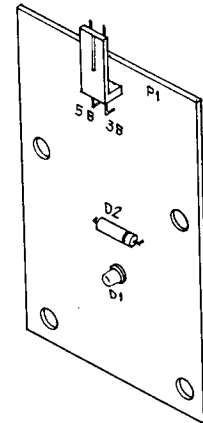

# ALTERNATOR ASSEMBLY

## VOLTAGE REGULATOR

The FR Voltage Regulator illustrated supplies the controlled power to the Light Emitting Diode and provides +/- 2% regulation.

Input power to the regulator is provided by the generator set starting battery. It will accept both 12 and 24 volt battery systems.

The battery (+) circuit is protected by a 15A fuse and supplied via a normally open K3 control relay contact. The controller relay is energized during engine crank and run.

An optional generator overload protection circuit breaker referred to as the Safe Guard Breaker will disrupt the regulator input power in the event of a prolonged overload.

Regulated output power to the photo coupling LED is 1 - 2 vdc at 100 Ma. Open circuit voltage is approximately 8 vdc.

The FR regulator is an average sensing regulator. A nominal single phase voltage sensing of 190 to 277 volts is monitored at generator terminals V7 - V8.

The regulator can be used for both 50 or 60 Hz operation depending on a jumper placement; T1 to T2 for 60 Hz, T1 to T3 or remove for 50 Hz.

The regulator is of the volts per hertz design. This feature causes the generator voltage to drop if the frequency falls below a preset level. (8 volts/hertz average). This allows the engine to regain RPM when large one step loads are applied. Factory cut-in frequency setting is 48 for 50Hz operation and 58 for 60 Hz operation. Settings can be field adjusted if required. The feature can be eliminated if necessary by turning the corresponding pot fully clockwise.

A Stability adjustment is provided for "fine tuning" and to minimize light flicker.

The 1000 ohm, 1 Watt voltage adjusting potentiometer is remotely mounted in the meter cabinet.

1% regulation and 3Ø sensing are optional.

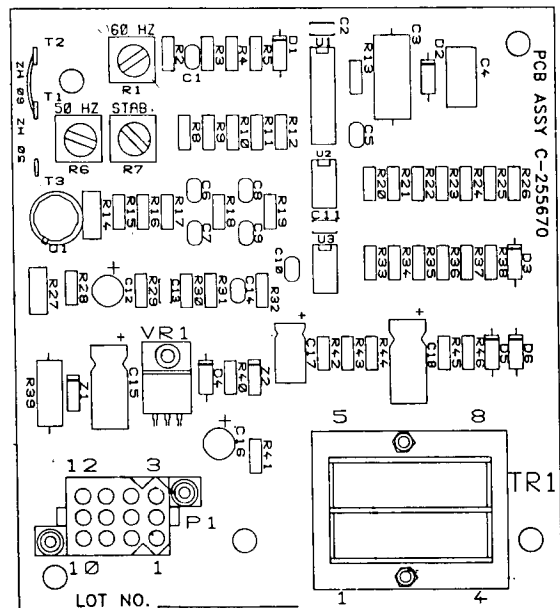
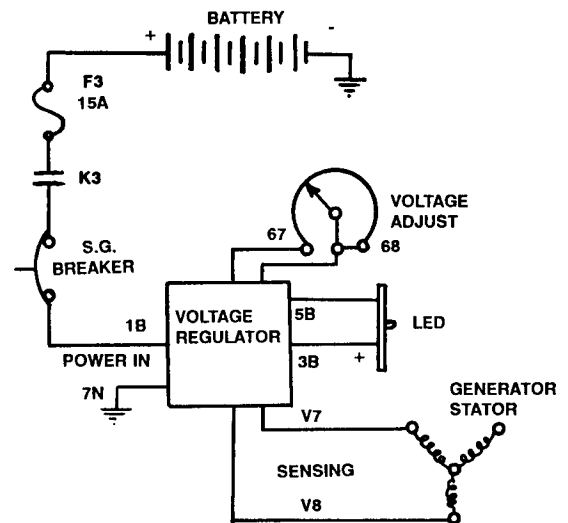
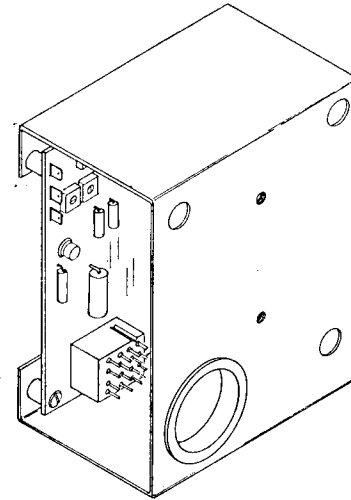

# ALTERNATOR ASSEMBLY

## VOLTAGE REGULATOR (3Ø)

A 3 phase voltage sensing regulator is available as an option for FR generator sets.

All features and specifications are the same as the 2% single phase sensing regulators provided as standard on FR generator sets.

Three potential transformers are located on the regulator which sense the generator phase to phase voltage at terminals V7, V8, and V9.

The 3Ø sensing will improve the generator performance in an application of unbalanced loads.

By monitoring the voltage across all three phases the regulator will sense the average and respond with more balanced overall regulation.

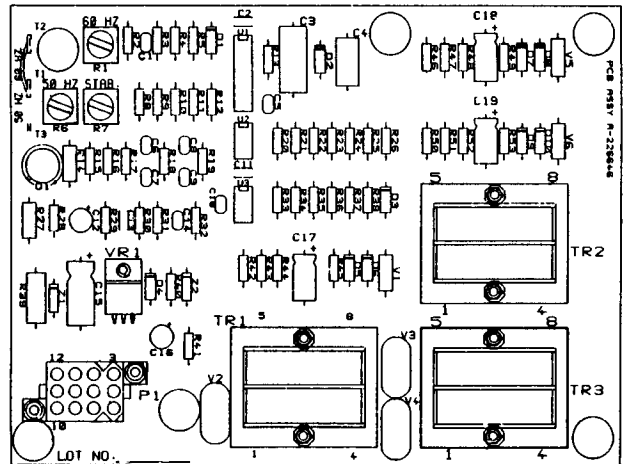

## FR REGULATION & EXCITATION

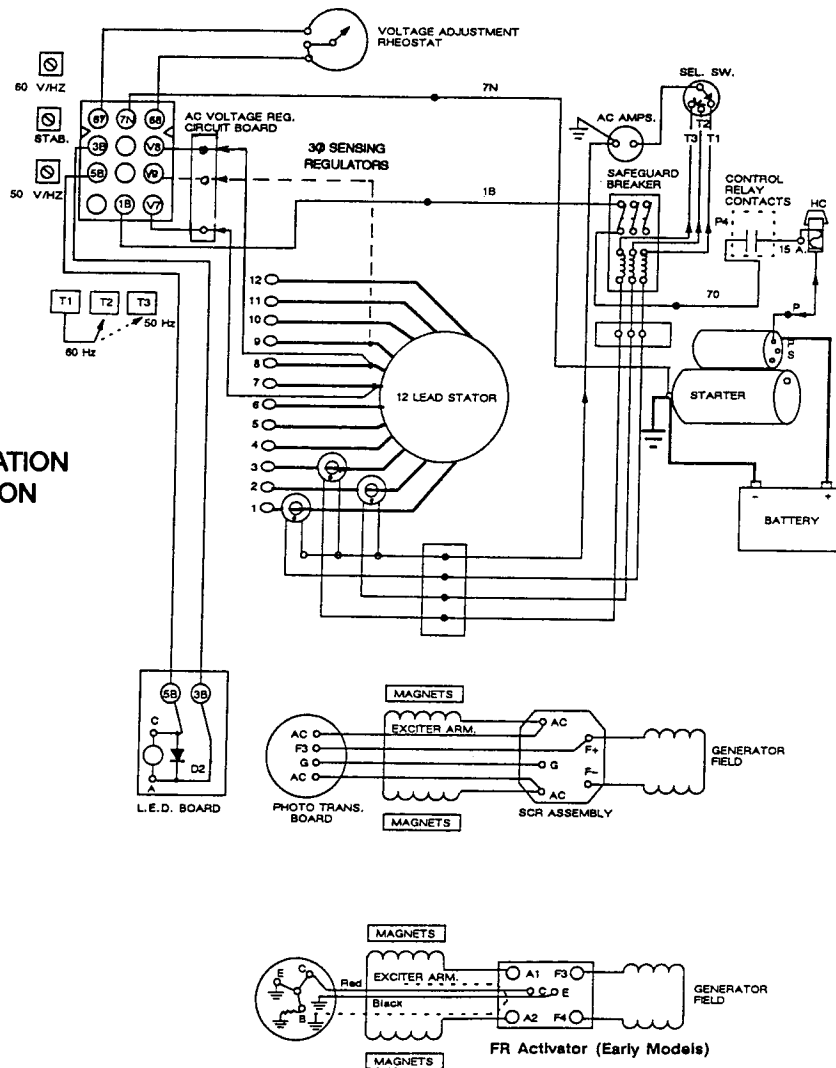



# ALTERNATOR ASSEMBLY

## GENERATOR ENCLOSURE

The four piece housings provide weather protection for the generator assembly. They also support the controller cabinet, contain various standard and optional controller and generator support components and provide isolation protection for the generator output connection terminals.

Customer electrical load connections are made inside the enclosure either to the generator line leads, or optional circuit breaker or bus bars. Component location may vary dependent on model size.

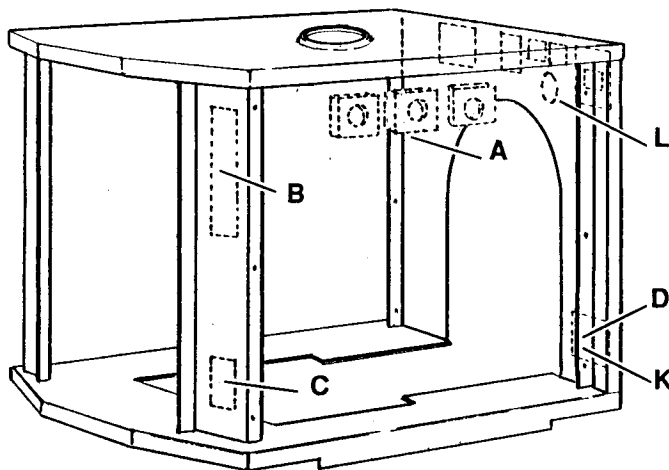
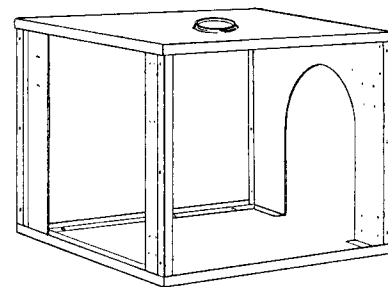
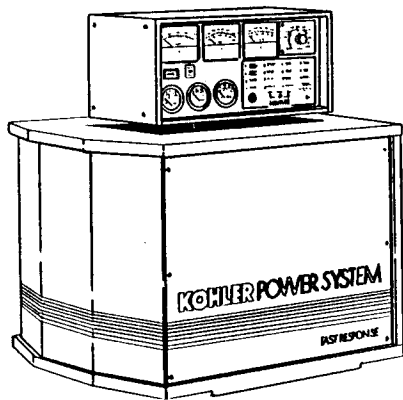
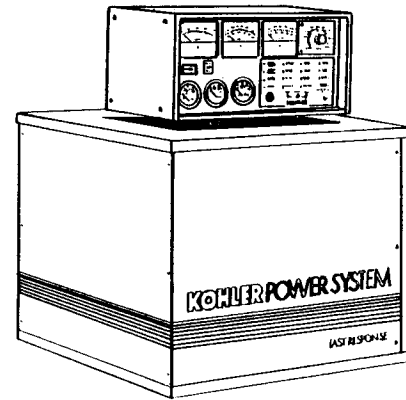

- A - CURRENT TRANSFORMERS
- B - CUSTOMER CONNECTION KIT
- C - COMMON FAULT RELAY
- D - SAFEGUARD BREAKER
- E - SAFEGUARD TERMINAL STRIP
- F - AIR DAMPER RELAY
- G - GOVERNOR RELAY
- H - RUN RELAY
- I - VOLTAGE REGULATOR
- J - LINE CIRCUIT BREAKER
- K - ELECT. GOVERNOR CONTROL
- L - DROOP COMP. RHEOSTAT

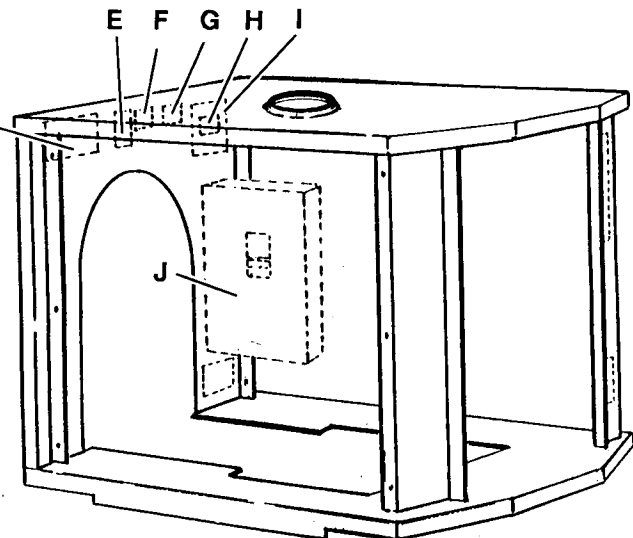

# ALTERNATOR ASSEMBLY

## LINE CIRCUIT BREAKER (Optional)

The Line Circuit Breaker provides an automatic disconnect if a fault in the circuit supplied by the generator causes a current demand greater than the preselected overcurrent value. (Usually the rating of the generator). It also allows for manually isolating the generator from the load.

The breaker mechanism is spring loaded when the contacts are closed and can therefore be easily tripped to the open position. This spring action also provides for quick making and breaking of the contacts. The design allows for contact tripping even if the toggle handle is held or blocked in the "ON" position.

When the mechanism has been tripped the operator handle will be positioned midway between "ON" and "OFF" providing a visual indication of a trip caused by a fault. The handle must be moved to the "off" position for resetting before it can again be latched in the "on" position.

Common methods of activating the trip mechanism are by thermal, magnetic and shunt devices or combinations of these.

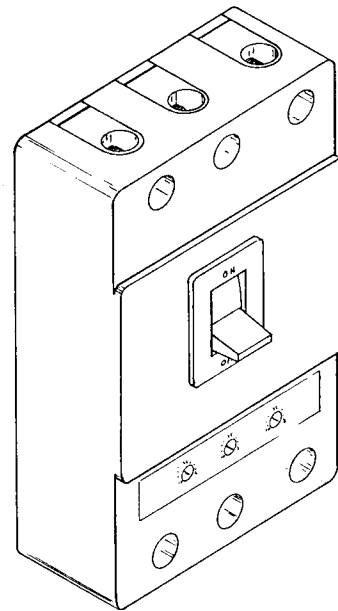

TYPICAL 3 POLE MOLDED CASE BREAKER WITH ADJUSTABLE MAGNETIC TRIPS.

## THERMAL TRIP

The thermal portion consists of a bi-metal strip which reacts to the heat produced from the load current. Excessive current will cause it to bend sufficiently to trip the mechanism. The trip delay is dependant on the duration and excess of overload current. Elements are factory calibrated.

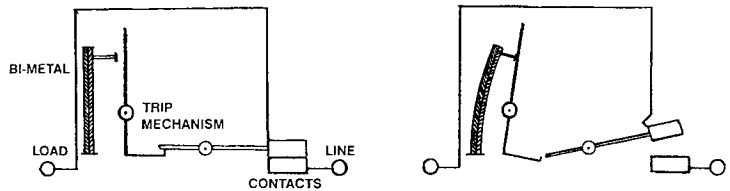

THERMAL TRIP

## MAGNETIC TRIP

The magnetic trip portion features an electro-magnet in series with the load contacts and a moveable armature to activate the trip mechanism. When a sudden excessive current such as a short circuit occurs the electro-magnet attracts the armature resulting in an instantaneous trip.

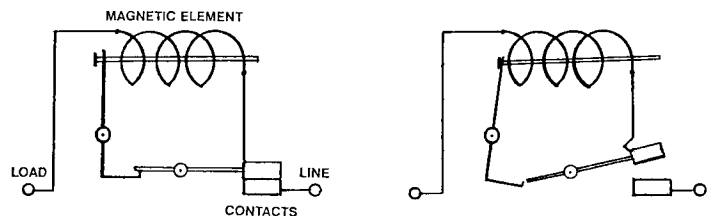

MAGNETIC TRIP

Magnetic elements with either fixed or adjustable trip points are available.

# ALTERNATOR ASSEMBLY

## LINE CIRCUIT BREAKER (Optional)

### THERMAL MAGNETIC

Most breakers utilize both bi-metal and electromagnetic devices to activate the tripping mechanism.

A combination of both thermal and magnetic allows a delayed trip on an overload and an instantaneous trip on a short circuit.

### SHUNT TRIP

A Shunt trip option provides a 12 or 24vdc solenoid within the breaker case that when momentarily energized from a remote location will activate the trip mechanism. This allows the breaker to be tripped by customer selected faults such as a generator overvoltage or overspeed.

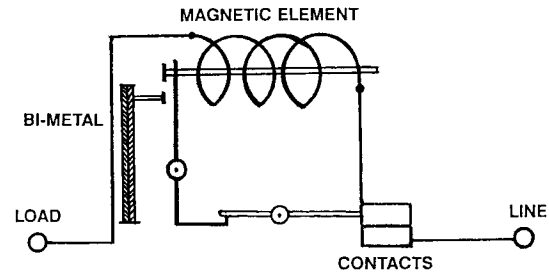

**THERMAL MAGNETIC**

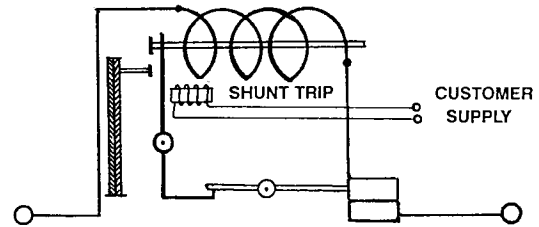

**THERMAL MAGNETIC WITH SHUNT TRIP**

# ALTERNATOR ASSEMBLY

## SAFEGUARD BREAKER

(optional)

The FR excitation circuit is designed to allow the generator to deliver in excess of 600% of rated output amperage and sustain a minimum of 300%. This feature allows for tripping of line breakers feeding an overload or short without disruption to remaining branch circuits.

If the line protection does not trip in the allotted time the Safeguard Breaker will provide protection for the generator.

As illustrated in the adjoining chart, a fault causing 400% of rated current to flow will allow 5 to 20 seconds for the branch circuit protection to open prior to tripping of the Safeguard Breaker.

Current transformers are used for both sensing and supply to the trip elements of the breakers.

The current transformers supplying the panel ammeters are connected in series with the breaker trip elements. A series of breakers are used to accommodate the FR sizes. Ratings range from 3.0 to 5.0 amperes.

All three phases of the generator are monitored, the breaker toggles are tied together to allow opening of the breaker contacts if current in any leg exceeds the trip rating.

Opening of the breaker contacts removes the battery supply from the voltage regulator, disrupting the photo coupling circuit, causing the main field to collapse.

**It must be realized that a residual voltage will be present at the main generator load terminals with the safeguard breaker open.** This is due to the magnetism remaining in the rotor iron.

**THE SAFEGUARD BREAKER IS NOT A LINE BREAKER.**

Breaker contacts are rated at 50 amperes.

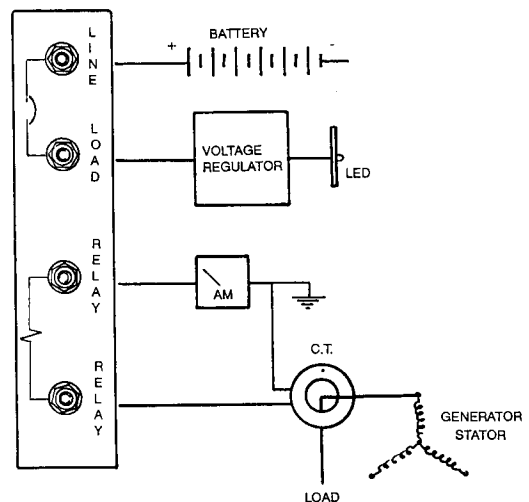
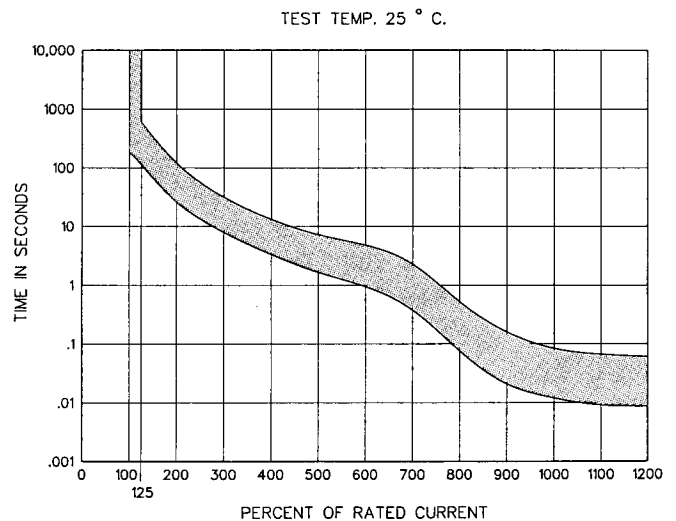
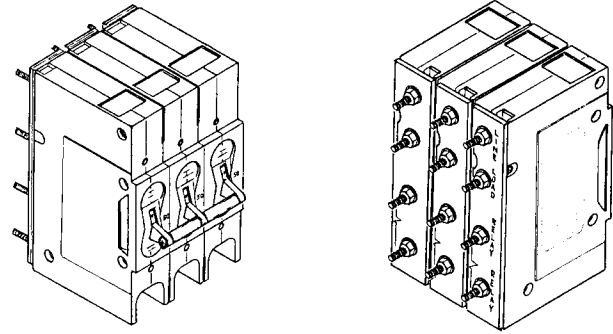

### SAFEGUARD BREAKER cont'd

The circuit breaker used is a viscous damped magnetic trip breaker with separate contact and trip circuits.

The current being monitored will draw the plunger against the core spring to a proportional position in the core tube.

When current exceeds the trip rating the plunger will touch the pole piece increasing the magnetic flux enough to attract the trip armature and open the contact circuit.

The core tube is filled with a silicon fluid which delays the speed of the plunger.

Delay time is selected by the viscosity of the fluid used.

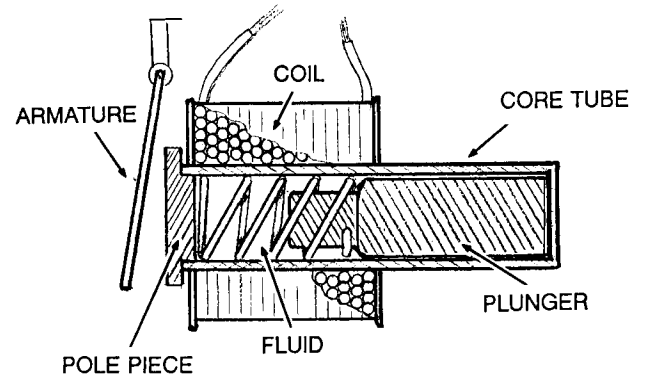
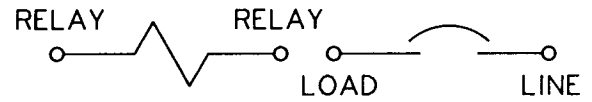

# ALTERNATOR ASSEMBLY

## SAFEGUARD BREAKER TERMINAL STRIP

The 6 terminal barrier strip located in the generator enclosure provides an interconnection point between the Current Transformer secondaries the Voltage regulator battery supply and the optional Safeguard breaker terminals.

System battery voltage to the Generator voltage regulator is provided at terminals 70 (+) and 7N (-). This circuit is protected by the Decision Maker 15 Amp fuse. Various optional devices may also be found connected to these terminals:

- Run Relay
- Water Level Switch
- City Water Cooling Solenoid
- Elect. Governor (Gas Models)

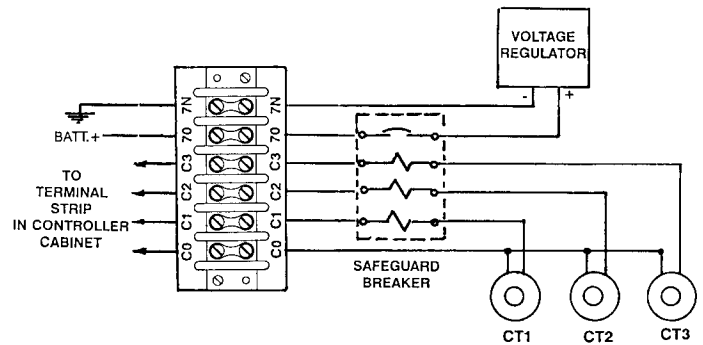

# ALTERNATOR ASSEMBLY

## CURRENT TRANSFORMERS (CTs)

Current Transformers allow the use of low amperage (5A) meter movements and trip mechanisms when monitoring high AC amperage flow.

When an AC load carrying conductor is placed through the core of a CT a proportionate current will be induced in the secondary winding surrounding the core.

Transformers are rated by ratio between their primary and secondary and are matched to the full scale of the ammeter they are supplying; a transformer with a 100:5 ratio is matched to a 0-100 Amp full scale ammeter. A current flow of 100 amps through the primary will produce 5 amps to the meter movement from the secondary and indicate 100 amps ( Full Scale) on the meter.

On models featuring the optional Safeguard Breaker, the CT's also provide the current for the trip elements.

Polarity markings for both the primary and secondary are usually indicated by a colored dot or H1 for the primary and a white lead or X1 indication for the secondary.

On Three phase units three CT's are required and generator leads must be routed through the transformer (primary) in the same direction. The dot or H1 side is toward the generator.

The white or X1 secondary leads connect to the SG breaker trip elements or C1, C2 and C3 terminals for meter phase selection. The remaining terminal or black leads are tied together and ground.

**DANGER ! DO NOT OPERATE THE GENERATOR SET UNDER LOAD WITH THE TRANSFORMER SECONDARY TERMINALS DISCONNECTED OR OPEN CIRCUITED. HIGH VOLTAGES INDUCED, COULD CAUSE SERIOUS INJURY OR DEATH.**

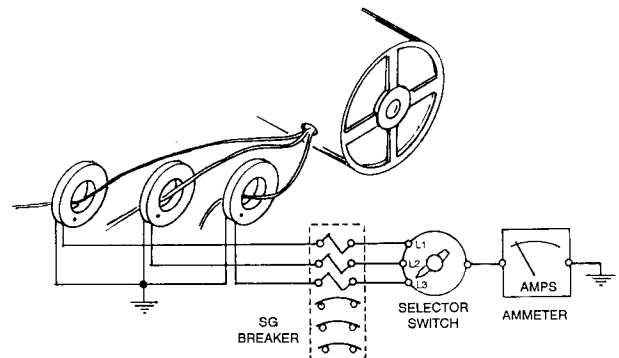
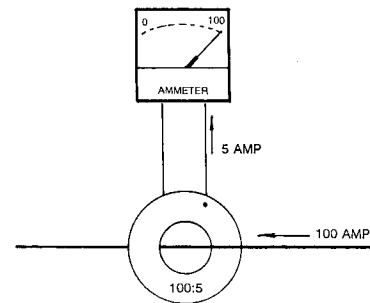
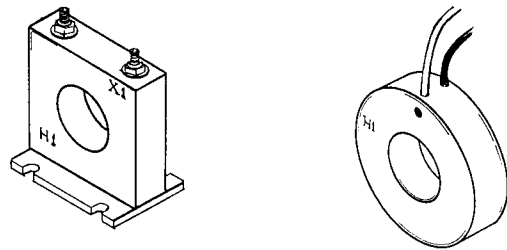

**CURRENT TRANSFORMERS (CTs)**

**ALTERNATOR ASSEMBLY**

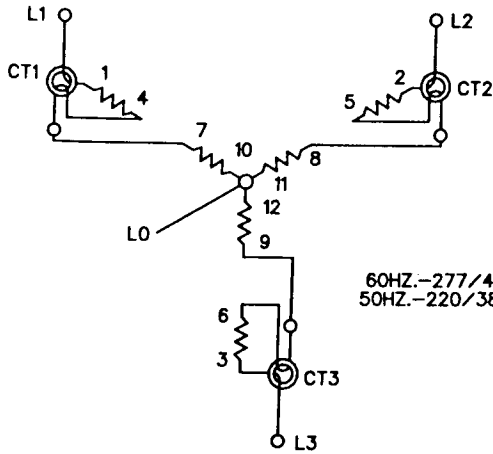

60HZ.-277/480V.-3 PH. 4 WIRE HIGH WYE  
 50HZ.-220/380V.-3 PH. 4 WIRE HIGH WYE

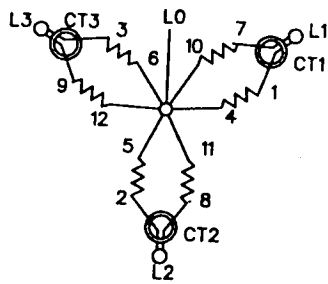
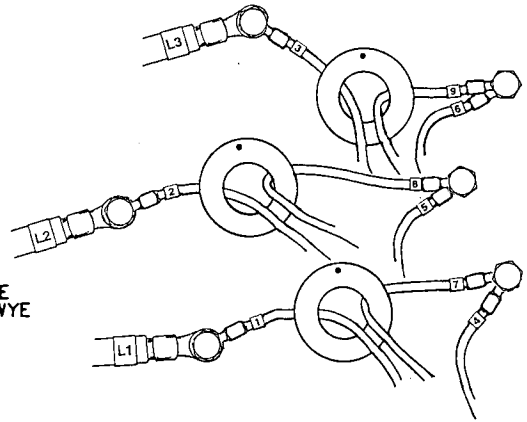

60HZ.-120/208V. OR 139/240V.  
 3 PH. 4 WIRE LOW WYE  
 50HZ.-120/208V. OR 110/190V.  
 3 PH. 4 WIRE LOW WYE

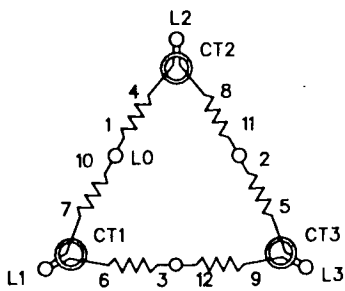
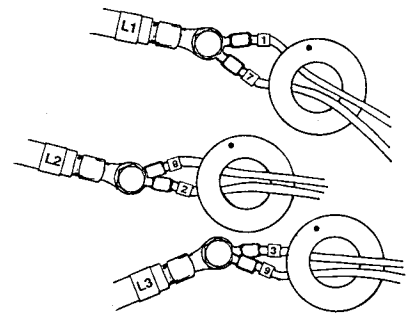

60HZ.-120/240V.-3 PH. 4 WIRE DELTA  
 50HZ.-110/220V.-3 PH. 4 WIRE DELTA

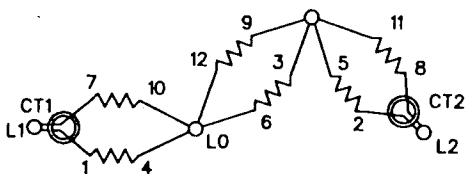
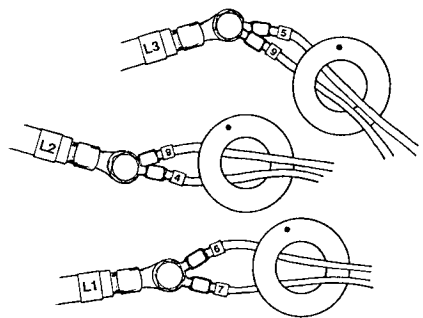

60HZ.-120/240V.-1 PH. 3 WIRE  
 50HZ.-110/220V.-1 PH. 3 WIRE  
 USED ON GENERATORS 20KW-100KW ONLY.

CT3 - NOT USED

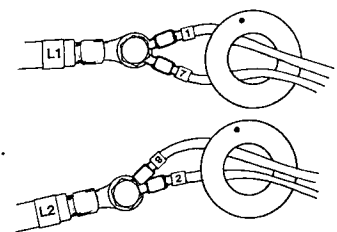



# ALTERNATOR ASSEMBLY

## REACTIVE DROOP COMPENSATOR (optional kit)

The Reactive Droop Compensator Kits contain a current transformer with a current ratio selected per the Generator size and a 16 ohm, 100 Watt rheostat common to all kits.

When generators are connected in parallel, governors control the engine power so each generator carries its proportionate share of the total load. The generator field excitation or reactive load however may be less or greater on one unit than another. This is because the individual voltage regulators all sense the same common bus voltage and cannot detect excitation voltage or reactive loads assumed by the other generators.

Imbalance of these reactive loads result in circulating currents (cross current) between the generators.

To minimize this effect a compensation circuit is used to balance the reactive loads by supplying an error signal to the voltage regulator.

Generator load current is directed through the transformer primary. The secondary is connected across the resistive burden (rheostat) and a generator phase which is 90 degrees out of phase with the primary. On inductive loads the CT secondary will induce a voltage across the resistor which is proportional in magnitude and in phase with the line current. This voltage is vectorially added to the voltage regulator sensing voltage to produce an error signal resulting in a droop in output voltage .

The regulator of another generator connected to the same load will sense the decrease in voltage and increase its excitation therefore keeping the bus voltage constant.

On non inductive loads the transformer primary and secondary current remain approximately 90 degrees out of phase therefore adding very little increase to the sensing signal.

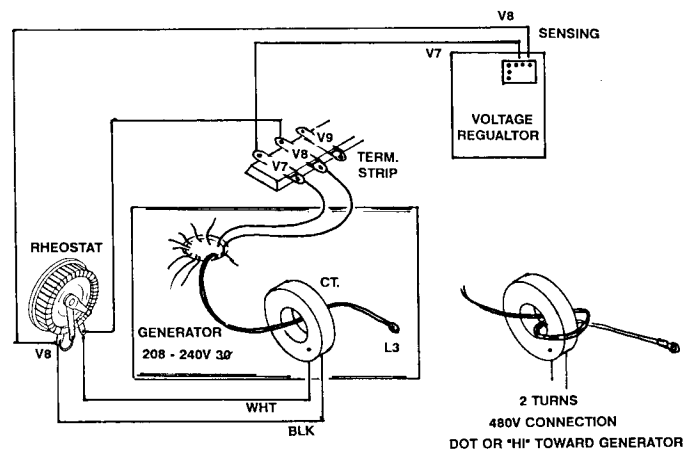
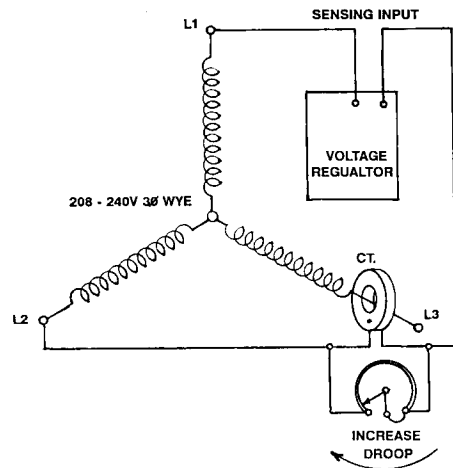
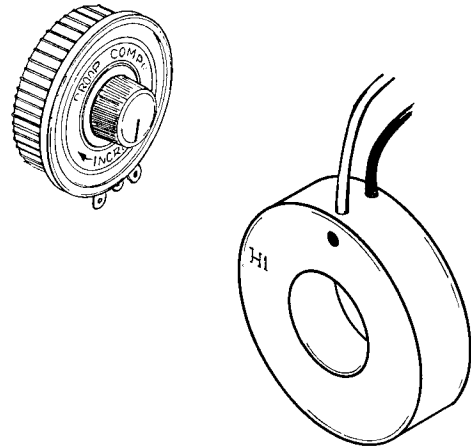

TYPICAL FRII KIT CONNECTION

# ALTERNATOR ASSEMBLY

## REACTIVE DROOP COMPENSATOR ADJUSTMENT:

1. With the compensator rheostat set at minimum resistance (CCW), record the RPM and voltage at 1/4 load steps to full load on unit #1. Repeat for unit #2.
2. Compare the readings and make final regulator and governor adjustments so that the voltage is within 1 volt at each load step and the speed is within 1 hz for each unit.
3. Check Droop Compensation on each unit as follows:
  - a. With unit #1 operating at the correct speed and voltage, apply a lagging power factor load. This load should preferably be 1/2 to full load and must be inductive.
  - b. Observe the voltmeter on unit #1 with the rheostat set at minimum. As the rheostat is turned CW the voltmeter should show a decrease in voltage. If a larger voltage is obtained when the rheostat is turned CW, shut down the system and reverse the direction of the generator load line through current transformer, or reverse transformer leads. Recheck droop.
  - c. Set the rheostat at a value which is approximately 4% of rated voltage at full load. As an example, the voltage will droop (decrease) 19.2 v on a 480 volt system at full load or 9.6 volts at 1/2 load. To determine droop at other than full load, use the following formula:  
  
$$\frac{\text{Rated Voltage}}{\text{Voltage}} \times .04 \times \text{Actual Load}^* = \text{Voltage Droop}$$

\*(expressed as a % of full load)
  - d. Repeat Steps a, b, c for unit #2 and be certain the amount of voltage droop is equal at the same load point as on unit #1.
  - e. With this procedure, the two units will share reactive currents proportionately.

4. In addition to Steps 1-3, it is desirable to use the following procedure to check that the units are sharing the reactive load correctly.

- a. Parallel the units at one-half to full load. Check the wattmeters to determine that each unit is carrying equal KW load or a load proportional to its capacity. If the loads are incorrect, adjust and recheck the governor throttle control to correctly balance loading.
- b. with the load balanced, check the ammeters to see that equal current is being produced or the current is proportional according to capacity. If the currents are incorrect, adjust the droop rheostat to reduce the current of the unit that has the highest reading. The current should be reduced to an equal division or be proportional.

As a result of performing Steps a and b, the governors have been adjusted to balance load and the Droop rheostat has been adjusted to balance current. These setting would be optimum for parallel operation.

### NOTE

Voltage must droop on lagging power factor loads (inductive loads). A small change in voltage is acceptable on unity power factor loads (resistive loads).

# ALTERNATOR ASSEMBLY

## AUXILIARY RELAYS (K5 & K6)

These relays are located in the generator enclosure when required. The relays are available with either 12 or 24 volt coils to match the system battery voltage.

A freewheeling diode is installed across coil terminals 85 and 86 for circuit protection. Polarity direction must be observed per the appropriate diagram.

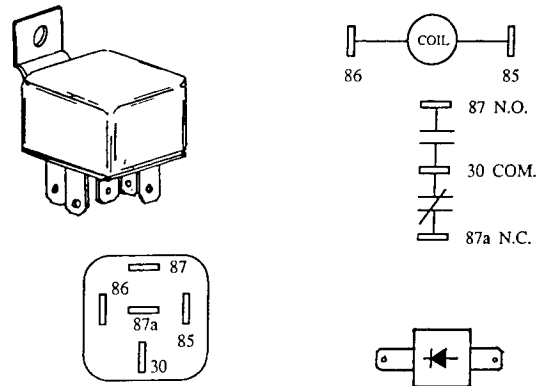

## GOVERNOR RELAY (K5)

The K5 relay is installed on units with Electronic Governors. It controls battery + voltage to the Governor Control.

The relay is energized during cranking and running by the K3 Decision Maker controller relay.

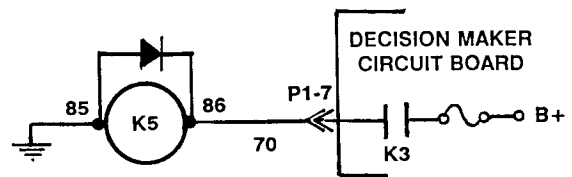

## AIR DAMPER RELAY (K6)

Damper valves which block off intake combustion air for immediate shutdowns are used on various engine models. The damper or linkage is actuated by a momentarily energized electric solenoid.

The K6 relay controls the energizing of the solenoid.

A ground output signal from the controller logic board due to an **Overvoltage, Overspeed or Emergency Stop** will energize the relay.

Movement of the Solenoid will also activate a micro switch to signal energizing of the Air Damper and Emergency Stop lamps on the controller Indicator Panel.

Once energized the damper will latch closed and must be manually reset prior to restarting.

The circuit is not energized during normal operational shutdowns or faults not considered emergency.

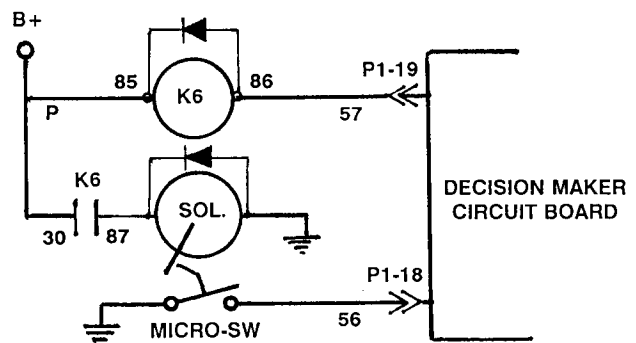
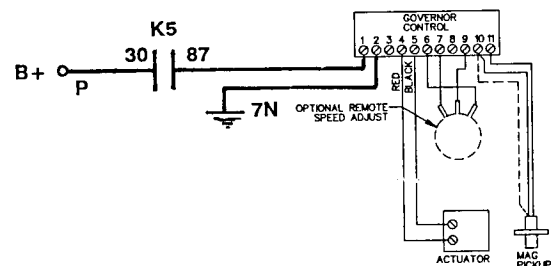

# ALTERNATOR ASSEMBLY

## GENERATOR ENCLOSURE

### RUN RELAY (OPTIONAL)

The Run Relay provides three sets of dry contacts for customer connection of devices required to be energized or deenergized when the generator set is being operated.. Louvers, Indicator lamps etc.

The three pole, double throw contacts of the relay illustrated have an Industrial rating of:

**3A. 1/3HP, 600VAC**

**10A. 1/2HP, 120VAC**

**6 2/3A. 1/3HP, 250VAC**

Appliance rated at 10A. 250VAC

Coil voltage is selected to match the Gen. set battery, (12 or 24VDC) and is supplied during cranking and running from the #3, 15A controller fuse. (terminals 70(+) & 7N(-) on the Safeguard terminal strip). The diode connected across the coil provides protection to the control circuit components and polarity must be observed.

The relay when specified is located in the generator enclosure. On early models the relay was mounted on the voltage regulator cover. (A)

Customer connections are made directly to the relay terminals.

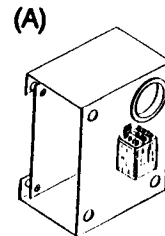
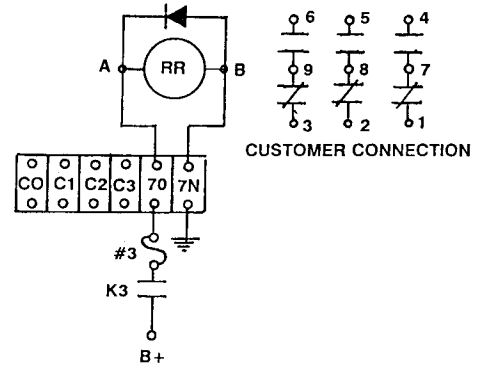
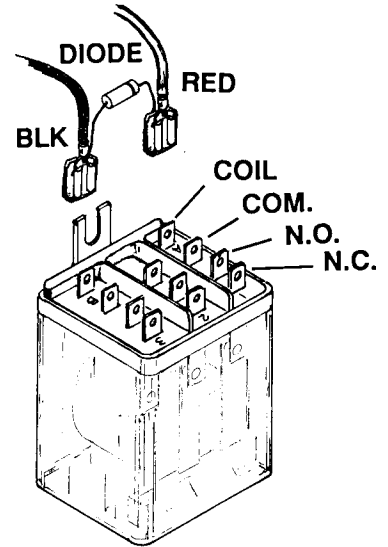

# CONTROLLER

## CONTROLLER CABINET

The control cabinet houses the generator set control circuitry and connection terminals. The vibration isolators are symmetrically located so the cabinet can be mounted to face the side or rear.

The rear panel is hinged to allow easy access to the microcomputer circuit board and customer connection terminals.

The face of the FR generator set controller cabinet is lit during operation and contains the generator voltage output adjust rheostat, AC metering system, Running time indicator, engine control switches and gauges plus an array of system condition indicators.

Meters, gauges and indicator panel are included in the controller and provided as standard on FR Generator Sets.

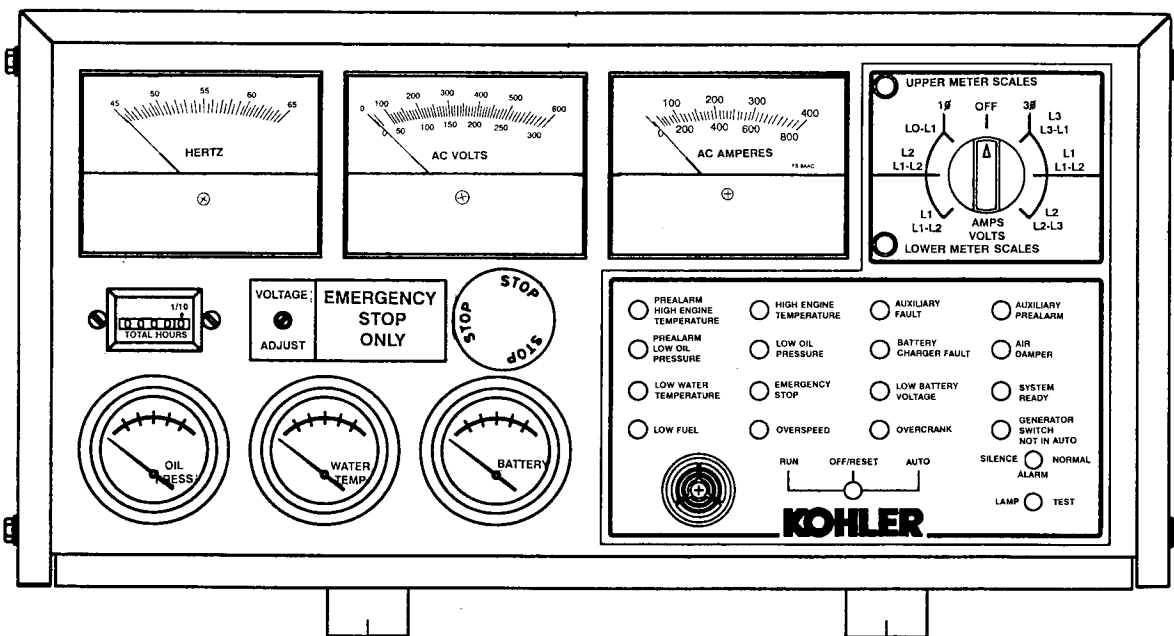
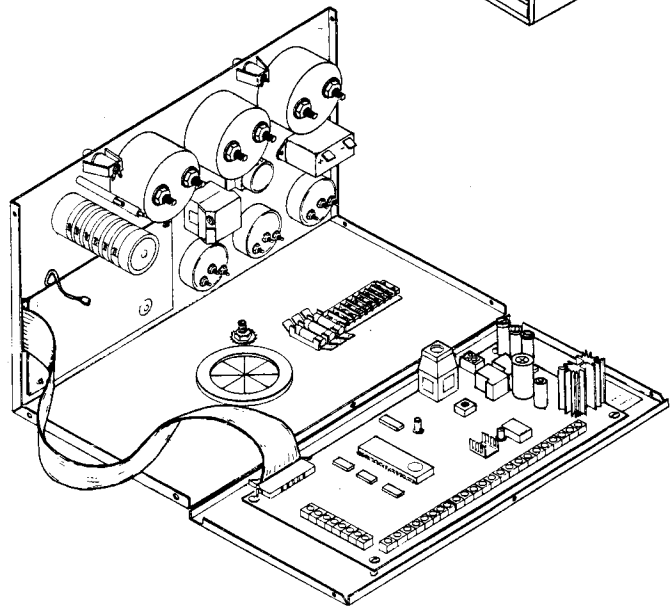
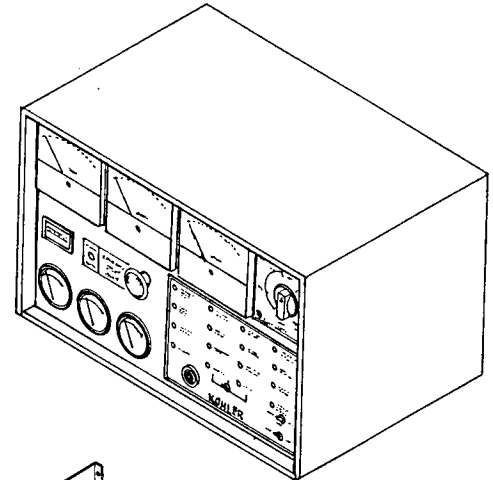

# CONTROLLER

Optional Controllers are available for Fast Response Generator sets to meet customers special needs.

Expanded cabinet boxes are required when optional AC Wattmeter, engine tachometer or oil temperature gauge are supplied.

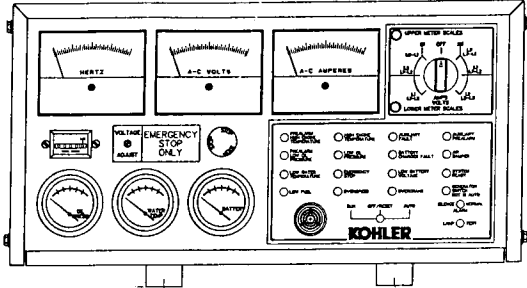

Standard 16 Light Microcomputer Controller.  
(Level 1) Meets NFPA-99 and 110.

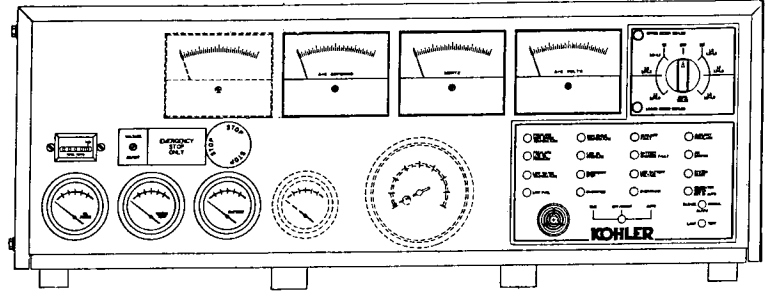

Expanded 16 Light Microcomputer Controller.

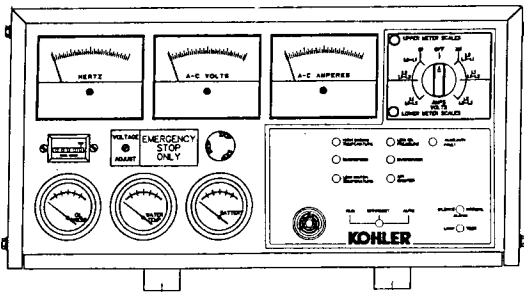

Optional 7 Light Microcomputer Controller.  
(Level 2)

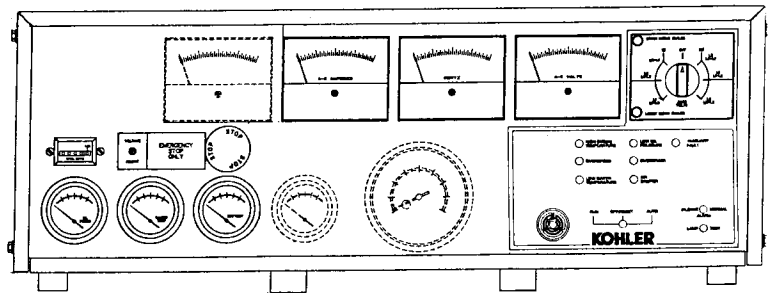

Expanded 7 Light Microcomputer Controller.

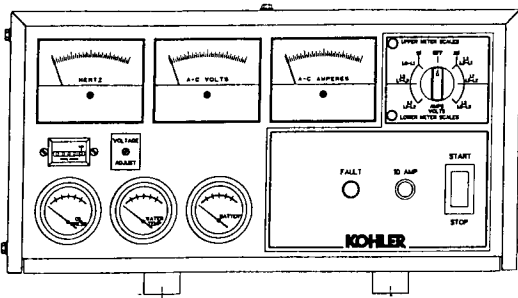

Optional Manual Controller.

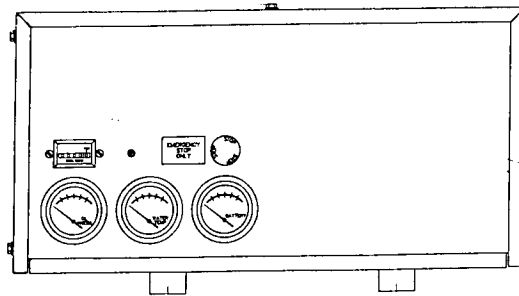

Paralleling Engine Gauge Box.

# CONTROLLER

## METERS

### VOLTMETER

A 3 1/2" dual scale voltmeter is used as standard for 12 lead generator models.

Upper scale is 0-600 the lower scale is 0-300. lamps on the meter selector switch plate will indicate which scale is to be read and is set at time of generator voltage connection.

The meters are calibrated to read full scale (FS) with 300 volts applied to the terminals and are rated at 2% FS.

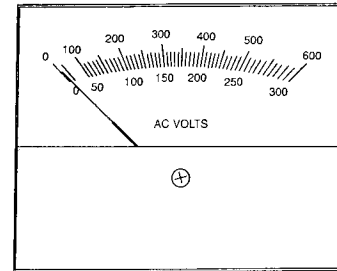

### VOLTMETER (600V Models)

A 0-900 scale voltmeter is supplied on the 600 volt non-reconnectable models. These meters also have a 300 volt full scale movement and sense the V7-V8-V9 stator taps. A 10W, 10K variable resistor is connected in series with a meter terminal and is used for calibration during final plant test.

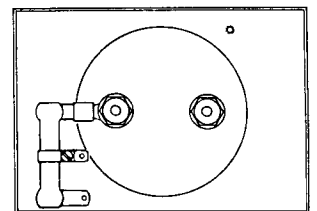
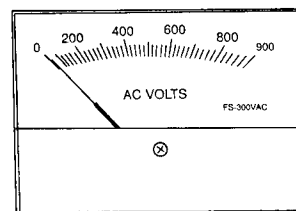

### FREQUENCY METER

The standard frequency meter used for both 50 and 60 Hertz models as well as 600V models is a 3 1/2" with a scale of 45 to 65 Hz. and a 120 vac .5% movement. The meter is connected to monitor stator leads V7 - V0.

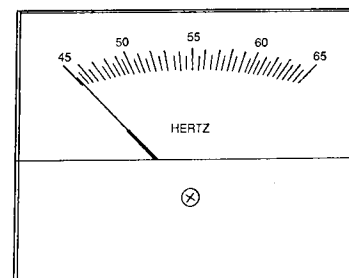

### AMMETERS

The ammeters are all dual scale meters and selected so one meter will cover all the standard voltage connections in a specific KW model range, except 600v. All ammeters have a 5 amp. full scale movement and are used in conjunction with current transformers.

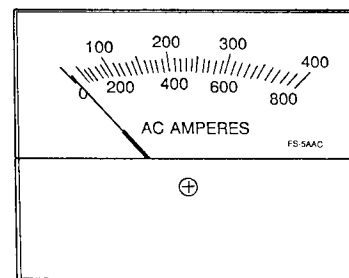

# CONTROLLER

## METERS

### WATTMETER (OPTIONAL)

Wattmeters are optional and require an oversized controller to house the transducer and wattmeter.

Both the AC voltage and current are monitored and supplied to the transducer which converts the AC power to a proportional DC output.

Illustrated is a typical 2 1/2 element transducer and diagram.

Input power is 120vac / 1 amp. Potential transformers are used on Delta and Hi Wye connections to provide the 120v.

Current transformers provide the current sensing. **Polarity and safety precautions must be observed.** Separate transformers are used from the standard meter CT's.

Output to the Wattmeter movement is 0 - 1mADC.

If a field voltage reconnection change is made on a gen set with wattmeter kit, a transducer or transformer change is required.

Transducers are selected to match the Generator KW rating.

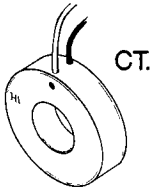
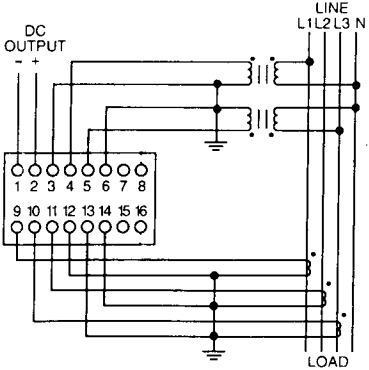
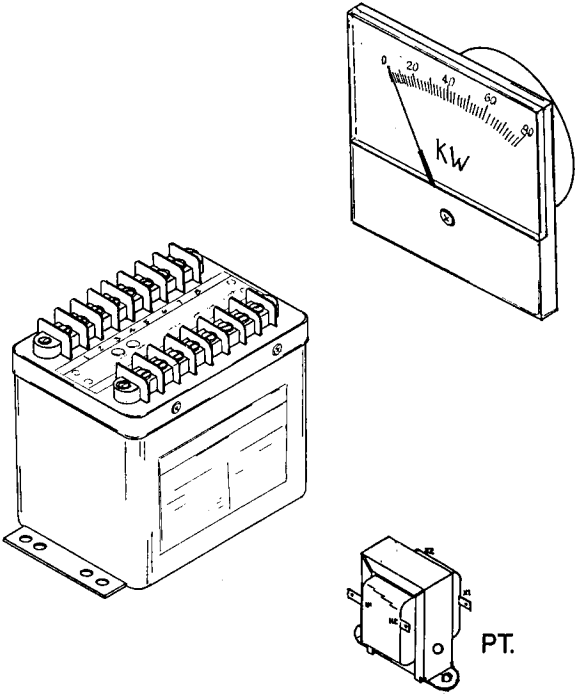



# CONTROLLER

## METER SELECTOR SWITCH

The Meter Selector Switch allows monitoring of the generator voltage and load amperage as indicated on the Nameplate.

Two meter selector switches and nameplates accommodate all FR models.

The switch terminal numbers and wiring are the same for both switches, however the internal switching sequencing differs.

One switch and nameplate, (A) is used on all FR generators up to 100 KW (Except 600v models) This is to accommodate the Single phase models available in this range.

The other switch, (B) is used on all models above 100 KW as well as all 600 volt models.

Twelve contacts are enclosed in the typical rotary switch illustrated. Six contacts for the ammeter and six for the voltmeter.

Terminals 1 to 12 are 'make before break' contacts and used to switch the secondaries of the CT's to the ammeter. They short the secondaries during switching between phases preventing the hazardous condition of an open CT secondary.

Contact terminals 13 to 24 control Line to Line and Line to Neutral sensing to the voltmeter.

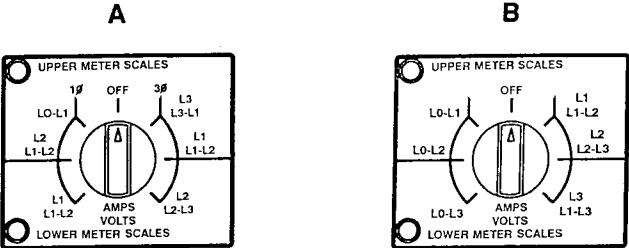
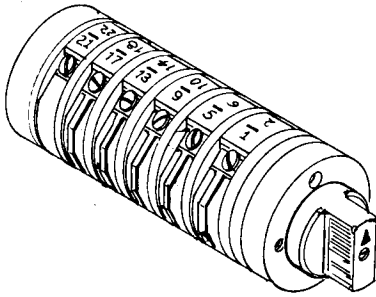

	L1 L1-L2	L2 L1-L2	L0-L1	OFF	L3 L3-L1	L1 L1-L2	L2 L2-L3	
1-0	M	C	C	C	M	M	C	2
3-0	C	M				M	C	4
5-0	C	M	M	C	C	C	M	6
7-0	M	C	M				M	8
9-0	C	C	C	C	M	M	C	10
11-0					M	C	M	12
13-0	C	C	C					14
15-0					C	C		16
17-0						C		18
19-0	C	C					C	20
21-0					C		C	22
23-0		C					C	24

NOTE:  
BLANK DENOTES CONTACT OPEN.  
"C" DENOTES CONTACT CLOSED.  
"M" DENOTES MAKE BEFORE BREAK CONTACT.

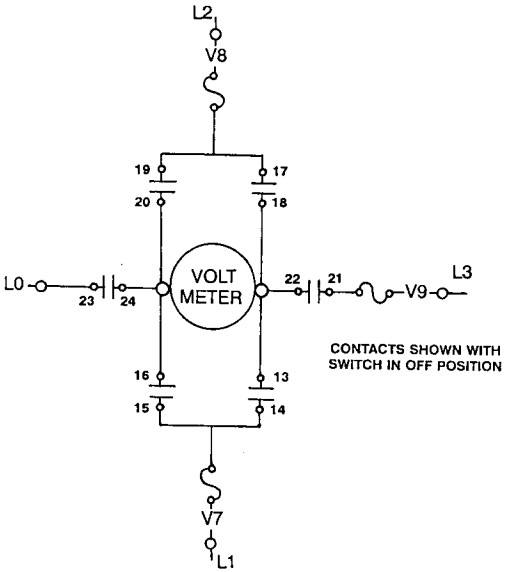
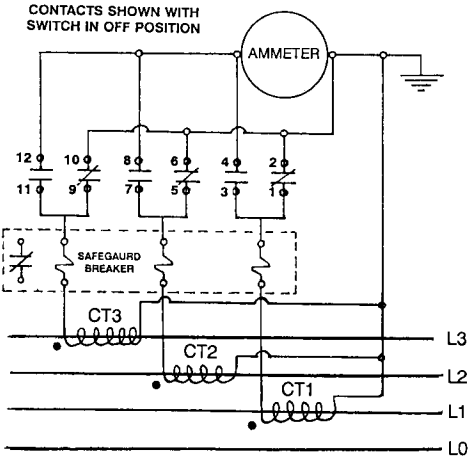

# CONTROLLER

## METER SCALE INDICATORS

Two 1/3 watt neon lamps located in the switch nameplate are connected to a terminal block and indicate which scale is to be read. Placement of a jumper provides 120 vac and determines the lighting of either the upper or lower indicator lamp. The lower scale is used on all voltage connections except 277/480 (220/380), and 600v.

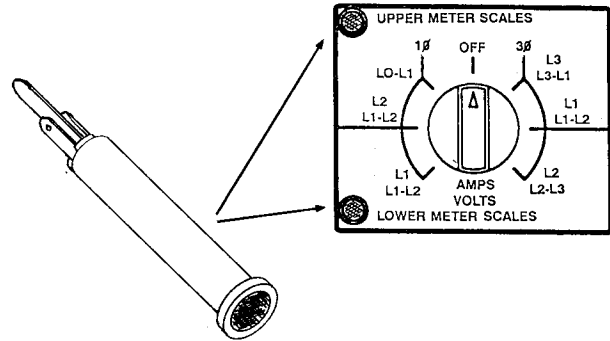

## METER TERMINALS AND FUSES

Stator coil leads 7, 8 and 9 (V7,V8,V9) are monitored and protected by 250v 1.5 amp terminal block fuses. Lead 10 is the neutral and designated as V0. Terminals C1, C2, and C3 are the X1 secondaries of the CT's, terminal C0 is the secondary common and is grounded.

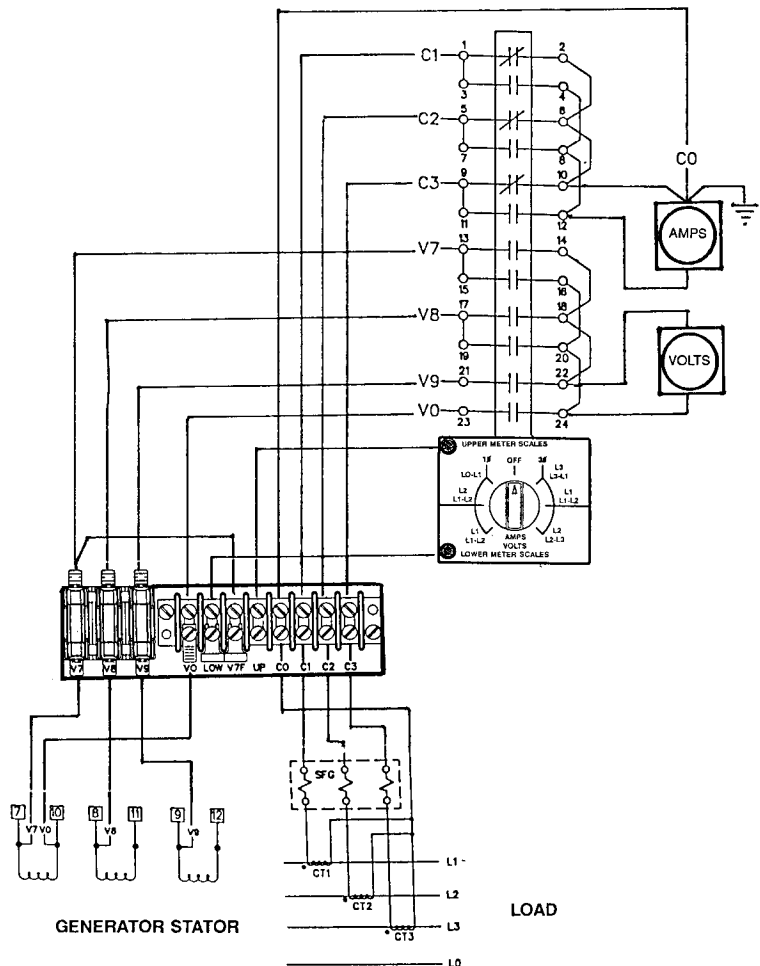
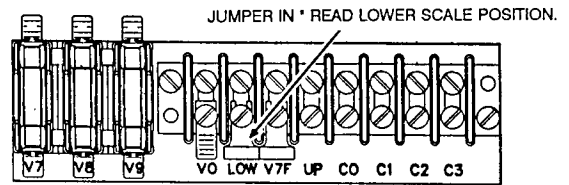

# CONTROLLER

## EMERGENCY STOP SWITCH (local)

Depressing the oversized red stop switch as does placing the "RUN - OFF/REST - AUTO" switch in the "OFF" position provides an immediate engine shut-down. It will override the 5 minute delayed shutdown which occurs when the unit is being controlled remotely and should only be used as an emergency stop switch.

This switch is standard on all Detroit Diesel powered units and optional on all other models.

This three piece switch consists of a latching plunger assembly, the mounting housing and the contact assembly.

Pressing the plunger button opens the normally closed set of contacts. The latching feature holds them in the open position until the button is manually rotated 1/4 turn clockwise which resets the assembly to its normal position.

The two mounting screws are accessed by first removing the contact assembly.

The switch contacts are wired to terminals 1 and 1A of the main control board terminal strip. A jumper must be placed between these terminals if a switch is not installed.

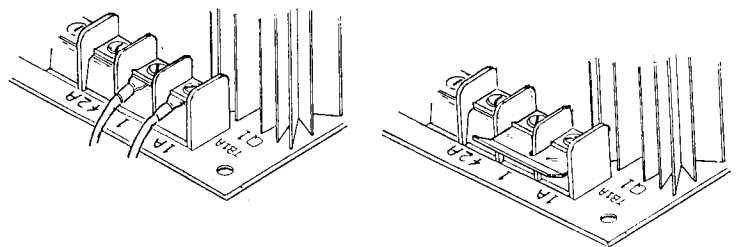
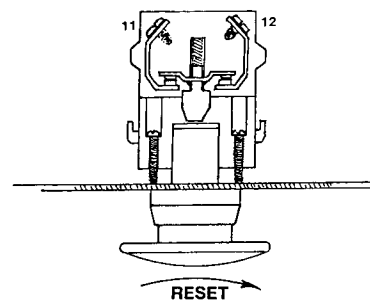
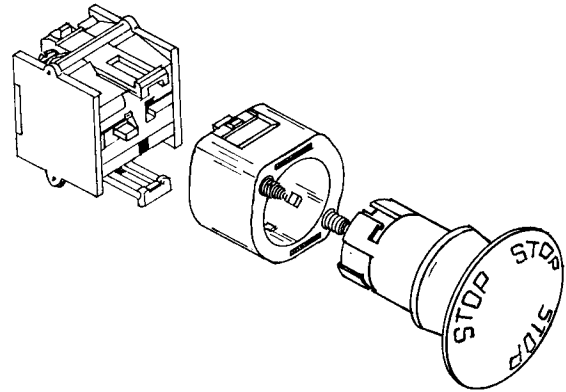

# CONTROLLER

## VOLTAGE ADJUST

The 1000 ohm, 1 Watt potentiometer allows customer adjustment to the generator output voltage a minimum of +/- 10% of the nominal generator voltage range.

The potentiometer is wired to the voltage regulator via an inline 2 pin connector.

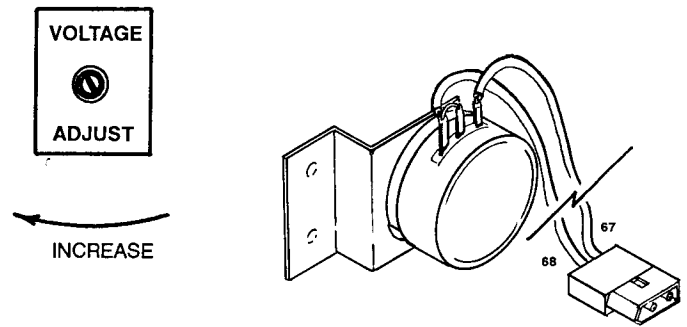

## HOURMETER

The hourmeter is used to record the total operating time of the generator set. It is energized with the engine gauges and panel illumination lamps from the F3, 15 amp fuse through the K3 control relay.

The typical style meter illustrated will accept DC voltages from 8-32 volts. Polarity to its terminals must be observed.

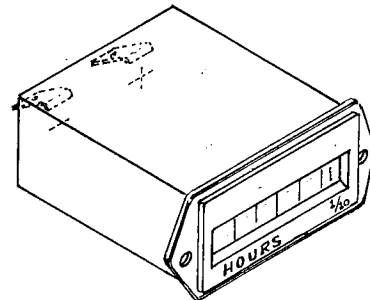

## PANEL LAMPS

Two #1815, (14v/2.8w) or two #313, (28v/4.8w) miniature bayonet lamps illuminate the standard front panel. Three lamps are used in the expanded box panel.

These lamps are energized whenever the generator set is operating and are powered by the set battery.(12 or 24vdc).

The circuit is protected by the F3 fuse.

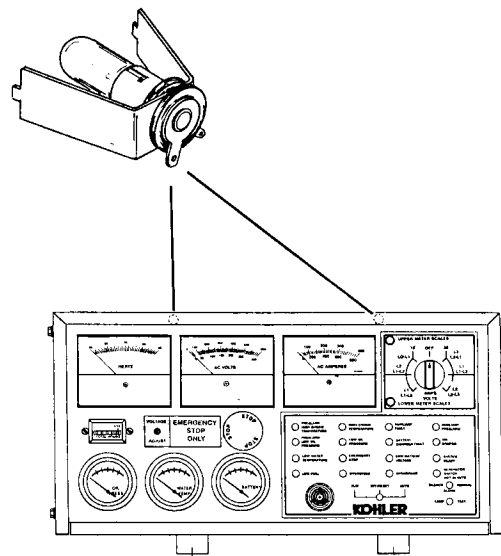

# CONTROLLER

## ENGINE GAUGES

Electric 2" English/Metric series gauges with International symbols for Oil Pressure, Coolant Temperature and Battery Voltage are standard in the FR Control Cabinet. They are rated at 2% FS accuracy.

The Voltage gauge monitors the battery charging system. Nominal charging voltage is between 13 and 15 on 12 volt units and 25 to 28 on 24 volt models during operation.

Variable resistance type senders for temperature and pressure are located in the engine block and matched to the gauge scale. Resistance value decreases with an increase in temperature or pressure.

The gauges are connected with the hour meter and panel lamps and powered through the F3 fuse.

A voltage dropping resistor is used in series with the standard 12VDC Oil Pressure and Temperature gauges when used on 24VDC systems. It is supported by an insulated bracket to the S terminal.

- G** terminal - Ground (-)
- S** terminal - Sender output.
- I** terminal - Ignition voltage (+)

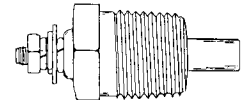
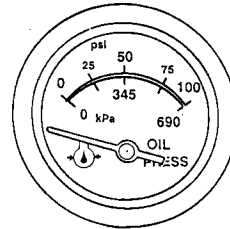
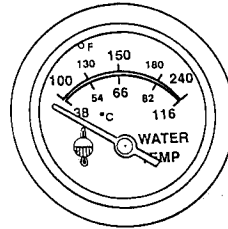
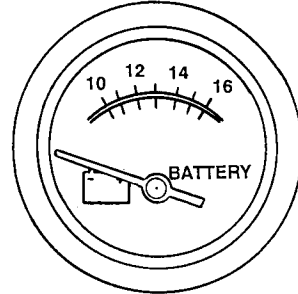

**TEMPERATURE SENDER**  
100°F = 450 ohms    240°F = 33 ohms

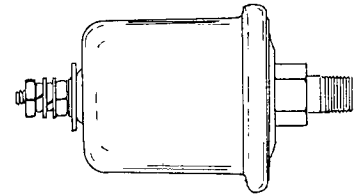

**PRESSURE SENDER**  
0 psi = 240 ohms    100 psi = 33 ohms

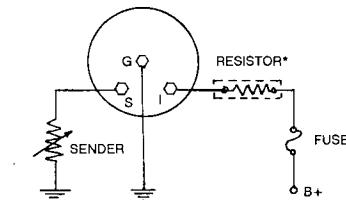
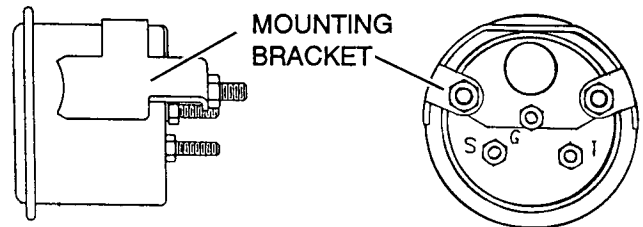

\*24v systems only

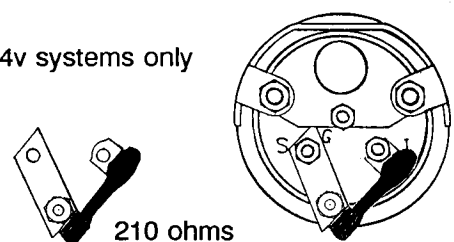

# CONTROLLER

## ENGINE GAUGES (OPTIONAL)

### OIL TEMPERATURE

An electric Oil Temperature gauge is available as an option and requires the expanded cabinet for installation.

It, like the coolant temperature gauge has a 12VDC movement and when used on 24v systems requires a voltage dropping resistor in series with the I terminal.

An increase in oil temperature will decrease the sender resistance value.

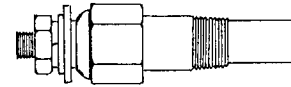
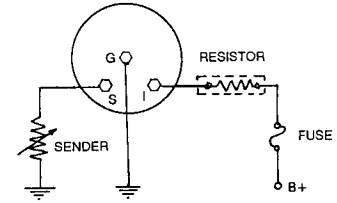
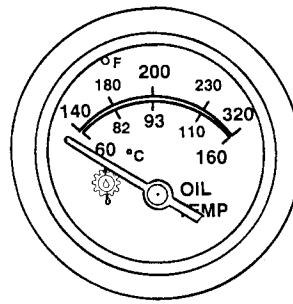

140°F = 350 ohms    320°F = 20 ohms

### TACHOMETER

The optional tachometer also requires an expanded controller cabinet for its installation.

The meter illustrated is an electronic tach and will operate on both 12 and 24 volt systems. The pointer will snap to "0" when voltage is applied at start-up.

The meter is adaptable to 4, 6, and 8 cylinder engines by a selector switch at the rear of the meter.

Impulse signal is provided from the "R" terminal of the engine driven battery charging alternator and is connected to the "S" terminal of the meter.

A calibration adjustment is provided and is required only at time of initial meter installation. This is accomplished with use of a hand-held tach or the frequency meter and a 5/16" or 2MM hex wrench.

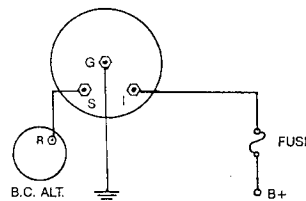
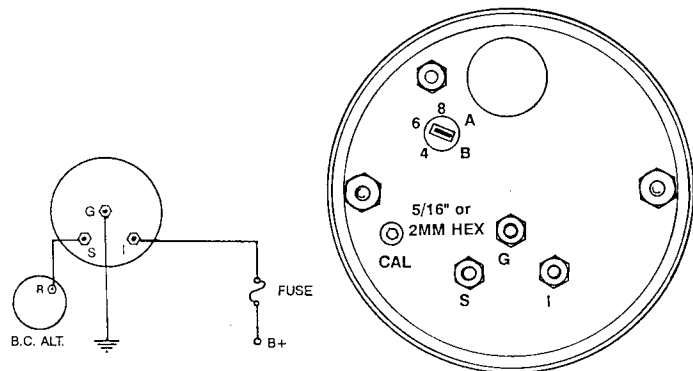
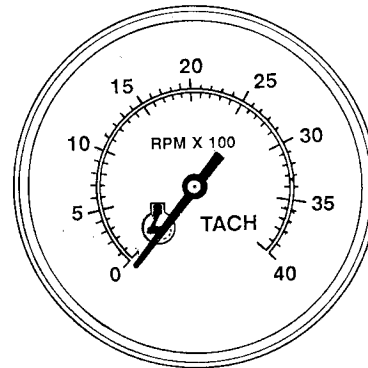

# CONTROLLER

## CONTROL/STATUS INDICATOR PANEL

Generator set operational mode selector switch, audible alarm and 16 visual indicators of system condition are contained on the Indicator panel.

Programmed decisions of starting and stopping as well as monitoring the system conditions and channeling the appropriate actions is performed by the Decision Maker Microprocessor control board.

The Indicator panel is powered by a 12vdc regulated supply from the Processor circuit board. Interconnection between the two circuit boards is by a ribbon connector.

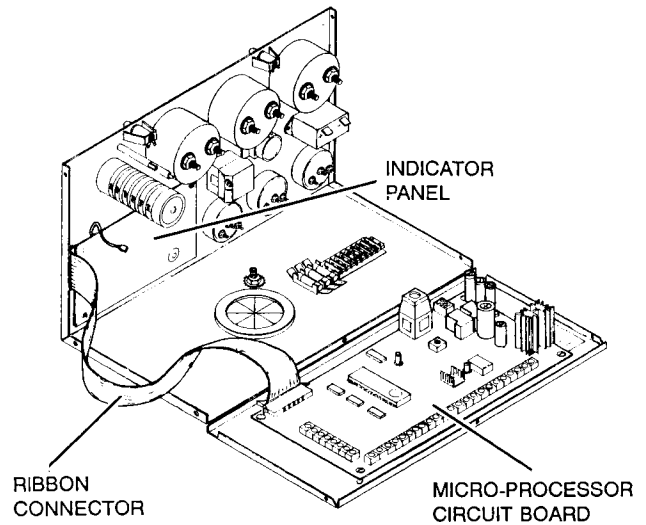
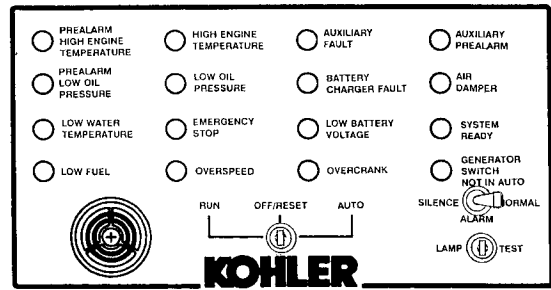

- **RUN-OFF/RESET-AUTO SW.** Selects the mode of Engine operation.

- **RUN** - Start and run the generator set locally
- **OFF/RESET** - Stop the generator set locally, and reset the system after a fault shutdown.
- **AUTO** - Allows Start/Stop commands from a remote location.

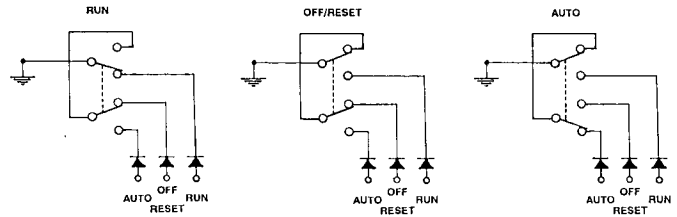

- **LAMP TEST SW.** Provides a ground to all 16 LED indicator input circuits. All indicators should light.

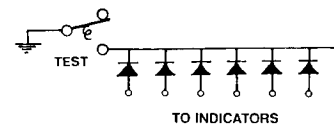

- **ALARM HORN.** Provides an audible signal indicating a fault is or was on the system or the main control switch is not in the "Auto" position.

- **ALARM SILENCE SW.** Allows the Horn to be silenced when the Engine control switch is in the "Auto" position. Horn can not be silenced in the "Run" or "Off/Reset" positions

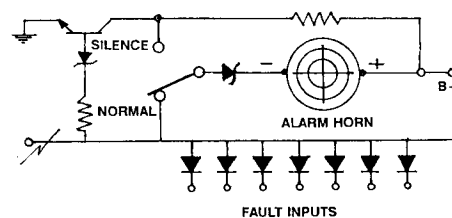

# CONTROLLER

## CONTROL/STATUS INDICATOR PANEL CIRCUIT BOARD

\* Will light corresponding indicator when terminal is grounded.

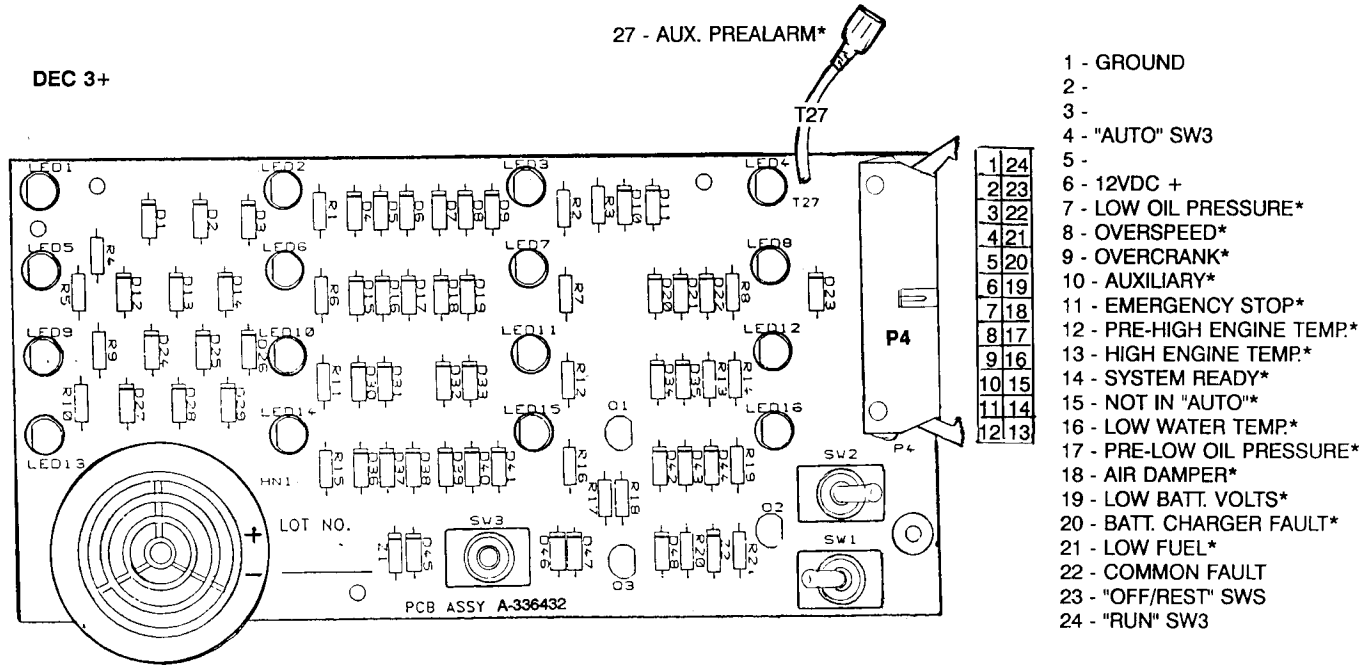
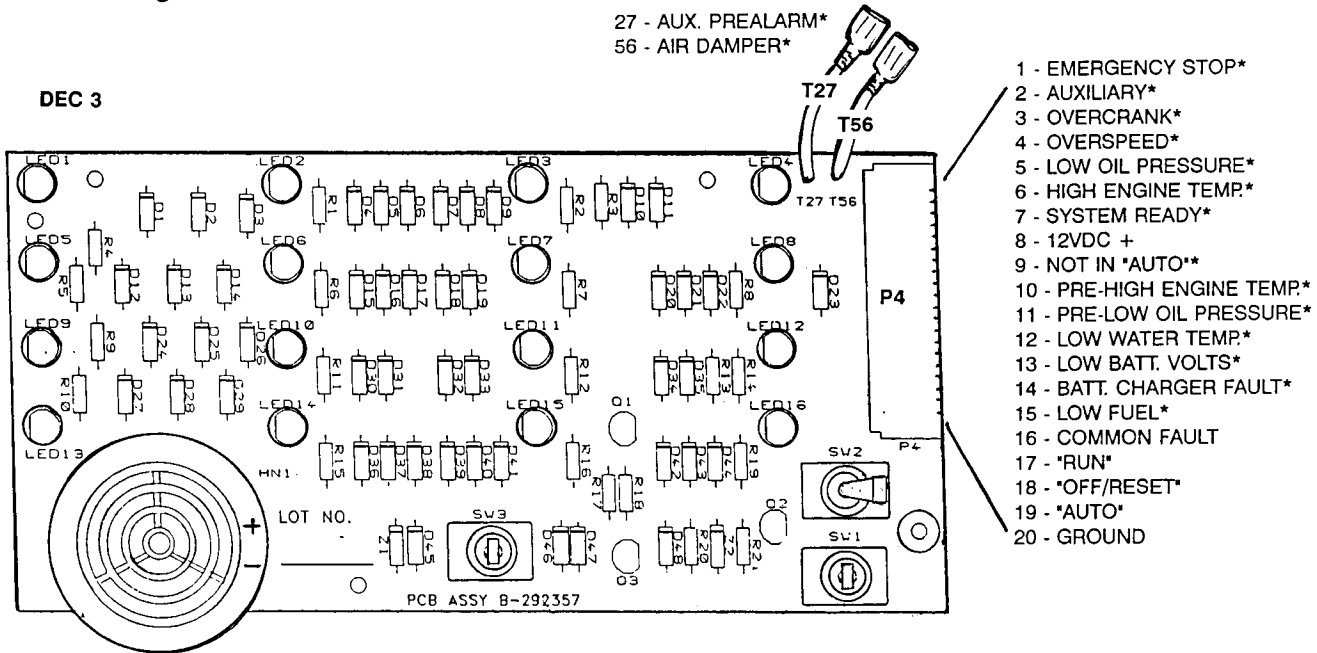



# CONTROLLER

## CONTROL/STATUS INDICATORS

A total of 16 LED indicators are provided, 1 Green (System Ready) 3 Amber (Prealarm) and 12 Red. Not all 16 input senders are standard or factory wired.

## FRII STANDARD FEATURES

- SYSTEM READY
- HIGH ENG. TEMP.
- OVERCRANK
- LOW COOLANT LEVEL (AUX)
- EMERGENCY STOP (DDC only)
- SW. NOT IN AUTO
- LOW OIL PRESS
- OVERSPEED

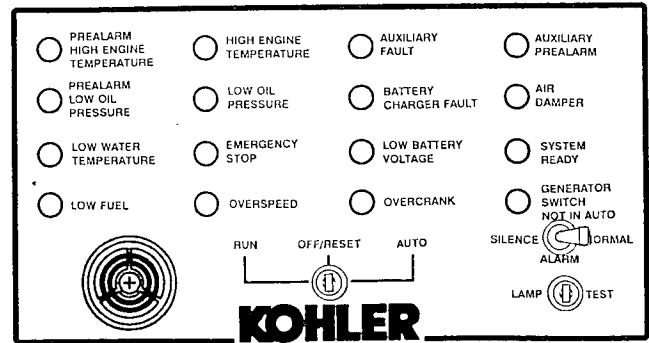

**SYSTEM READY.** Indicator lights when the Start/Selector switch is in the "AUTO" position and the system senses no faults. The set is ready to start on a remote command.

**GENERATOR SWITCH NOT IN AUTO.** Lamp lights and alarm sounds when Start/Selector switch is in RUN or OFF/RESET position indicating the set cannot be operated automatically from a remote location.

### HIGH ENGINE TEMP.

**LOW OIL PRESS.** - Switches are factory installed and will close when coolant temperature reaches approximately 225°F (107°C) and Oil Pressure drops to approximately 5.5 - 10.5 psi (38-72kPa). After 5 seconds from switch closure the corresponding Indicator will light the horn will sound and engine shutdown will occur.

**LOW WATER TEMPERATURE.** - Optional Switch is required to be installed in engine block. Contacts will close to activate indicator and horn at 60°F (16°C) and open at 80°F (27°C). Usually used in conjunction with block heaters and is included with the Prealarm Senders Kit. Wiring is standard and located in the harness.

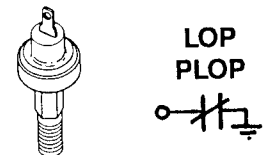
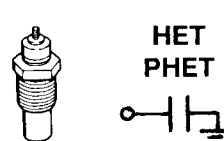
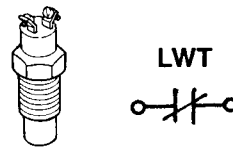

### PREALARM HIGH ENG. TEMP.

**PREALARM LOW OIL PRESS.** - Optional switches are required to be installed in the engine block which will activate the indicators and horn at temperatures slightly below and pressures slightly above the standard cutout switch ratings. No engine shutdown will occur. Wiring is standard and located in the harness. Dual temperature switches may be installed.

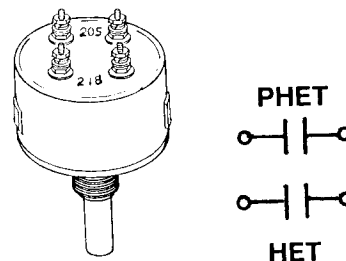

# CONTROLLER

## CONTROL/STATUS INDICATOR PANEL

**LOW FUEL.** - Requires customer wiring and tank mounted switch to close at desired fuel level. Will activate indicator and horn.

**EMERGENCY STOP.** - Requires switch in control panel or optional N.C. remote switches. Contact opening provides Lamp indication, Horn alarm and an immediate engine shutdown.

**BATTERY CHARGER FAULT.** - Relay in charger required to provide contact closure on charger malfunction. Ground Signal will light indicator if charger malfunctions. (optional)

**LOW BATTERY VOLTAGE.** - Indicator will light if battery voltage drops below a preset level. Requires ground signal from battery charger relay contact closure. (optional)

**OVERCRANK.**- Cranking stops and Indicator will light if engine does not start after 45 seconds of continuous cranking, 75 seconds of cyclic cranking or 15 seconds of locked rotor.

- OVERCRANK LAMP WILL FLASH IF: Speed sensor signal to microprocessor is absent longer than one second.

**OVERSPEED.** - Indicator will light, horn will sound and engine will shut down if governed frequency exceeds 70 Hz. The signal is provided to the microprocessor by the Speed Sensor pickup.

**AIR DAMPER.** Lamp lights after emergency stop, overspeed or overvoltage fault. Indicator signifies the engine air damper is closed. Lamp remains lit until air damper is manually reset. (activated by closure of microswitch contacts, lead T56 to ground.)

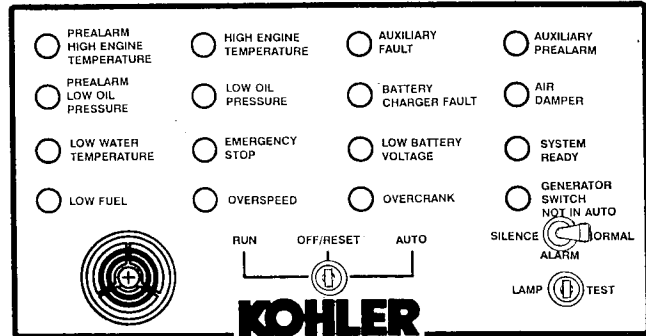

**AUXILIARY PREALARM.** Flashing Amber indicator. Activated by customer provided sensing devices. Pre-low fuel, Generator overload etc. (lead T27 to ground will activate.)

**AUXILIARY FAULT.** - This lamp provides numerous indications:

- LAMP WILL LIGHT, HORN WILL SOUND AND ENGINE WILL SHUT DOWN IF:  
 - **Overvoltage condition occurs.**  
 Activated by optional Overvoltage circuit board (lead 30). on Dec 3 controllers

- LAMP WILL LIGHT, HORN WILL SOUND AND ENGINE WILL SHUT DOWN 5 SECONDS AFTER:  
 - **Low Coolant level** (standard).  
 - **High oil temperature** (optional).  
 Feature is inhibited during first 30 seconds after startup.

- LAMP WILL LIGHT AND HORN WILL SOUND IF:  
 - **Optional Emergency Stop switch is reset with the Engine Start selector switch in the AUTO or RUN position.**

- LAMP WILL FLASH AND HORN WILL SOUND IF:  
 - **No AC output is available** (after 10 seconds of start-up).  
 - **Battery is connected with the Engine Start selector switch in the RUN or AUTO position.**  
 - **Low battery voltage** or hardware reset of the Microprocessor occurs.

# INDICATOR/FAULT SENDERS DEC 3+

# CONTROLLER

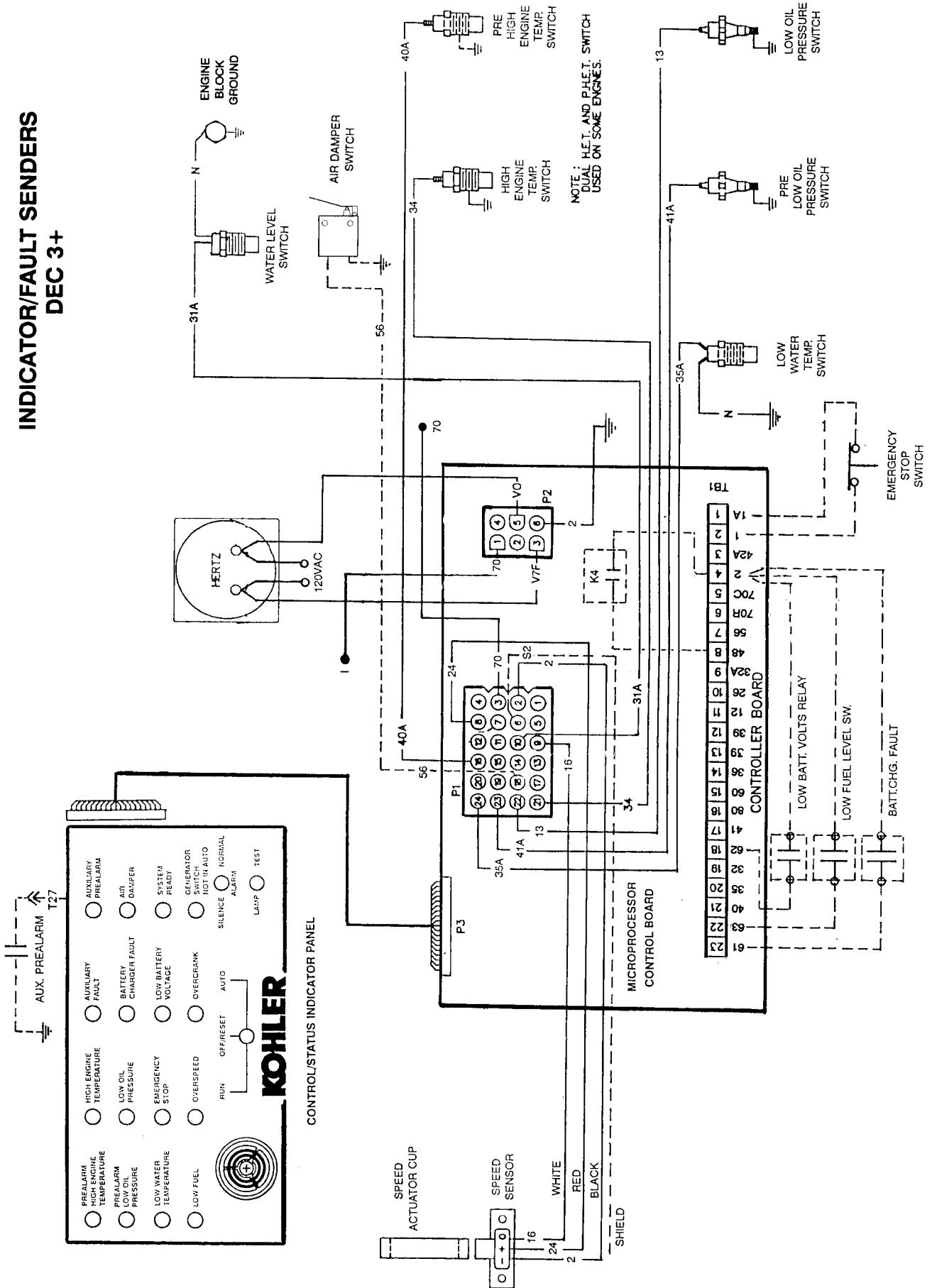

# INDICATOR/FAULT SENDERS DEC 3

# CONTROLLER

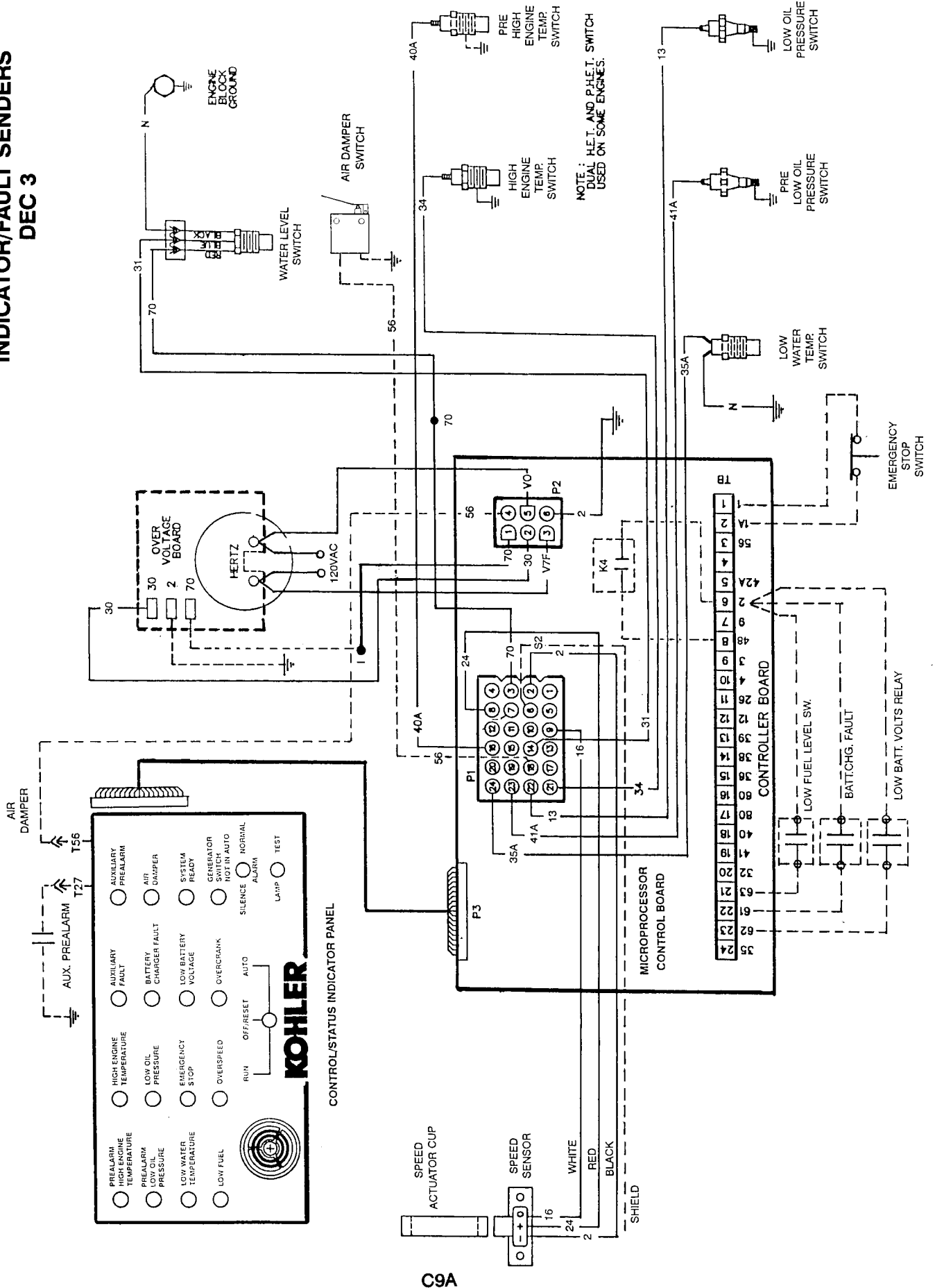

# CONTROLLER

## COOLANT LEVEL DETECTOR (LWL)

The Liquid sensor is located in the upper radiator tank and detects the presence and absence of liquid at the probe tip.

The device will provide a (-) signal via lead 31 to the microprocessor board to initiate an engine shut-down, sound the alarm and light the AUXILIARY lamp. The shut-down is delayed for 5 seconds and the circuit is inhibited for 30 seconds on engine start-up.

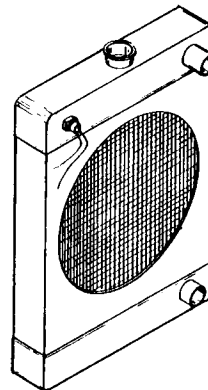

## TYPE A (DEC 3)

Both 12 and 24v senders are available. The voltage rating is stamped in the hex housing and must match the system voltage. A bias voltage must be available for the 3 wire device to operate.

During operation with liquid present at the probe an open circuit exists between the Blue (output) and Black (ground) leads.

When liquid is absent from the probe the output terminal will go to ground potential.

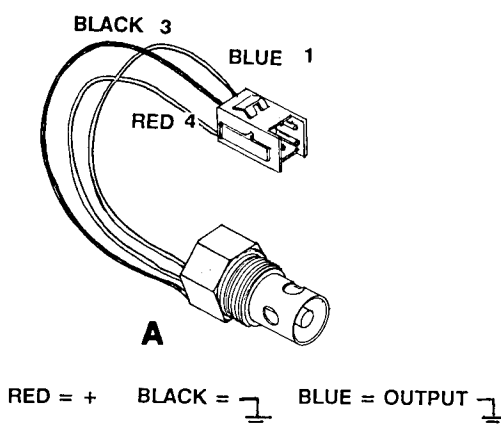

## TYPE B (DEC 3+)

The sensor used for both 12 & 24 volt systems with DEC 3+ controls is a 2 wire 12v device.

Voltage at the sensor terminals during normal operating conditions when emersed in coolant is 12.5 vdc.

The resistance value of the device will decrease when coolant is removed from the probe. The decrease in resistance will cause the voltage to drop to approximately 7 volts initiating an engine shut-down.

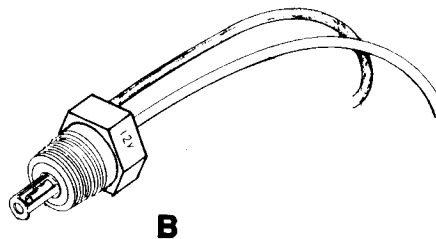



# CONTROLLER

## SPEED SENSOR (Proximity Sensor)

The Speed Sensor provides the Microcomputer circuit board with digital information on the rotating status of the generator set.

The device when energized will provide an output signal when a ferrous metal comes in proximity to its sensing surface.

Input voltage to the sensor is approximately 9.5vdc. During engine cranking and running an average of approximately 7vdc will appear at the output.

The Sensor is located on the end bracket and mounted so an air gap of .020" is between the sensor and actuator. Two signals are provided per revolution of the rotor shaft.

The microcomputer will monitor and respond to the sensors output signals.

- The signal pattern produced at an engine speed of 750 RPM (25Hz) will be interpreted as engine run speed and the cranking cycle will be terminated.

- If the engine run signal provided at 750RPM is not available after a cyclic engine crank totaling 75 seconds or after 45 seconds of continuous cranking, the start attempt will be aborted and the Overcrank indicator will light.

- If no signal is received after 5 seconds of cranking the controller will assume the engine is not rotating and a locked rotor condition exists. After a 5 second rest another 5 second start attempt will be made. If no signal is received within this 15 second interval the cranking cycle will terminate and the Overcrank indicator will light.

- The signal produced at 2100 RPM (70Hz) and above will initiate an Overspeed shutdown.

- If during operation a signal is absent for longer than 1 second and AC generated voltage is available the generator set will continue to run, however the Overcrank indicator will flash indicating a fault has occurred in the sensor circuit and service is required prior to the next start-up.

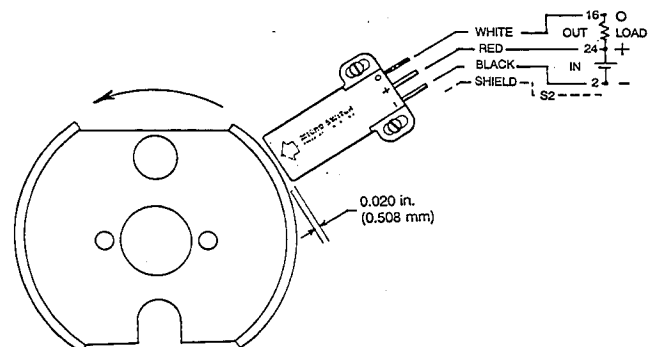
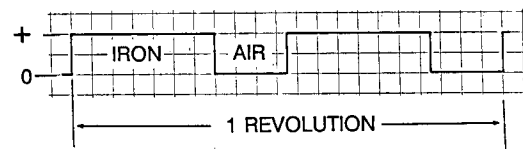
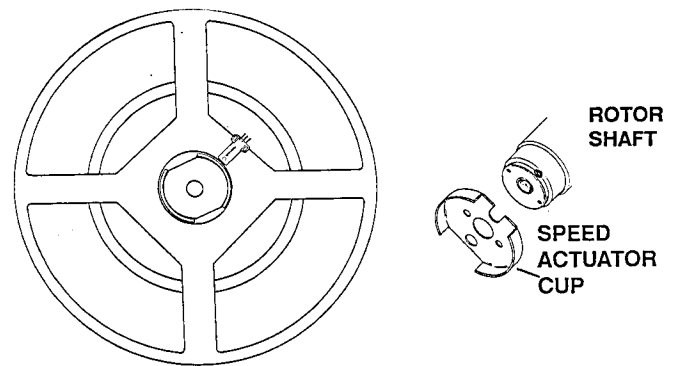
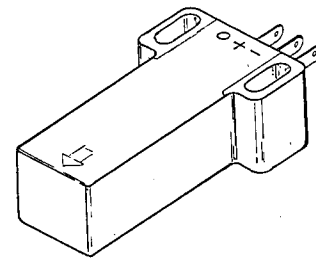

# CONTROLLER

## SPEED SENSOR (Proximity Sensor)

The sensor requires a shielded interconnection cable to the micro-processor circuit board. The shield (S2) is grounded through terminal 6 of the P1 connector.

The device can be bench checked by applying 12VDC to the input and observing a DC output when the circuit is triggered by placing a flat piece of iron or steel at the sensing surface.

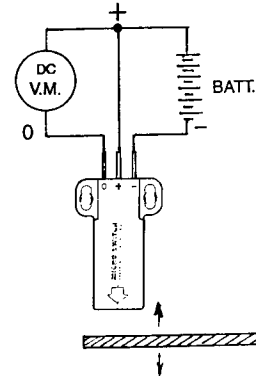
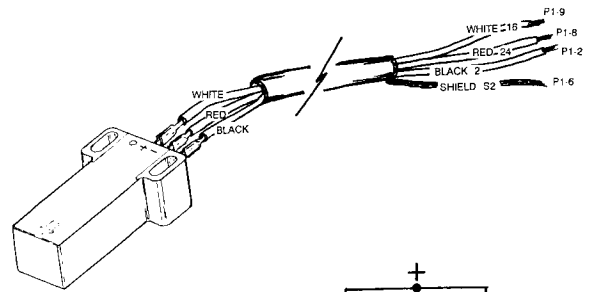



# CONTROLLER

## DEC 3 MICROPROCESSOR CIRCUIT BOARD

The main control circuit board is designed around a self contained, single-chip digital microcomputer that has memory, logic, data bus, control bus and I/O ports in one 40-pin integrated circuit.

The control algorithm is provided in ROM (Read-Only-Memory), which maintains data storage without a power supply, ensuring that programmed information is never lost.

Hardware and software filters protect the board from electrical noises common to generator set applications.

Operating range is from - 40 to 185° F.  
(- 40 to 85° C )

The G-292806 Board illustrated will control both 12 and 24 volt engine starting systems.

Input and output signals are provided at the three P connectors ( P1, P2, P3 ) and TB1 terminal strip.

The P3 connector provides the interconnection for the 20 conductor ribbon harness and the Control/Status Indicator panel.

The TB1 barrier strip allows interconnection of options such as: remote operation, annunciators, emergency stop switches, and dry contact kits.

The P1 and P2 connectors provide input and output connections between the engine, generator and controller.

Three sealed relays K2, K3, and K4 provide the engine starting , running and stopping control. LED's are connected across the relay coils to indicate voltage has been directed to energize the relay.

The K2 relay controls the battery supply to the starter solenoid on an engine crank command. The output circuit is protected by the F3 fuse.

The K3 relay provides battery voltage to the engine run circuit, (Fuel pump/solenoid, Ignition etc.) the meter cabinet components and voltage regulator. The contact circuit is also protected by the F3 Fuse.

The K4 relay supplies the control logic circuits with a 12vdc regulated supply. It also functions as the emergency stop relay.

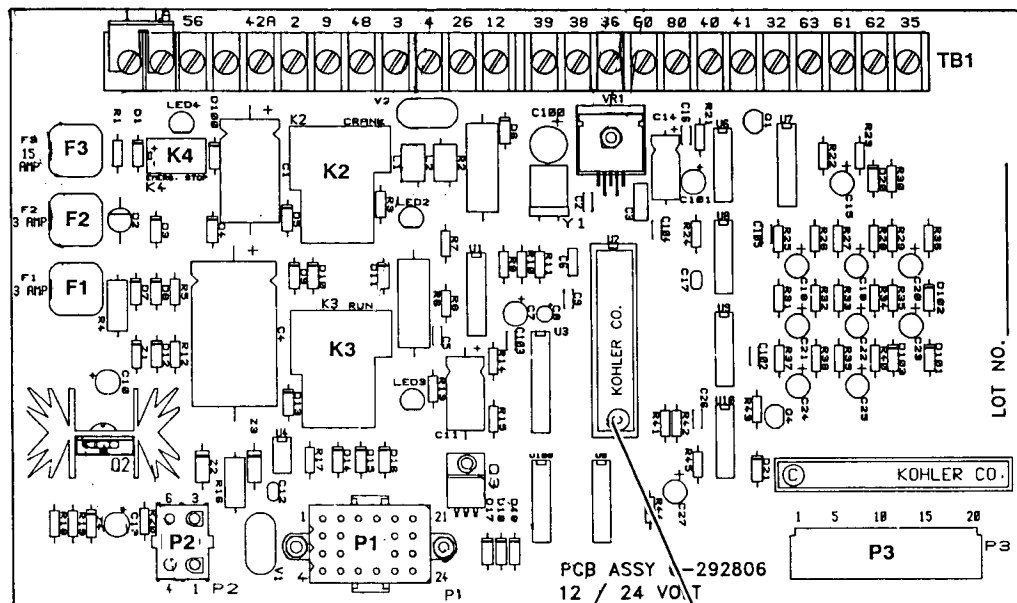

MICROCOMPUTER

# CONTROLLER

## TB1 TERMINAL STRIP - DEC 3

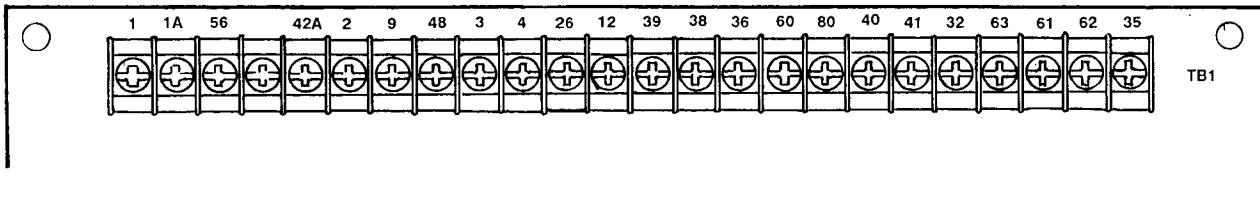

The 24 terminal barrier strip is provided on the Main Control board for connecting of optional features.

It is recommended that stranded wire or the optional connection kit be used if multiple connections are made to the terminal strip. Lowering and raising the rear hinged panel when solid conductors are used imposes stress on the circuit board.

### - ( 3 - 4 ) REMOTE START STOP

When the status panel operational selector switch is placed in the "AUTO" position the generator set can be remotely started and stopped by a switch or a dry set of contacts connected across terminals 3 - 4.

**Do not apply an external voltage.**

Open circuit voltage across 3(-) and 4(+) is 12vdc. The circuit draws approximately 42 ma when completed.

Two 14 ga. conductors are recommended up to runs of 2000 ft. The conductors should be run in a conduit separate from the conduits used for generator load cables or battery charging cables to prevent radiated or induced signals to the circuit board.

When the circuit is opened after operating from a remote start the generator set will continue to run for an additional 5 minutes to allow for an Engine Cooldown.

### - ( 1 - 1A ) EMERGENCY STOP

A circuit must be completed between 1 and 1A for the generator set to operate.

A panel mounted "EMERGENCY STOP" switch, or optional "Break Glass" switch provides a maintained set of normally closed contacts. If this circuit is opened during operation an immediate shut down will occur.

A restart can not be made until both the emergency stop switch and Main operational control switches are "RESET".

If an emergency stop switch is not installed a jumper is required across the terminals.

### - ( 9 - 2 ) CRANK MODE

Cyclic engine cranking of 15 sec. crank with 15 sec. rest for a total of 75 seconds is standard. The cyclic feature can be eliminated by placing a jumper between terminals 9 and 2. This will allow a continuous engine crank of 45 seconds on a start attempt prior to an "overcrank" termination.

### - ( 42 - 2 ) VOLTAGE SUPPLY

Terminals 42A (+) and 2 (-) provide a 3 amp fused (F1) systems battery voltage supply for accessories or optional devices. (12 or 24vdc)

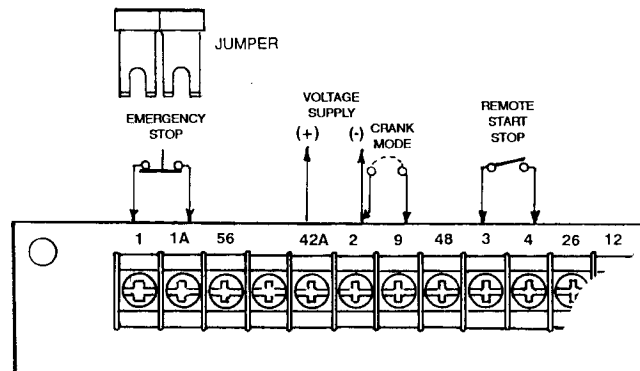

# CONTROLLER

## TB1 TERMINAL STRIP - DEC 3

The following terminals are output only and allow for connection of optional remote indicators or inputs to dry contact kits. The terminals provide a ground (-) output when the fault is activated and limited to 100 milliampere loads.

- (48) EMERGENCY STOP - E.S.
- (56) AIR DAMPER - A.D.
- (26) AUXILIARY - AUX.
- (12) OVERCRANK - O.C.
- (39) OVERSPEED - O.S.
- (38) LOW OIL PRESSURE - L.O.P.
- (36) HIGH ENG. TEMP. - H.E.T.
- (60) SYSTEM READY - S.R.
- (80) SW. NOT IN 'AUTO' - N.I.A.
- (40) PRE-HIGH ENG. TEMP. - P.H.E.T.
- (41) PRE-LOW OIL PRESSURE - P.L.O.P.
- (35) LOW WATER TEMP. - L.W.T.
- (32) COMMON FAULT - C.F.

The Common Fault terminal 32 will be at ground (-) potential when any of the 10 following faults occur:

- HIGH ENG. TEMP. - PRE-HIGH ENG. TEMP
- LOW OIL PRESS. - PRE-LOW OIL PRESS.
- LOW WATER TEMP. - OVERCRANK
- OVERSPEED - AUXILIARY
- LOW FUEL - AIR DAMPER.

It is used as the input signal for the optional Audio-Visual Alarm.

The **Common Fault Relay Kit** can be used if a customer desires less or custom combinations of any of the above.

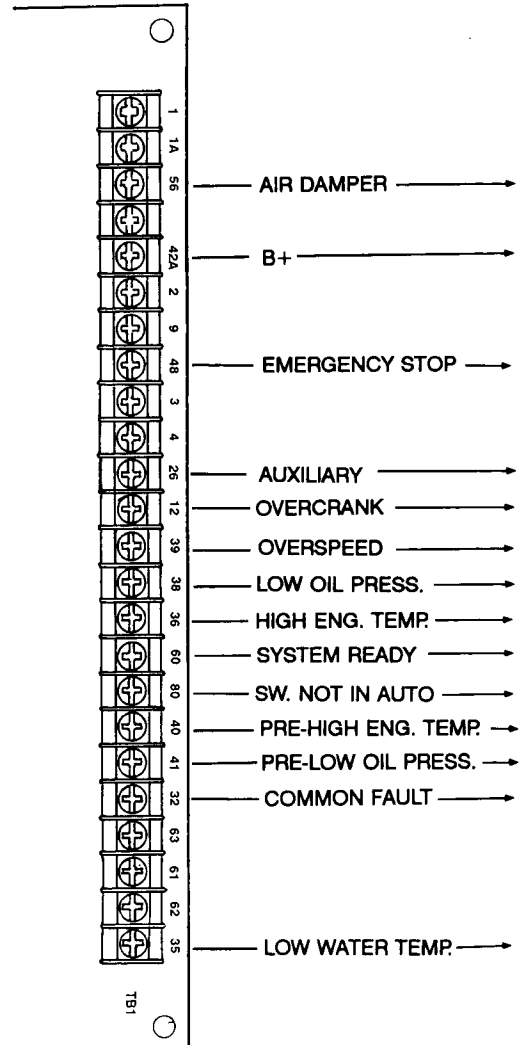

# CONTROLLER

## TB1 TERMINAL STRIP

Terminals 61, 62 and 63 can be used as terminating points for both input and output signals of optional Battery Charger Fault (61), Low Battery Charger Voltage (62) and Low Fuel Level (63).

A negative (-) signal will energize the Status Panel indicator as well as optional remote annunciator indicators connected to the terminal. (Terminal 42A is positive (+), terminal 2 is negative (-).

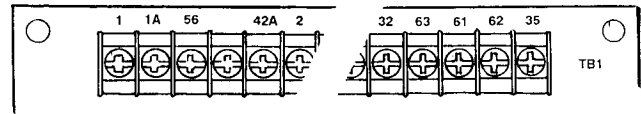

### - (61) BATTERY CHARGER FAULT

Terminal 61 can be connected to a relay contact located in the charger which is activated when a fault occurs with the battery charger. (No AC input or DC output) Closure of the contact will energize the Battery Charger Fault indicator(s).

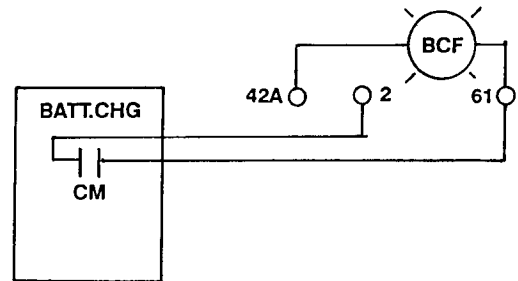

### - (62) LOW BATTERY VOLTAGE

Terminal 62 can be connected to a relay contact located in the battery charger which is activated when the battery voltage drops below a preset level for longer than 2 seconds. The relay will reset removing the signal if the voltage rises to a preset level above the alarm trip point. The Low Battery Voltage indicator(s) will light on contact closure.

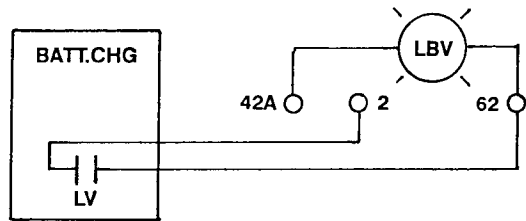

### - (63) LOW FUEL LEVEL

Terminal 63 allows for connection of a fuel level switch and indicator. Contacts of the switch provide a (-) signal to light the indicator(s) and sound the alarm(s) when the fuel level drops below a preset level.

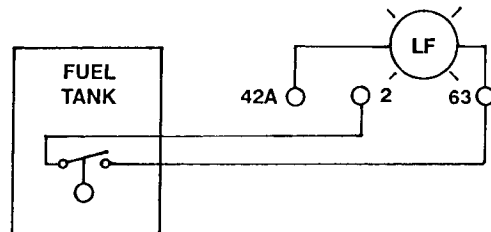

# CONTROLLER

## CONNECTORS: P1 P2 P3 (DEC 3)

The majority of engine/generator condition inputs and engine control outputs are provided from the harness connector P1.

AC input for voltage sensing and optional overvoltage shutdown signal as well as DC output to the instrument panel engine gauges and illumination lamps is provided by the P2 plug connector.

The signal for the 'AIR DAMPER' indicator on the Status Panel is also supplied from the P2 connector.

The P3 20 terminal plug provides interconnection to the Status Panel switches and indicators via a ribbon harness. Fault signals to the P3 are common to the TB1 terminals.

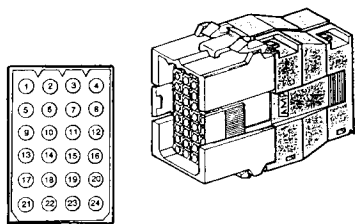
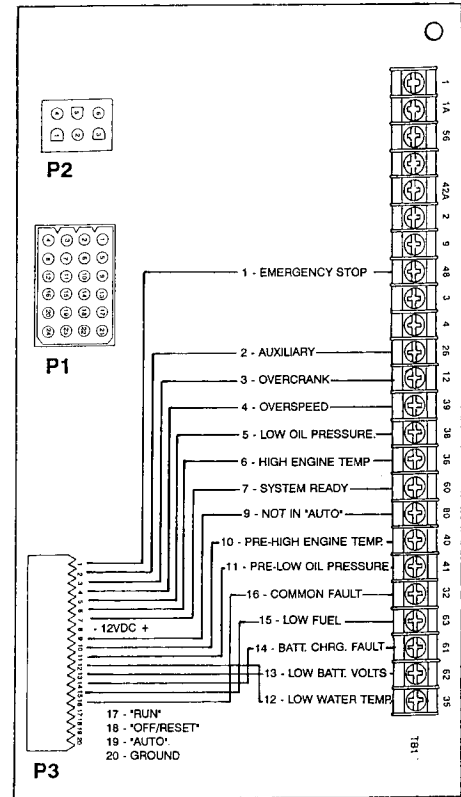

## P1 CONNECTOR

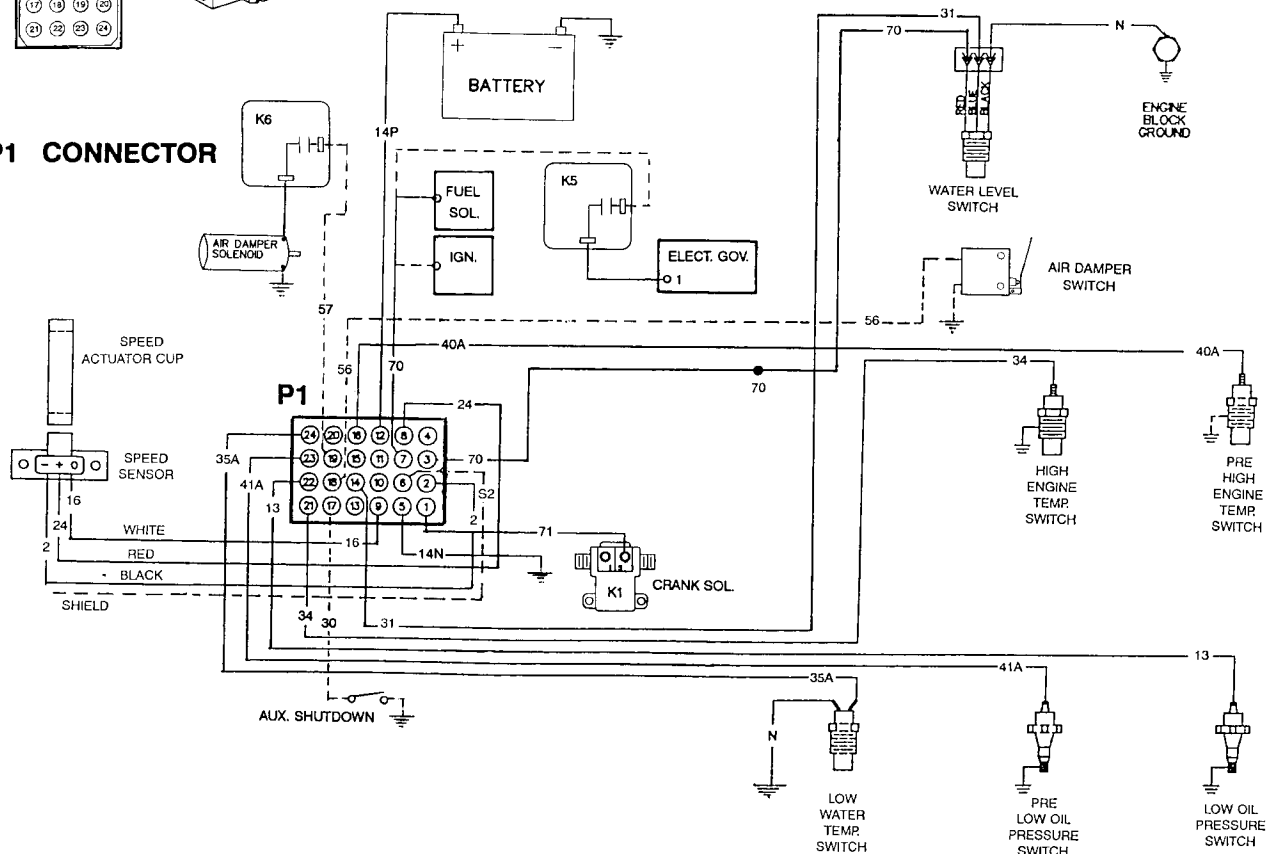

# CONTROLLER

## P2 CONNECTOR

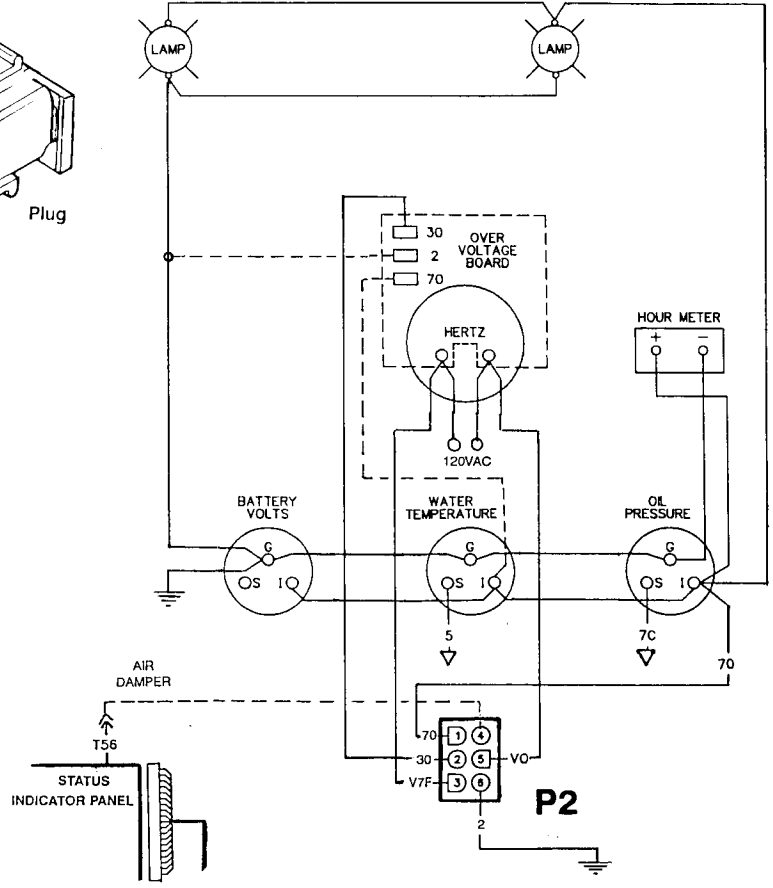
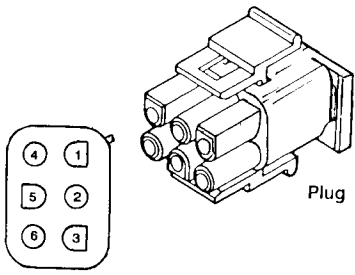

## P3 CONNECTOR

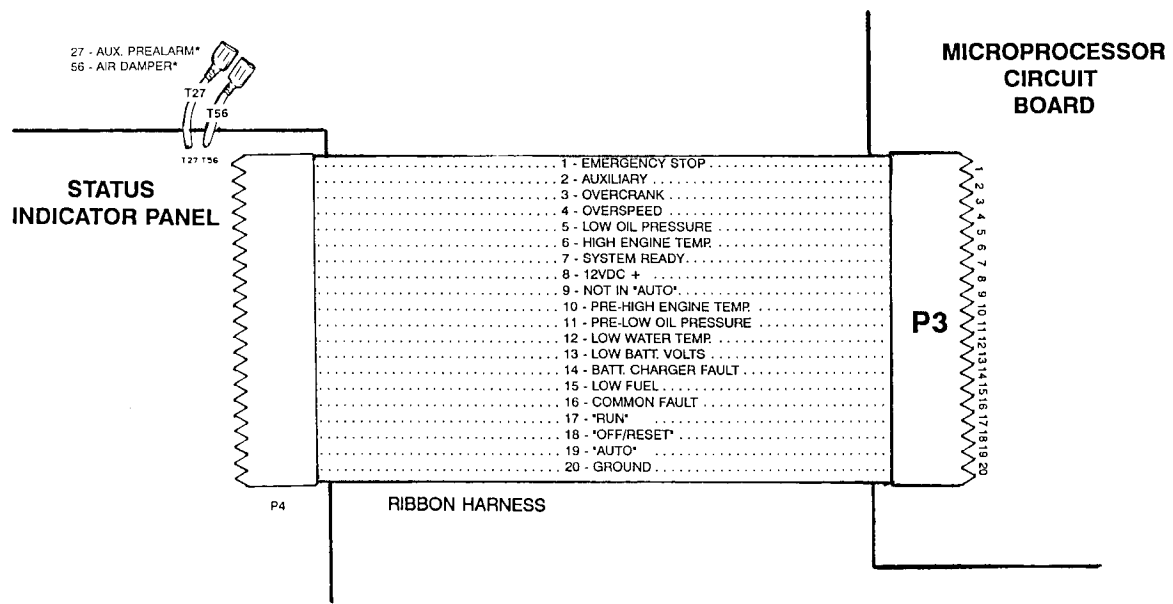

# CONTROLLER

## FUSES; F1 - F2 - F3 (DEC 3)

The three fuses are located in holders soldered to the microprocessor circuit board and protect the wiring and circuit foil from damage in the event of excessive fault currents.

The F1 fuse provides overcurrent protection from accessories or options powered from terminal 42A on the TB1 terminal strip. The 3 Amp fuse is rated at 250 volts.

The F2 fuse protects the circuits powering the main logic and relay coils on the microcomputer board as well as the Status/Indicator panel. It is also a 3 Amp, 250 volt fuse.

The F3 fuse provides circuit protection if faults occur on engine electrical components powered through the K2 and K3 relay contacts. The ceramic fuse is rated at 15 amps/ 250v.

## RELAYS; K2 - K3 - K4 (LED'S 2,3,4)

The (3) 12vdc sealed relays soldered to the circuit board provide controlled output power to the generator sets DC electrical components: Start solenoid, Fuel valves, Governor control, Fuel pump, Ignition, Voltage regulator, Solenoids, Slave relays etc. Red LED's are connected across the relay coils to indicate when voltage is applied to the coils.

The K2 relay provides the cranking control to the engine starter crank solenoid (K1). When an engine start command is initiated the logic circuit will cyclicly energize the relay coil, 15 seconds on and 15 seconds off for a total time of 75 seconds. This cyclic mode can be changed to 75 seconds of continuous energizing by placing a jumper between terminals 2 and 9 of the TB1 terminal strip.

The K3 relay provides battery voltage supply (12 or 24vdc) to the engine, generator and controller components required for normal "run" operation. It remains energized during a start/run command and is deenergized 5 minutes after a remote stop command or immediately on an emergency stop signal.

A normally open set of K4 contacts are in series with both the K2 and K3 relay coils. The K4 relay (emergency stop), must be energized before an engine crank and run can occur. If the circuit to the K4 coil is disrupted both the K2 and K3 relays will be deenergized. The emergency stop switch when used is connected in series with the K4 relay coil. (TB1 terminals 1 - 1A)

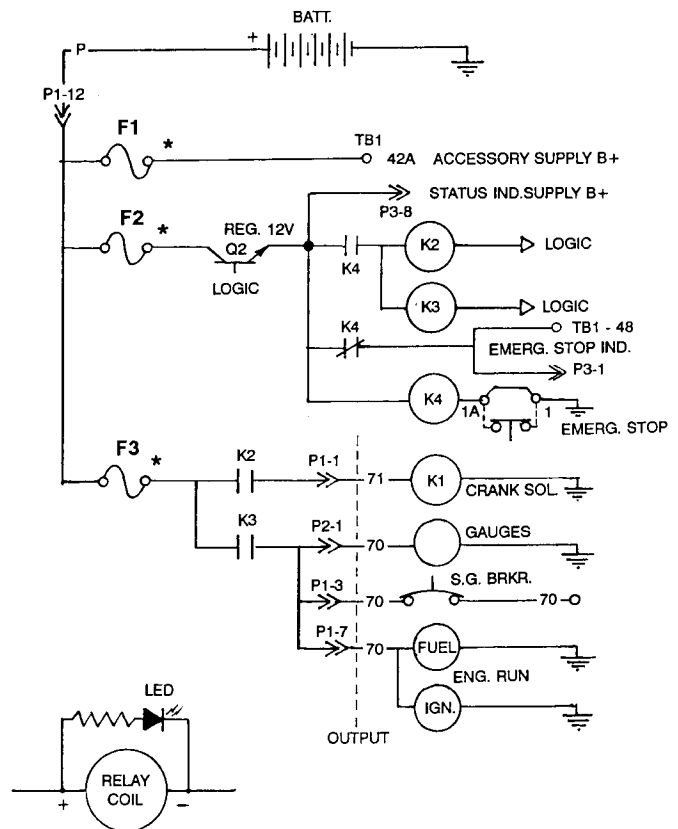
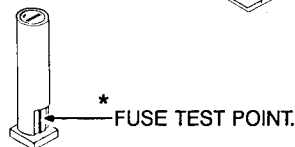
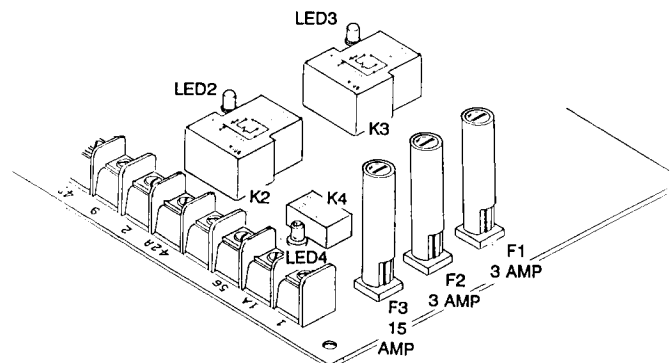





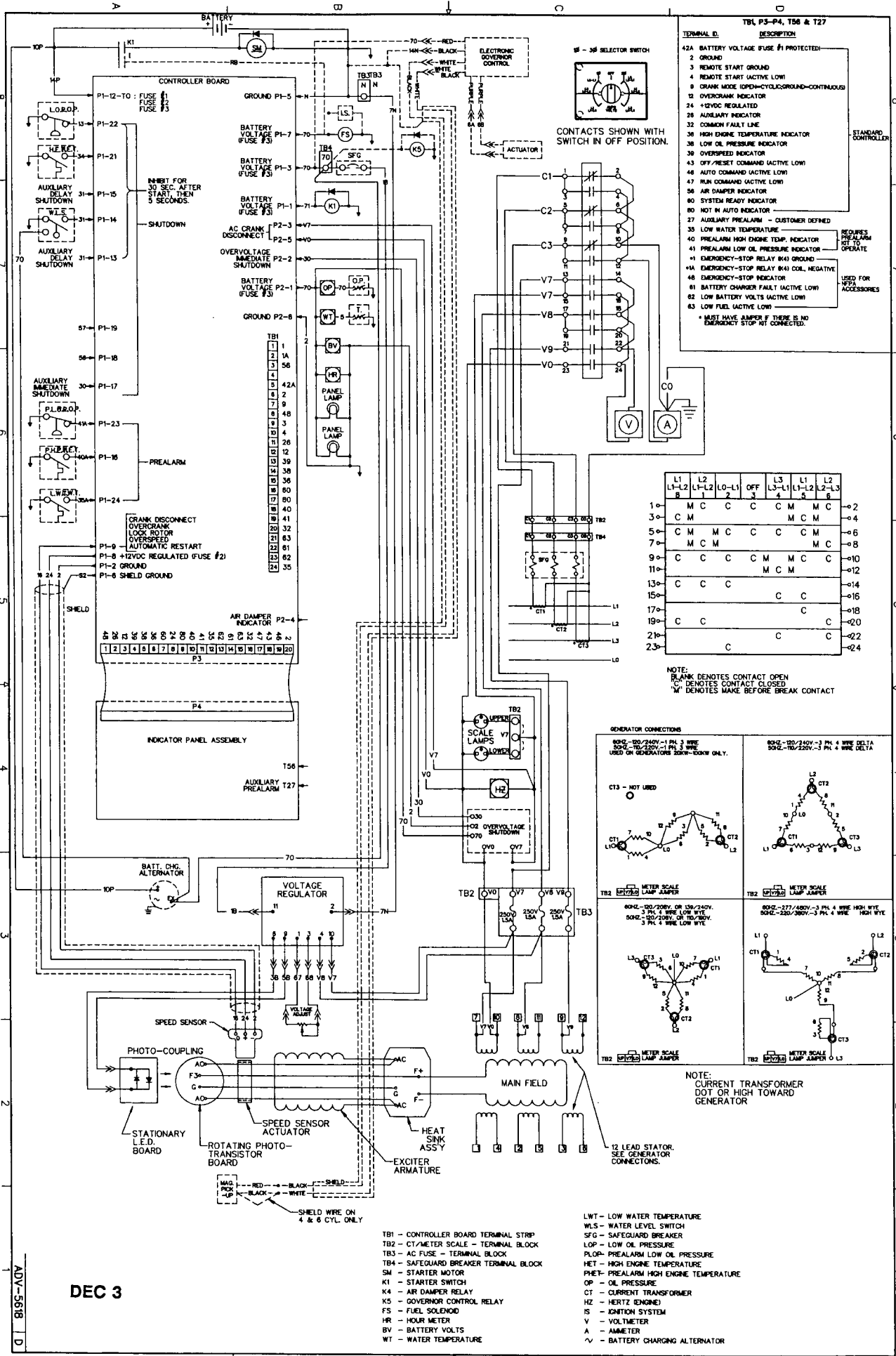

**TERMINAL BLOCK DESCRIPTION**

TERMINAL	DESCRIPTION
42A	BATTERY VOLTAGE (FUSE #1 PROTECTED)
2	GROUND
3	REMOTE START GROUND
4	REMOTE START (ACTIVE LOW)
9	CRANK MODE (OPDM-CYCLOGROUND-CONTINUOUS)
12	OVERCRANK INDICATOR
24	+12VDC REGULATED
26	AUXILIARY INDICATOR
32	COMMON FAULT LINE
36	HIGH ENGINE TEMPERATURE INDICATOR
38	LOW OIL PRESSURE INDICATOR
39	OVERSPEED INDICATOR
43	OFF/RESET COMMAND (ACTIVE LOW)
48	AUTO COMMAND (ACTIVE LOW)
47	RUN COMMAND (ACTIVE LOW)
56	AIR DAMPER INDICATOR
80	SYSTEM READY INDICATOR
80	NOT IN AUTO INDICATOR
27	AUXILIARY PREALARM - CUSTOMER DEFINED
35	LOW WATER TEMPERATURE
40	PREALARM HIGH ENGINE TEMP. INDICATOR
41	PREALARM LOW OIL PRESSURE INDICATOR
+1	EMERGENCY-STOP RELAY (W4) GROUND
+1A	EMERGENCY-STOP RELAY (W4) OIL, NEGATIVE
48	EMERGENCY-STOP INDICATOR
61	BATTERY CHARGER FAULT (ACTIVE LOW)
62	LOW BATTERY VOLTS (ACTIVE LOW)
83	LOW FUEL (ACTIVE LOW)

\* MUST HAVE AMPER F THERE IS NO EMERGENCY STOP KIT CONNECTED

L1	L2	L3	OFF	L1	L2	L3
L1-L2	L1-L2	L0-L1	2	L3-L1	L1-L2	L2-L3
1	2	3	4	5	6	7
1-0	M	C	C	C	M	C
3-0	C	M			M	C
5-0	C	M	C	C	C	M
7-0	M	C	M			C
9-0	C	C	C	C	M	C
11-0	C	C	C		M	C
13-0	C	C	C			
15-0				C	C	
17-0						C
19-0	C	C				C
21-0				C		C
23-0				C		

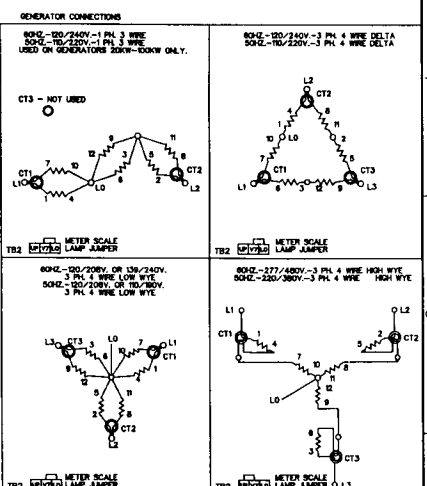

DEC 3

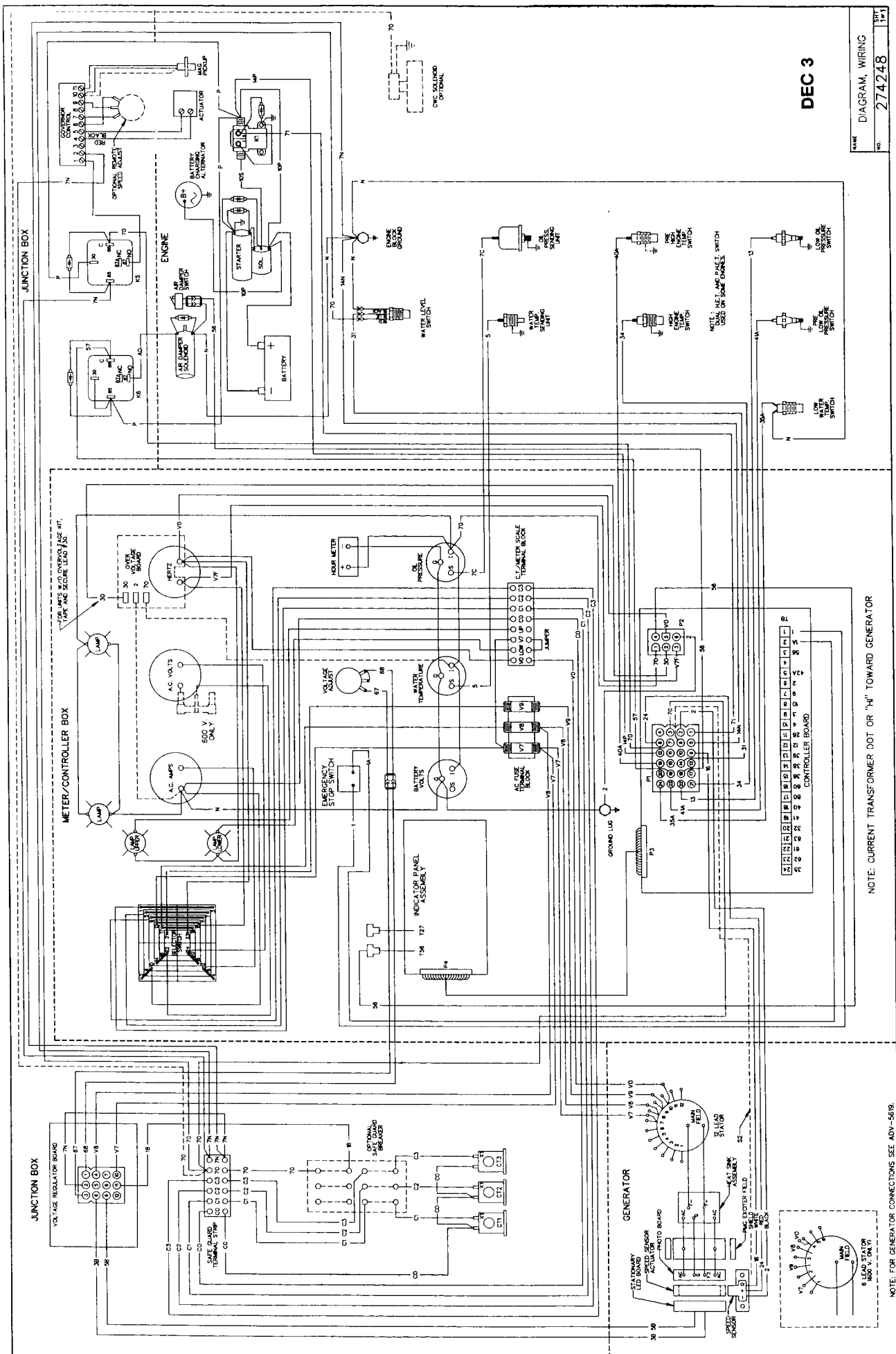

DEC 3

NOTE: CURRENT TRANSFORMER DOT OR "H" TOWARD GENERATOR

NOTE: FOR GENERATOR CONNECTIONS SEE ADV-5819.

# CONTROLLER

## DEC 3+ MICROPROCESSOR BOARD

The Dec 3 Plus Controller utilizes the Kohler 336415 circuit board. It was introduced in 1995 and is the standard microprocessor circuit board on FR generators with serial numbers above 363369.

The main control circuit board is an enhanced version of the Dec 3 design.

The board will control both 12 and 24 volt engine starting systems. It features adjustable generator Overvoltage shutdown protection and a Prime Power Mode.

The Prime power feature allows disabling the LED indicators and alarm horn when in the 'OFF' mode to reduce battery drain.

Input and output signals are provided at the three P connectors ( P1, P2, P3 ) and TB1 and TB2 terminal strips.

The P3 connector provides the interconnection for the ribbon harness and the Control/Status Indicator panel.

The TB1 and TB2 barrier strips allow interconnection of options such as: remote operation, annunciators, emergency stop switches and dry contact kits.

The P1 and P2 connectors provide input and output connections between the engine, generator and controller.

Three sealed relays K2, K3, and K4 provide the engine starting , running and stopping control. LED's are connected across the relay coils to indicate voltage has been directed to energize the relay.

The K2 relay controls the battery supply to the starter solenoid on an engine crank command. The output circuit is protected by the F3 fuse.

The K3 relay provides battery voltage to the engine run circuit, (Fuel pump/solenoid, Ignition etc.) the meter cabinet components and voltage regulator. The contact circuit is also protected by the F3 Fuse.

The K4 relay supplies the control logic circuits with a 12vdc regulated supply. It also functions as the emergency stop relay.

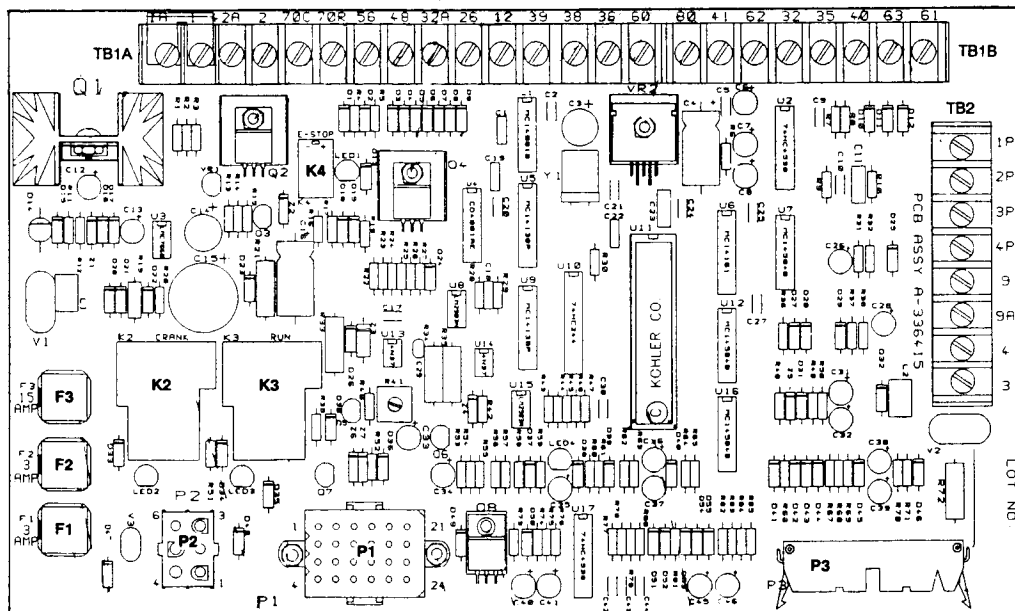

# CONTROLLER

## TB1 TERMINAL STRIP - DEC 3+

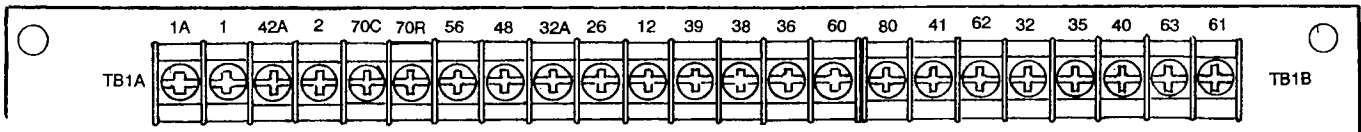

The 23 terminal barrier strip is provided on the Main Control board for connecting of optional features.

It is recommended that stranded wire or the optional connection kit be used if multiple connections are made to the terminal strip. Lowering and raising the rear hinged panel when solid conductors are used imposes stress on the circuit board.

### - ( 1 - 1A ) EMERGENCY STOP

A circuit must be completed between 1 and 1A for the generator set to operate.

A panel mounted "EMERGENCY STOP" switch, or optional "Break Glass" switch provides a maintained set of normally closed contacts. If this circuit is opened during operation an immediate shut down will occur.

A restart can not be made until both the emergency stop switch and Main operational control switches are "RESET".

If an emergency stop switch is not installed a jumper is required across the terminals.

### - ( 42 - 2 ) VOLTAGE SUPPLY

Terminals 42A (+) and 2 (-) provide a 3 amp fused (F1) systems battery voltage supply for accessories or optional devices. (12 or 24vdc)

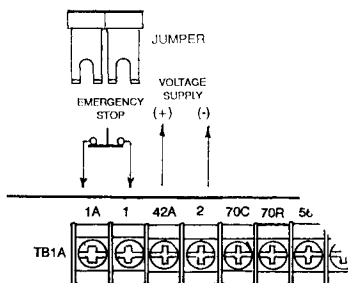

### - (70C) ENGINE COOLDOWN

Signal is provided for remote annunciation indicating that engine is running in the cooldown mode prior to a normal shutdown.

### - (70R) ENGINE RUN

Signal is provided for remote annunciation indicating the generator set is operating in a normal run condition.

### - (61) BATT. CHR.G. FAULT

### - (62) LOW BATT. VOLTAGE

### - (63) LOW FUEL LEVEL

A negative battery (-) signal placed on the terminal will light the corresponding indicator on the remote annunciator panel.

Signals are provided by battery charger fault relays or a fuel level switch.

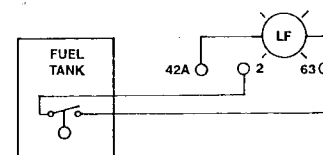
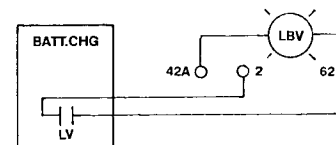
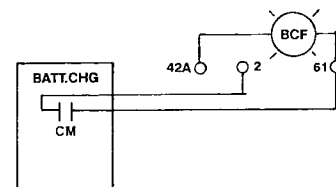

# CONTROLLER

## TB1 TERMINAL STRIP - DEC3+

The following terminals are output only and allow for connection to optional remote indicators or inputs to dry contact kits. The terminals provide a ground (-) output when the fault is activated and limited to 100 milliampere loads.

- (56) AIR DAMPER - A.D.
- (48) EMERGENCY STOP - E.S.
- (32A) COMMON FAULT - LINE 2\*
- (26) AUXILIARY - AUX.
- (12) OVERCRANK - O.C.
- (39) OVERSPEED - O.S.
- (38) LOW OIL PRESSURE - L.O.P.
- (36) HIGH ENG. TEMP. - H.E.T.
- (60) SYSTEM READY - S.R.
- (80) SW. NOT IN 'AUTO' - N.I.A.
- (41) PRE-LOW OIL PRESSURE - P.L.O.P.
- (32) COMMON FAULT - LINE 1\*
- (40) PRE-HIGH ENG. TEMP. - P.H.E.T.
- (35) LOW WATER TEMP. - L.W.T.

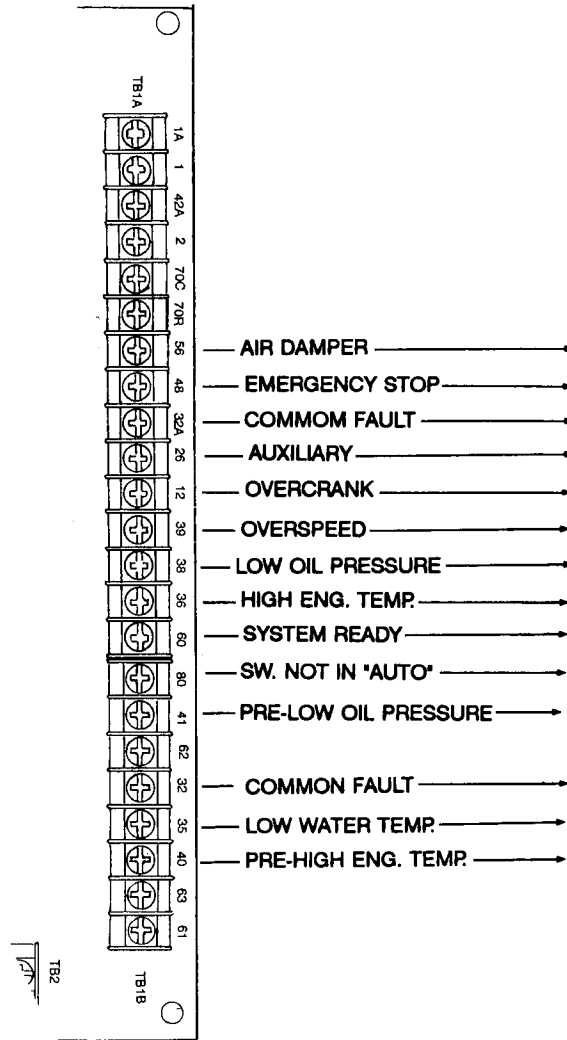

\* COMMON FAULT is used as an input signal for optional Audio-Visual Alarms. Two choices of Fault combinations are offered:

- (32) - Terminal will be at ground (-) potential when any of the 10 following faults occur:

- |                   |                      |
|-------------------|----------------------|
| - HIGH ENG.TEMP.  | - PRE-HIGH ENG. TEMP |
| - LOW OIL PRESS.  | - PRE-LOW OIL PRESS. |
| - LOW WATER TEMP. | - OVERCRANK          |
| - OVERSPEED       | - AUXILIARY          |
| - LOW FUEL        | - AIR DAMPER.        |

- (32A) - Terminal will be at ground (-) potential when any of the following 5 faults occur.

- |                   |                  |
|-------------------|------------------|
| - AUXILIARY       | - HIGH ENG.TEMP. |
| - LOW OIL PRESS.  | - OVERSPEED      |
| - EMERGENCY STOP. |                  |

The Common Fault Relay Kit can be used if a customer desires less or custom combinations of any of the above.

# CONTROLLER

## TB2 TERMINAL STRIP - DEC 3+

Barrier strip TB2 contains the engine starting control terminals.

### - ( 3 - 4 ) REMOTE START/STOP

When the status panel operational selector switch is placed in the "AUTO" position the generator set can be remotely started and stopped by a switch or dry set of contacts connected across terminals 3 - 4.

**Do not apply an external voltage.**

Open circuit voltage across 3(-) and 4(+) is 12vdc. The circuit draws approximately 42 milliamperes when completed.

Two 14 ga. conductors are recommended up to runs of 2000 ft. The conductors should be run in a conduit separate from the conduits used for generator load cables or battery charging cables to prevent radiated or induced signals to the circuit board.

When the circuit is opened after operating from a remote start the generator set will continue to run for an additional 5 minutes to allow for an Engine Cooldown.

### - ( 9 - 9A ) CRANK MODE

Cyclic engine cranking of 15 sec. crank with 15 sec. rest for a total of 75 seconds is standard. The cyclic feature can be eliminated by placing a jumper between terminals 9 and 9A. This will allow a continuous engine crank of 45 seconds on a start attempt prior to an "overcrank" termination.

### PRIME POWER FEATURE

This feature is provided for applications which do not require a remote automatic start and when battery drain must be kept to a minimum when in the "Off" mode.

Jumpers must be placed between terminals 1P - 2P, 3P - 4P and 3 - 4 to activate this feature. Alarm horn, LED indicators and remote start capabilities will be disabled.

An Engine start can only be activated manually from the local status panel by moving the switch from the "OFF/RESET" to the "AUTO" position. This will also rearm the alarm and indicator functions. There is no engine cooldown or remote start capability.

This feature will reduce battery drain to 200 microamperes with the unit at rest.

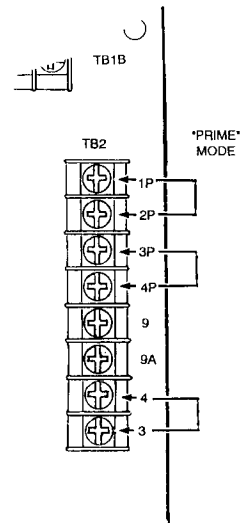
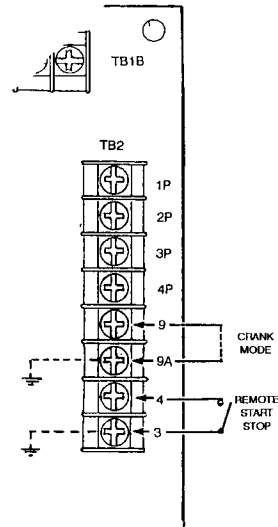

# CONTROLLER

## CONNECTORS: P1 P2 P3 (DEC 3+)

The majority of engine/generator condition inputs and engine control outputs are provided from the harness connector P1.

AC input for voltage sensing and optional overvoltage shutdown signal as well as DC output to the instrument panel engine gauges and illumination lamps is provided by the P2 plug connector.

The signal for the 'AIR DAMPER' indicator on the Status Panel is also supplied from the P2 connector.

The P3 20 terminal plug provides interconnection to the Status Panel switches and indicators via a ribbon harness. Fault signals to the P3 are common to the TB1 terminals.

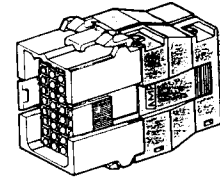
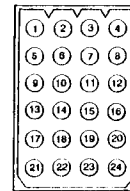
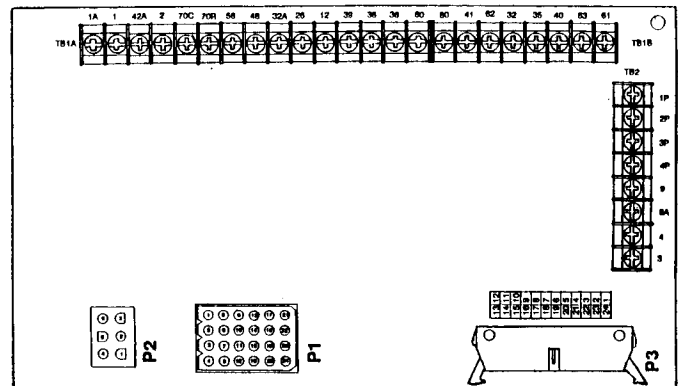

P1

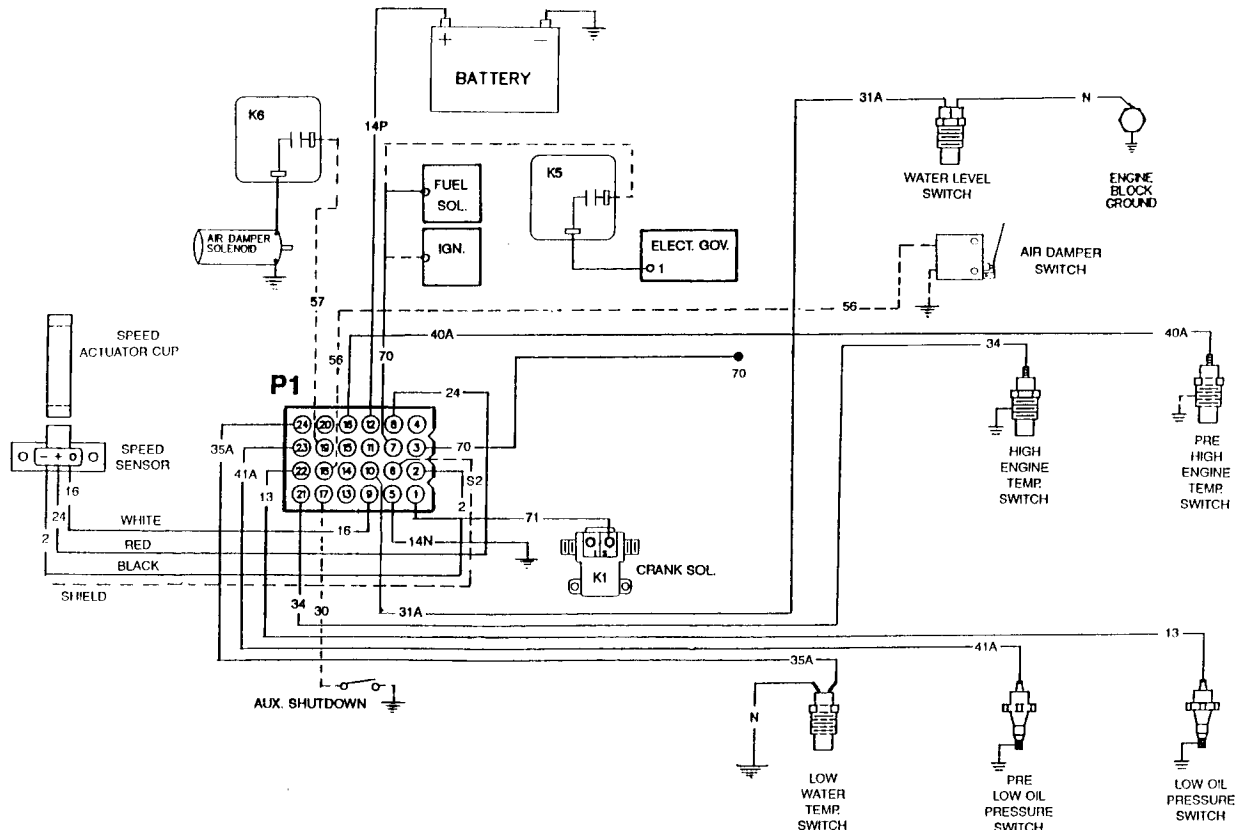

# CONTROLLER

## P2 CONNECTOR

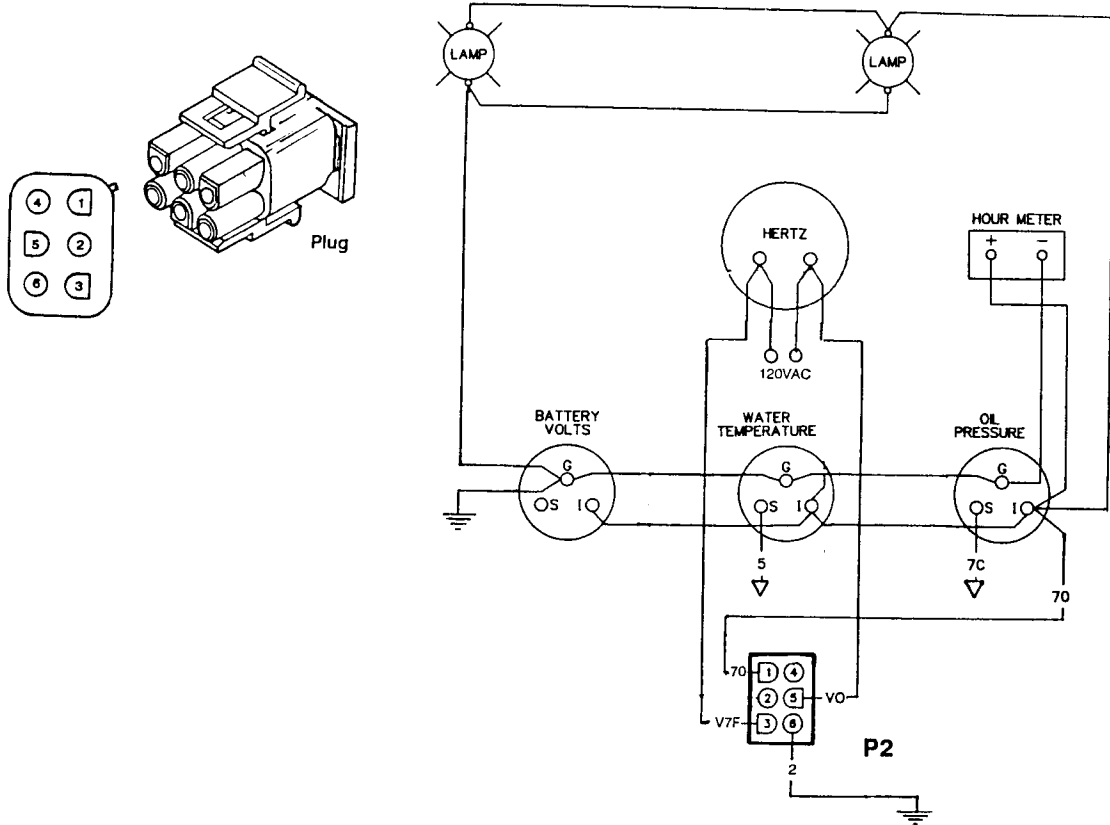

## P3 CONNECTOR

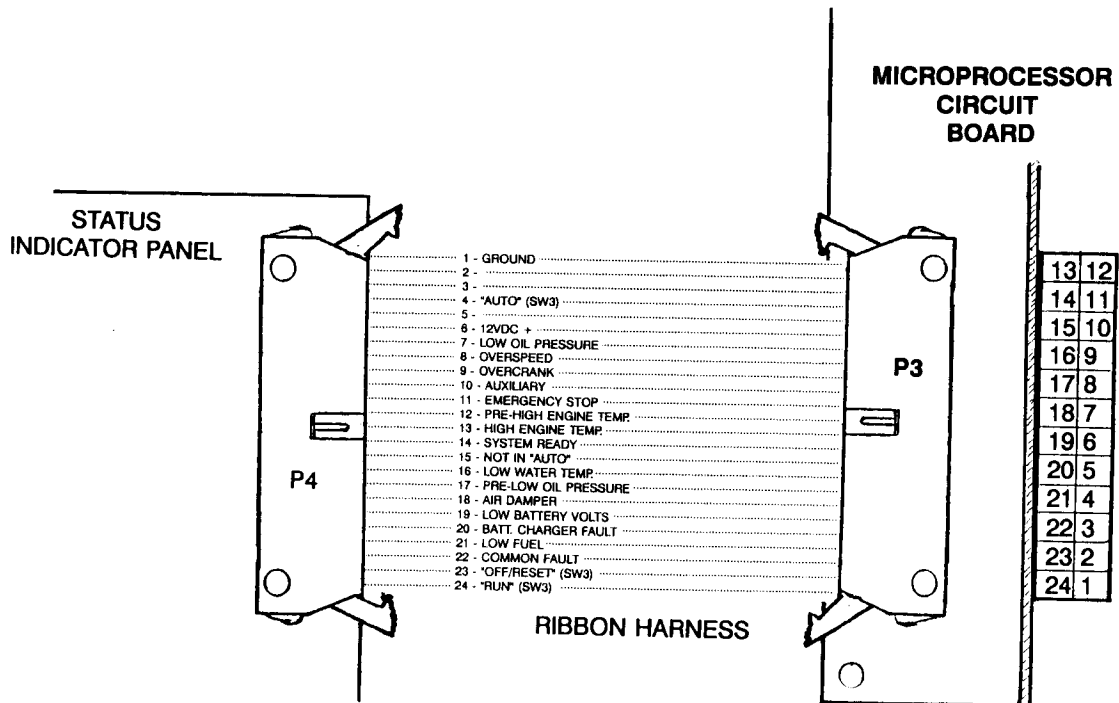



# CONTROLLER

## FUSES; F1 - F2 - F3 (DEC 3+)

The three fuses are located in holders soldered to the microprocessor circuit board and protect the wiring and circuit foil from damage in the event of excessive fault currents.

The **F1** fuse provides overcurrent protection from accessories or options powered from terminal 42A on the TB1 terminal strip. The 3 Amp fuse is rated at 250 volts.

The **F2** fuse protects the circuits powering the main logic and relay coils on the microcomputer board as well as the Status/Indicator panel. It is also a 3 Amp, 250 volt fuse.

The **F3** fuse provides circuit protection if faults occur on engine electrical components powered through the K2 and K3 relay contacts. The ceramic fuse is rated at 15 amps/ 250v.

## RELAYS; K2 - K3 - K4 (LED'S 1,2,3)

The (3) 12vdc sealed relays soldered to the circuit board provide controlled output power to the generator sets DC electrical components: Start solenoid, Fuel valves, Governor control, Fuel pump, Ignition, Voltage regulator, Solenoids, Slave relays etc. Red LED's are connected across the relay coils to indicate when voltage is applied to the coils.

The **K2** relay provides the cranking control to the engine starter crank solenoid (K1). When an engine start command is initiated the logic circuit will cyclicly energize the relay coil, 15 seconds on and 15 seconds off for a total time of 75 seconds. This cyclic mode can be changed to 75 seconds of continuous energizing by placing a jumper between terminals 9 and 9A of the TB2 terminal strip.

The **K3** relay provides battery voltage supply (12 or 24vdc) to the engine, generator and controller components required for normal 'run' operation. It remains energized during a start/run command and is deenergized 5 minutes after a remote stop command or immediately on an emergency stop signal.

A normally open set of **K4** contacts are in series with both the K2 and K3 relay coils. The **K4** relay (emergency stop), must be energized before an engine crank and run can occur. If the circuit to the K4 coil is disrupted both the K2 and K3 relays will be deenergized. The emergency stop switch when used is connected in series with the K4 relay coil. (TB1 terminals 1 - 1A)

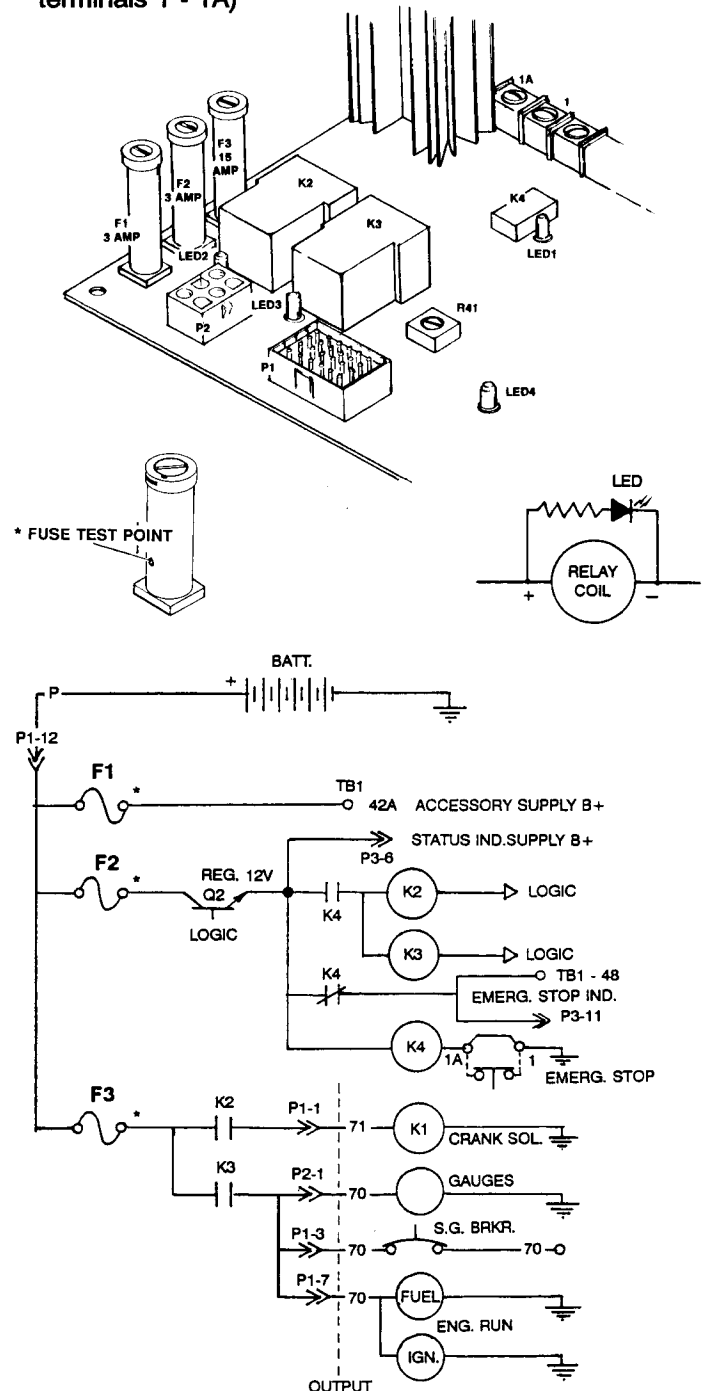

# CONTROLLER

## DEC 3+ OVERVOLTAGE SHUTDOWN

An Overvoltage protection circuit is provided on the Dec 3+ circuit board. The feature is factory adjusted to shut down the generator set if the output voltage exceeds 115% of the nominal voltage setting for longer than 2 seconds\*.

A potentiometer (R41) and Light Emitting Diode (LED4) are provided on the board for field adjustment. The LED will indicate when the overvoltage occurs. Clockwise rotation of R41 will increase the voltage trip point.

A shutdown due to an overvoltage condition will cause the Auxiliary indicator on the local and remote status annunciator panels to light.

### NOTE \*

Equipment sensitive to Voltage specifications above this rating require additional field installed protective devices.

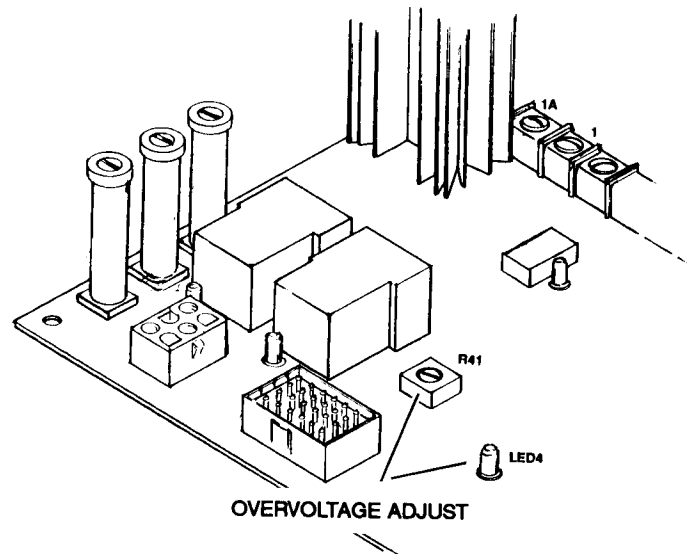

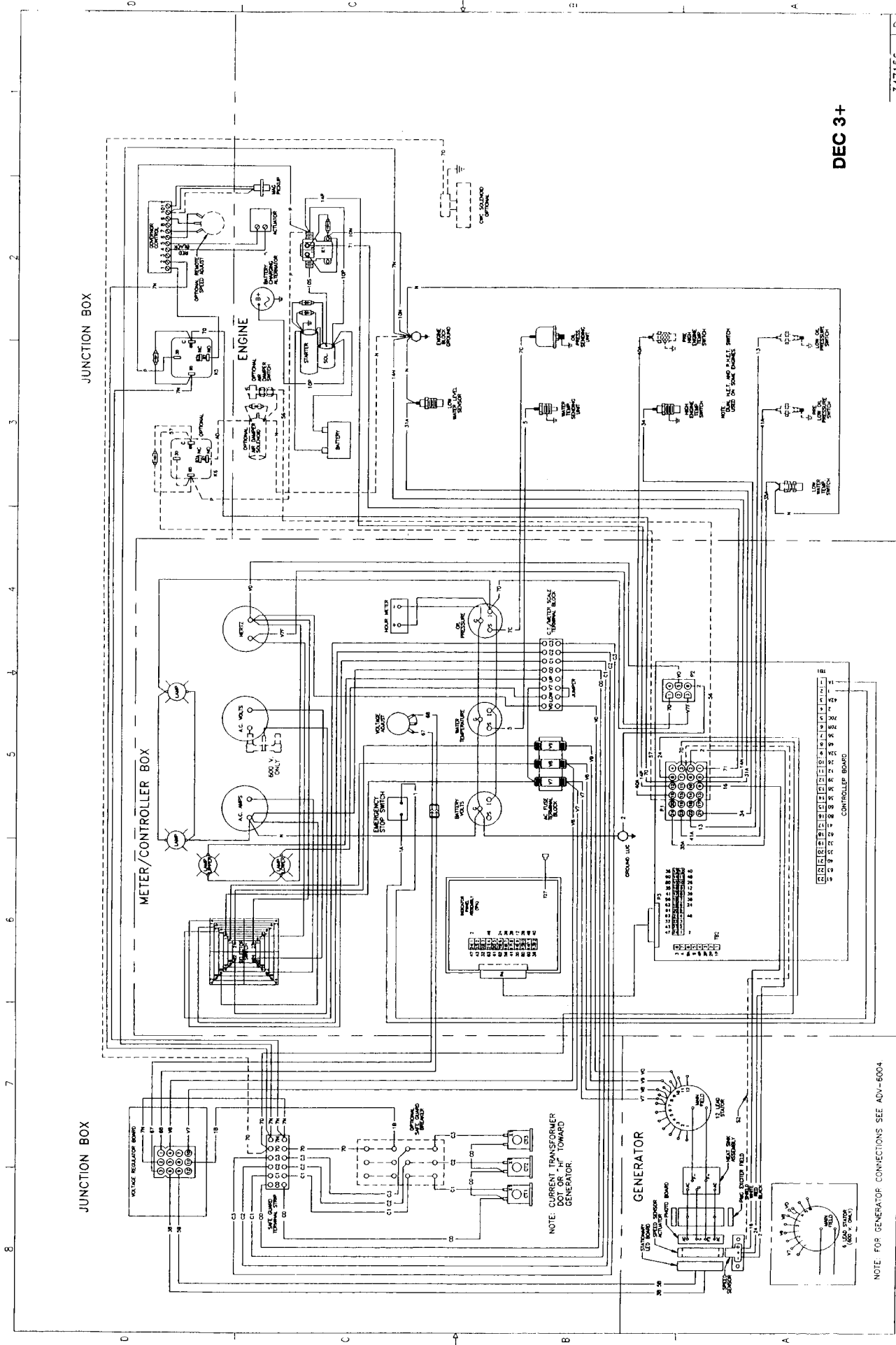

DEC 3+

NOTE: FOR GENERATOR CONNECTIONS SEE ADV-6004

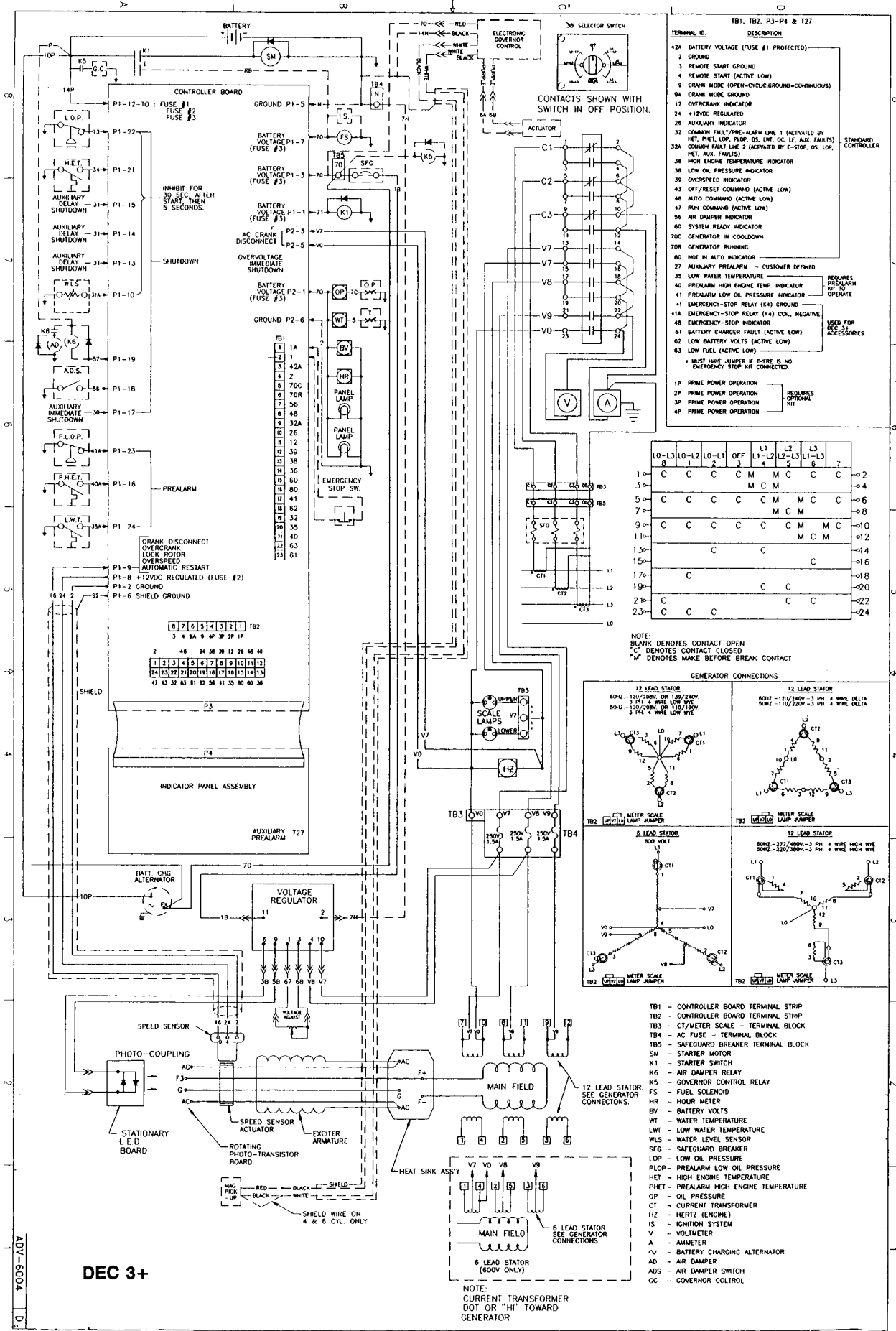

TERMINAL ID DESCRIPTION

1	BATTERY VOLTAGE (FUSE #1 PROTECTED)
2	GROUND
3	REMOTE START GROUND
4	REMOTE START (ACTIVE LOW)
9	CRANK MODE (OPEN=CYCLIC,GROUND=CONTINUOUS)
9A	CRANK MODE GROUND
12	OVERCRANK INDICATOR
24	+12VDC REGULATED
26	AUXILIARY INDICATOR
32	COMMON FAULT/PRE-ALARM LINE 1 (ACTIVATED BY HET, PREL, LOP, PLOP, OLS, LWT, OC, LF, AUX. FAULTS)
32A	COMMON FAULT LINE 2 (ACTIVATED BY E-STOP, OLS, LOP, HET, AUX. FAULTS)
38	HIGH ENGINE TEMPERATURE INDICATOR
39	LOW OIL PRESSURE INDICATOR
39	OVERSPEED INDICATOR
43	OFF/RESET COMMAND (ACTIVE LOW)
46	AUTO COMMAND (ACTIVE LOW)
47	RAW EXHAUST (ACTIVE LOW)
56	AIR DAMPER INDICATOR
60	SYSTEM READY INDICATOR
70C	GENERATOR IN COOLDOWN
70R	GENERATOR RUNNING
80	NOT IN AUTO INDICATOR
27	AUXILIARY PRE-ALARM - CUSTOMER DEFINED
35	LOW WATER TEMPERATURE
40	PRE-ALARM HIGH ENGINE TEMP. INDICATOR
41	PRE-ALARM LOW OIL PRESSURE INDICATOR
41	EMERGENCY-STOP RELAY (K4) GROUND
46	EMERGENCY-STOP INDICATOR
61	BATTERY CHARGER FAULT (ACTIVE LOW)
62	LOW BATTERY VOLTS (ACTIVE LOW)
63	LOW FUEL (ACTIVE LOW)

1P PRIME POWER OPERATION  
2P PRIME POWER OPERATION  
3P PRIME POWER OPERATION  
4P PRIME POWER OPERATION

REQUIRES PRE-ALARM KIT TO OPERATE  
USED FOR DEC. 3+ ACCESSORIES  
REQUIRES OPTIONAL KIT

LO-L3	LO-L2	LO-L1	OFF	L1	L2	L3	L1-L3	7
1	2	3	4	5	6	7	8	9
1-0	C	C	C	M	C	C	C	→2
3-0				M	C	M		→4
5-0	C	C	C	C	M	C	C	→6
7-0					M	C	M	→8
9-0	C	C	C	C	C	M	M	→10
11-0						M	C	→12
13-0				C				→14
15-0						C		→16
17-0				C				→18
19-0						C	C	→20
21-0	C	C	C					→22
23-0	C	C	C					→24

NOTE:  
BLANK DENOTES CONTACT OPEN  
"C" DENOTES CONTACT CLOSED  
"M" DENOTES MAKE BEFORE BREAK CONTACT

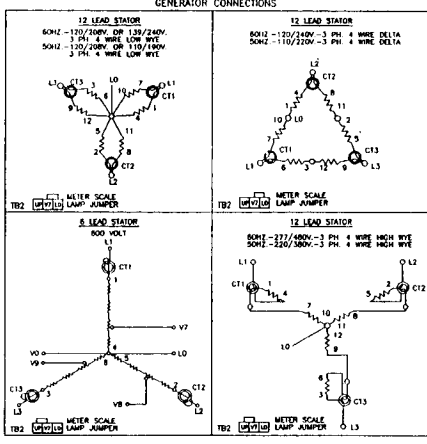

- TB1 - CONTROLLER BOARD TERMINAL STRIP
- TB2 - CONTROLLER BOARD TERMINAL STRIP
- TB3 - CT/METER SCALE - TERMINAL BLOCK
- TB4 - AC FUSE - TERMINAL BLOCK
- TB5 - SAFEGUARD BREAKER TERMINAL BLOCK
- SM - STARTER MOTOR
- K1 - STARTER SWITCH
- K6 - AIR DAMPER RELAY
- K5 - GOVERNOR CONTROL RELAY
- FS - FUEL SOLENOID
- HR - HOUR METER
- EV - BATTERY VOLTS
- WT - WATER TEMPERATURE
- LWT - LOW WATER TEMPERATURE
- WLS - WATER LEVEL SENSOR
- SFG - SAFEGUARD BREAKER
- LOP - LOW OIL PRESSURE
- PLOP - PRE-ALARM LOW OIL PRESSURE
- HET - HIGH ENGINE TEMPERATURE
- PHET - PRE-ALARM HIGH ENGINE TEMPERATURE
- OP - OIL PRESSURE
- CT - CURRENT TRANSFORMER
- HZ - HERTZ (ENGINE)
- IS - IGNITION SYSTEM
- V - VOLTMETER
- A - AMPHETER
- ~ - BATTERY CHARGING ALTERNATOR
- AD - AIR DAMPER
- ADS - AIR DAMPER SWITCH
- GC - GOVERNOR CONTROL

NOTE: CURRENT TRANSFORMER DOT OR "H" TOWARD GENERATOR

# CONTROLLER

## MANUAL CONTROLLER

This Manual Controller provides a simple relay control with full generator metering and engine condition gauges as well as Overspeed, Low oil pressure, High coolant temperature and Low coolant level shut down protection.

It is designed for local manual starting and stopping of the generator set. Remote starting capabilities and overcrank protection are not provided.

The relay control circuit board features LED's connected across the relay coils for diagnostic aid when servicing.

Along with the relay control circuit board a combination Overspeed / Time Delay board is incorporated.

The Overspeed (Overfrequency) circuit monitors the generator AC output and will energize the stop relay if a generated frequency above 70 Hz occurs.

The TD (time delay) portion of the board provides a set of contacts to delay energizing of the low oil pressure shutdown circuit during cranking and start-up.(5 Sec.)

The "run" circuit is interlocked when an AC signal is available from the generator output. A transformer located in the controller cabinet provides 12vac to the circuit. A time delay (TD) for engine oil pressure build-up is also provided in the interlock circuit.

The common fault lamp will light when the stop circuit is energized.

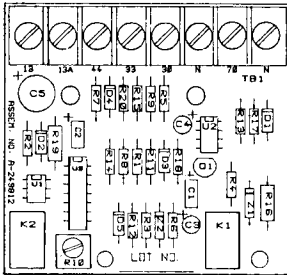
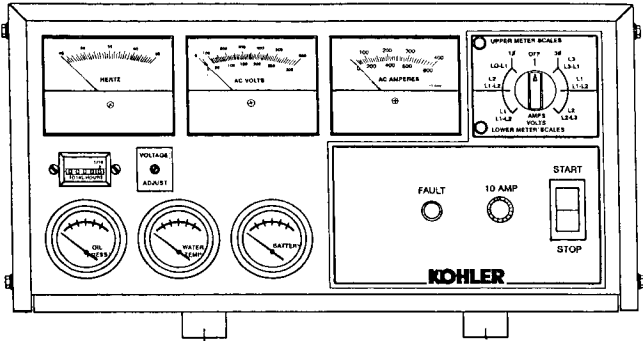

OVERSPEED/TD BOARD

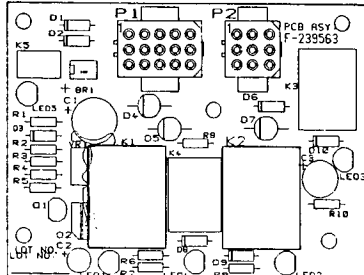

CONTROL BOARD

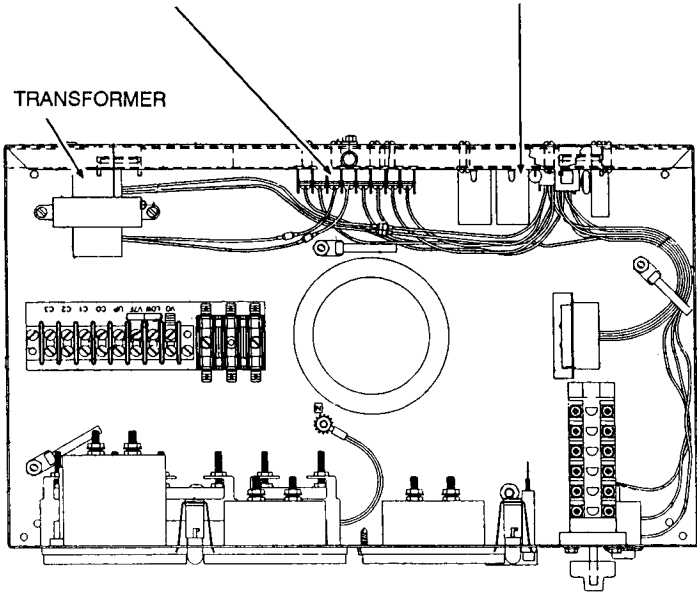

TRANSFORMER

# CONTROLLER

## MANUAL CONTROLLER

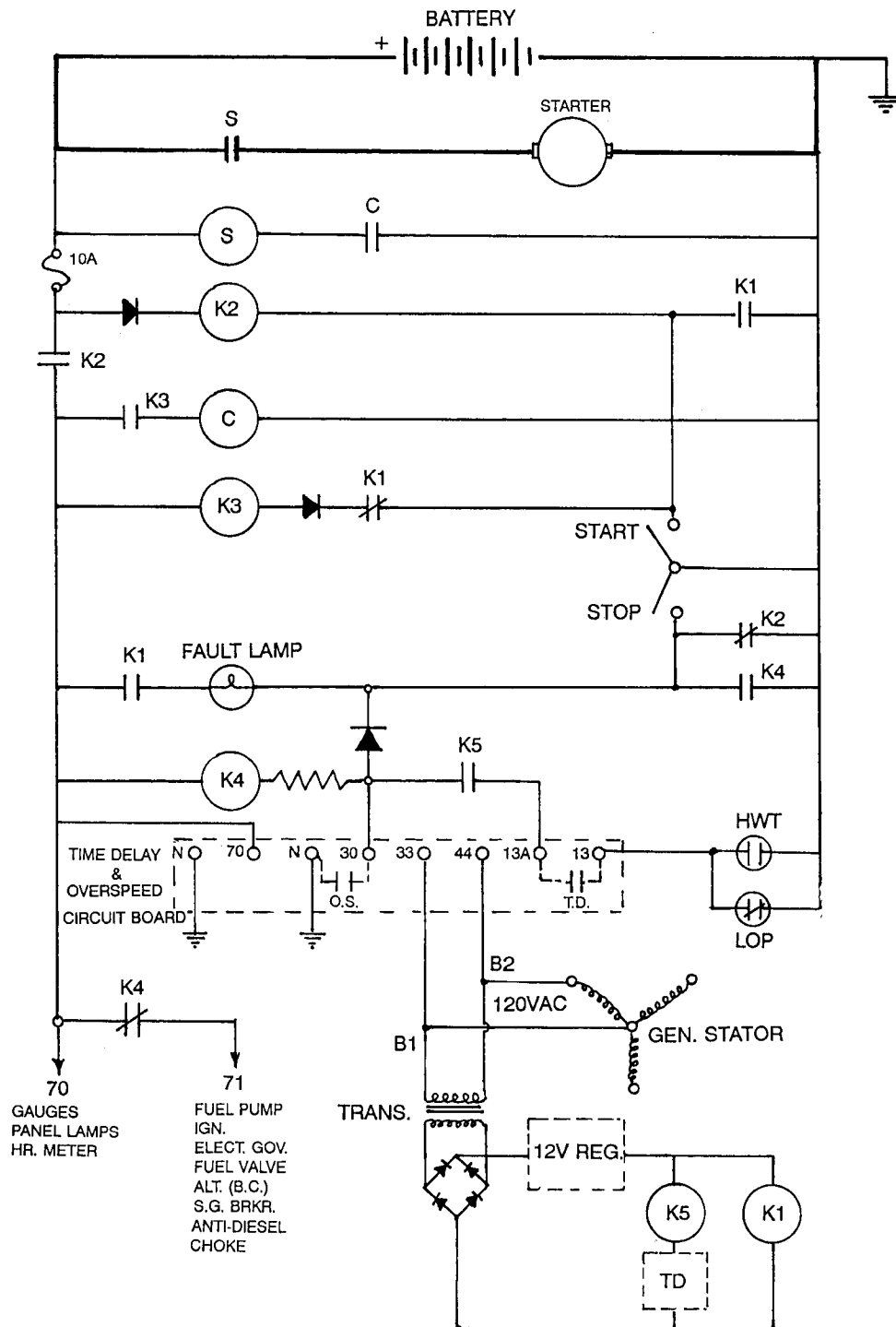

# CONTROLLER

## DEC 3+ CONTROLLER (7 LAMP)

The seven lamp controller is offered for level 2 applications not as stringent as installations requiring the NFPA-110 level 1 (16) lamp controller.

This controller incorporates all the components of the standard DEC 3+ but provides only 7 indicator lamps on the status panel. These include:

- OVERCRANK
- LOW OIL PRESSURE
- OVERSPEED
- HIGH ENG. TEMP.
- LOW WATER TEMP.
- AUXILIARY \*
- AIR DAMPER

\*

The AUXILIARY lamp will flash if no generated A.C. or low battery voltage is sensed.

The AUXILIARY lamp will light on Emergency Stop, Overvoltage Shutdown, Low Water Temperature, or Auxiliary customer supplied devices.

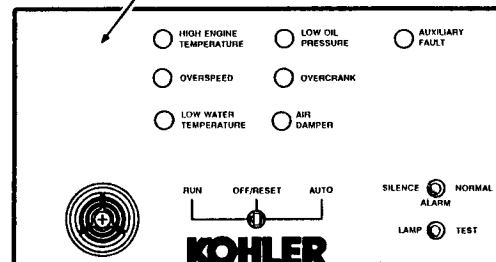
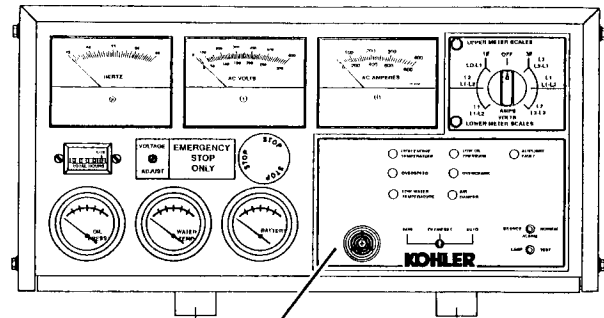





# CONTROLLER

## PARALLELING / ENG. GAUGE BOX

This Control cabinet allows the generator set to be interconnected with switchgear-mounted engine control logic for parallel operation.

All engine/generator controls and metering are mounted in the switchgear cabinet with exception of an electronic speed switch and emergency stop switch if one is required.

The governor magnetic pick-up provides the electronic switch with the flywheel speed signal for engine crank termination as well as overspeed shutdown.

Terminal strips are provided for customer interconnection of the governor, crank relays, safety shutdown and gauge senders to the switchgear cabinet.

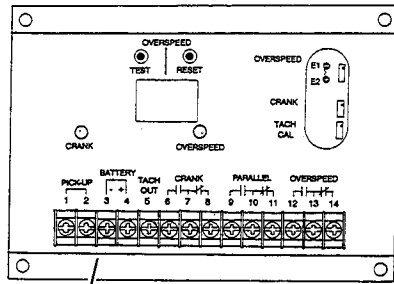
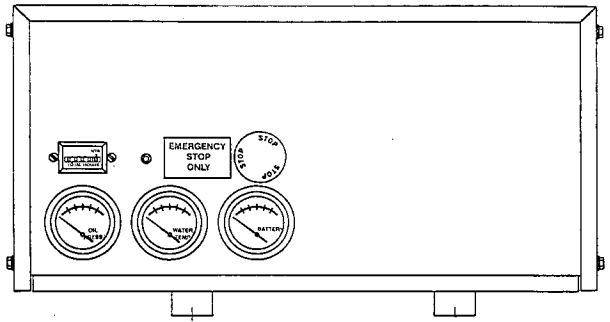

**ELECTRONIC SPEED SWITCH**

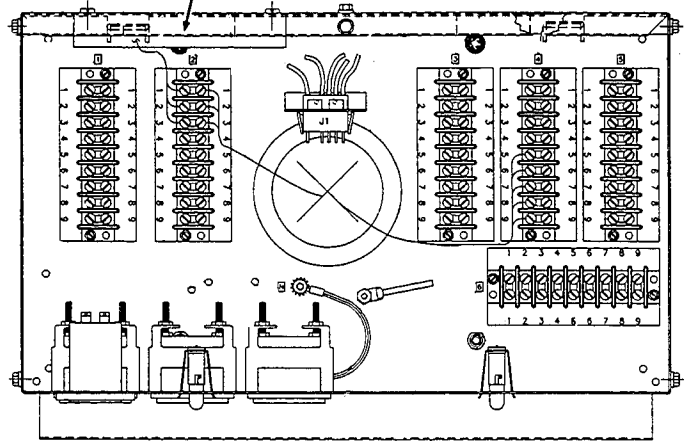

# CONTROLLER

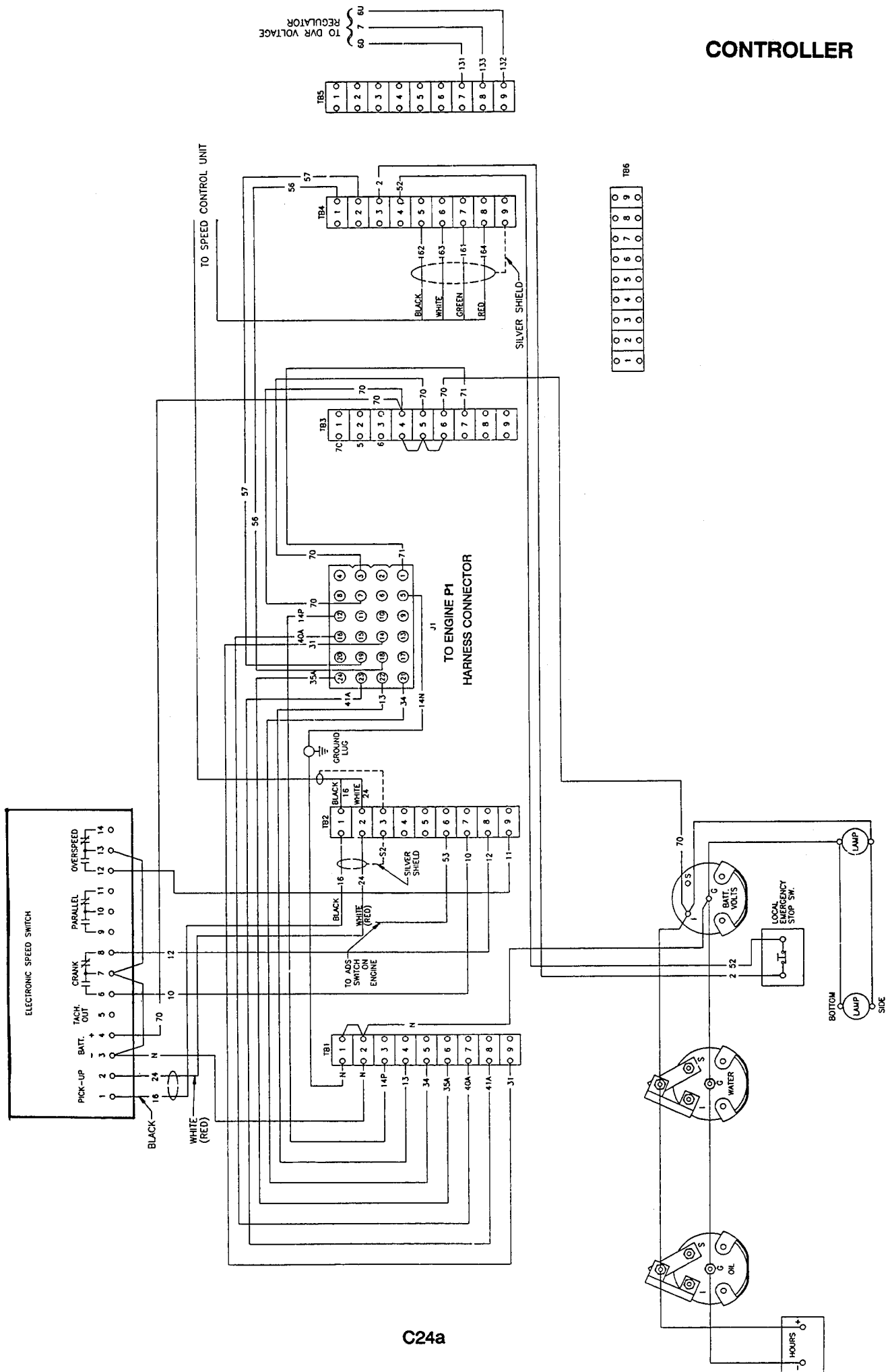

C24a

# CONTROLLER

## DEC 1 CONTROLLER

The Decision Maker 1 series provides a cost effective controller for applications that require remote or automatic start capability but compliance with NFPA requirements is not necessary.

The Start Selector switch has positions for local (RUN) or remote (AUTO) operation as well as logic resetting after a fault shut-down.

A common fault lamp is provided for indication of a shut-down due to:

- OVERCRANK
- OVERSPEED
- HIGH ENGINE TEMPERATURE
- LOW OIL PRESSURE
- LOW COOLANT LEVEL

The panel mounted input fuse, running time meter and voltage regulator adjust are also standard on all DEC 1 controllers.

Terminals 3 - 4 on the TB1 strip are provided for dry contact remote starting.

A 15 amp fuse and K5 relay are also located in the cabinet and provide controlled battery voltage to the engine gauges, fuel system, voltage regulator and battery charging alternator excitation circuit.

The electric governor control is also located in the controller cabinet.

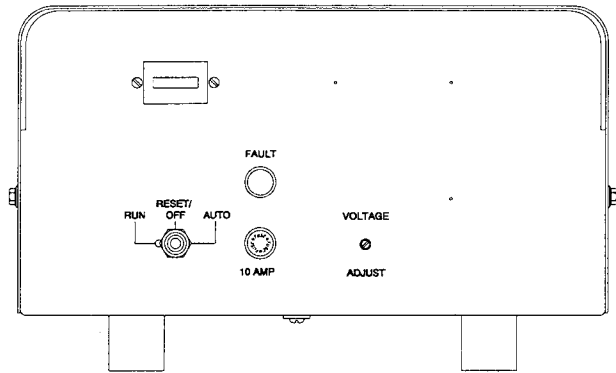

STANDARD DEC 1

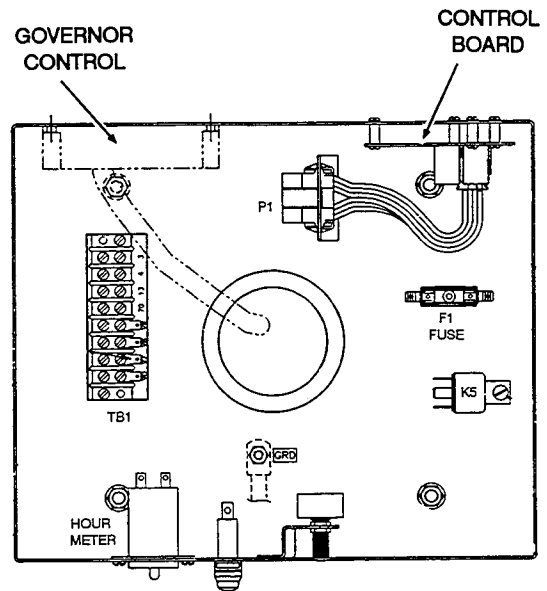

# CONTROLLER

## DEC 1 CONTROLLER

The logic circuit board contains 4 relays for control of cranking, crank disconnect, run or auto-start and fault indication. LEDs are connected across the relay coils for operation analysis.

The control circuit is interlocked by the generated AC to prevent starter motor reengagement during running. Low oil pressure, High engine temperature and Low coolant level fault shutdowns are delayed for 5 seconds and inhibited during cranking.

Automatic cranking termination on failure to start within 30 seconds (OVERCRANK) as well as an engine shut-down due to an OVERSPEED (70 Hz) is standard and factory set.

The DEC 1 controller is also available with gauges for engine monitoring or with an expanded cabinet which includes AC metering as well as engine gauges.

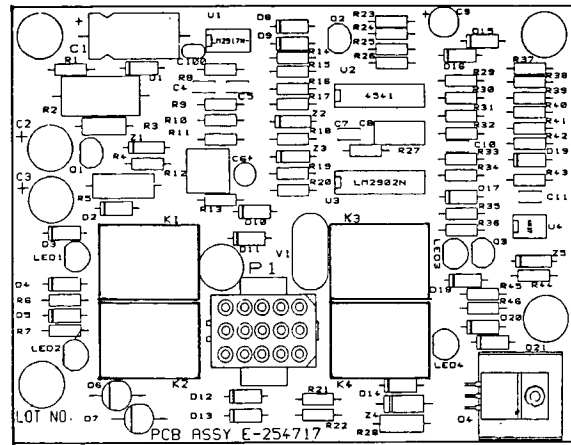

LOGIC CIRCUIT BOARD

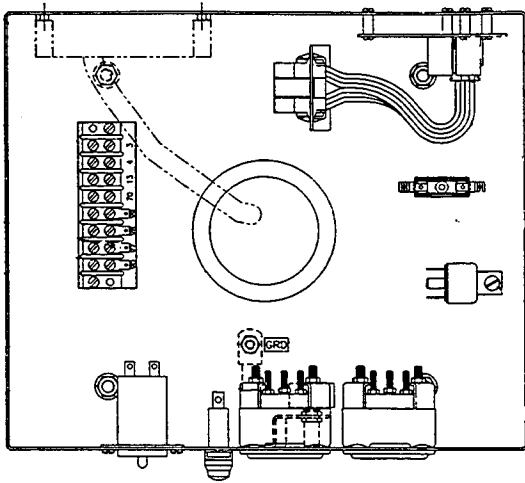

DEC 1 W/GAUGES

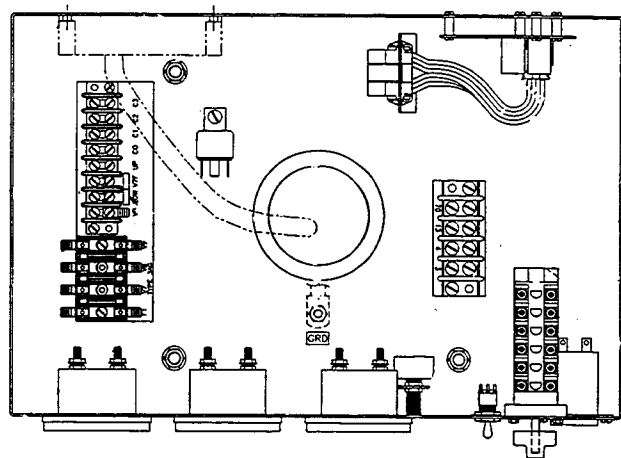

DEC 1 W/GAUGES & METERS

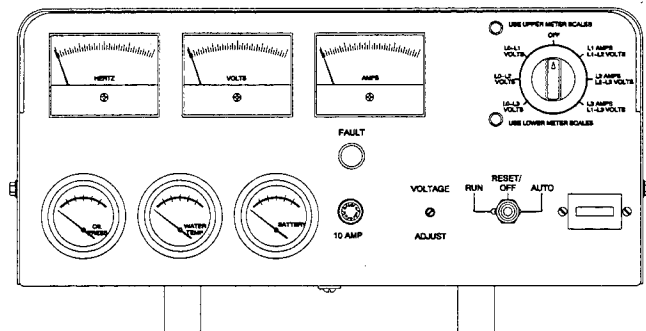
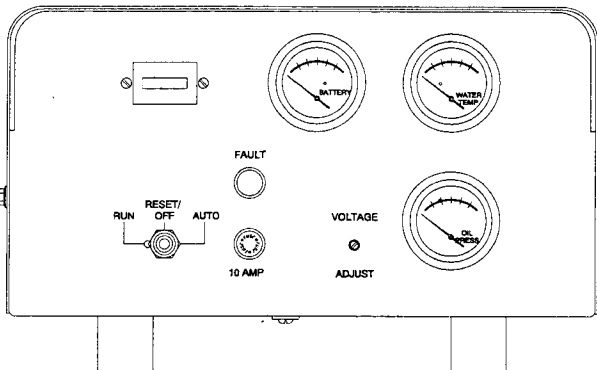

# CONTROLLER

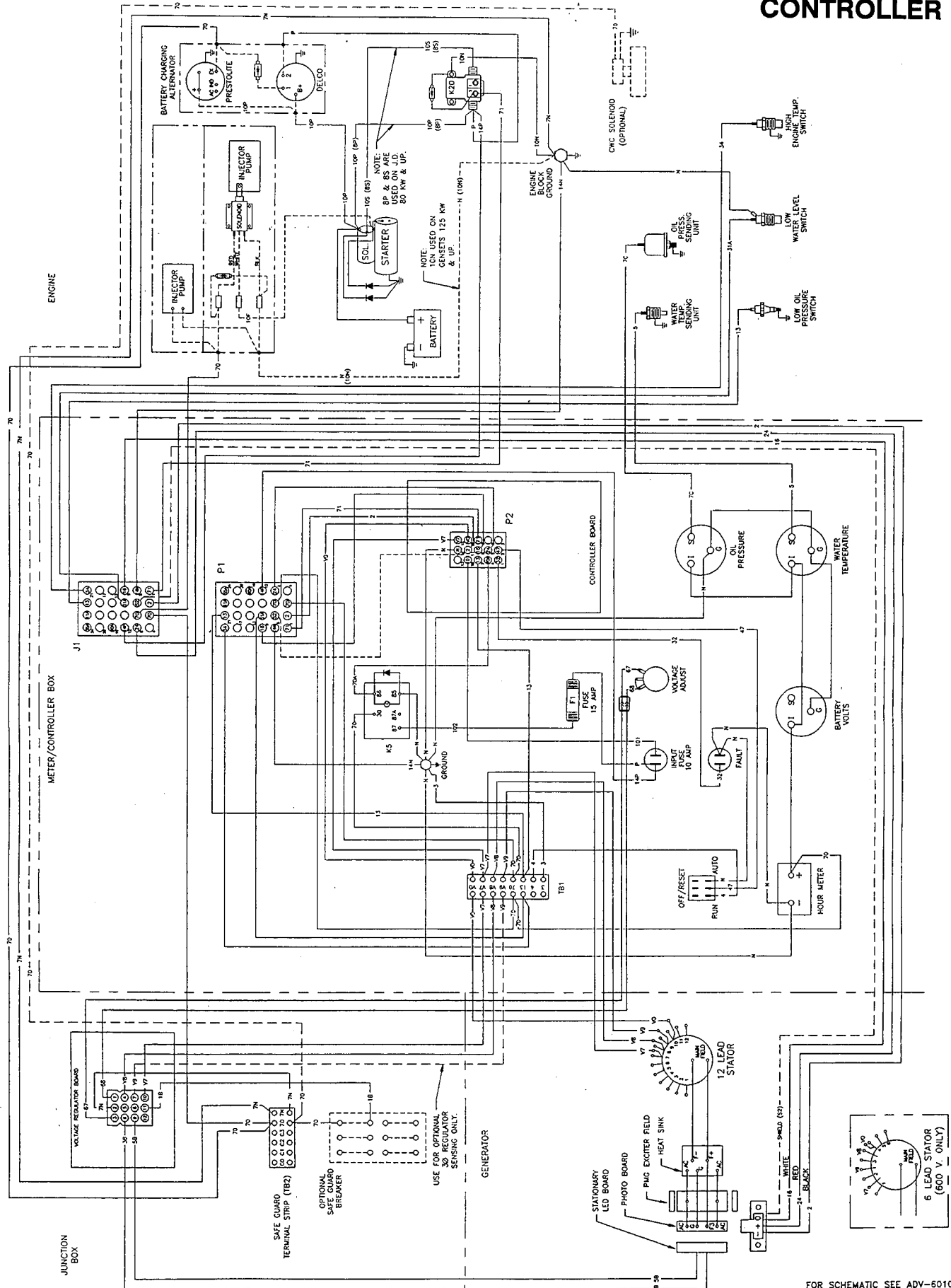

FOR SCHEMATIC SEE ADV-6010

<b>KOHLER CO.</b> COGNATE DIVISION, 1200 N. 20th St., Milwaukee, Wis. 53217, U.S.A. ALL RIGHTS RESERVED. NO PART OF THIS PUBLICATION MAY BE REPRODUCED OR TRANSMITTED IN ANY FORM OR BY ANY MEANS, ELECTRONIC OR MECHANICAL, INCLUDING PHOTOCOPYING, RECORDING, OR BY ANY INFORMATION STORAGE AND RETRIEVAL SYSTEM, WITHOUT PERMISSION IN WRITING FROM KOHLER CO.	
<b>DECISION-MAKER 1 W/ GAUGES SPLIT ACTIVATOR DIESEL 20-180 KW</b>	
DATE: 6-8-92 DRAWN BY: [blank] CHECKED BY: [blank]	TITLE: <b>DIAGRAM, WIRING</b> SHEET: 1-1 FILE NO: 347327.DWG PART NO: 347327

# CONTROLLER

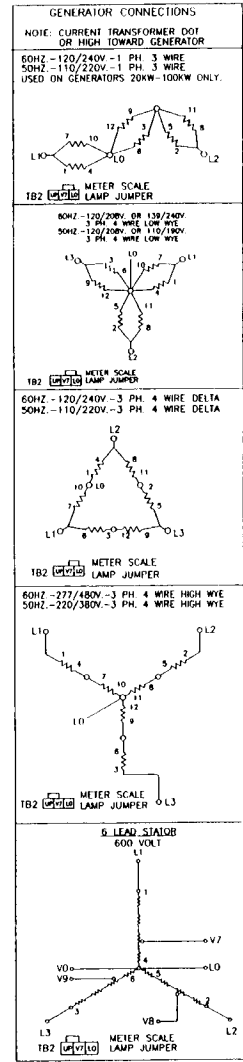
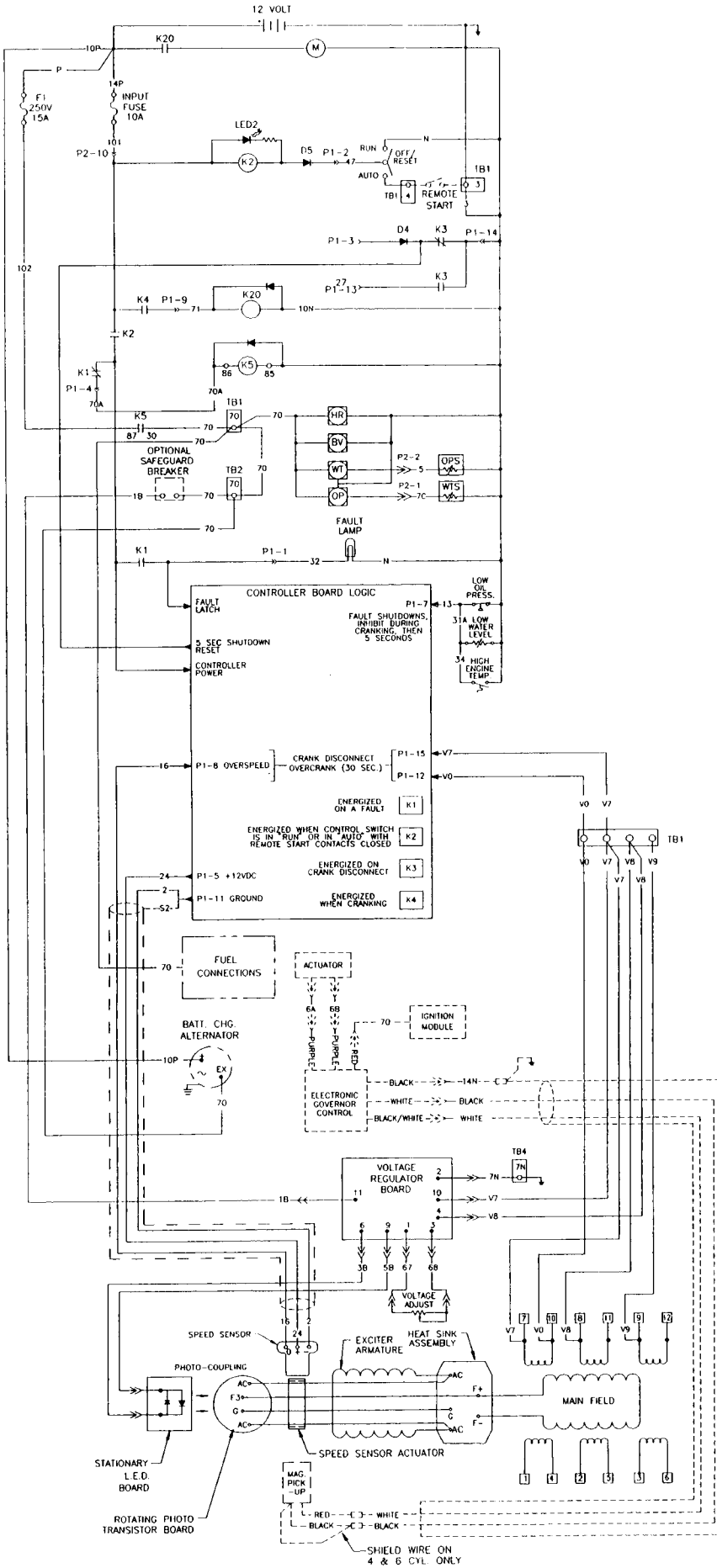

- LEGEND**
- BV - BATTERY VOLTMETER
  - F1 - FUSE, 250V, 15A
  - HR - HOUR METER
  - K1 - FAULT SHUTDOWN RELAY
  - K2 - ENGINE RUN RELAY
  - K3 - CRANK DISCONNECT/FLASHING CONTROL RELAY
  - K4 - CRANK DISCONNECT RELAY
  - K5 - AUX. RUN RELAY
  - K20 - STARTER RELAY SOLENOID
  - M - STARTER MOTOR
  - OP - OIL PRESSURE GAUGE
  - OPS - OIL PRESSURE SWITCH
  - TB1 - REMOTE START TERM. BLOCK
  - TB2 - SAFEGUARD BRAKER TERM. BLOCK
  - WTS - WATER TEMPERATURE SENSITR
  - - - USED ON FORD LSC-875 ENGINE ONLY

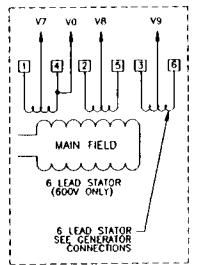

<b>KOHLER CO.</b> GENERATOR DIVISION, BOSTON, MASS. U.S.A. <small>THIS DRAWING IS THE PROPERTY OF KOHLER CO. AND IS NOT TO BE USED IN CONNECTION WITH ANY OTHER PRODUCT OF KOHLER CO. WITHOUT THE WRITTEN PERMISSION OF KOHLER CO.</small>	
<b>DIAGRAM, SCHEMATIC</b>	
APPROVALS	DATE
DESIGNED BY: RAR	6-8-95
CHECKED BY: [ ]	DATE: [ ]
REVISED BY: [ ]	DATE: [ ]
DATE: [ ]	DATE: [ ]

20-180 KW  
 SPLIT ACTIVATOR 19-30 & 600V  
 DECISION-MAKER 1 W/ GAUGES  
 ADV-6010

# CONTROLLER

## Decision-Maker™ 340

The Decision Maker™ 340 is optional on generator sets from 20 to 2000kW and meets the NFPA requirements of NFPA-99 and NFPA-110.

The Controller contains microcomputer-based logic and can be communicated with a PC individually or on a network when equipped with optional communication products.

The controller is compatible with 12 or 24 volt engine battery systems.

The Display provides both Engine and Generator condition as well as numerous system functions.

The Controller Monitors engine and generator parameters and displays and stores shutdown history.

Generator and Transfer Switches can be remotely monitored and controlled over phone lines using menu driven software.

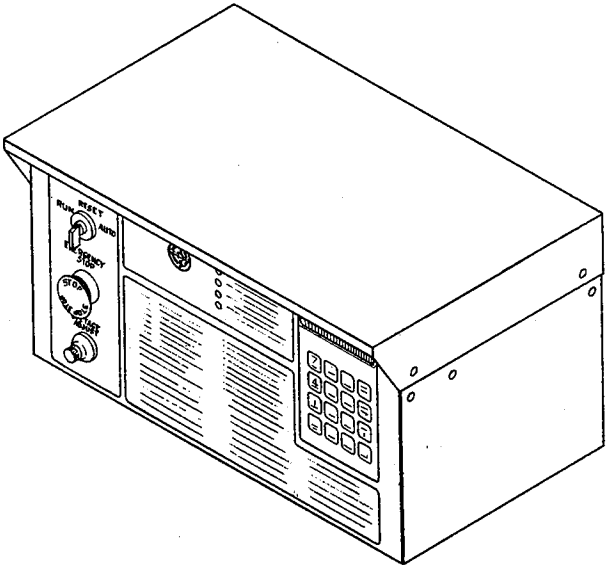

**OFF/  
RUN RESET AUTO**



**EMERGENCY  
STOP**



**VOLTAGE  
ADJUST**



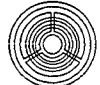

- System Ready
- Not In Auto
- Program Mode
  - Flashing, Local
  - Steady, Remote
- System Warning
- System Shutdown

**Operating Guide**

Menu No.	Description
1	Generator Output
2	Operational Records
3	Time & Date
4	Time Delays
5	User Defined Functions
6	Generator System
7	Engine Status
8	Source History
9	Calibration
10	Remote Control
11	Programming Mode

**To Enter & Exit a Menu:**

- Press RESET MENU key.
- Press MENU ← key to scan menus or enter menu number.
- Press MENU ↓ key.
- MENU ↓ key vertically scans menu.
- MENU → key horizontally scans menu.
- Press RESET MENU key to exit menu.

**Lamp Test:**

- Press RESET MENU key.
- Press LAMP TEST key.

**To Set Time & Date:**

- Select Local programming mode.
- Press RESET MENU key.
- Press 3, for Time & Date.
- Press MENU ↓ key twice.
- Enter Hours, Minutes and AM/PM.
- Press ENTER ↓ key.
- Press MENU ↓ key twice.
- Enter Month—Day—Year.
- Press ENTER ↓ key.

**To Manually Store Set Points:**

- Select Local programming mode.
- Press RESET MENU key.
- Press ENTER ↓ key.

**Programming Mode:**

- Enter code to select mode.
- Off permits monitoring only.
- Local permits adjustment using keypad.
- Remote permits adjustment using remote computer.

**To Stop Programmed Engine Run:**

- Press STOP PROG RUN key.

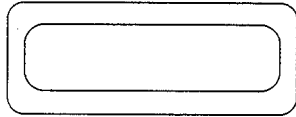

7  
YES

8  
NO

9  
MON

RESET  
MENU

4  
TUE

5  
WED

6  
THU

MENU  
→

1  
FRI

2  
SAT

3  
SUN

MENU  
↓

0  
LAMP  
TEST

ALARM  
OFF  
AM/PM

STOP  
PROG  
RUN

ENTER  
←

**System Shutdown or System Warning Lamp On:**

- See display for message.
- Clear fault, then set the MASTER SWITCH to the OFF/RESET position.
- Press RESET MENU key.

**Not in Auto Lamp On:**

- To clear, set the MASTER SWITCH in the AUTO position.

# CONTROLLER

The **RUN-OFF/RESET-AUTO** switch is a 3 position, rotary, selector switch.

**RUN** - position is used to start the generator set locally.

**AUTO** - position is used when starting and stopping is to be controlled remotely.

**OFF/** - Will stop the generator set without any time delay when operating locally from the **RUN** position.

**/RESET** - When the generator set shuts down due to a fault, the control system must be reset by moving the selector to the center off position prior to a restart.

Pressing the **EMERGENCY STOP** switch bypasses any time delays and provides an immediate engine shutdown when operating in the **AUTO** position. The switch will latch in the open position and can be reset by rotating it 1/4 turn clockwise.

A **VOLTAGE ADJUST** potentiometer is provided on controllers installed on FR generator sets (20 - 300kW). On generators with digital regulators voltage adjust is controlled with the keypad.

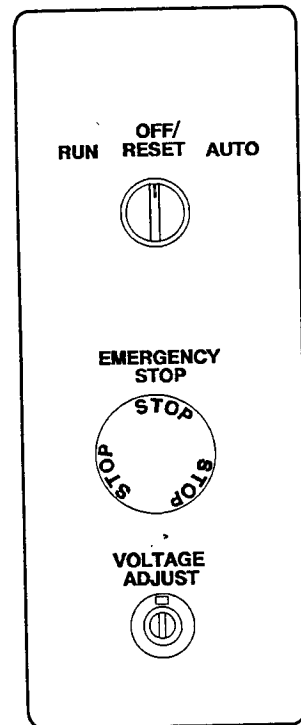



# CONTROLLER

## DIGITAL DISPLAY & KEYPAD

The KEYPAD is used to locally interact with the controller by accessing generator set data & preset settings.

Crank cycles as well as time delays can be easily programmed with the Keypad. Pressing any key activates the controller panel display.

All generator and engine monitoring including RPM, Power Factor, kilowatt hours and percent of max. kW is readily accessible on the DISPLAY. Overloads result in a load shed function.

There are 11 menus available:

- Generator output
- Operational Records
- Time & Date
- Time Delays
- User Defined Functions
- Generator System
- Engine Status
- Source History
- Calibration
- Remote Control
- Programming Mode

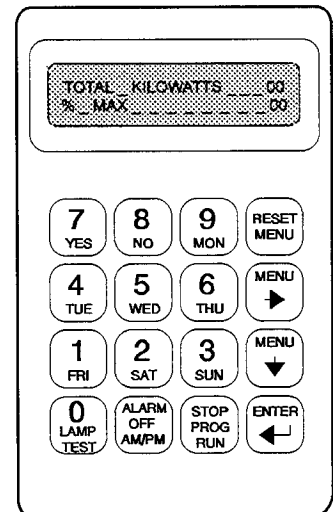

Operating Guide Menu No.	Description	To Set Time & Date:
1	Generator Output	○ Select Local programming mode.
2	Operational Records	○ Press RESET MENU key.
3	Time & Date	○ Press 3, for Time & Date.
4	Time Delays	○ Press MENU ↓ key twice.
5	User Defined Functions	○ Enter Hours, Minutes and AM/PM.
6	Generator System	○ Press ENTER ↓ key.
7	Engine Status	○ Press MENU ↓ key twice.
8	Source History	○ Enter Month—Day—Year.
9	Calibration	○ Press ENTER ↓ key.
10	Remote Control	
11	Programming Mode	

To Enter & Exit a Menu:	To Manually Store Set Points:	Programming Mode:	System Shutdown or System Warning Lamp On:
○ Press RESET MENU key.	○ Select Local programming mode.	○ Enter code to select mode.	○ See display for message.
○ Press MENU → key to scan menus or enter menu number.	○ Press RESET MENU key.	○ Off permits monitoring only.	○ Clear fault, then set the MASTER SWITCH to the OFF/RESET position.
○ Press MENU ↓ key.	○ Press ENTER ↓ key.	○ Local permits adjustment using keypad.	○ Press RESET MENU key.
○ MENU ↓ key vertically scans menu.		○ Remote permits adjustment using remote computer.	
○ MENU → key horizontally scans menu.			
○ Press RESET MENU key to exit menu.			

Lamp Test:	To Stop Programmed Engine Run:	Not In Auto Lamp On:
○ Press RESET MENU key.	○ Press STOP PROG RUN key.	○ To clear, set the MASTER SWITCH in the AUTO position.
○ Press LAMP TEST key.		

# CONTROLLER

## Annunciator Panel

An Alarm Horn and five LED indicators provide local audio/visual indication of system status.

The **ALARM HORN** will sound whenever the selector switch is not in the AUTO position or a fault shutdown has occurred.

The Alarm will also sound along with various warning indications (\*).

Five **INDICATORS** provide visual status of the Generator set.

- **SYSTEM READY** (green)  
Run/Off/Auto switch is in the Auto position and no faults are on the system.
- **NOT IN AUTO** (yellow)  
Run/Off/Auto switch is not in the Auto position.
- **PROGRAMMING MODE** (yellow)  
Local Programming mode. (FLASHING)  
Remote Programming mode. (STEADY)

- **SYSTEM WARNING** (yellow)  
A fault condition of one or more of the following is detected and a shutdown may occur if not corrected:

- CUSTOMER AUXILIARY WARNINGS 1-4. (\*)
- GROUND FAULT DETECTED. (\*)
- GENERATOR SWITCH NOT IN "AUTO".
- EMERGENCY POWER SYSTEM IS SUPPLYING LOAD.
- SPEED SENSOR FAULT. (\*)
- LOAD SHED.
- OVERCURRENT. (\*)
- LOW BATTERY VOLTAGE.
- BATTERY CHARGER FAULT.
- HIGH BATTERY VOLTAGE.
- WEAK BATTERY.
- LOW FUEL. (\*)
- HIGH COOLANT TEMPERATURE.. (\*)
- LOW OIL PRESSURE. (\*)
- LOW COOLANT TEMPERATURE.. (\*)
- COOLANT TEMPERATURE SIGNAL LOSS.
- OIL PRESSURE SIGNAL LOSS.

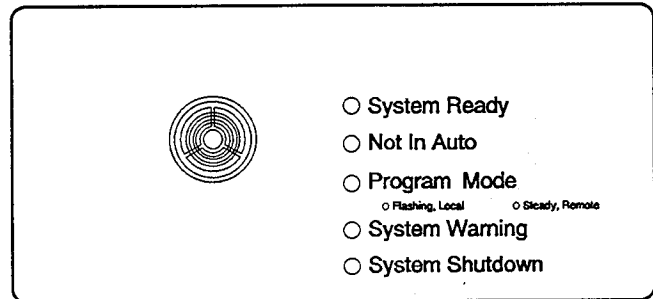

- **SYSTEM SHUTDOWN** (red)  
A shutdown will occur due to one or more of the following faults:

- LOW OIL PRESSURE
- HIGH COOLANT TEMPERATURE
- OVERCRANK
- LOCKED ROTOR
- OVERSPEED
- EMERGENCY STOP
- OVERVOLTAGE
- UNDERVOLTAGE
- UNDERFREQUENCY
- LOW COOLANT LEVEL
- HIGH OIL TEMPERATURE
- CUSTOMER AUXILIARY SHUTDOWNS 1 - 4
- INTERNAL FAULT
- MASTER SWITCH IN OFF/RESET POSITION.

# Decision-Maker™340

# CONTROLLER

## CONTROLLER COMPONENTS.

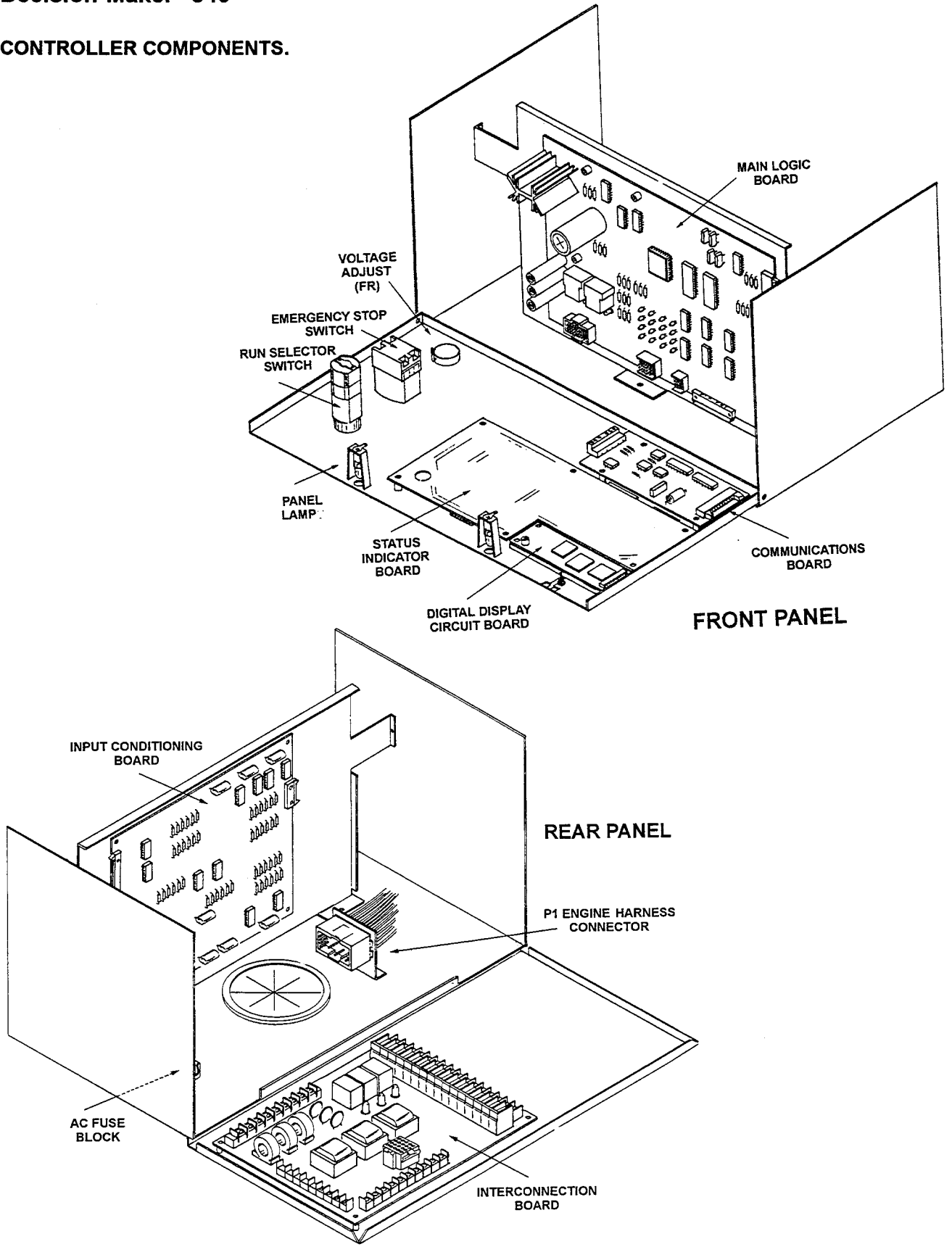

# Decision-Maker™340

# CONTROLLER

## HARNESS AND PLUG CONNECTORS.

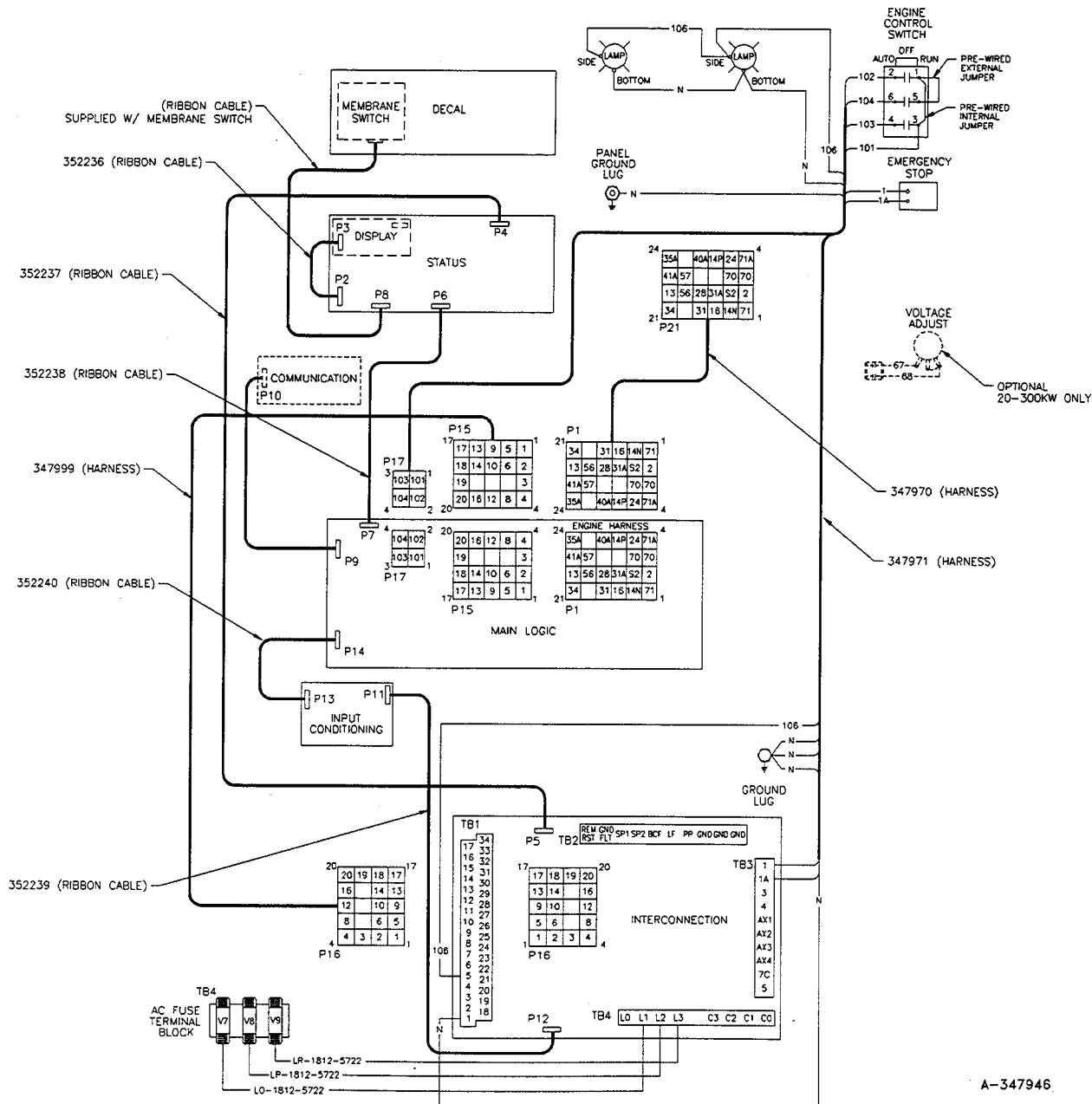

A-347946

# CONTROLLER

## Decision-Maker™340

### INTERCONNECT CIRCUIT BOARD

The Interconnect board receives alternator voltage and current input and provides interconnection to the Conditioner (P12) and Status (P5) panel circuit boards. Hard wiring of accessories and customer connections are made to terminal strips located on the board.

The **TB1** provides relay driver outputs such as engine warning and shutdowns, voltage regulator adjustments and other functions.

The **TB2** provides for input connections such as Prime Power mode, Battery Charger Fault, Low Fuel and Remote Reset and Ground Fault.

The **TB3** provides connections for Remote Start, Emergency Stop, engine gauge senders and Auxiliaries.

The **TB4** is the AC voltage and current input from the Alternator. Three fuses protect the power input circuit.

Output from potential transformers T1, T2, T3 and current transformers CT1, CT2 and CT3 are supplied to the Conditioner board via the P12 ribbon connector.

The P16 plug connector provides interconnection to the Main Logic circuit board.

Relays K2 and K3 are controlled from the Status panel. They provide "up" and "down" voltage control of units with Digital Voltage Regulators. The K1 controls the panel lamps. Diodes provide visual indication when relays are energized.

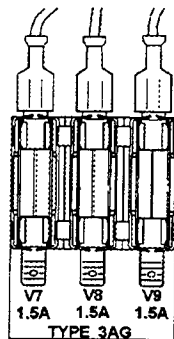
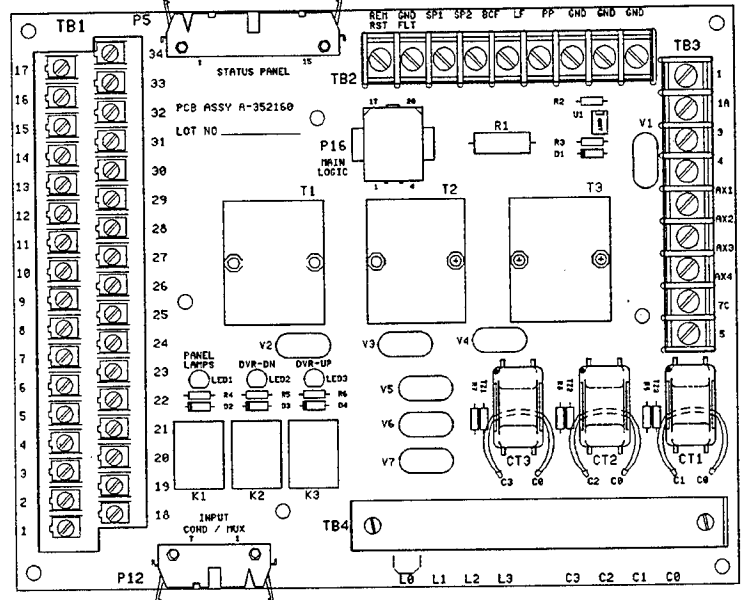

AC FUSE BLOCK

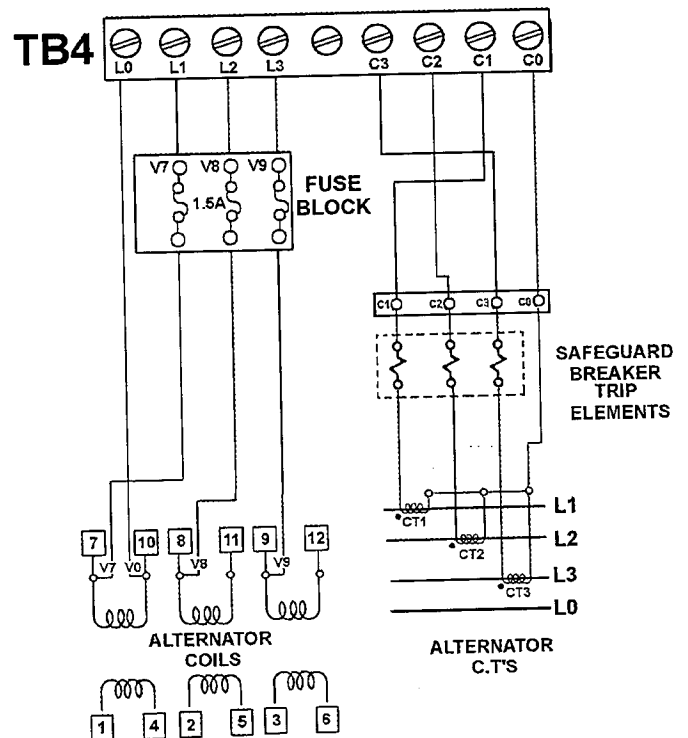

# CONTROLLER

## Decision-Maker™340

### Interconnect Circuit Board TB2 & TB3 TERMINAL STRIP

#### TB2 CUSTOMER CONNECTIONS

- **REM RST (Remote Start)**  
The switch used for remote reset must be a normally open, momentary closed type.
- **GRD FLT (Ground Fault)**  
A ground detected will light the Annunciator System Warning indicator lamp.
- **SP1 / SP2**  
These terminals are not used.
- **BCF (Battery Charger Fault)**  
Contact provided in optional Battery Charger to close on a charger fault.
- **LF (Low Fuel)**  
Ground path provided on closure of optional low fuel level or low fuel pressure switch.
- **PP (Prime Power)**  
The Prime Power switch option prevents battery drain during non-operational periods when battery charging is not available.
- **GRD (Ground)**  
Ground terminals are connected to engine block.

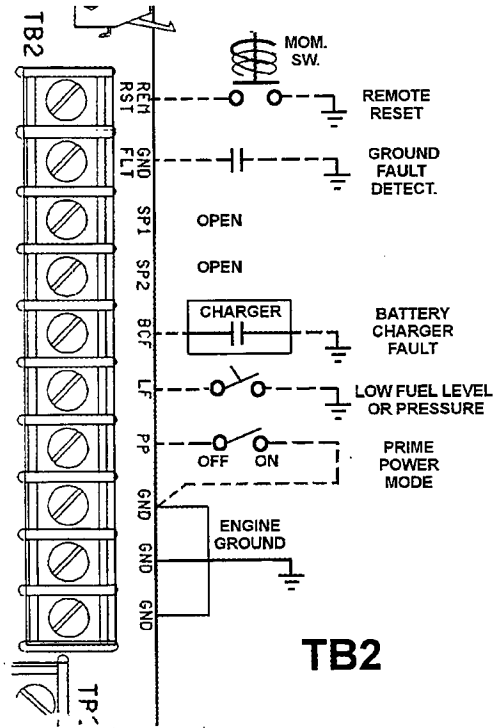

#### TB3 CUSTOMER CONNECTIONS

- **1 - 1A (Emergency Stop)**  
Opening the circuit between 1-1A will cause an immediate engine shutdown.
- **3 - 4 (Remote Start/Stop)**  
Contact closure between 3 - 4 will cause an engine start.
- **Ax-1, 2, 3, 4 (Auxiliary Devices)**  
Customer selected device providing ground contact to terminal will cause Warning indication or Shutdown.
- **7C (Water Temperature Sender)**  
Engine mounted temperature sensor input. (standard)
- **5 (Oil Pressure Sender)**  
Engine mounted oil pressure sensor input. (standard)

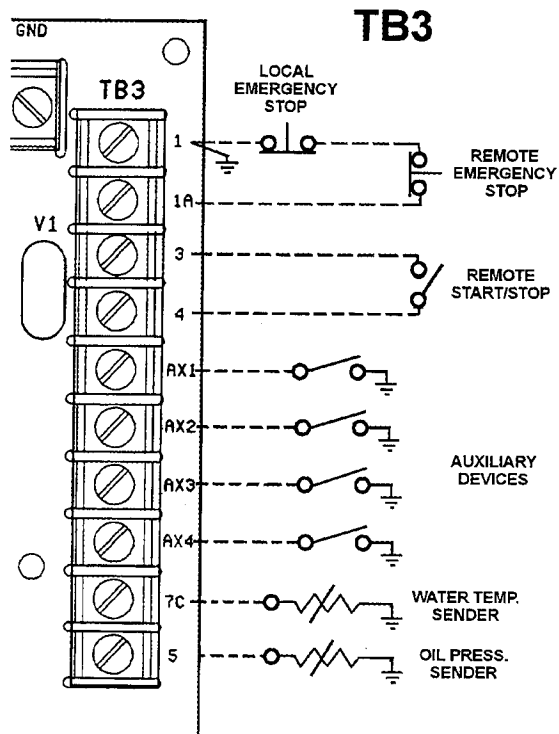

# CONTROLLER

## Decision-Maker™340

### Interconnect Circuit Board TB1 TERMINAL STRIP

The TB1 Terminal Strip provides output signals to drive optional dry contact Relay Kit assemblies.

The terminals are at Grd. potential when the fault occurs and limited to 100 Milliampere load.

The Relay kits are available with 1, 10 or 14 board mounted 12v relays. The relay boards are voltage regulated and will accept either 12 or 24v battery system inputs from B+ accessory power terminals 42A ( 18, 19 and 20).

The accessory Power Circuit is supplied from the F1 fuse on the Main Logic Board.

Terminals designated as RDO- are Relay Driver Outputs and provide additional indications.

The factory default designations for the RDO's are:

- RDO-1 NFPA Common Fault
- RDO-2 Common Fault
- RDO-3 Generataor Running
- RDO-4 Time Delay Engine Cooldown
- RDO-5 Air Damper
- RDO-6 Overvoltage Shutdown
- RDO-7 Low Coollant Level Shutdown
- RDO-8 Emergency Power System Supplying Load.
- RDO-9 Speed Sensor Fault
- RDO-10 High Battery Voltage

Power to the panel lamps and "up/down" control for digital voltage regulators is also provided on the terminal strip.

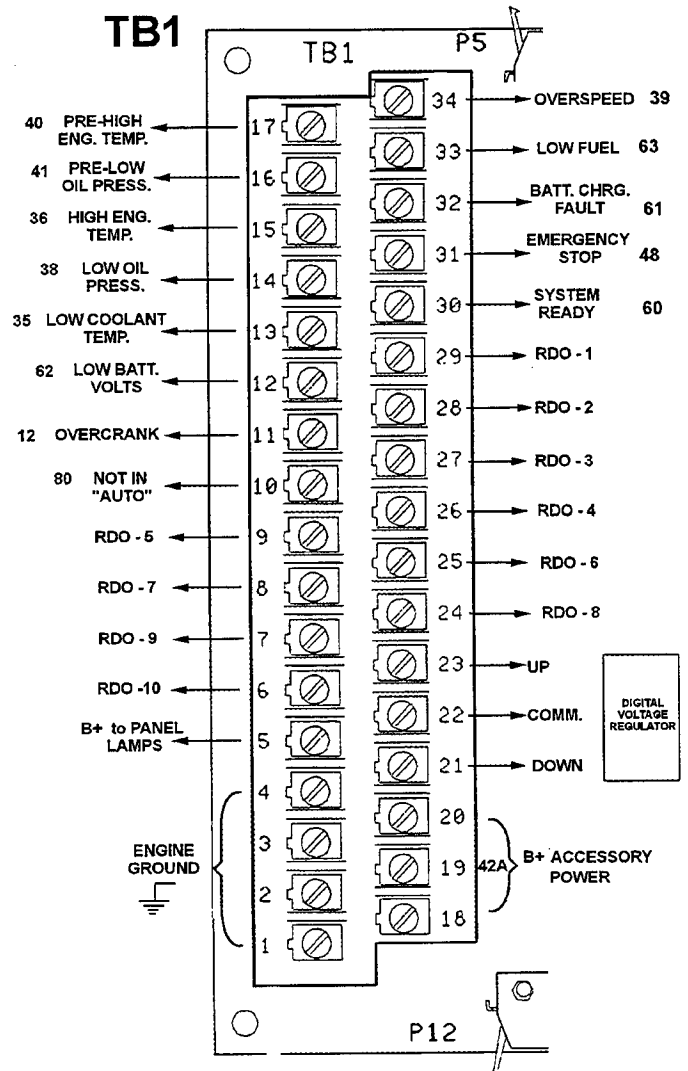

# CONTROLLER

## Decision-Maker™340

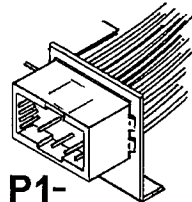
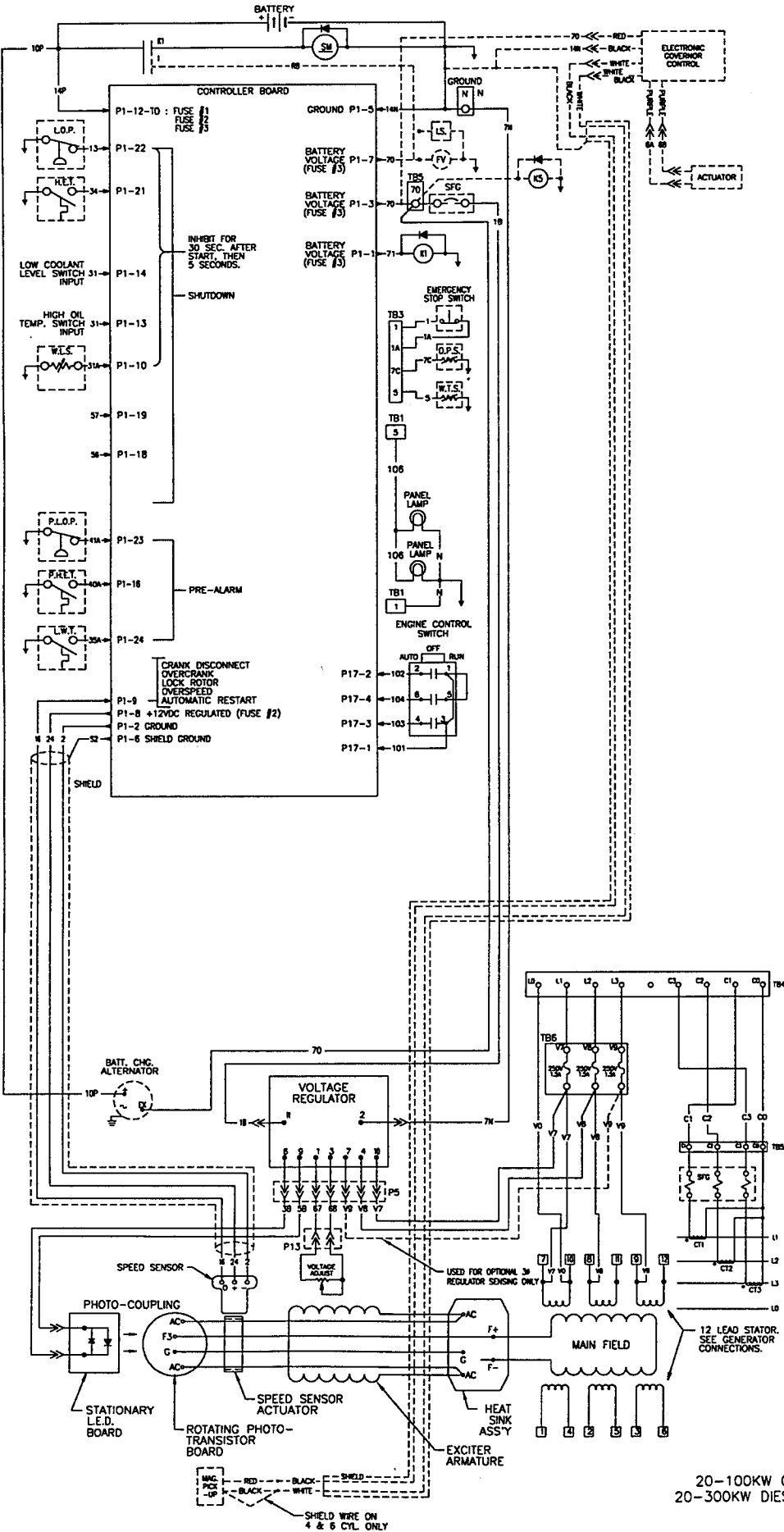

P1-

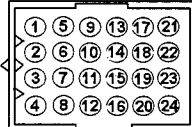

- TB(NUM) - CONTROLLER BOARD TERMINAL STRIP
- TBS - SAFEGUARD BREAKER TERMINAL BLOCK
- SM - STARTER MOTOR
- K1 - STARTER SWITCH
- K4 - AIR DAMPER RELAY
- K5 - GOVERNOR CONTROL RELAY
- FV - FUEL VALVE
- WTS - WATER TEMPERATURE SENDING UNIT
- LWT - LOW WATER TEMPERATURE
- WLS - WATER LEVEL SENSOR
- SFG - SAFEGUARD BREAKER
- LOP - LOW OIL PRESSURE SWITCH
- PLOP - PRE-ALARM LOW OIL PRESSURE
- HET - HIGH ENGINE TEMPERATURE
- PHET - PREALARM HIGH ENGINE TEMPERATURE
- OPS - OIL PRESSURE SENDING UNIT
- CT - CURRENT TRANSFORMER
- IS - IGNITION SYSTEM
- ~ - BATTERY CHARGING ALTERNATOR

20-100KW GAS  
20-300KW DIESEL



# CONTROLLER

## Decision-Maker™340

### Main Logic Circuit Board

The Main Logic Board interfaces the various controller circuit boards by 6 ribbon and harness connectors.

**P14 - Input Conditioner / MUX .** Provides interconnection to the Conditioner Circuit Board via a 24 pin ribbon connector.

**P9 - Remote Communications.** A 10 pin ribbon harness to the optional communications circuit board.

**P7 - Status Panel.** A 20 pin ribbon connector to the Status Panel.

**P17 - Master Sw.** A 4 pin harness connector to the main start control selector switch ( Run - Off/Reset - Auto)

**P15 - Interconnect** A 20 pin plug connection to the Interconnection Circuit Board.

**P1 - Engine Harness** The 24 pin harness connector interfacing the Engine electrical components

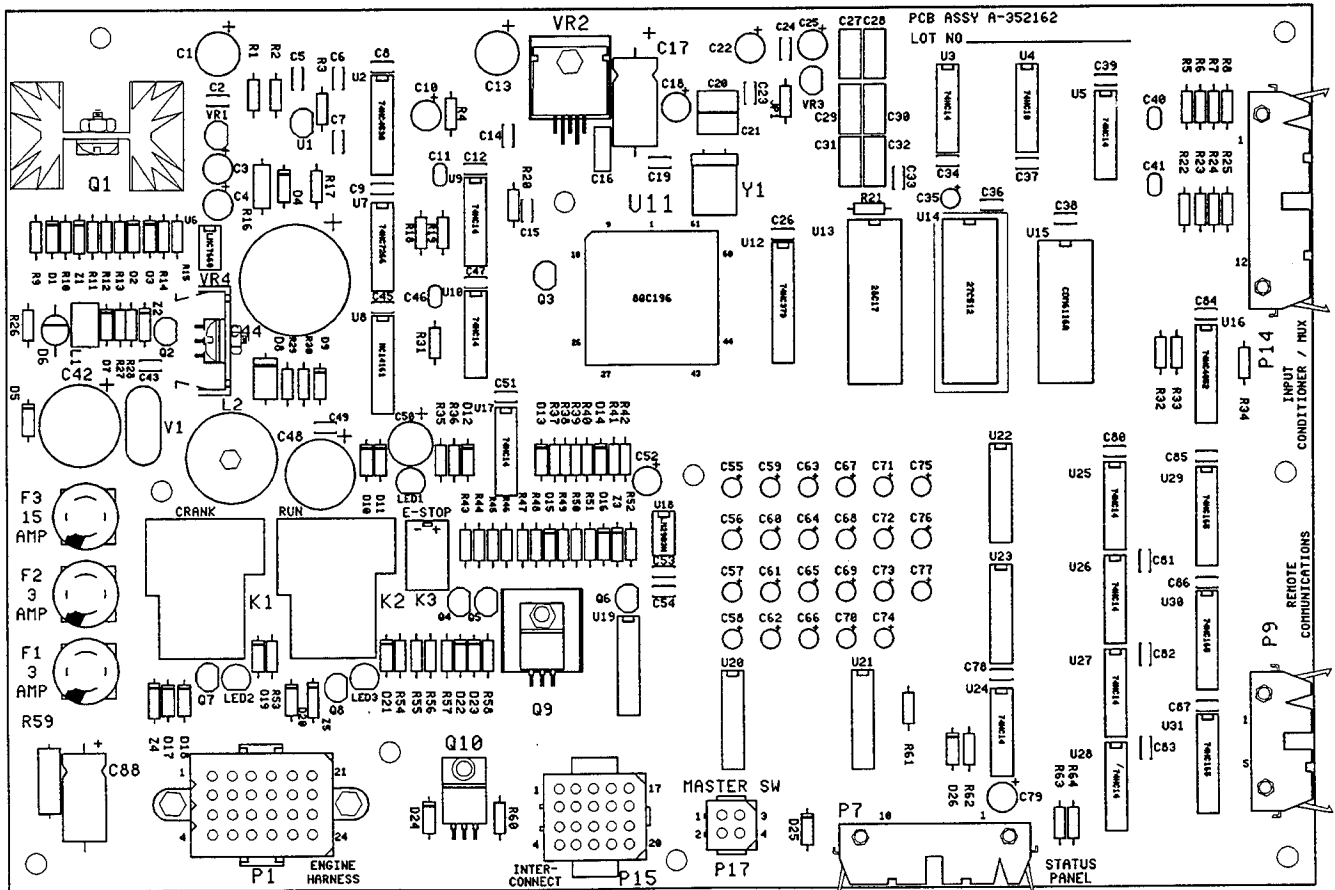

# CONTROLLER

## Decision-Maker™340

### Main Logic Circuit Board

Three relays provide the Engine Start, Run and Stop control functions:

**K1** - Is energized only during the engine crank cycle and provides power to the cranking control solenoid. The **LED2** will light when power is supplied to the K1 relay coil.

**K2** - The K2 relay will be energized during cranking and normal engine running. The relay contacts energize the fuel solenoid and ignition circuits. The contacts also supply battery voltage to the Safeguard terminal strip. **LED3** is energized along with the K2 coil.

**K3** - The K3 relay is energized during engine cranking and normal running. It controls the voltage supply to the K1 and K2 relay coils. The Emergency Stop switches when activated deenergize the K3 relay disrupting power to the K2 engine run relay. **LED1** will light when the K3 relay is energized.

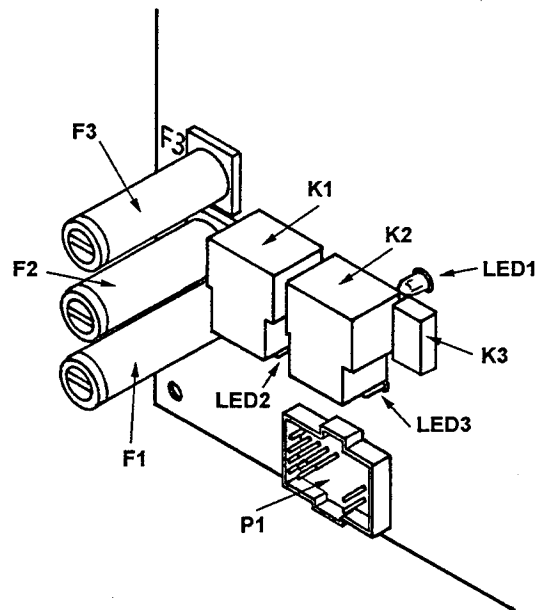

Three fuses mounted to the board protect the DC circuits of the controller:

**F1** - provides a 3A protective circuit to terminal 42A which feeds the customer connected options.

**F2** - A 3A fuse supplies a 12v. regulator circuit. K1, K2 and K3 control relay coils are powered from this circuit.

**F3** - The F3 fuse is rated at 15 amps and protects the engine control circuit.

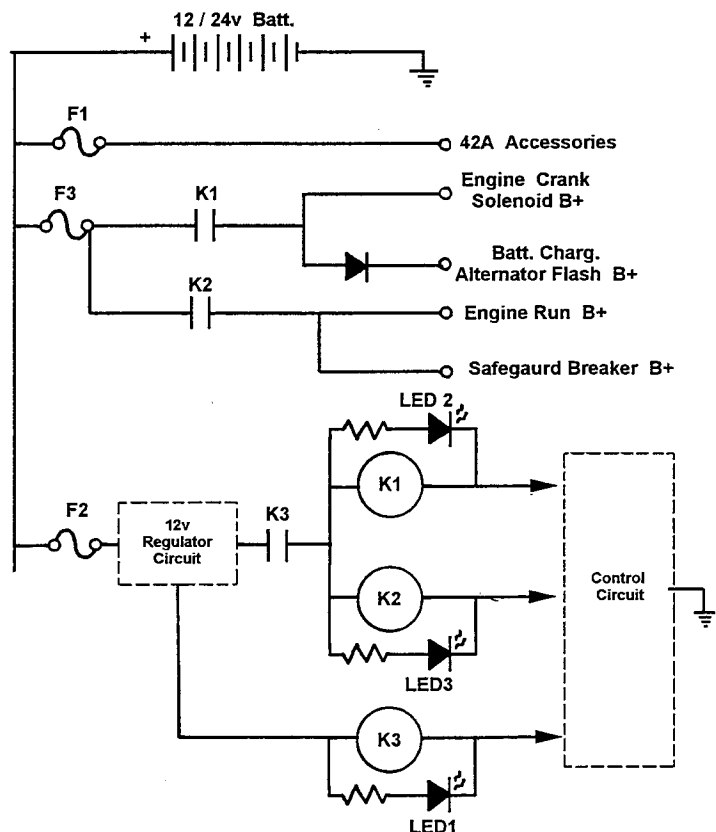

# CONTROLLER

## Decision-Maker™340

### Input Conditioning Board

The basic function of the Conditioning board is to convert Generator line to line and line to neutral voltage and current as well as Engine coolant temperature and Oil pressure to a 0 - 5 volt DC signal. This signal is then supplied to the Main Logic board.

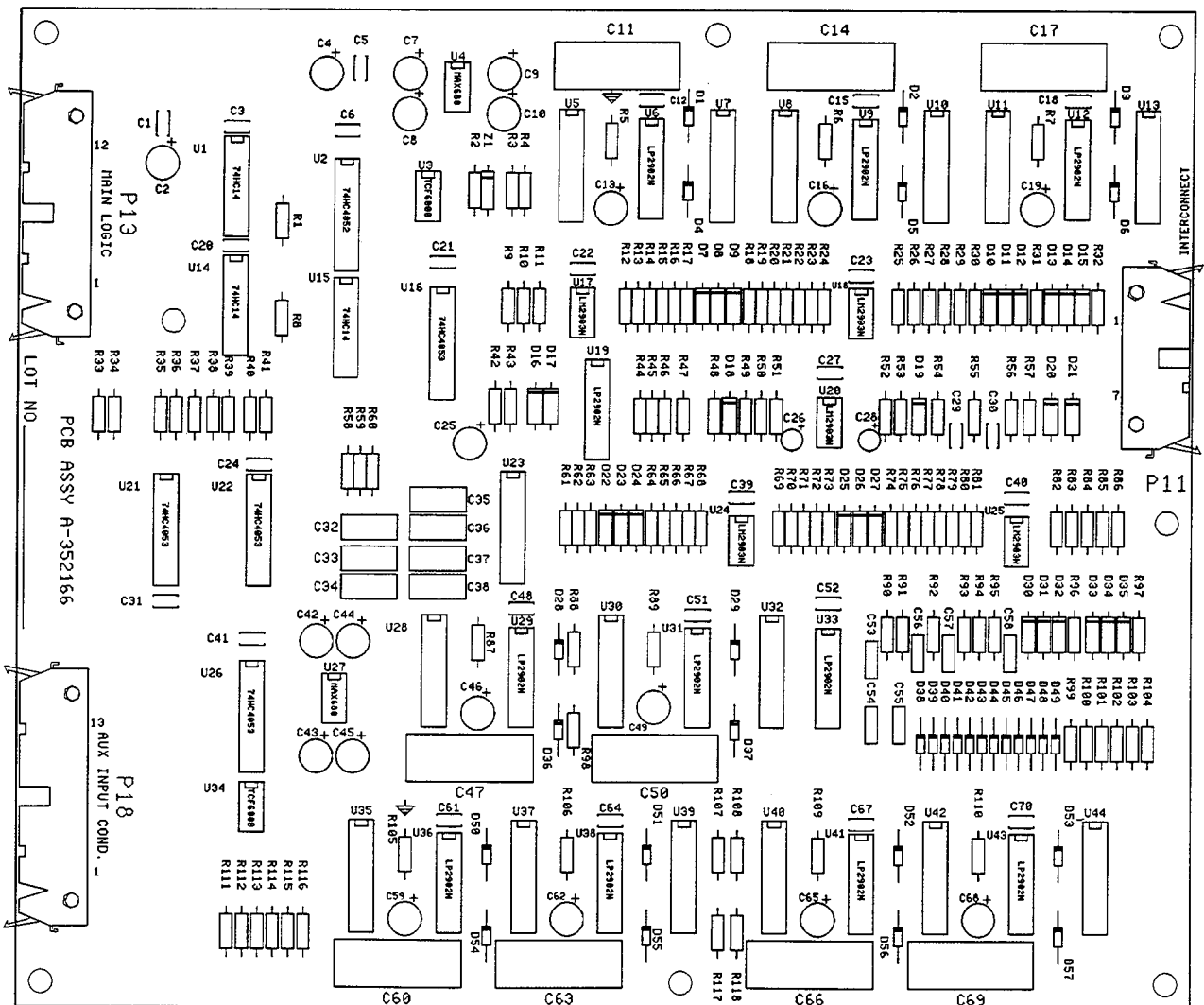

# CONTROLLER

## Decision-Maker™340

### Status Panel - Display Board

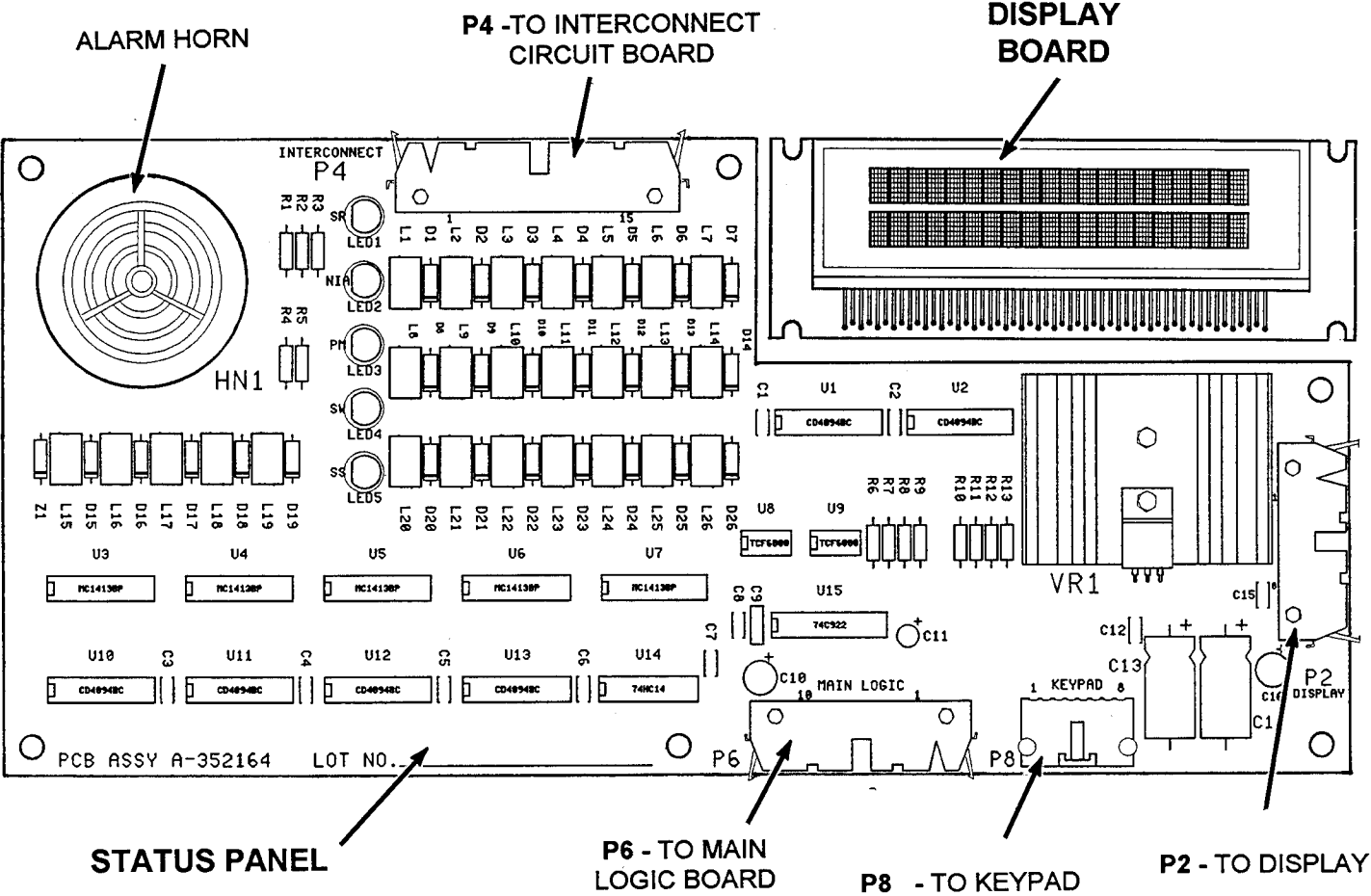

# CONTROLLER

## Decision-Maker™340

### Communications Board (Optional)

If the Generator set is to be monitored or programmed from a personal computer either locally or over telephone lines an optional communications board must be installed.

Two options are offered. The selection depends on the distance between the Generator mounted controller and the PC or receiving motem.

A RS232 board is installed for distances up to 50 ft. For distances up to 4000 ft. or when multiple units are connected in a network a RS485 board is used.

A RS232/ RS485 Converter is also required when RS485 boards are installed.

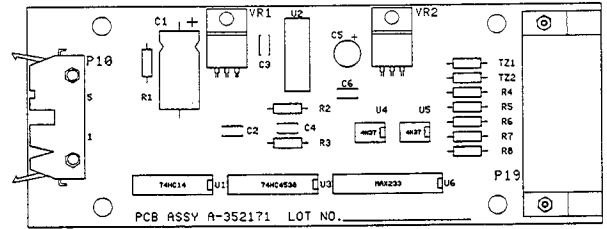

**Communications Board (RS232)**

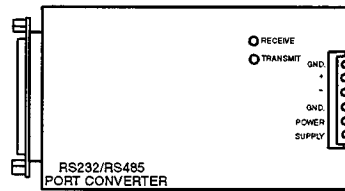

**RS232/RS485  
Converter**

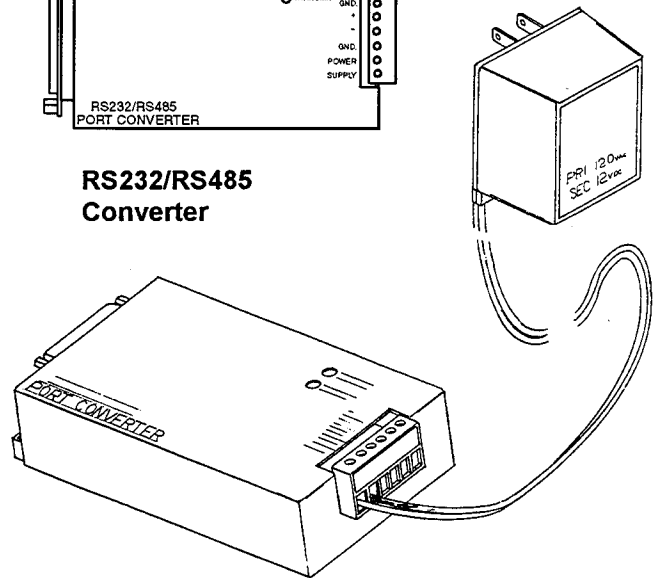

# CONTROLLER

## Decision-Maker™340

Communications Board  
RS232 - RS485

### LOCAL SINGLE CONNECTION

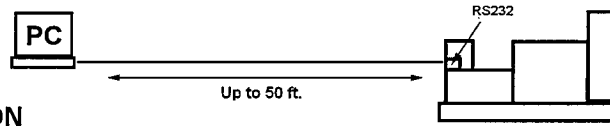

### LOCAL AREA NETWORK

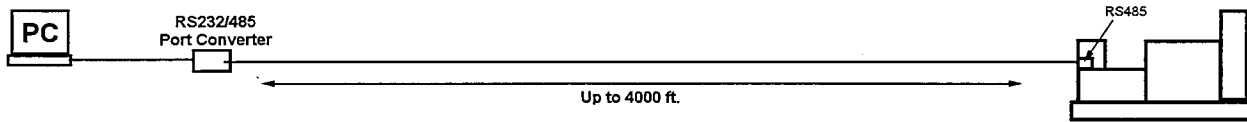

### REMOTE SINGLE CONNECTION



### REMOTE AREA NETWORK

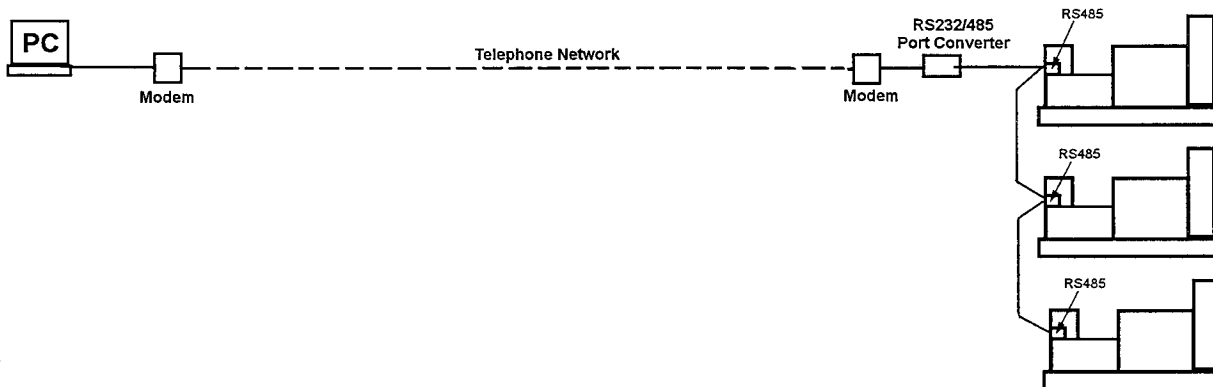

**DEC 3  
OVERVOLTAGE KIT (Optional)**

The circuit board monitors the generator voltage (V7 - V0) at the panel frequency meter and will initiate an engine shutdown if the voltage exceeds a preselected level of 140 or 160 volts for longer than 2 seconds.

The voltage trip must be selected per the generator voltage connection and can be set at either 140 or 160 volts by the J1 jumper.

Wye connected generators when operating at 277/480v or 139/240v require the (jumper) 160 volt trip setting.

Generator connections providing 110 - 120 volts at sensing terminals V7 - V0 will require removal of the jumper, initiating a shutdown at 140 volts.

Voltages are +/- 5v and the 2 second trip time is typical.

The circuit will supply a battery voltage output signal from terminal 30 to the Microprocessor circuit board (P2-2) when triggered. Lead 30 is provided in all DEC 3 controllers and is located in the meter harness.

The kit is adaptable to both 12v and 24v battery systems. **The R2 resistor must be removed for 24 volt operation.**

An Overvoltage shutdown condition will also energize the LED on the board as well as the Auxiliary indicator and alarm horn on the controller Status Panel.

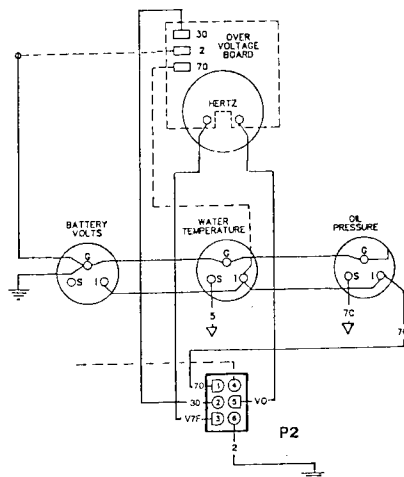
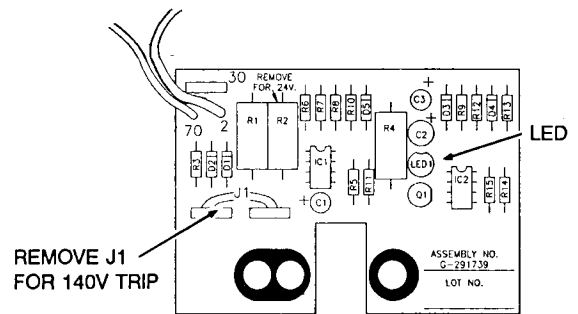
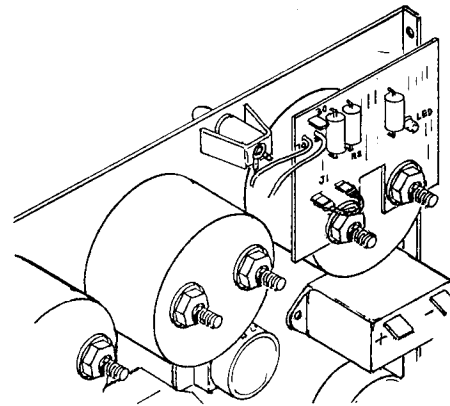

60HZ. - 120/208V. OR 139/240V.  
3 PH. 4 WIRE LOW WYE  
50HZ. - 120/208V. OR 110/190V.  
3 PH. 4 WIRE LOW WYE

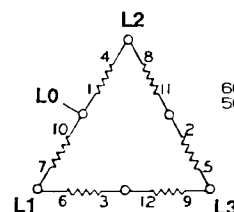
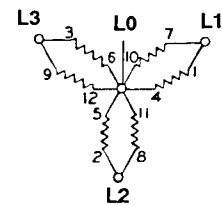

60HZ. - 120/240V. - 3 PH. 4 WIRE DELTA  
50HZ. - 110/220V. - 3 PH. 4 WIRE DELTA





## ACCESSORIES

### REMOTE EMERGENCY STOP SWITCH

Optional (break glass type)

The yellow Break Glass type switch allows the customer to stop the generator set from a remote location if required.

An actuator lever must be pulled down with sufficient force to break a glass rod and trip a toggle switch.

The generator set can not be restarted until both the remote switch and local control switch on the controller status panel are reset. Engine air damper valves must also be reset if equipped.

Once pulled the station switch cannot be reset without opening the cover.

The normally closed switches can be series connected for multiple stations and must be connected in series with the local emergency stop switch if one is installed. (TB1, 1-1A)

#### To Reset:

Turn the locking screw counter-clockwise and lower the hinged cover.

Move the toggle down to the "normal" position. (closed)

Raise the "lift" tab and insert glass rod through holder in front. Close cover.

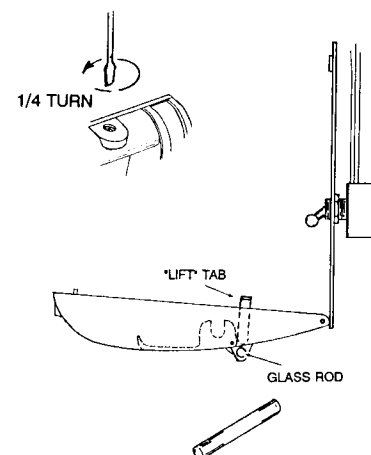
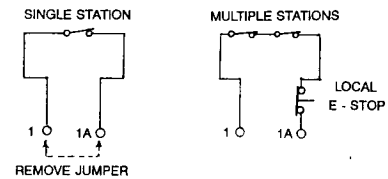
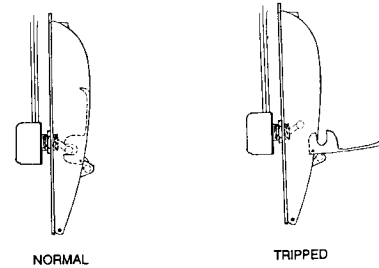
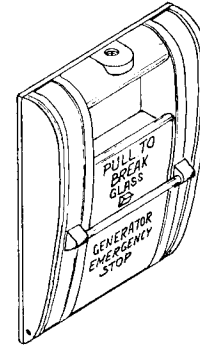



## ACCESSORIES

### DEC 3+ CUSTOMER CONNECTION TERMINAL STRIP (option)

This kit provides a 5 foot, 23 lead wiring harness and 23 terminal barrier strip.

The terminal strip parallels the customer connection portion of the terminal strip on the main logic circuit board. It is recommended when solid conductor wiring is used.

It provides for ease of wiring and service of optional components requiring numerous conductors such as a 10 Relay Dry Contact kit or Remote Decision Monitor.

The strip is installed in the Generator enclosure and eliminates the need for customer/installer entry into the controller cabinet.

Connections for the Emergency Stop option are not provided on this strip. Emergency Stop must be connected to the TB1 terminals on the Decision Maker circuit board.(1 - 1A)

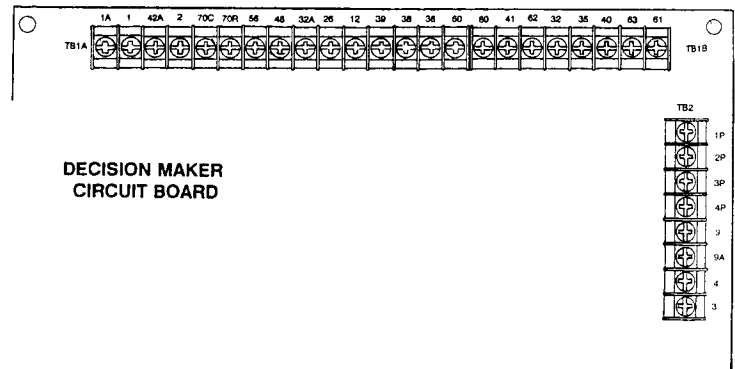
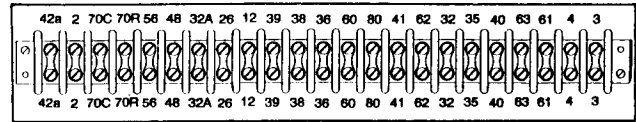

- 42A- BATTERY (+) VOLTAGE
- 2 - GROUND (-)
- 70C- ENGINE COOL DOWN
- 70R- ENGINE RUN
- 56 - AIR DAMPER INDICATOR
- 48 - EMERGENCY STOP INDICATOR
- 32A- COMMON FAULT (2)
- 26 - AUXILIARY INDICATOR
- 12 - OVERCRANK INDICATOR
- 39 - OVERSPEED INDICATOR
- 38 - LOW OIL PRESS. INDICATOR
- 36 - HIGH ENGINE TEMP INDICATOR
- 60 - SYSTEM READY INDICATOR
- 80 - NOT IN AUTO INDICATOR
- 41 - PRE-ALARM LOW OIL PRESS. INDICATOR
- 62 - LOW BATTERY VOLTS (ACTIVE LOW)
- 32 - COMMON FAULT (1)
- 35 - LOW WATER TEMPERATURE
- 40 - PRE-ALARM HI ENG.TEMP. INDICATOR
- 63 - LOW FUEL (ACTIVE ONLY)
- 61 - BATT. CHARGER FAULT (ACTIVE LOW)
- 4 - REMOTE START (ACTIVE LOW)
- 3 - REMOTE START (GROUND)

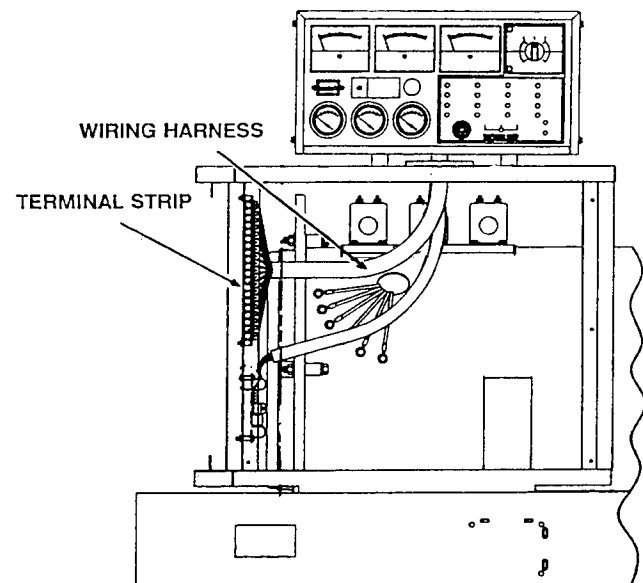



# ACCESSORIES

## AUDIO/VISUAL ALARM KIT (Option)

The Audio/Visual alarm provides both a horn alarm and a red visual indicator to warn personnel at remote work stations of a generator fault or shut down. The Alarm can be silenced with the panel switch. The indicator lamp will remain lit until the fault is corrected and the system is reset.

The panel is designed to be installed in a standard 4" square electrical box and requires a three conductor run of 18 or 20 ga. wire. Connection is made to the generator main controller circuit board terminal strip TB1 or customer connection terminal strip if installed.

The panel can be wired to indicate a specific single fault or to the common fault terminal.

Terminal 42A (+) provides system battery voltage to the panel. (12 or 24vdc). The black panel lead must connect to the control system ground (-) terminal 2. If a (-) signal is sensed at the input terminal (white) an alarm will be triggered.

Connection of the white sensing lead to Common Fault terminal 32 on Dec 3 or Dec 3+ control boards will provide an alarm on any of the following:

- PRE-HIGH ENG. TEMP. - LOW WATER TEMP.
- PRE-LOW OIL PRESS. - LOW FUEL
- LOW OIL PRESSURE. - OVERCRANK
- HIGH ENGINE TEMP. - OVERSPEED
- AIR DAMPER - AUXILIARY

Connection to Common Fault terminal 32A on Dec 3+ boards will provide an alarm on any of the following:

- AUXILIARY. - HIGH ENG. TEMP.
- OVERSPEED. - LOW OIL PRESS.
- EMERGENCY STOP

If custom selection of monitored faults is desired the Common Fault Relay Kit can be incorporated.

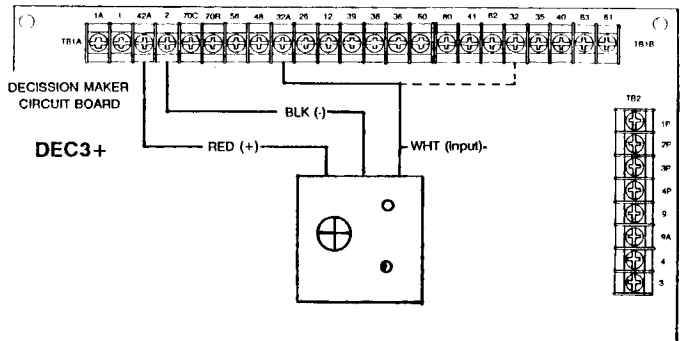
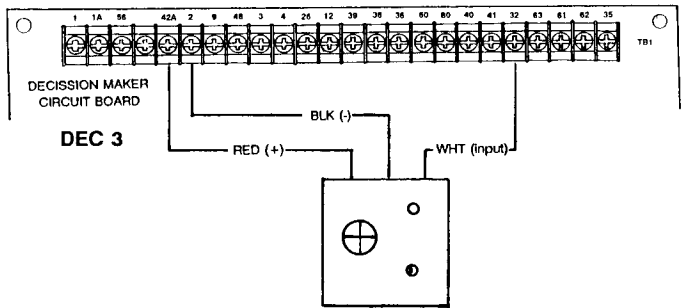
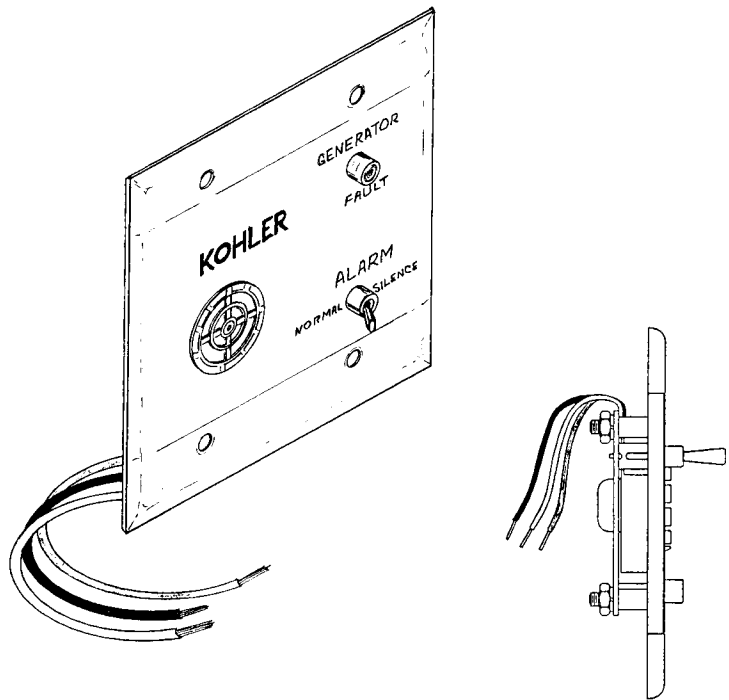



# ACCESSORIES

## COMMON FAULT RELAY (Optional) DEC 3+

This board provides a dry set of contacts to activate customer supplied remote alarms, shunt trips, indicators or other accessory devices if any one of various preselected fault conditions occur.

The relay will energize if the generator set is running and an input signal common to the generator set ground potential (-) is directed to the K1 terminal. Once energized the relay will remain latched until the system is reset by the main controller switch.

A common signal will be provided from terminal 32A if any of the following five faults occur:

- 36 HIGH ENGINE TEMP.**
- 38 LOW OIL PRESSURE**
- 39 OVERSPEED**
- 26 AUXILLIARY IND.**
- 48 EMERGENCY STOP**

A common signal will be provided from terminal 32 if any of the following occur.

- 36 HIGH ENGINE TEMP**
- 38 LOW OIL PRESSURE**
- 39 OVERSPEED**
- 26 AUXILLIARY**
- 12 OVERCRANK**
- 35 LOW WATER TEMP.**
- 40 PRE-HIGH ENG. TEMP.**
- 41 PRE-LOW OIL PRESSURE**
- 56 AIR DAMPER**

Any of the above can be selected as a single monitored condition if desired.

Maximum resistive loads up to 10A @ 120vac can be applied to the output terminals. The relay contacts are gold flashed to allow use of low current draw devices. (.01A @ 28vdc min.)

Input power supply 42A and 2 is to the relay coil only and not intended to power customer supplied indicator loads.

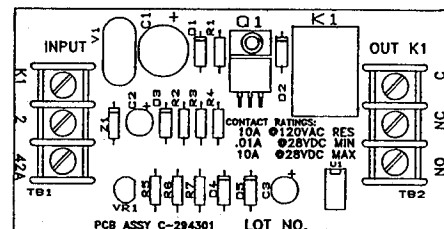
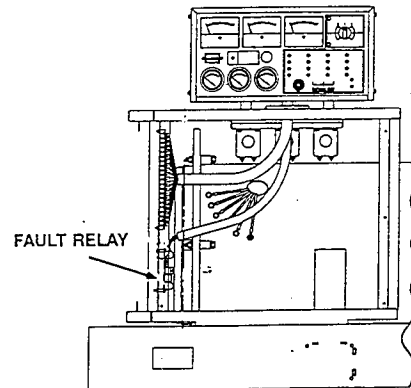
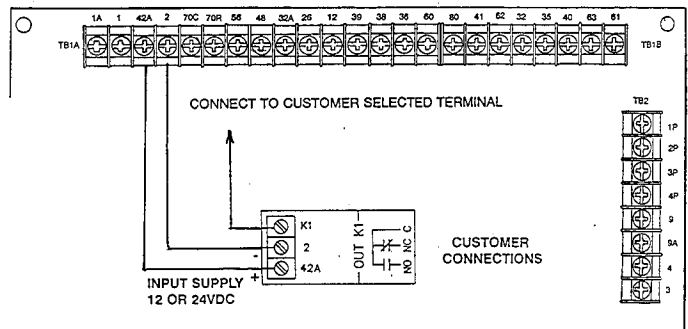
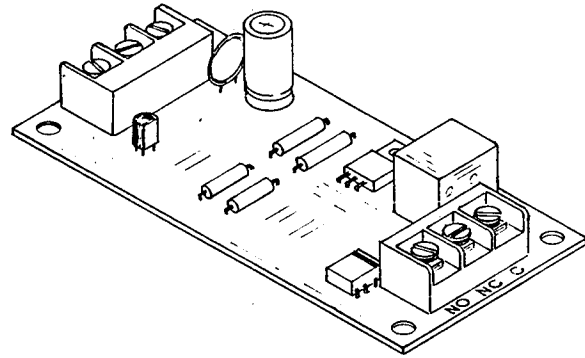

## ACCESSORIES

### COMMON FAULT RELAY (Optional) DEC 3

This board provides a dry set of contacts to activate customer supplied remote alarms, shunt trips, indicators or other accessory devices if any one of various preselected fault conditions occur. The indicator cannot however identify the fault.

The relay will energize if the generator set is running and an input signal common to the generator set ground potential (-) is directed to the K1 terminal. Once energized the relay will remain latched until the system is reset by the main controller switch.

The harness provided allows up to 5 inputs from the Decision-Maker Controller. One or all may be connected to K1.

Diodes provided in the harness are required to prevent back feeding of indicators on the local status or remote indicator panels.

Faults most commonly selected are:

- 36 - HIGH ENGINE TEMP
- 38 - LOW OIL PRESSURE
- 39 - OVERSPEED
- 26 - AUXILIARY IND.
- 48 - EMERGENCY STOP

Maximum resistive loads up to 10A @ 120vac can be applied to the output terminals. The relay contacts are gold flashed to allow use of low current draw devices. (.01A @ 28vdc min.)

The board can be tested by grounding the shutdown device while the generator set is running.

### TEST PROCEDURE

1. Connect ohmmeter across NO. and C.
2. Ground safety device while gen. set is running.
3. Observe ohmmeter during shutdown, contacts should close.

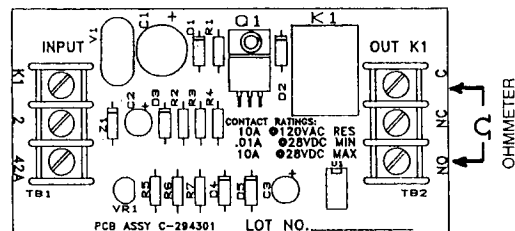
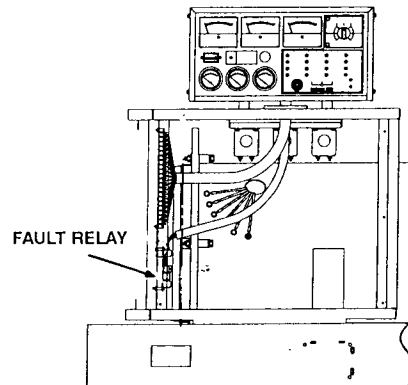
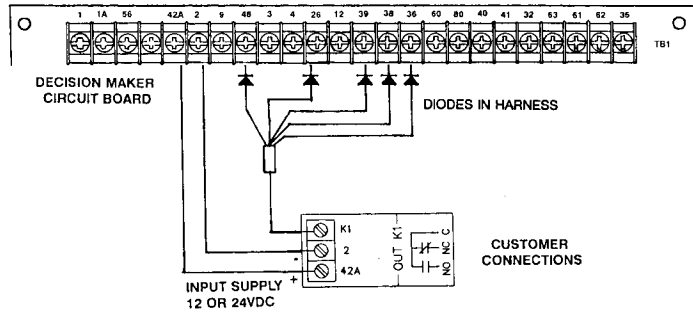
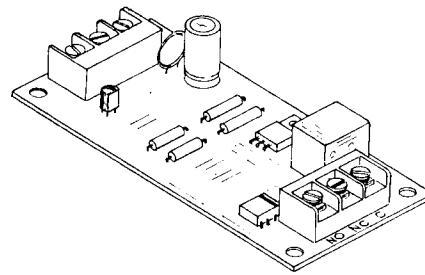



## ACCESSORIES

### DRY CONTACT KIT (Optional) 1 RELAY

The Single-Relay Dry Contact kit provides one set of SPDT contacts to trigger customer provided warning devices when one particular fault selected by the customer occurs. This allows monitoring of the system from a location remote from the generator set. Any function fault (from TB1 terminal strip) can be connected to drive the relay.

The relay on the circuit board will energize if the generator set is running and an input signal common to the generator set ground potential (-) is directed to the K1 terminal. Once energized the relay will remain latched until the system is reset by the main controller switch.

Overspeed, overcrank, high engine temperature, low oil pressure, or low water temperature are typical conditions selected for monitoring.

Lamps, audible alarms, or other devices may be connected to the normally open or closed contacts of the relay. Customer provided accessories require their own electrical source and must not exceed the relay contact ratings.

Maximum resistive loads up to 10A @ 120vac can be applied to the output terminals. The contacts are gold flashed to allow use of low current draw devices (.01A @ 28vdc min.)

The kit should be mounted on the generator set. An enclosure box and 26' harness is provided.

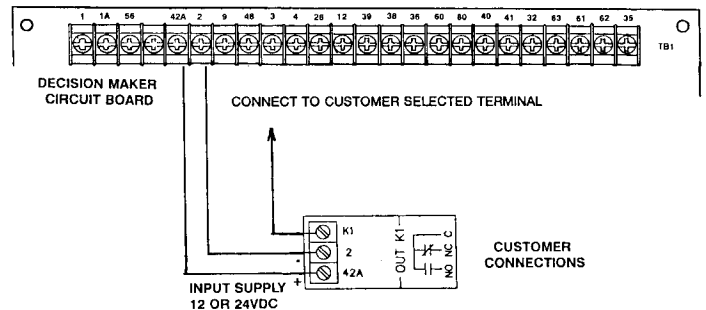
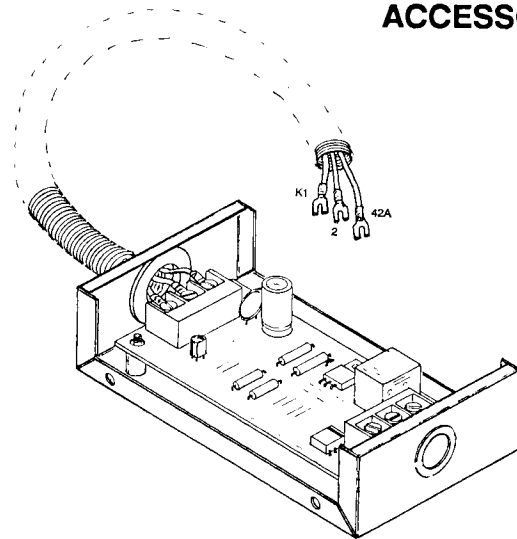
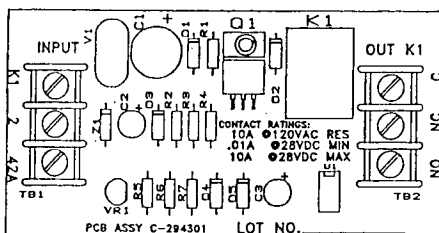

### TERMINAL SELECTION

- (48) EMERGENCY STOP
- \* - (56) AIR DAMPER
- \* - (26) AUXILIARY
- \* - (12) OVERCRANK
- \* - (39) OVERSPEED
- \* - (38) LOW OIL PRESSURE
- \* - (36) HIGH ENG. TEMP.
- (60) SYSTEM READY -
- (80) SW. NOT IN 'AUTO'
- \* - (40) PRE-HIGH ENG. TEMP.
- \* - (41) PRE-LOW OIL PRESSURE
- \* - (35) LOW WATER TEMP.
- (32) COMMON FAULT

WHEN CONNECTED TO COMMON FAULT TERMINAL 32, RELAY WILL ENERGIZE WHEN CONDITIONS INDICATED (\*) OCCUR.

- (61) BATT. CHG. FAULT
- (62) LOW BATT. VOLTS
- (63) LOW FUEL

REQUIRE EXTERNAL CONTACTS CONNECTED TO TERMINALS TO FUNCTION.



# ACCESSORIES

## DRY CONTACT KIT (Optional) 10 RELAY

Up to ten generator set conditions can be individually monitored and faults identified from a remote location.

A relay coil will be energized when the corresponding engine or generator sensing device or switch monitored by the Microprocessor Control board is activated.

Senders are not included with dry contact kits and must be available for the relays to function.

Each relay provides one set of SPDT contacts for field connection of customer supplied indicators or alarms. Contacts are rated for a maximum resistive load of 10A @ 120vac. They are gold flashed to allow use of low current draw devices. (.01A @ 28vdc Min.)

The relays are controlled and energized from the TB1 terminal strip of the micro processor circuit board. A total of three dry contact kits can be driven by the output terminals. It is highly recommended that a customer connection kit (terminal strip) be used and all connections terminate in the generator enclosure box. The relay assembly box should be located at the generator.

Ten conditions typically selected are:

- K1 OVERSPEED (39)
- K2 OVERCRANK (12)
- K3 HIGH ENGINE TEMP (36)
- K4 LOW OIL PRESS (38)
- K5 LOW WATER TEMP (35)
- K6 AUXILIARY FAULT (26)
- K7 AIR DAMPER (56)
- K8 ANTICIPATORY HI ENGINE TEMP (40)
- K9 ANTICIPATORY LOW OIL PRESS (41)
- K10 EMERGENCY STOP (48)

Terminals 42A (+), and 2 (-) are battery supply voltage for driving the relay coils of the dry contact kit and not to be used as a supply source for the alarm devices.

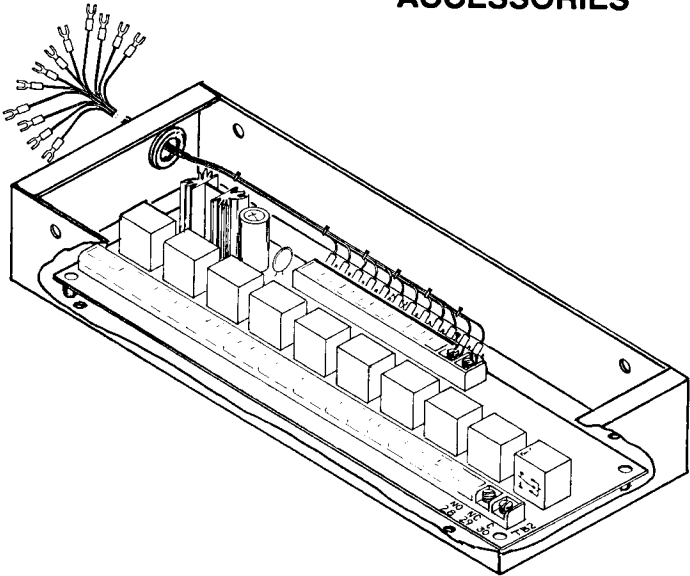

DECISION MAKER  
CIRCUIT BOARD

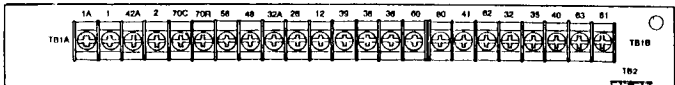

CONNECTION KIT  
TERMINAL STRIP

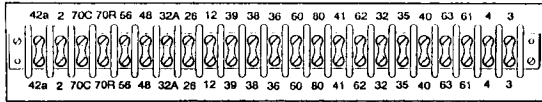

DRY RELAY  
CONTACT KIT

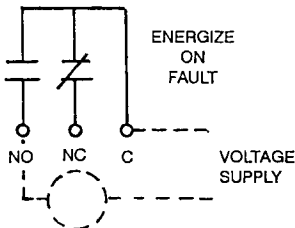
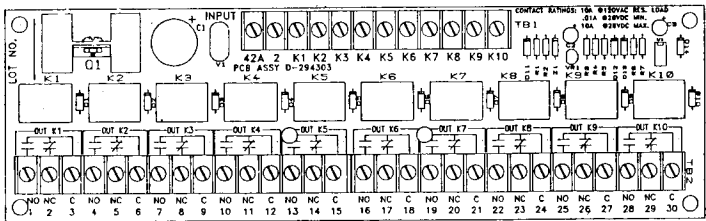

INDICATOR OR ALARM

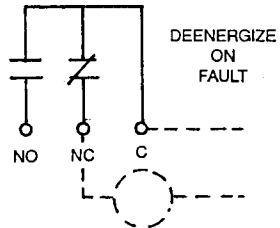



## ACCESSORIES

### DRY CONTACT KIT (Optional) 14 RELAY

Dry contact kits provide an isolated interconnection between the generator set controller and optional devices as the Decision Monitor annunciator. Up to fourteen conditions can be specifically identified with this kit.

A relay coil will be energized when the corresponding engine or generator sensing device or switch monitored by the Microprocessor Control board is activated.

Each relay provides one set of SPST contacts for field connection of customer supplied indicators or alarms. Contacts are rated for a maximum resistive load of 10A @ 120vac. They are gold flashed to allow use of low current draw devices. (.01A @ 28vdc Min.)

The relays are controlled and energized from the TB1 terminal strip of the micro processor circuit board. A total of three dry contact kits can be driven by the output terminals. It is highly recommended that a customer connection kit (terminal strip) be used and all connections terminate in the generator enclosure box. The relay assembly box should be located at the generator.

The input harness is connected to provide monitoring of the following conditions:

- K1 OVERSPEED (39)
- K2 OVERCRANK (12)
- K3 HIGH ENGINE TEMP (36)
- K4 LOW OIL PRESS (38)
- K5 AUXILIARY FAULT (26)
- K6 SYSTEM READY (60)
- K7 NOT IN AUTO (80)
- K8 PRE-LOW OIL PRESS (41)
- K9 EMERGENCY STOP (48)
- K10 BATT. CHARGER FAULT (61)
- K11 LOW BATT. VOLTS (62)
- K12 LOW FUEL (63)
- K13 LOW WATER TEMP (35)
- K14 PRE-HIGH ENG. TEMP. (40)

Terminals 42A (+), and 2 (-) are battery voltage for driving the relay coils of the dry contact kit and not to be used to power output devices. A 10 amp fuse assembly is included to supply battery voltage to remote annunciators connected to the relay outputs.

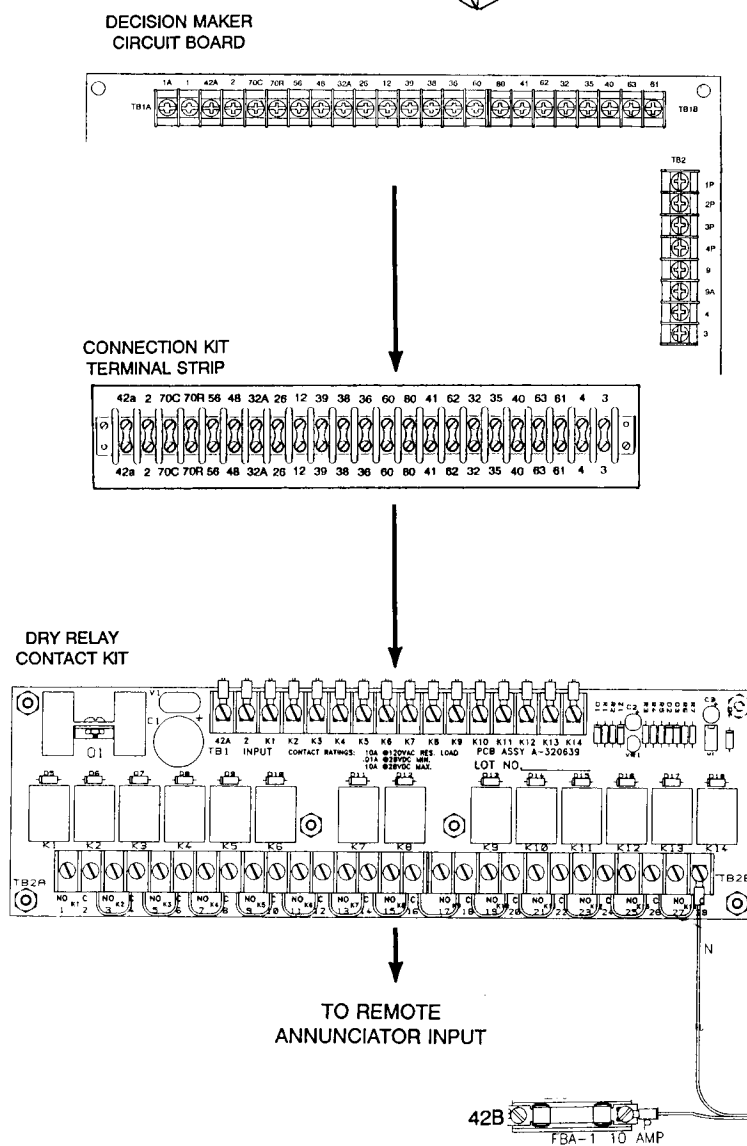
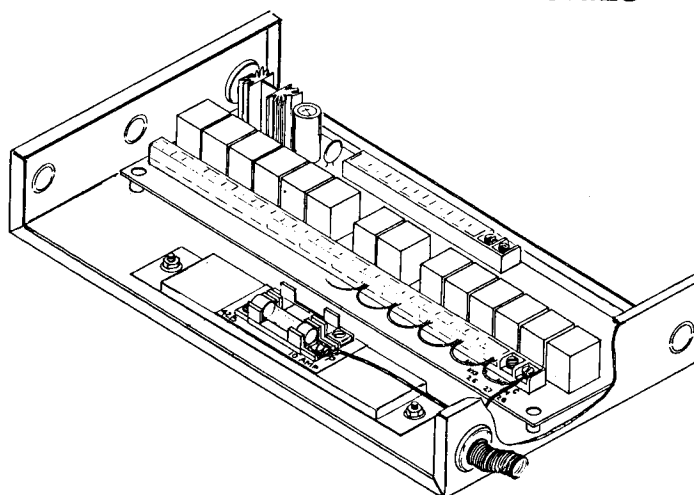

RELAY DRY CONTACT ASSEMBLY

INPUTS FROM DECISION MAKER CIRCUIT BOARD

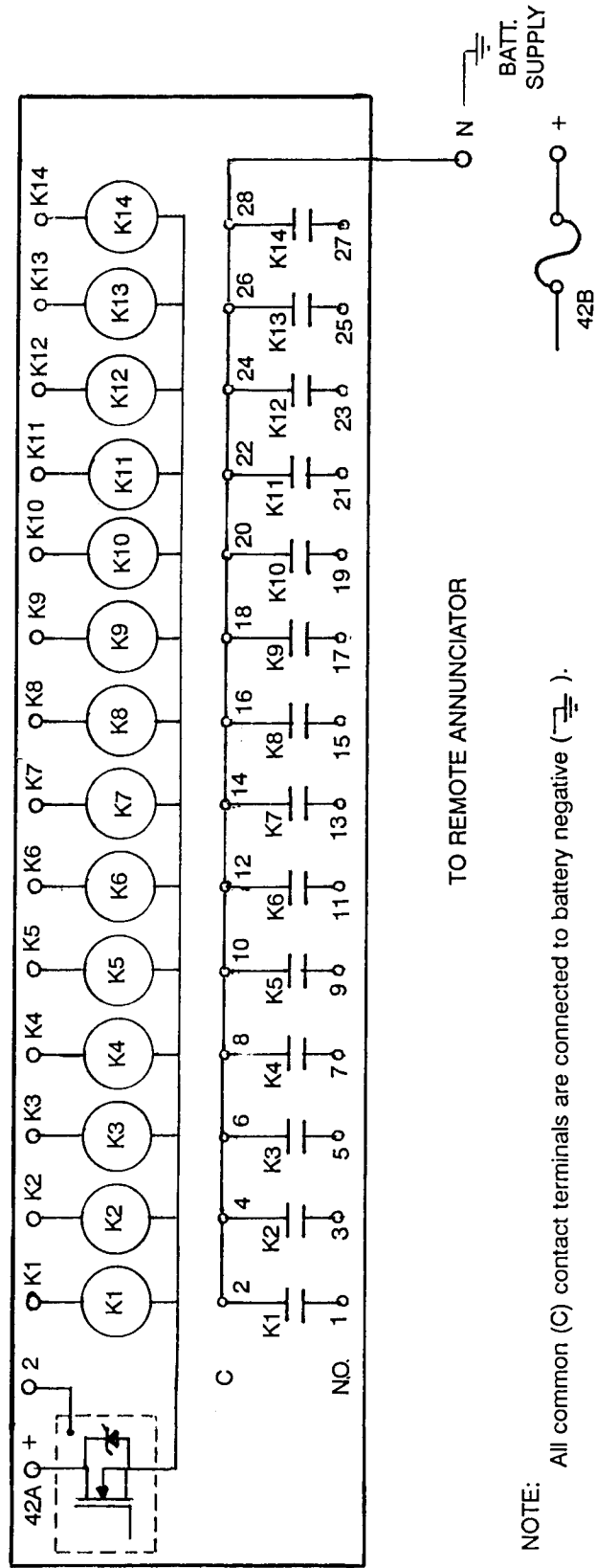

### REMOTE ANNUNCIATOR PANEL (optional) 16 LIGHT

The remote annunciator or "Decision Monitor" allows monitoring numerous conditions of the generator system from a remote location.

If a generator alarm condition arises the remote annunciator will provide visual and audible signals to alert area personnel.

A lamp test switch and switch to silence the alarm are provided on the panel. The alarm horn can only be silenced with the generator master switch in the AUTO position.

The Annunciator contains 16 LED indicators; 4 yellow (pre-alarm and power sources), 1 green (system ready), and 11 red.

The following are conditions available for monitoring. (\* visual only)

- **PREALARM HIGH ENGINE TEMP. (40)**  
Lamp will light if engine coolant temperature approaches shutdown range. (requires sender)
- **PREALARM LOW OIL PRESSURE. (41)**  
Lamp will light if engine oil pressure approaches shutdown range. (requires sender)
- **LOW WATER TEMPERATURE. (35)**  
Lamp will light if optional block heater malfunctions or coolant is below 60°F (16°C).
- **LOW FUEL. (63)**  
Lamp will light if fuel level drops to a preselected level. (requires sender)
- **HIGH ENGINE TEMPERATURE (36)**  
Lamp will light if generator set has shut down due to a high engine coolant temperature.
- **LOW OIL PRESSURE (38)**  
Lamp lights if generator set has shut down due to low engine oil pressure.
- **EMERGENCY STOP (48) \***  
Lamp lights if generator set has been stopped by an emergency stop switch.

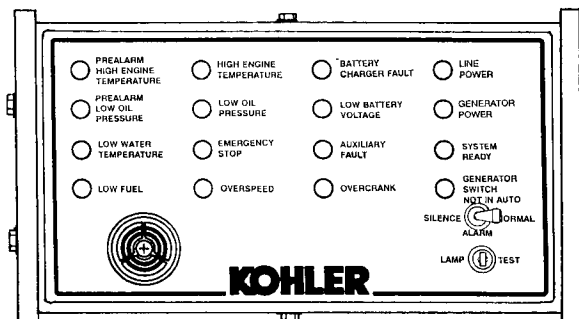

- **OVERSPEED. (39)**  
Lamp lights if generator set shuts down due to an overspeed condition. (above 70 Hz)
- **BATTERY CHARGER FAULT. (61) \***  
Lamp lights if charger has this option and malfunctions.
- **LOW BATTERY VOLTAGE. (62) \***  
Lamp lights if battery or charging voltage drops below a preset level (on charger). Lamp will also light if undervoltage condition occurs due to battery or charger malfunction when the generator is running.
- **AUXILIARY FAULT. (26)**
  - Lamp lights 5 seconds after a high oil temperature or low coolant level fault.
  - Lamp lights if optional overvoltage condition arises.
  - Lamp lights if optional emergency stop switch is reset with generator master switch in the AUTO or RUN position.
  - Lamp lights is activated by sensing devices connected to controller auxiliary immediate shutdown ports (P1-17 and P1-18)
  - Lamp flashes if the generator set DC supply is connected with the master switch in the RUN or AUTO position.
  - Lamp flashes due to low voltage or hardware reset of the Microprocessor.
- **OVERCRANK (12)**  
Lamp lights after 15 seconds if starter or engine will not turn (locked rotor). Lamp will also light if generator does not start after 45 seconds of continuous cranking or 75 seconds of cyclic cranking.

## ACCESSORIES

### REMOTE ANNUNCIATOR PANEL (optional) 16 LIGHT

#### - LINE POWER (58) \*

Lamp lights when power is being supplied by a source other than the generator set. When the lamp is on the SYSTEM READY lamp should also be lit.

#### - GENERATOR POWER (59) \*

Lamp lights when power is being supplied by the generator set.

#### - SYSTEM READY (60) \*

Lamp lights to indicate the generator is ready for start-up if electrical load is transferred to the set. The SYSTEM READY lamp will light only when the generator master switch is in the AUTO position.

#### - GENERATOR SWITCH NOT IN AUTO (80)

Lamp lights when the generator set master switch is not in the AUTO position.

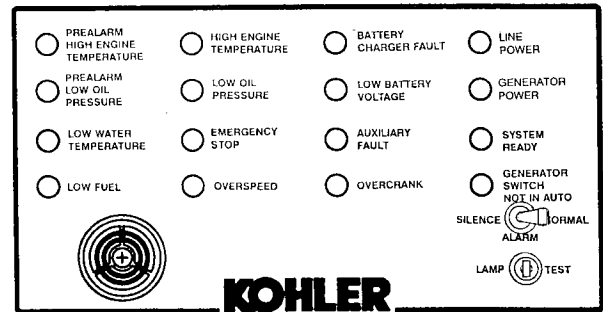



# ACCESSORIES

## REMOTE ANNUNCIATOR PANEL (optional) 16 LIGHT (cont'd)

The Monitor can be either flush or surface mounted at a distance up to 1000 ft. from the generator controls and is powered by the set battery (12 or 24vdc).

A fused dry contact relay assembly is included in the kit and should be installed at the generator set. It provides an isolated interconnection to prevent any stray signals possibly radiated in the remote cable run from being induced into the circuit. It is also recommended that the customer connection kit terminal strip be used when installing this option.

The appropriate relay coil will be energized when a ground signal is received from the Micro-computer board (TB1).

The normally open (NO) contacts from the TB2A terminal strip will supply the battery ground input signal to the Monitor alarm and corresponding indicator lamp.

The input harness is connected to provide monitoring of the following conditions via the assigned K relays.

- 63 LOW FUEL (K12)
- 35 LOW WATER TEMP (K13)
- 41 PRE-LOW OIL PRESS.(K8)
- 40 PRE-HIGH ENG.TEMP.(K14)
- 39 OVERSPEED (K1)
- 48 EMERGENCY STOP (K9)
- 38 LOW OIL PRESS. (K4)
- 36 HIGH ENG. TEMP. (K3)
- 12 OVERCRANK (K2)
- 26 AUXILIARY FAULT (K5)
- 62 LOW BATT. VOLTS (K11)
- 61 BATT. CHARGER FAULT (K10)
- 58 LINE POWER (T/S 13)
- 59 GENERATOR POWER (T/S 10)
- 60 SYSTEM READY (K6)
- 80 NOT IN AUTO (K7)

Input voltage supply is provided to terminals 42B (+) and N (-) from the generator set battery. The circuit is protected by a 10 amp fuse located in the Dry contact kit box. Normal current draw (System Ready indicator) is 20ma on 24v battery systems.

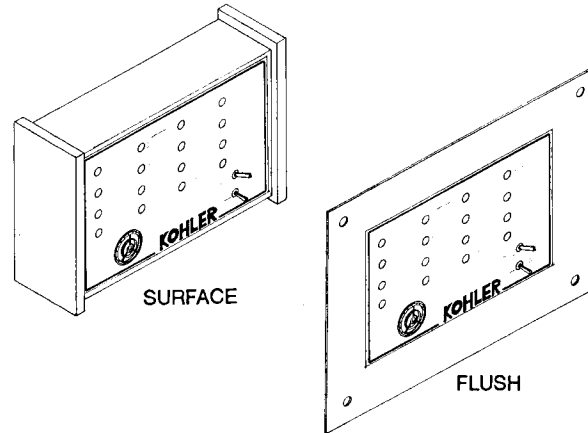

DECISION MAKER  
CIRCUIT BOARD

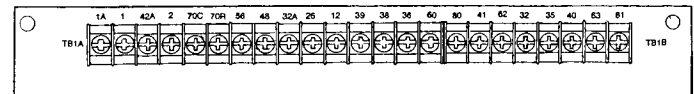

CONNECTION KIT  
TERMINAL STRIP

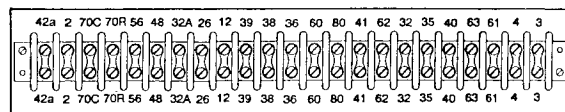

DRY RELAY  
CONTACT KIT

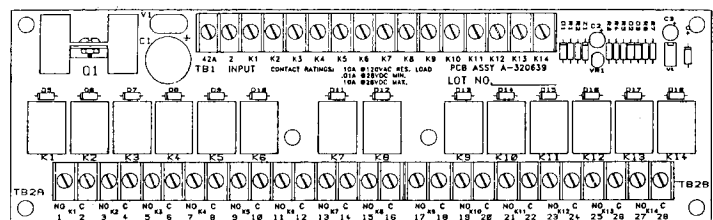

N.O. (K) contacts

ANNUNCIATOR PANEL

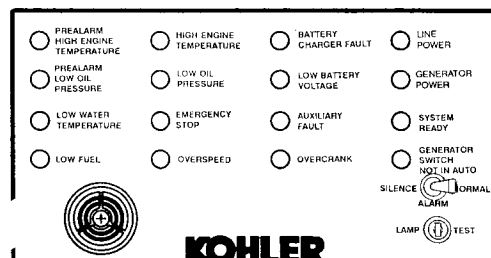
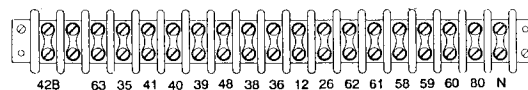

INPUTS FROM DECISION MAKER CIRCUIT BOARD

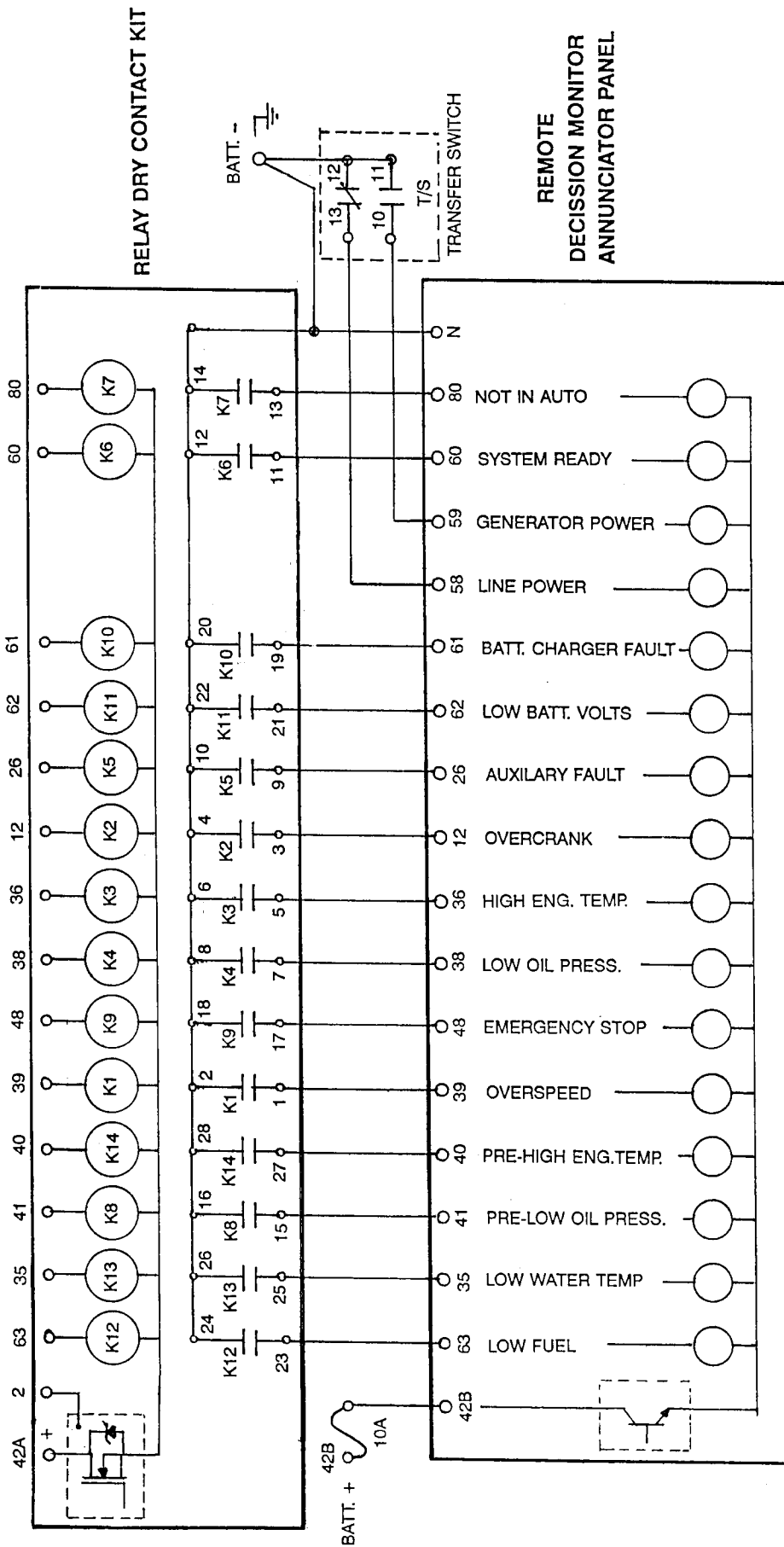

**NOTE:** All wiring between the Relay contact kit, transfer switch etc. and the Remote annunciator is customer supplied.

# Dec 3+ Controller Accessory Connections

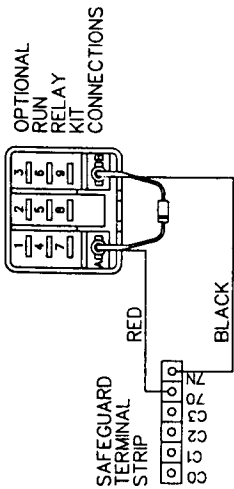
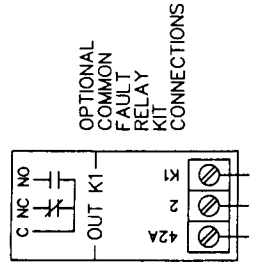
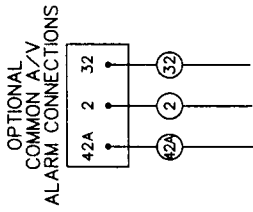
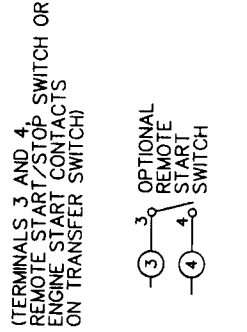
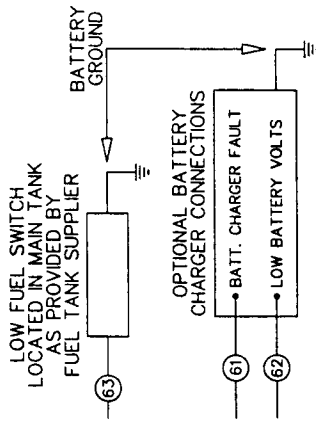

(70) BATTERY VOLTAGE PRESENT ONLY WHEN GENERATOR IS OPERATING.

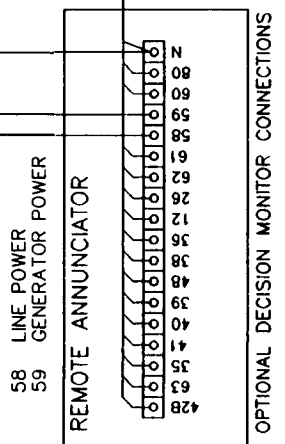
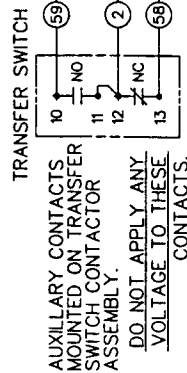
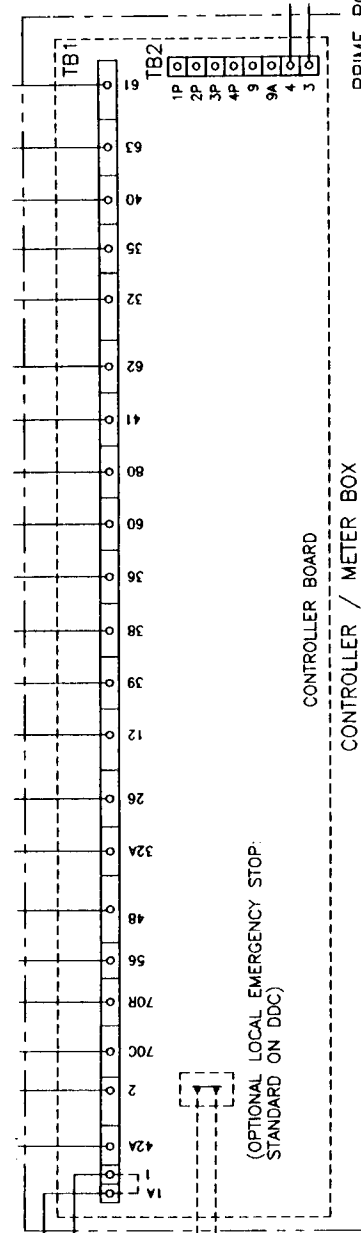
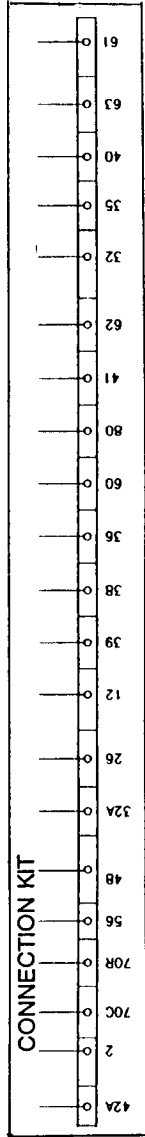
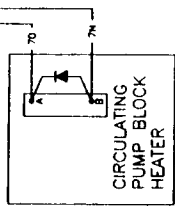

PLACE JUMPERS ACROSS TB2-1P TO TB2-2P, TB2-3P TO TB2-4P & TB2-4 TO TB2-3. TO POWER-DOWN CONTROLLER PLACE GENERATOR MASTER SWITCH IN "OFF/RESET" TO START GENERATOR. MOVE MASTER SWITCH TO "AUTO" POSITION.

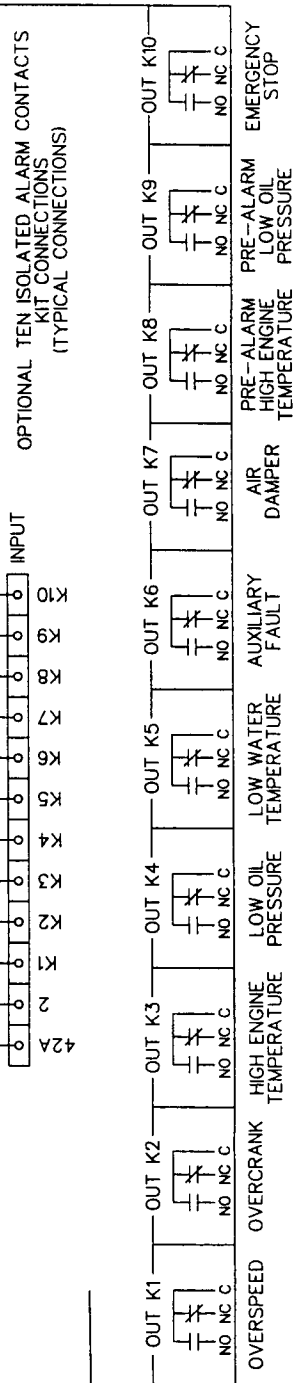

# Dec-3 Controller Accessory Connections

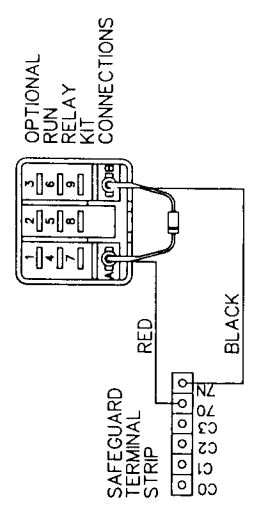
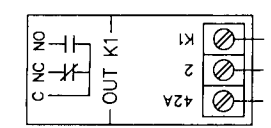
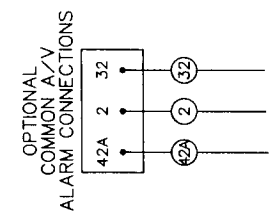
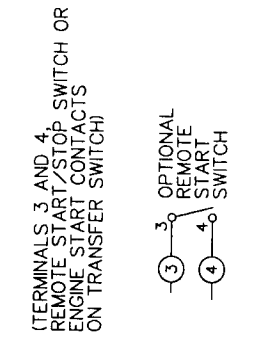
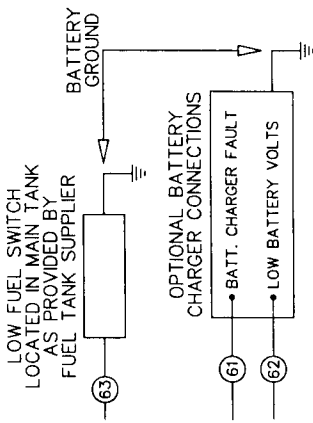

(70) BATTERY VOLTAGE PRESENT  
ONLY WHEN GENERATOR IS OPERATING.

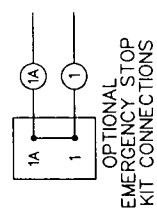
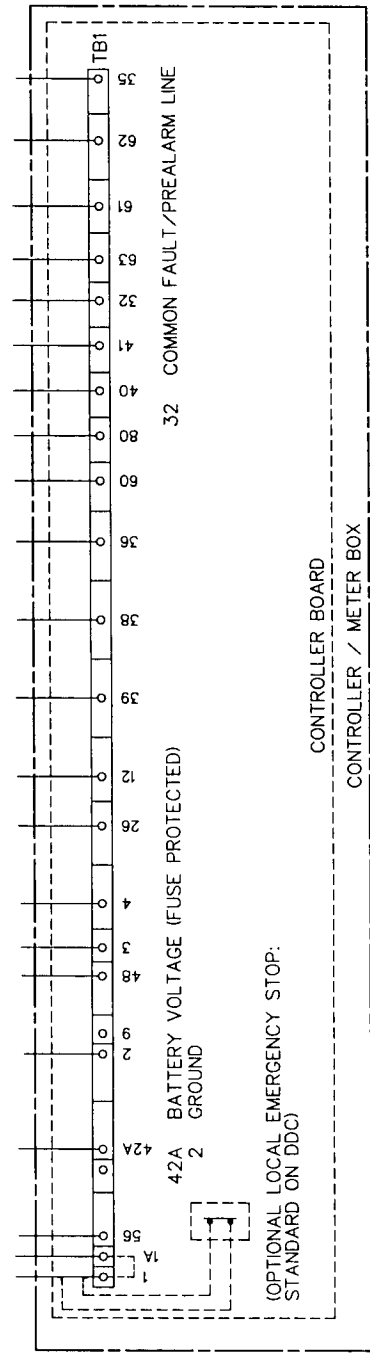
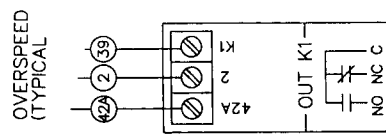
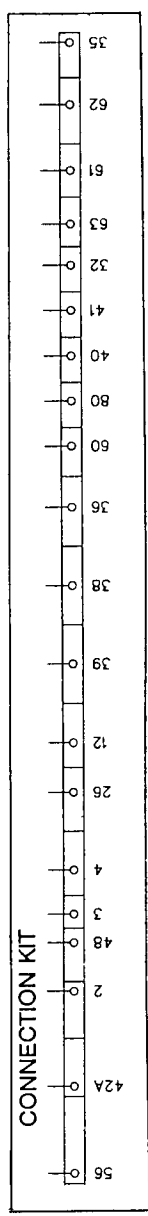

OPTIONAL  
ONE ISOLATED ALARM  
CONTACT  
KIT CONNECTIONS

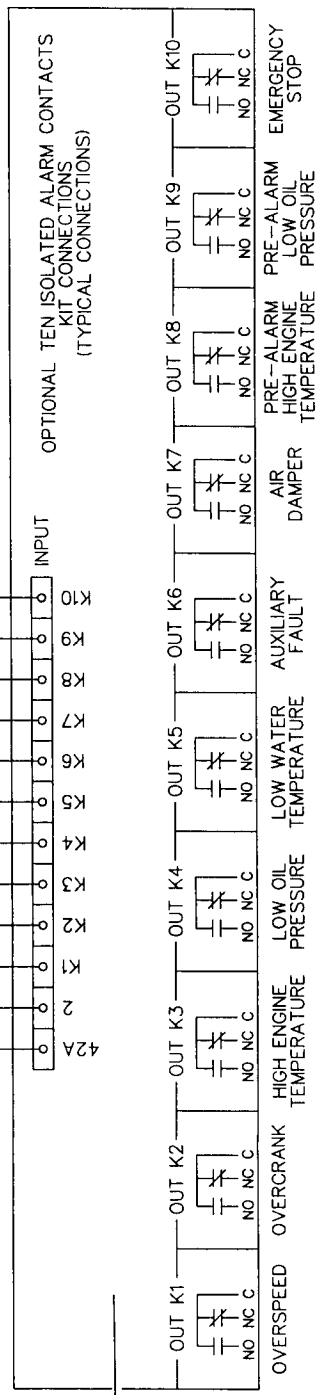
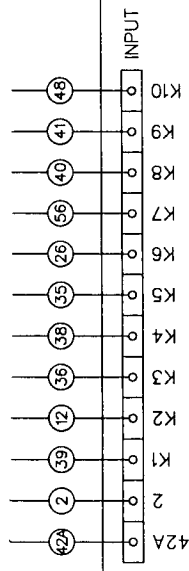
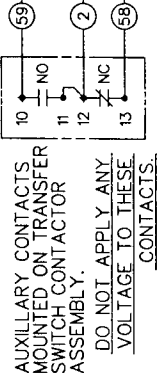

# SYSTEM CONFIGURATION FOR ACCESSORY CONNECTIONS

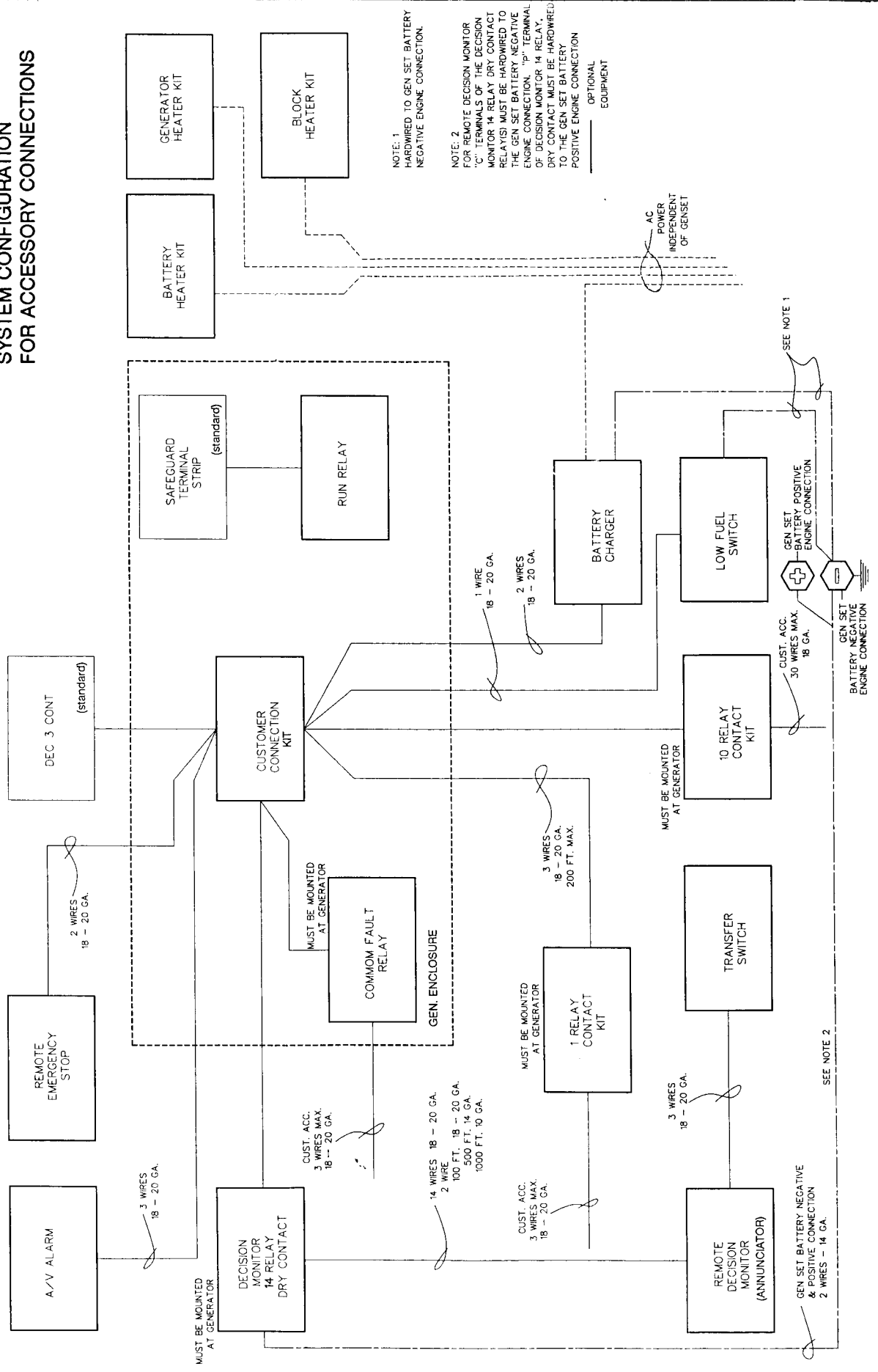

NOTE: 1  
HARDWIRED TO GEN SET BATTERY  
NEGATIVE ENGINE CONNECTION.

NOTE: 2  
FOR REMOTE DECISION MONITOR  
"C" TERMINALS OF THE DECISION  
MONITOR 14 RELAY DRY CONTACT  
RELAY(S) MUST BE HARDWIRED TO  
THE GEN SET BATTERY NEGATIVE  
ENGINE CONNECTION. "B" TERMINAL  
OF DECISION MONITOR 14 RELAY;  
DRY CONTACT MUST BE HARDWIRED  
TO THE GEN SET BATTERY  
POSITIVE ENGINE CONNECTION  
OPTIONAL  
EQUIPMENT

SEE NOTE 1

SEE NOTE 2



## GLOSSARY

**Alternating Current — (Symbol AC):** A current which periodically reverses in direction and changes its magnitude as it flows through a conductor or electrical circuit.

The magnitude of an alternating current rises from zero to maximum value in one direction, returns to zero, and then follows the same variation in the opposite direction. One complete alternation is one cycle or 360 electrical degrees. In the case of 60-cycle alternating current the cycle is completed 60 times per second.

Alternating current is far more widely used than direct current because it can be easily transformed from one voltage to another for transmission and use, and electricity is always generated in machines as alternating current. A DC generator is basically an AC generator with the addition of a device called a commutator which changes AC to DC.

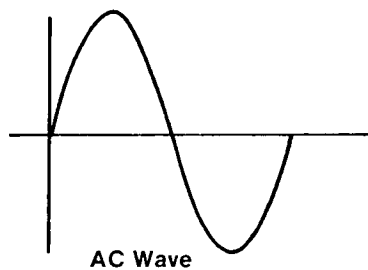

**Alternator:** A term frequently used for AC generator. "AC generator" is preferred.

**Ambient Temperature:** The temperature of the surrounding air in which the equipment operates. This may be expressed in degrees Celsius or Fahrenheit. Normally, ambient temperature is expressed in degrees Celsius when referring to electrical equipment. Degrees Fahrenheit is more frequently used for engines and mechanical equipment.

**Ammeter:** This device measures current. Current measuring instruments must be connected in series with a circuit and never in parallel with it. AC ammeters are often used with current transformers to reduce meter current. Typical transformer ratios are 100:5 and 500:5.

**Amortisseur Winding:** The revolving field structures of synchronous machines are provided with poles with faces slotted parallel to the shaft. Conducting bars are built into these slots, and the ends of the bars are short circuited to form a structure similar to the squirrel-cage winding of an induction motor. These windings dampen out the tendency of the generator to "hunt" with load changes. They are required for all revolving field generators which are driven by internal combustion engines and which may be required to operate in parallel and/or single-phase.

**Ampere — (Symbol I, A, i, a):** A unit of measurement of the rate of flow of electricity. One ampere of current flows when a pressure of one volt is applied across an impedance of one ohm.

**Apparent Power — (Symbol kVA, VA):** When the current and voltage are not in phase, i.e., voltage and current do not reach corresponding values at the same instant, the resultant product of voltage and current is apparent power instead of actual power. Apparent power is measured in volt-amperes or kilo-volt-amperes. Actual power (kW) is the product of kVA and the power factor.

**Armature Reaction:** We know that if current flows through a coil surrounding an iron core, a magnet is formed. This is true of the stator as well as of the rotor. Current flowing through the stator coils will result in magnetic poles, in general, opposite in position and direction to the poles of the rotor. This characteristic of the stator, tending to oppose and to force down flux developed by the rotor, is known as armature reaction.

**Automatic Synchronizer:** This device, in its simplest form, is a magnetic-type control relay which will automatically close the generator switch when the conditions for paralleling are satisfied.

**Automatic Transfer Switch:** This switch is a double-throw, electrically operated switch which will, on a given signal, open one set of contacts and throw over to the second set of contacts. As normally used in hospitals, television and radio stations and other applications where automatic emergency power is used, the switch automatically transfers a load from a normal source of electrical power to an emergency source on failure of the normal. The load is automatically returned to the normal source when that source is restored to proper operating condition. Relays for delayed operation, engine starting, manual reset and similar features are available. As normally used the switch is electrically operated, mechanically held and has a positive interlock to prevent the two sets of contacts being engaged at the same time.

**American Wire Gauge — (Symbol Awg):** Wires are manufactured in sizes numbered according to a table, known as the American Wire Gauge. (This gauge was formerly known as Brown & Sharp, abbreviated B&S). As the wire diameters become smaller, the gauge numbers become larger. The ratio of the diameter corresponding to a given gauge number to the diameter corresponding to the next higher gauge number is a constant 1.123. The cross sectional area varies as the square of the diameter. The cross sectional area is approximately halved or doubled every three gauge numbers. The cross sectional area is increased or decreased 10 times for every 10 gauge numbers. Using No. 10 wire as a base (approximate diameter 100 mils, approximate cross sectional area 10,400 circular mils and 1 ohm per 1000 feet) it is possible to quickly estimate cross sectional area and wire size without referring directly to a wire table.

**Broad Range:** Generators having a range within which the output voltage can be adjusted are said to be "broad range" machines. For example a generator rated 416-480-Volt can be adjusted to put out anywhere between 416-Volts and 480-Volts.

**Capacitance (Symbol C):** If voltage is applied to two conductors separated by an insulator, the insulator will take an electrical charge. If an alternating voltage is applied, an alternating current will flow into and out of the insulator (in this case called a dielectric) as it charges and discharges with reversal of applied voltage. On alternating current circuits the charge is a maximum, but the current becomes zero, as the voltage reaches a maximum. The current change thus precedes the voltage change, or the current leads the voltage; this being opposite to inductance. The characteristics of being able to take an electrical charge is known as capacity (C) and is measured in Farads.

**Capacitive Reactance — (Symbol Xc):** When considered in an AC circuit with a definite frequency, capacitance results in a capacitive reactance which is measured in ohms. Capacitive reactance causes the current to lead the voltage by 90 electrical degrees. The value in ohms is determined by the formula:

$$X_c = 1/2 \pi f c$$

**f = frequency (Hz)**  
**c = capacitance (Farads)**  
 **$\pi = 3.1416$**



**Charge:** There are two types of charge, positive (+, proton) and negative (-, electron). An atom with electrons missing is unbalanced — it has more protons than electrons and is therefore positively charged. The same analysis applies to an atom having more electrons than it should — it is negatively charged. Like charges repel each other. Unlike charges attract each other.

**Circuit Breaker:** A special switch used to protect electrical circuits is called a circuit breaker. It is generally designed to open or break the circuit when some abnormal condition, such as an overload occurs. The circuit breaker usually has a higher initial cost than a fused knife switch, but has the advantages of opening the circuit faster and can be reset easier after the cause of the overload has been removed. Circuit breakers are difficult to size as necessary to protect an engine-driven generator. A circuit breaker rating of 125% generator rating is usually used, however, engine power usually limits generator load to less than 125%.

**Compound:** A *chemical* combination of elements that cannot be separated by simple physical means such as by dissolving one out and leaving the others or by filtering or distillation, etc. There must be a chemical reaction to separate a compound.

**Continuous Standby:** The rating at which a generator set may be operated for the duration of a power outage. No overload capacity is guaranteed.

**Cross Current Compensation:** Cross current compensation is used to divide reactive kVA equally between generators operating in parallel, and is accomplished by a current transformer. Division of reactive kVA between AC generators operating in parallel is a function of generator excitation. When operating AC generators in parallel it is necessary that the reactive kVA outputs of the individual generators be equalized. This is to prevent one generator from being overloaded by carrying all of the reactive kVA because its individual excitation is higher than that of the other machines. It is accomplished by the current transformer limiting or controlling the voltage sensitive element of each voltage regulator with reactive current. This reactive current divides the kVAR among the generators according to their rating and enables the generators to all operate at the same power factor. Frequently, reactive droop compensation is used without the cross-current connection.

**Current:** Current is a flow of electricity. DC flows from negative to positive. AC alternates in direction.

The standard symbol for current is "I" and it is measured in Amperes (Amps).

The current flow theory is used conventionally in power and the current direction is positive to negative — opposite the flow of electrons.

**Cyclic Irregularity:** Cyclic irregularity is the ratio of magnitude of fluctuation of speed over the average speed. This is a calculated value based upon firing diagrams and the mass of the system. Torsional characteristics are not involved and the system is assumed rigid.

$$\text{Cyclic Irregularity Ratio} = \frac{\text{Max. Instantaneous Speed} - \text{Min. Instantaneous Speed}}{\text{Average Speed}}$$

Its application to specific problems is critical in very large, slow speed engines driving generators having many poles (18 or 36), or small 4 or 6 pole sets having less than one firing stroke per 2 cycles, where the instantaneous speed of the flywheel may drop considerably between firing impulses.

**Delta Connection:** The delta connection is so named because it resembles the Greek letter. To make a delta connection, the finish end of the first winding is connected to the start of the second winding, the finish of the second winding is connected to the start of the third winding and the finish of the third winding is connected to the start of the first winding.

Modern generators are normally connected in a wye or star pattern rather than delta for several reasons. The delta-connected generator has no advantages over the wye-connected machine, and the wye machine has the advantage of being able to bring out the neutral wire. Also, in the delta-connected machine it is difficult to design the generator to keep the circulating currents low in magnitude. Normally the wye-connected machine will give better wave form characteristics than the delta-connected generator. In the wye machine the harmonics tend to cancel each other out when line-to-line voltage is checked between two legs or phases. In the delta-connected machine the line-to-line voltage is across one coil or set of coils and there is no cancellation of harmonic effects, except that the third harmonic and its multiples are shorted out, and do not appear in the output. Delta-connected generators are used to supply 120/240-Volt, three-phase/single-phase, 4-wire systems.

**Dielectric Test:** National Electrical Manufacturers Association (NEMA) standards provide that each generator of 250 watts output or more be given the following high potential factory test to check generator insulation:

Stator Windings — apply two times the normal voltage plus 1000-Volts.

Field Windings — apply ten times the exciter voltage, but in no case less than 1500-Volts.

**Direct Current — (Symbol DC):** A current that flows in one direction only for a given voltage and electrical resistance. A direct current is usually constant in magnitude for a given load. Electricity is generated as alternating current in revolving machines. In DC generators the AC current is changed to direct current by commutation. While DC voltage is substantially constant in a DC generator, a slight ripple is due to commutation.

**Distribution Panel:** Multicircuit switchgear panel used to feed power to individual loads.

**Drip-Proof:** Per NEMA MG1-1.20 a drip-proof generator is an open machine in which the ventilating openings are so constructed that drops of liquid or solid particles falling on the machine at any angle not greater than 15° from the vertical cannot enter the machine either directly or by striking and running along a horizontal or inwardly inclined surface.

**Dual Range Generator:** Any 10-wire or twelve-wire generator can be connected such that the stator windings in each phase are in series or parallel. When in series the output voltage will be high. When in parallel the output voltage will be one half of the high voltage, but the current capacity will be doubled. A typical rating would be 240/480-Volt. If the machine is also broad range, a typical rating would be 208-240/416-480-Volt.

**Efficiency:** Input times efficiency equals output, or efficiency equals output divided by the output plus losses. Efficiencies of generators are commonly given at 4/4, 3/4, and 1/2 load. Unless otherwise stated, the efficiency of the generator is always based on the kVA and power factor at which it is rated.

**Element:** A substance which cannot be broken down into a simpler substance which will retain the original characteristics. For example, copper, hydrogen and oxygen are all elements; they cannot be reduced to anything simpler without destroying their properties.

**EMF:** Electromotive Force. See Volt.

**Exciter:** Synchronous AC generators require DC field excitation current. Most such generators today are furnished with exciters which are AC generators having rectified output.

**Flywheel Effect:** Internal combustion engine-driven generator sets must be provided with flywheel effect to meet the following conditions:

1. Harmful torsional vibrations must be avoided;
2. Speed variation, when operating alone, must be reduced to a point where objectionable variations in voltage or frequency are avoided;
3. Operation in parallel with a large system must be possible.
4. The natural frequency must differ from forcing frequencies, of generator sets with which it is operating in parallel, by at least 20%.

In accordance with present practice it is the responsibility of the engine manufacturer or set assembler to determine that the proper flywheel effect is provided to meet the conditions outlined above. The generator manufacturer will provide information on shaft stiffness and other details which are required in these calculations.

**Frequency — (Symbol Hz):** The number of cycles per second the current alternates is called the frequency. Most common frequency in the United States is 60 Hz. 50 Hz current is used in most countries. Generators are also made in special high frequencies for certain applications. The unit for measurement of frequency is the Hertz equivalent to one cycle per second.

**Harmonics:** Any irregularity in a wave form can be resolved into a fundamental sine wave of the system frequency and one or more sine waves of higher frequencies which modify the fundamental. In AC circuits only odd harmonics occur. The possible harmonics for various stator connections follow:

Connection	Grounded	Possible Harmonics
Wye	Yes	1, 3, 5, 7, 9, 11, etc.
Wye	No	1, 5, 7, 11, etc.
Delta		3, 9, 15, 21, etc. (circulating) and 1, 5, 7, 11, etc. (line)

**Impedance — (Symbol Z):** The total opposition to the flow of alternating current in a circuit that contains resistance and reactance is called impedance. Strictly speaking the reactance component takes into account both the capacitive and inductive components, but for all practical purposes in power circuits we can neglect the capacitive reactance ( $X_C$ ).

$$\text{Total Impedance} = Z = \sqrt{R^2 + (X_L - X_C)^2}$$

**R** = pure resistance

**X<sub>L</sub>** = inductive reactance

**X<sub>C</sub>** = capacitive reactance

If we neglect  $X_C$  the formula reduces to:

$$Z = \sqrt{R^2 + X_L^2}$$

**Inductance (L):** Any device with iron in the magnetic structure has what amounts to magnetic inertia. This inertia opposes any change in current. It is quite apparent on alternating current since the voltage is continually changing in instantaneous value and this inertia has the effect of continually causing change in current to a lag behind changes in voltage. The characteristic of a circuit which causes this magnetic inertia is known as self inductance; it is measured in henries and the symbol is "L".

**Inductive Reactance (X<sub>L</sub>):** When considered in an AC circuit with a definite frequency inductance results in an inductive reactance ( $X_L$ ), which is measured in ohms and is determined as follows:

$$X_L \text{ (ohms)} = 2 \pi f L$$

**Inertia:** Inertia means the resistance of a mass to a change in velocity. A mass in motion will tend to travel in a straight line and at the same speed unless acted upon by an external force. Inertia is the force that pushes you forward when an automobile is decelerating or comes to a sudden stop.

**Interruptible Service:** A plan whereby an electric utility, elects to interrupt service to a specific customer at any time. Special rates are often available to customers under such agreements.

**Insulation:** Insulating materials are used in all electrical machinery to isolate and maintain the flow of current through the conductors. Temperature influences the life of insulation. The failure of insulating materials is generally mechanical, resulting from reduced strength caused by extended exposure to moisture, foreign materials and resulting higher temperatures than the limiting temperature of the materials used. Most insulation used in today's generators is Class F, with a permissible temperature rise of 221° F (105° C) continuous, and 266° F (130° C) standby.

**Isochronous Governor:** A governor that maintains constant engine speed from no-load to full-load. It is a zero-droop governor. Typical accuracy is  $\pm 0.25\%$  of rated speed.

**Kilowatt — (Symbol kW):** Power is the rate of doing work. Electric power is expressed in Watts or kiloWatts (1000 Watts). One horsepower equals 0.746 kW or approximately 3/4 kW. Inversely one kW equals 1.34 horsepower. Actual power (kW) equals apparent power (kVA) times power factor (expressed as a decimal).

$$\text{Horsepower} = \frac{\text{kW}}{.746 \times \text{Generator Efficiency}}$$

To calculate the kW input of an electric motor —

$$\text{Kilowatts} = \frac{\text{Motor Horsepower} \times .746}{\text{Motor Efficiency}}$$

A rule of thumb based on 90% generator efficiency —

$$\text{Engine hp} = \text{Generator kW} \times 1\text{-}1/2$$

For single-phase generator —

$$\text{kW} = \frac{\text{Volts} \times \text{Amperes} \times \text{Power Factor}}{1000}$$

For three-phase generator —

$$\text{kW} = \frac{\text{Volts} \times \text{Amperes} \times \text{Power Factor} \times \sqrt{3}}{1000}$$

**Kilowatt Hour — (Symbol kWh):** The measure of electrical energy is the kilowatt hour. One kilowatt of electrical power consumed for one hour equals one kilowatt-hour (kWh) of electric energy. This energy can be measured by a kilowatt-hour meter which is a small, sensitive electric motor, the rotor speed of which is proportional to the kilowatts flowing in the circuit to which the meter is connected. Revolutions of the motor are transmitted through a gear train to pointers on a register dial calibrated in kWh. Kilowatt hour meters can be used to give approximate instantaneous kW load readings by measuring the rate of disc rotation.

**Kilovolt-Ampere — (Symbol kVA):** In AC circuits, kVA is the measure of the apparent power flowing in the circuit. To find the true or actual power (kW), the kVA must be multiplied by the power factor (expressed as a decimal).

**Magnetism:** A phenomenon of certain materials (iron, nickel, cobalt), such that, when the atoms are aligned within the materials, a field of force is set up which can effect other magnetic materials that are within that field. One end of a magnet is called the north pole and the other end the south pole.

**Magnetic Field:** The lines of force due to the proper alignment of the atoms are called magnetic flux lines and make up the magnetic field. By convention, the lines begin at the north pole and end at the south pole.

**Magnetizing Current:** Transformers, motors and other electro-magnetic devices containing iron in the magnetic circuit must be magnetized in order to operate. It is customary to speak of the lagging inductive current as a magnetizing current.

**Molecule:** The smallest particle of a **compound** that retains the properties of that compound. A molecule is made up of two or more atoms depending on the compound. One molecule of water (H<sub>2</sub>O) is made up of two hydrogen atoms and one oxygen atom.

**National Electrical Code — (NEC):** The National Electrical Code is a volume of standard electrical rules prepared by the National Fire Protection Association. The code contains basic minimum provisions considered necessary for safety. These minimum rules are modified, expanded and interpreted by local electrical safety governing bodies. Local electrical and building inspectors in a particular community should be consulted for answers to specific questions and interpretation of the local codes covering a particular installation.

**National Electrical Manufacturers Association — (NEMA):** This is an organization of electrical manufacturers set up to provide limited information pertaining to certain types of electrical equipment. A main function of the organization is to establish uniform nomenclature throughout the industry and to promote manufacturing economics. NEMA Standards do not cover traction generators, arc welding generators or the self-regulated type generator because these are specialized types of equipment from manufacturers setting acceptable standards.

**NEMA Design B:** Normal-Torque, general purpose induction motors. These motors comprise about 90% of all induction motors.

**NEMA Design C:** High-Starting-Torque, low-starting-current motors — often used for starting and running loaded compressors, pumps, etc., where a high starting torque is required.

**NEMA Design D:** High-Starting-Torque, High-slip motors — are usually found in loads having a flywheel effect, such as elevators, hoists, punch presses, etc.

**Ohm:** The unit which represents the amount of electrical resistance or impedance to the flow of electric current.

**OHM's Law:** This is the fundamental law of electricity. The intensity of the current in any electrical circuit is equal to the difference in potential in volts across the circuit divided by the resistance in ohms, of the circuit. This law may be expressed in three ways:

For DC —

$$I = \frac{E}{R}$$

$$R = \frac{E}{I}$$

$$E = IR$$

where: I = current in amperes  
E = potential difference in volts  
R = resistance in ohms

For AC —

$$I = \frac{E}{Z}$$

$$Z = \frac{E}{I}$$

$$E = IZ$$

where:  $I$  = current in amperes

$E$  = potential difference in volts

$Z$  = electrical impedance in ohms. For direct current  $Z$  is numerically equal to the resistance  $R$ . In AC circuits  $Z$  is made up of resistance  $R$  and reactance  $X$ . (See impedance)

One volt is required to cause one ampere of electric current to flow through an impedance of one ohm.

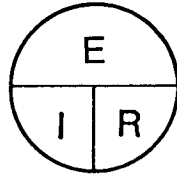

With this diagram you cover the value desired with your finger and the proper mathematical relationship remains showing. For example, if you want to determine the resistance ( $R$ ), you find  $\frac{E}{I}$ . Therefore,  $R = \frac{E}{I}$ .

**Open Circuit Excitation:** With the rotor excited and turning over at full speed, an alternating voltage will be generated. If the generator terminals are left open circuited and we supply proper values of excitation we obtain the open circuit saturation curve.

Above about 75% normal operating voltage a condition known as saturation occurs. The magnetic strength (flux) then does not increase proportionately with increase in excitation, but increases somewhat less rapidly. The ratio of excitation increase to voltage increase at the intersection of the open-circuit saturation curve and the normal voltage line is known as the saturation constant.

**Overload:** NEMA Standard MG1-16.41 — Overload capability states: general purpose, prime power synchronous generators shall be capable of carrying 10% over-load for two hours out of any 24. It is recognized that the voltage, power factor and temperature rise will differ from rated values when generators are subjected to overload condition.

**Overspeed:** NEMA Standards for synchronous generators MG1-16.46 — Overspeeds states: Salient pole synchronous generators shall be so constructed that, in an emergency, they will withstand an overspeed of 25% without mechanical injury.

**Parallel Operation:** Units to be paralleled must have the same frequency, the same number of phases, the same voltage, the same phase rotation. The latter merely means that the voltages across the terminals must reach their maximum and minimum values in the same order. Otherwise, the magnetic forces would try to turn the rotors in opposite directions.

**Power:** DC power is always the product of Volts times Amps and is expressed in Watts.

$$\text{Watts} = \text{Volts} \times \text{Amps} \quad (P = E \times I)$$

AC output of a generator is the apparent power and is equal to the Volts times Amps, as measured at the generator.

$$\text{Apparent Power (kVA)} = \frac{EI}{1000}$$

The apparent power (kVA) developed by the generator is used in two places:

1. Useable power for the load (kW)
2. Lost power due to reactance (kVAR) of the load

The power used in the load is called the useable or real power and is expressed in Watts or kiloWatts (kW). Whenever the words Watts or kW is used, it means useable power.

The power lost because of the reactance is called reactive power or kilo Volt-Amps-reactive (kVAR). This lost power does no work.

The following triangle is a graphic representation of the relationships between apparent, real and reactive power.

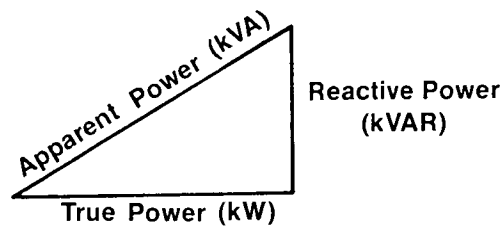

**Power Conditioner:** A device which removes undesirable transients and distortion from a power source.

**Power Factor — (Symbol PF):** Power factor is the ratio for expressing what part of the apparent power (kVA) flowing in an AC circuit is true power (kW).



$$\text{Power Factor} = \frac{\text{kW}}{\text{kVA}}$$

At unity power factor the kW and kVA are equal. At any power other than unity (leading or lagging power factor), the kVA are greater than the kW. When this is true there is a reactive component of the total kVA flowing in the circuit.

Mathematically, power factor is equal to the cosine of the angle by which the current leads or lags the voltage.

With a low power factor load, the reactive component is larger and thus more kVA capacity is required of the generator supplying the power. For a given kW load the increase in kVA caused by a low power factor means increased Amperes through the coils. The capacity (kVA) of generators, transformers, etc., is normally limited by the current capacity and heating limits of the coils.

**Prime Power:** The rating at which a generator may be operated continuously as a sole source of power, with intermittent overloads up to the standby rating.

**Reactive Droop Compensation:** A system similar to cross current compensation (see definition) in which an artificial voltage droop is introduced on reactive power, only as necessary to force generators to divide reactive load when operating in parallel. No cross-current connection between generators is required. This system is usually preferred to cross-current compensation.

**Reactive Kilovolt-Amperes — (Symbol RkVA or kVAR):** Reactive kVA is the measure of the reactive or magnetizing component of the total kVA flowing in a circuit. The out-of-phase or reactive component serves the important function of magnetizing the magnetic equipment, i.e., induction motors, transformers, etc., during a portion of each cycle. The magnitude of this component is determined by the proportion of magnetic equipments to the pure resistance loads which determines the amount that current lags the voltage. Mathematically the tangent of the angle of lag is equal to the reactive kVA divided by the kW. In a three-phase circuit:

$$\text{kVAR} = \frac{\sqrt{3} \times \text{volts} \times \text{reactive amperes}}{1000}$$

**Rectifier:** If only alternating current is available, it may be converted into direct current by using devices which offer a high resistance to the flow of current in one direction and a low resistance to the flow in the opposite direction. These devices are called rectifiers. A common rectifier is the diode.

**Regulation:** Voltage regulation is defined as the rise in voltage, (field current and speed remaining constant), when full load is thrown off the generator.

$$\% \text{ Voltage Regulation} = \frac{(\text{voltage at no load} - \text{voltage at full load}) \times 100}{\text{voltage at full load}}$$

Speed regulation is similar.

$$\% \text{ speed regulation} = \frac{(\text{no load rpm} - \text{full load rpm}) \times 100}{\text{full load rpm}}$$

**Resistance:** Electrical resistance is that quality of an electric circuit that opposes the flow of current through it. In the electric circuit, the larger the diameter of the wires the lower will be their electrical resistance to the flow of current through them. Temperature also affects the resistance of electrical conductors to some extent. In most conductors (copper, aluminum, etc.) the resistance increases with temperature.

**Resistor:** A device used to limit current flow.

**Rheostat:** An adjustable resistance used for the purpose of controlling, limiting or adjusting the amount of current flow in a circuit is called a rheostat or potentiometer. Rheostats are often so constructed that the resistance in the circuit may be varied by turning a knob or lever.

**Right-Hand Rule:** When using the "current flow theory" the current flows from positive to negative. If the thumb of the right hand is pointed along the conductor in the direction of current flow then the fingers, when wrapped around the conductor, will indicate the direction of the magnetic lines of force.

**Short-Circuit Ratio:** The ratio of the exciter field current for rated open circuit armature voltage at rated frequency to the field current for rated armature current on sustained symmetrical short circuit at rated frequency is called the short-circuit ratio of the generator.

**Single-Phase:** A single-phase AC circuit is generally served by 2 or 3 wires. Single-phase is most commonly used for lighting and fractional-horsepower loads. Single-phase may be obtained from a single-phase generator, from a three-phase ten or twelve lead generator properly connected, or from the individual phases of a three-phase generator.

**Star Connection:** See Wye Connection.

**Starting kVA:** Induction motors demand more kVA to start than is required for steady state operation. "Starting kVA" is used to define the condition of this extra demand, which normally lasts for a brief period of seconds or less. It is a transient effect, but of great importance. Standard motors have a code letter indicating starting kVA per hp.

**Synchronous Speed:** The number of poles in an AC generator is directly related to the synchronous or operating speed. Any speed can be obtained that corresponds to any even number or pair of poles and the desired frequency.

$$N = \frac{120f}{P}$$

**f** = frequency in cycles per second

**N** = synchronous speed in RPM

**P** = Number of poles

60 Hz		50 Hz	
rpm	Number of Poles	rpm	Number of Poles
1800	4	1500	4
1200	6	1000	6
900	8		

To maintain rated frequency, the speed of the generator must be maintained as shown above.

**Synchroscope:** A synchroscope is an instrument for indicating when generators are in proper phase relation for connecting in parallel and at the same time showing whether the incoming generator is running fast or slow. The instrument has two independent circuits, one being connected to the incoming generator and the other to the bus. The magnetic fields set up by these two circuits cause the hand to rotate. When the hand comes to a standstill at the mark on the dial indicating synchronism, the switch connecting the generator to the bus line may be closed.

**Telephone Influence Factor — (Symbol TIF):** This is the measure of the inductive effect of a power system on nearby telephone circuits as represented by the noise level in the telephone receiver. Technically, the TIF of a three-phase synchronous machine is the ratio of the square root of the sum of the squares of the weighted RMS values of the fundamental and non-triple series harmonics to the TMS value of the normal no-load voltage wave. Telephone receivers are normally designed at a resonant frequency of approximately 1100 Hz. The human ear is very sensitive to the frequency of 1100 Hz. A high TIF indicates presence of harmonics which show as a high pitched hum in a nearby telephone circuit. A 60-cycle pure sine wave has a TIF of unity. A commercially acceptable normal balanced TIF for generators with kVA ratings from 6.25 to 62.5 is 250. From 62.5 to 500 kVA, the normal TIF is 150.

**Temperature Rating:** A generator with a temperature rise rating of 221° F (105° C), is one in which the manufacturer guarantees that the temperature of the generator will not rise more than 122° F (50° C) above an ambient (surrounding air) temperature of 104° F (40° C), when carrying full rated load continuously, at an altitude not exceeding 3300 ft. (1006 m) above sea-level. The term “rated load” implies that the voltage and power factor are as called for by the nameplate of the generator. The same generator is permitted (by NEMA MG1-16.40) to have a 266° F (130° C) temperature rise at a standby rating.

The temperature rise of 221° F (105° C) over ambient temperature given above, is based on measurement of rotor and stator temperature by resistance.

**Three-Phase:** A three-phase AC circuit is a combination of three electrical circuits with a voltage phase difference of 120 electrical degrees (1/3 cycle). A three-phase system may either be 3-wire, or 4-wire (3-wire and a neutral).

**Time Constant:** Any device with iron in the magnetic circuit has what amounts to magnetic inertia. This inertia opposes any change of current even though the voltage is changing. If a generator is short circuited, the time required for the short-circuit current to drop to 36.8% of the original maximum short-circuit current is called the generator time constant. This constant is important in determining the voltage change and voltage recovery of a generator when a sudden load change occurs.

**Torsional Vibration:** Torsional vibrations may be found in the shafting of any rotating machinery in which there is cyclic torque variation. A torsional vibration is a periodic oscillation about a central axis. Should this vibration reach dangerous proportions at a so-called critical speed, serious damage could be inflicted on the associated machinery. The torsional stress of engine generator sets must be calculated and/or tested to assure satisfactory performance.

**Uninterruptible Power Supply (UPS):** A system designed to provide power without delay or transients during any period that the normal power supply is incapable of performing acceptably.

**Volt — (Symbol V or E):** The unit for measuring electric pressure or electromotive force required to force an electric current to flow. Voltage actually shows the difference in electromotive force between two points in a circuit. One volt is required to force one ampere through one ohm of resistance. In an AC circuit having a true sine wave the RMS (root mean square) or effective volts is equal to 0.707 times the maximum volts. The usual AC voltmeter generally measures effective volts, and unless otherwise specified, voltage values are always given as effective volts.

**Voltages — Standard:** The electrical manufacturing industry has standardized to a certain extent on voltages. Standard generator voltages are higher than motor or nominal voltages to allow for some voltage drop in the distribution lines. As a general rule AC electric motors are designed to operate successfully on plus or minus 10% of nameplate or nominal voltage. Most externally regulated generators will operate successfully at plus or minus 10% of nameplate voltage.

#### Alternating Current Standard Voltages

Generator		Motor or Nominal
120	(1)	115
120/240	(2)(3)	115/230
120/208	(2)	200
240	(1)	230
230/400	(2)	380
277/480	(2)	460
400	(1)	380, 400, 440
480	(1)	440
600	(1)	575

(1) 3-phase, 3-wire or single-phase, 2-wire

(2) 3-phase, 4-wire

(3) Single-phase, 3-wire

**Voltage Dip:** "Voltage Dip" is the momentary drop of generator output voltage that occurs whenever a load is added to the system. There is a momentary increase in output voltage whenever a load is removed from the system. This is called "Voltage Rise." "Voltage Rise" is seldom of concern with an adequate voltage regulator.

**Voltmeter:** This instrument when connected across the line will indicate the potential difference in volts. Actually, these instruments usually operate on the same principle as an ammeter except that a high resistance is placed in series with the coil so that the current flow is limited when the meter is connected across the line. The current in the coil is therefore proportional to the line voltage. The scale is not uniformly divided, as on DC voltmeters, for the deflections are very nearly proportional to the square of the voltage. The divisions at the lower part of the scale are crowded so that poor precision is obtained. The divisions at the middle and upper portions of the scale, however, are usually such that they may be read with precision.

**Watt:** See kilowatt

**Wattmeter:** Electric power is measured by means of a wattmeter. Because electric power is a function of current and voltage, a wattmeter must have two elements, one for current and the other for voltage. The power indicated by a wattmeter is a result of the voltage across the load, the current through the load and the power factor on the load. In effect, the wattmeter multiplies the voltage, current and power factor to indicate the true power. When using a wattmeter, take all precautions mentioned for ammeters and voltmeters. In addition, make sure that neither the current nor voltage exceeds the wattmeter capacity. Test the circuit with a voltmeter and ammeter before connecting a wattmeter. The wattmeter scale deflection does not indicate whether the meter is overloaded or not. The voltage may be low and the current high and still indicate a true power within the meter scale limit, but the current element may be overloaded.

**Wave Form:** The shape of the voltage wave which a generator produces is largely under the control of the designer, although most machines are designed to produce waves that closely approximate the true sine wave. Such factors as hysteresis, rotor and stator slotting and armature reactance prevent a perfect sine from being generated.

**Wye Connection:** In a wye or star-connected generator the three start ends of each single-phase winding are connected together to a common neutral point, and the opposite or finish ends are connected to the line terminals. When both low-voltage, single-phase loads and higher-voltage, three-phase loads are encountered, a line to the neutral or common point will serve as a common return circuit for all three phases, i.e., 120/208-Volt, 3-phase, 4-wire machine. In a wye-connected machine the voltage from line to line is equal to the product of 1.73 and the line to neutral voltage. For example, in a 208-Volt machine the line to neutral voltage is  $208 \div \sqrt{3}$ , or 120 volts.

With a 4-wire, 120/208-Volt generator, motors can be operated on the 3-phase, 208-Volt leads, and 120-Volt lighting loads can be connected anywhere in the circuit between the various lines and the neutral. If this is done it is important to balance the 120-Volt, single-phase load as much as possible so that all of the added lighting load is not connected to one single-phase leg or coil.

**Wound-Rotor Motor:** The wound-rotor or slip-ring induction motor is used when it is necessary to vary the rotor resistance in order to limit the starting current or to vary the motor speed. The high resistance is used for starting and cutout when the motor comes up to speed with the resistance cut out. The running characteristics are about the same as a standard squirrel-cage motor. The wound-rotor motor gives high starting torque with comparatively low starting current. On the other hand, its initial and maintenance costs are high and the external resistance is bulky.

Normally a wound-rotor motor will have an instantaneous starting current of 150-160% of rated full-load current and the current during acceleration to approximately 125% of full-load current. With the high resistance in the starting circuit the power factor is high on start, so the usual limiting factor in the selection of a generator set is kW capacity of the engine-generator set.

**Miscellaneous Electrical Formulae:****Power — A.C. Circuits:**

$$\text{Power Factor} = \frac{\text{Watts}}{\text{Volts} \times \text{Amperes}}$$

$$\text{Three-Phase Kilowatts} = \frac{\text{Volts} \times \text{Amperes} \times \text{Power factor} \times \sqrt{3}}{1000}$$

$$\text{Three-Phase Volt Amperes} = \text{Volts} \times \text{Amperes} \times \sqrt{3}$$

$$\text{Three-Phase Amperes} = \frac{746 \times \text{Horsepower}}{\sqrt{3} \times \text{Volts} \times \text{Efficiency} \times \text{Power Factor}}$$

$$\text{Single-Phase Kilowatts} = \frac{\text{Volts} \times \text{Amperes} \times \text{Power Factor}}{1000}$$

$$\text{Single-Phase Amperes} = \frac{746 \times \text{Horsepower}}{\text{Volts} \times \text{Efficiency} \times \text{Power Factor}}$$

**Motor Application Formulae:**

$$\text{Torque (lb.-ft.)} = \frac{\text{Horsepower} \times 5250}{\text{rpm}}$$

For Pumps:

$$\text{Horsepower} = \frac{\text{gpm} \times \text{Head in Feet} \times \text{Specific Gravity}}{3960 \times \text{Efficiency of pump}}$$

For Fans and Blowers:

$$\text{Horsepower} = \frac{\text{cfm} \times \text{Pressure (pounds/sq. ft.)}}{33000 \times \text{Efficiency}}$$

**Speed:**

$$\text{Synchronous rpm} = \frac{\text{Hz} \times 120}{\text{Poles}}$$

$$\text{Percent Slip} = \frac{\text{Synchronous rpm} - \text{Full Load rpm}}{\text{Synchronous rpm}}$$

# Notes

