

# DUAL BEARING ALTERNATORS

MODELS  
GBRF Series  
GBJD Series  
GBIH Series  
GBBT Series  
GBGT Series  
(1250 Thru 6000 WATTS)

**PINCOR**

## owner's guide and PARTS LIST



*Electric Generating Systems Since 1932*

Mfg. by Pioneer Gen-E-Motor Corporation, 5841 West Dickens Avenue  
Chicago, Illinois 60639, phone 312-237-4100 U.S.A.

**PINCOR**  
Products

PART NUMBER 21893-000

REV B

## 240 VOLT RECEPTACLES

3000 thru 4500 watt dual voltage and selector switch models feature as standard a duplex 15-ampere, 240-volt three-prong grounded receptacle (fig. 6).

The 6000 watt model and some special models feature a 20-ampere, 240-volt three-prong grounded twist lock receptacle (fig. 7) in place of the duplex 15-ampere, 240-volt receptacle.

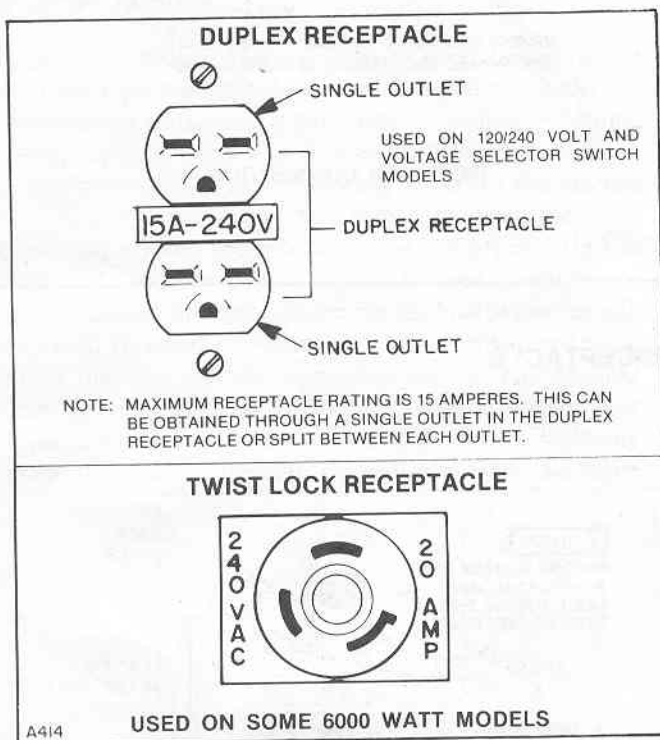

FIGURE 7

## 120 VOLT RECEPTACLES

All models feature either two individual 15 or 20 ampere 120 volt grounded receptacles, a single or dual 15 or 20 ampere 120 volt duplex grounded receptacles, or a single 30 ampere, 120-volt grounded twist lock receptacle. The 6000 watt dual voltage model includes a 20-ampere, 120-volt three-prong grounded twist-lock receptacle. All are covered in the following illustration (fig. 8).

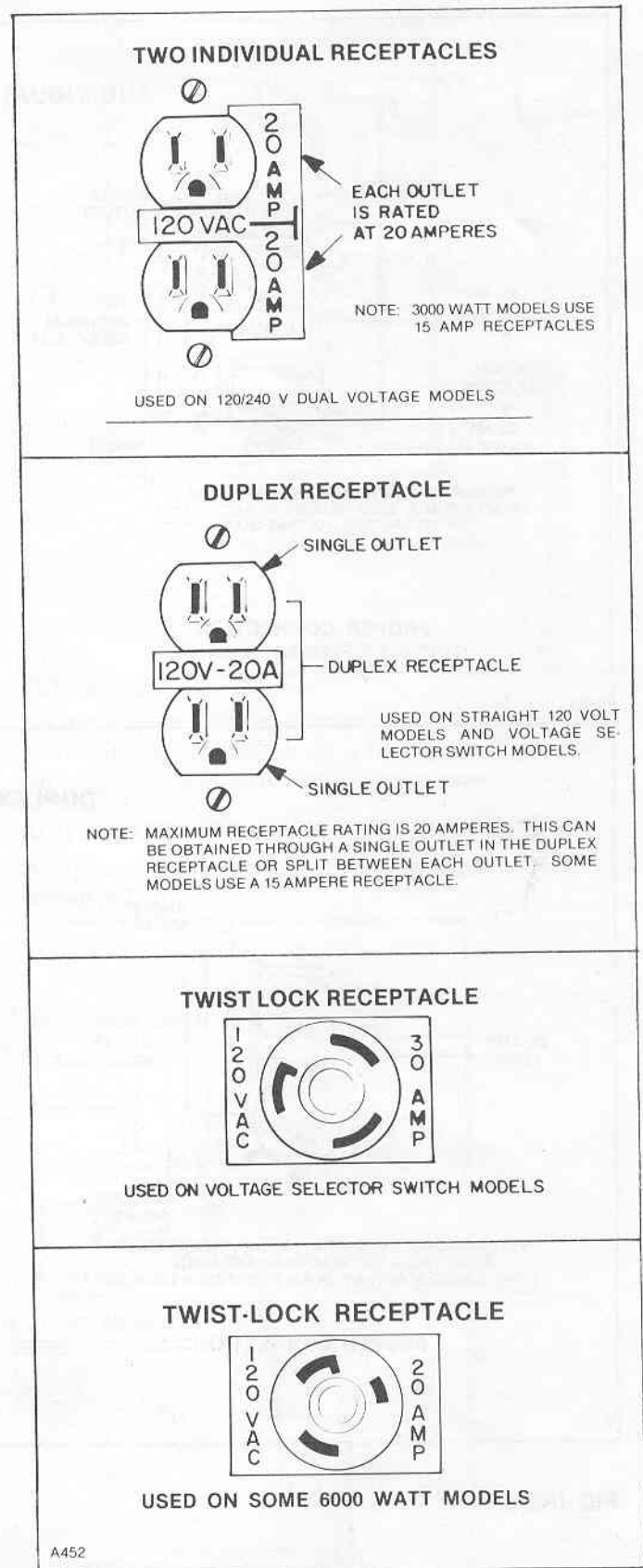

FIGURE 8

# OUTPUT RECEPTACLE CONFIGURATIONS

## 120-VOLT SINGLE VOLTAGE MODELS

### 1250 and 2000 Watt Models

These models feature a single duplex 15-ampere, 120-volt three-prong grounded receptacle. See figure 9. C.S.A. (Canadian Standards Association) modified models feature two individual 15-ampere, fused 120-volt three-prong grounded receptacle.

## 120-VOLT SINGLE VOLTAGE MODELS

### 3000, 4500, and 6000 Watt Models

These models feature two duplex 20-ampere, 120-volt three-prong grounded receptacles. See figures 10 and 10.1. C.S.A. (Canadian Standards Association) modified models feature two individual 15-ampere, fused 120-volt three-prong grounded receptacles. The 6000 watt models also include a 30-ampere, 120-volt three-prong grounded twist lock receptacle.

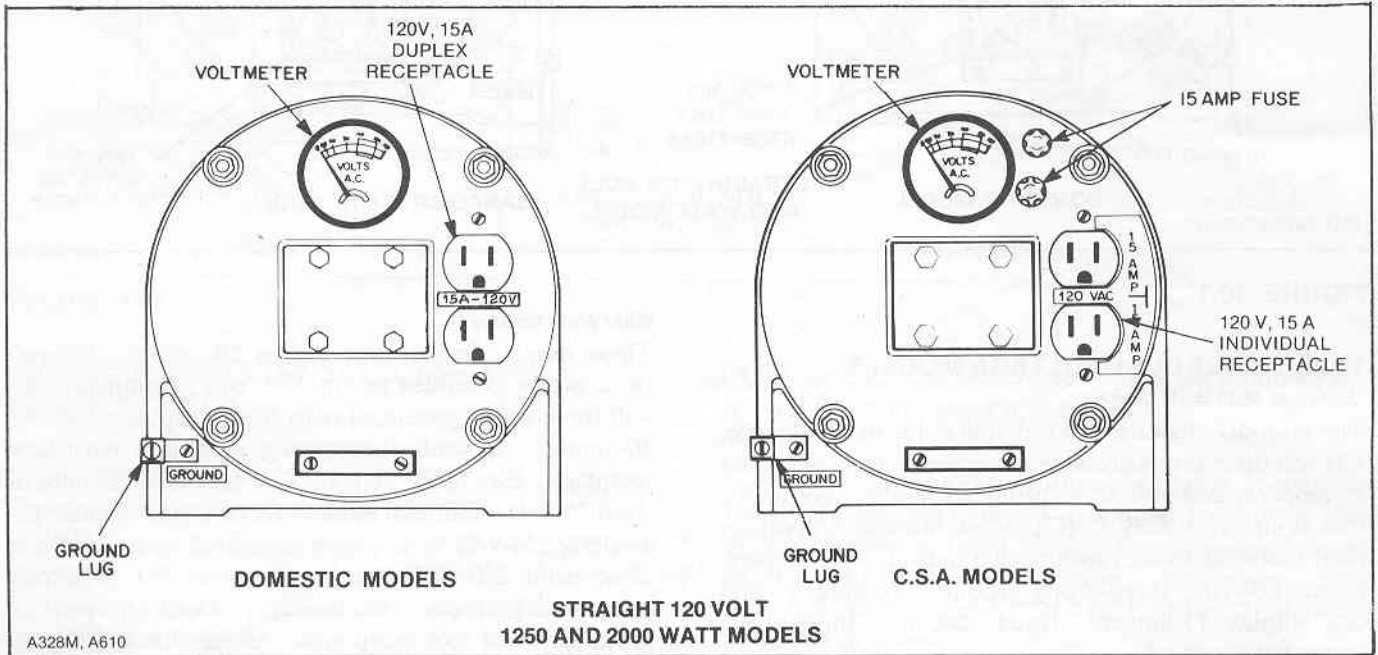

FIGURE 9

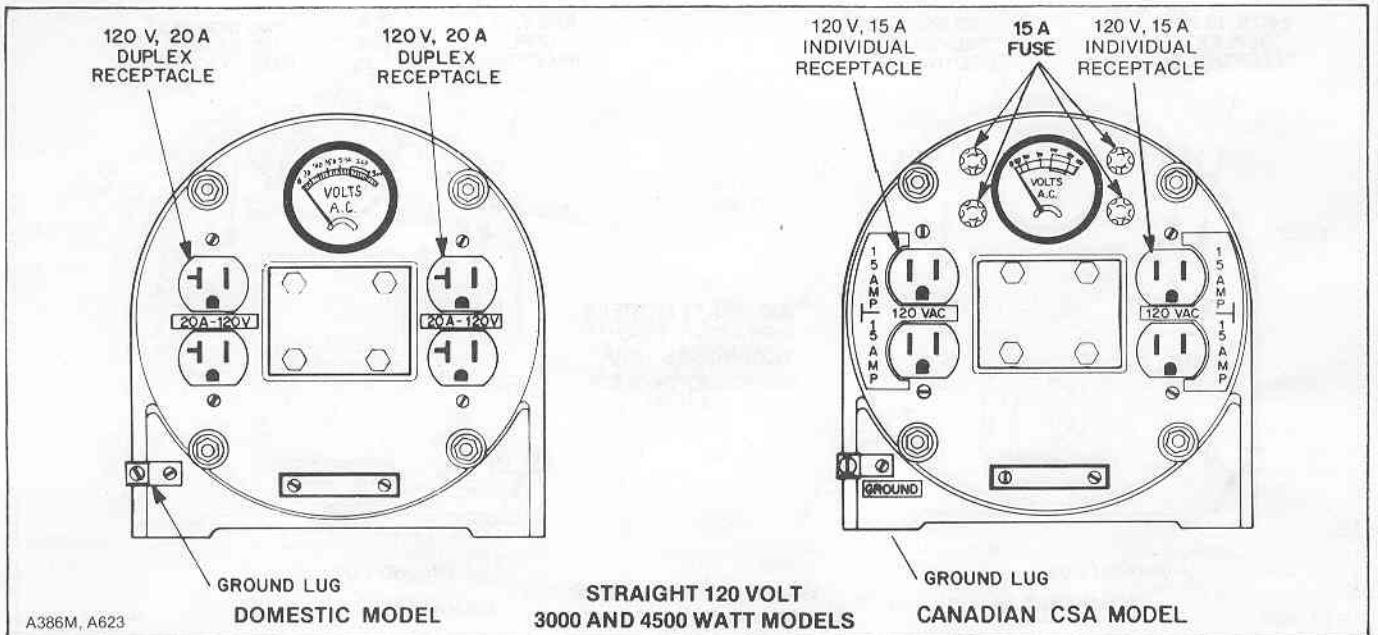
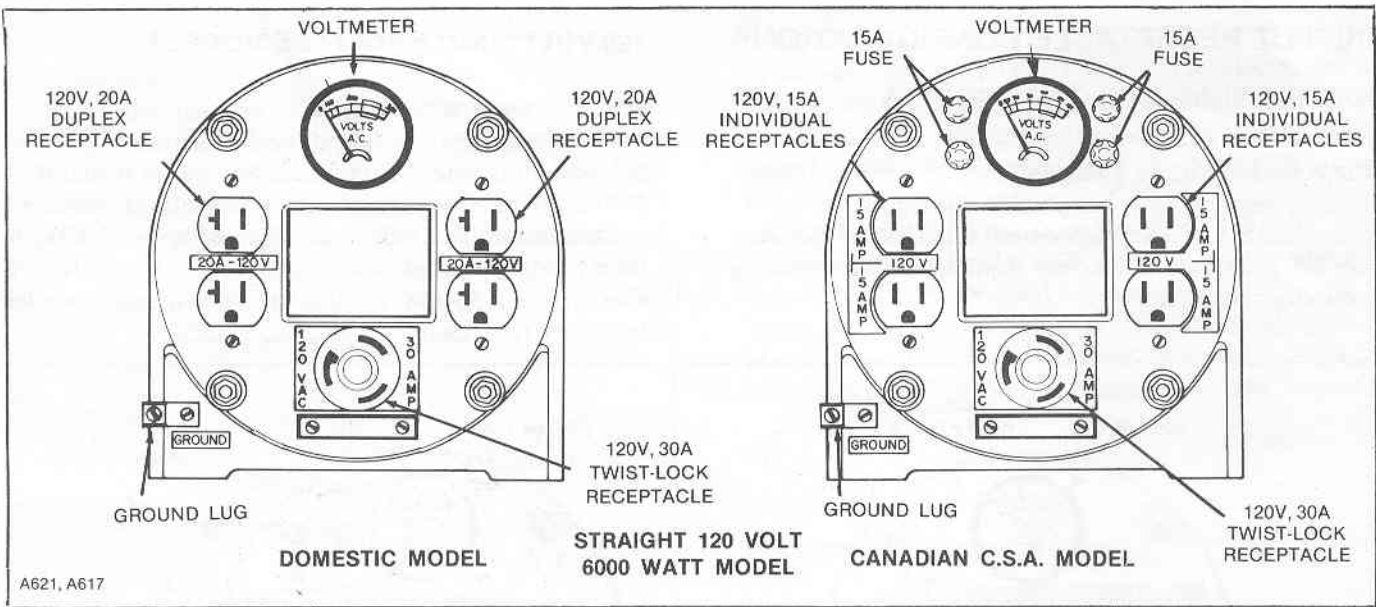

FIGURE 10



**FIGURE 10.1**

**120/240 VOLT DUAL VOLTAGE MODELS**

**3000 and 4500 Watt Models**

These models feature two individual 15- or 20-ampere, 120-volt three-prong grounded receptacles and one duplex 15-ampere, 240-volt three-prong grounded receptacle. (See figure 11.) C.S.A. (Canadian Standards Association) modified models feature two individual 15-ampere, fused, 120-volt, three-prong grounded receptacles and one duplex 15-ampere, fused, 240-volt three-prong grounded receptacle.

**6000 Watt Models**

These models feature one duplex 20-ampere, 120-volt three-prong grounded receptacles, one 20-ampere, 240-volt three-prong grounded twist-lock receptacle and one 20-ampere, 240-volt three-prong grounded twist-lock receptacle. (See figure 11.1.) C.S.A. (Canadian Standards Association) modified models feature one duplex 15-ampere, 120-volt three-prong grounded receptacle, one 20-ampere, 240-volt three-prong grounded twist-lock receptacle and one 30-ampere, 120-volt three-prong grounded twist-lock receptacle. All receptacles are protected by individual resettable circuit breakers.

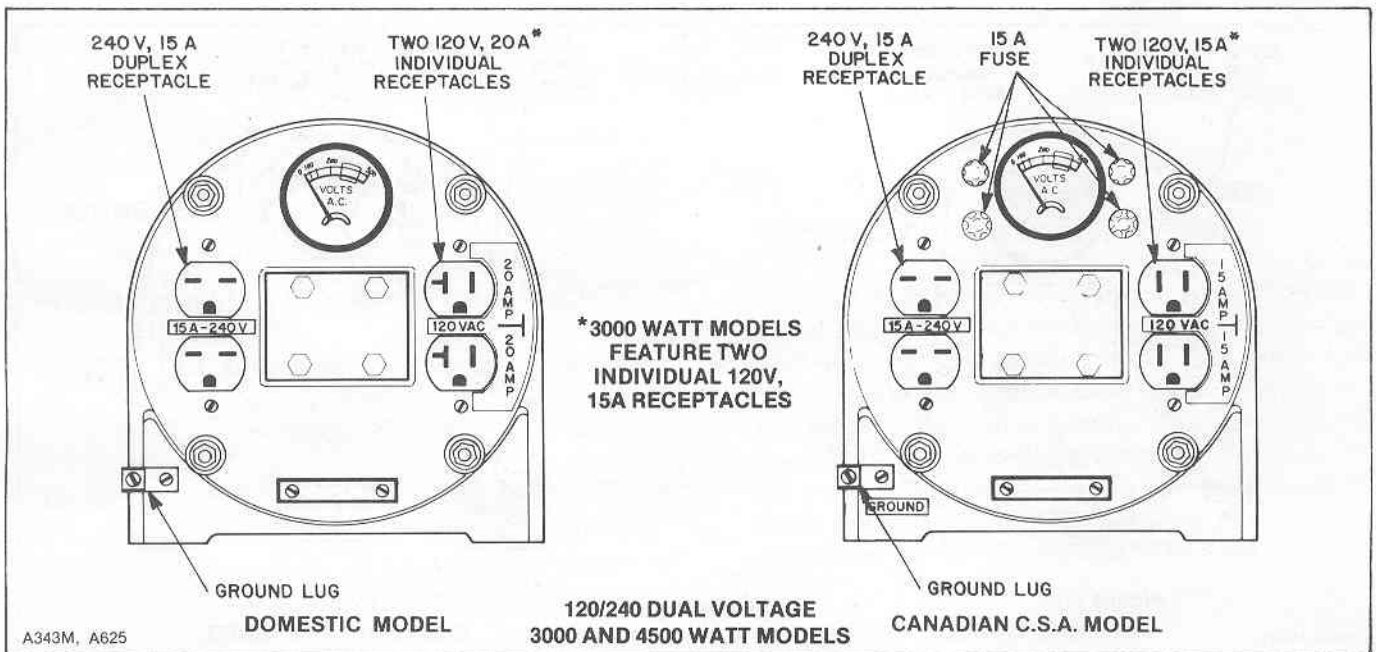

**FIGURE 11**

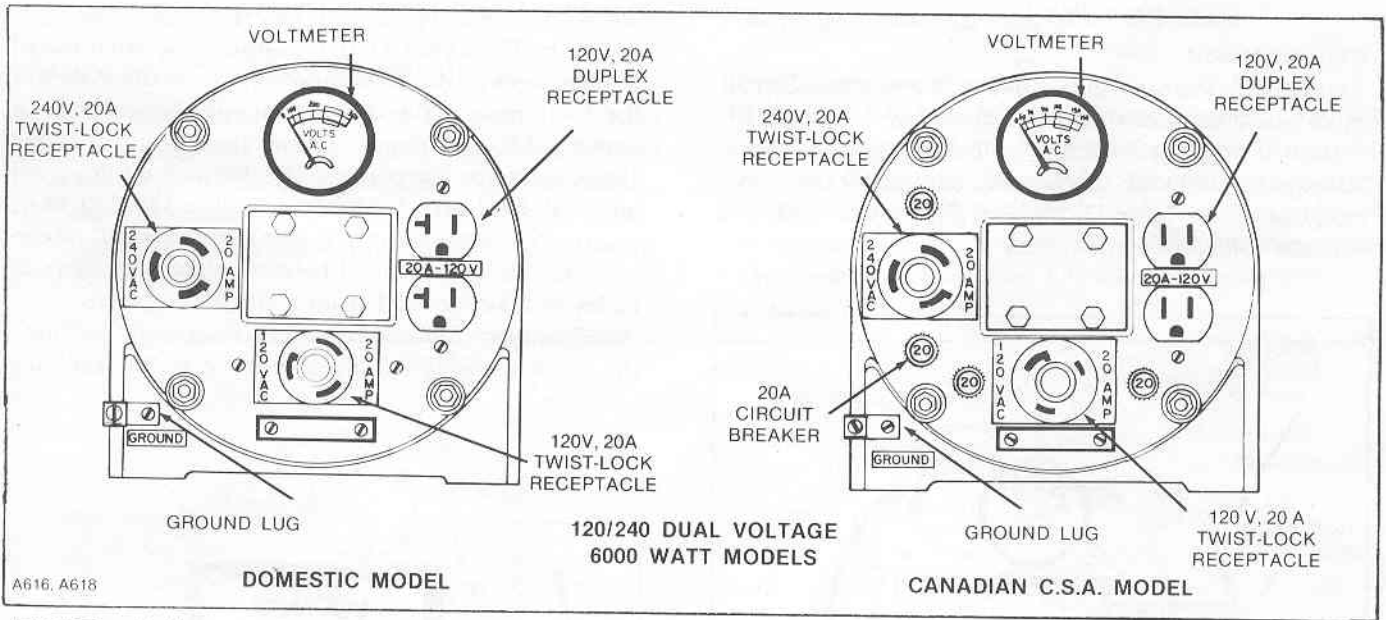

FIGURE 11.1

**120/240 VOLT VOLTAGE SELECTOR SWITCH MODELS**

**3000 and 4500 Watt Models**

These models feature one duplex 20-ampere, (15-ampere on 3000 watt models), 120-volt three-prong grounded receptacle, one duplex 15-ampere, 240-volt three-prong grounded receptacle and a 30-ampere, three-prong grounded twist-lock receptacle. (See figure 12.) A VOLT-

TAGE SELECTOR switch, see figure 13, mounted on the side of the alternator is also included.

C.S.A. modified models feature one duplex 15-ampere, fused 120-volt three-prong grounded receptacle, one duplex 15-ampere, fused 240-volt three-prong grounded receptacle and one fused 30-ampere three-prong grounded twist-lock receptacle with VOLTAGE SELECTOR switch as described below.

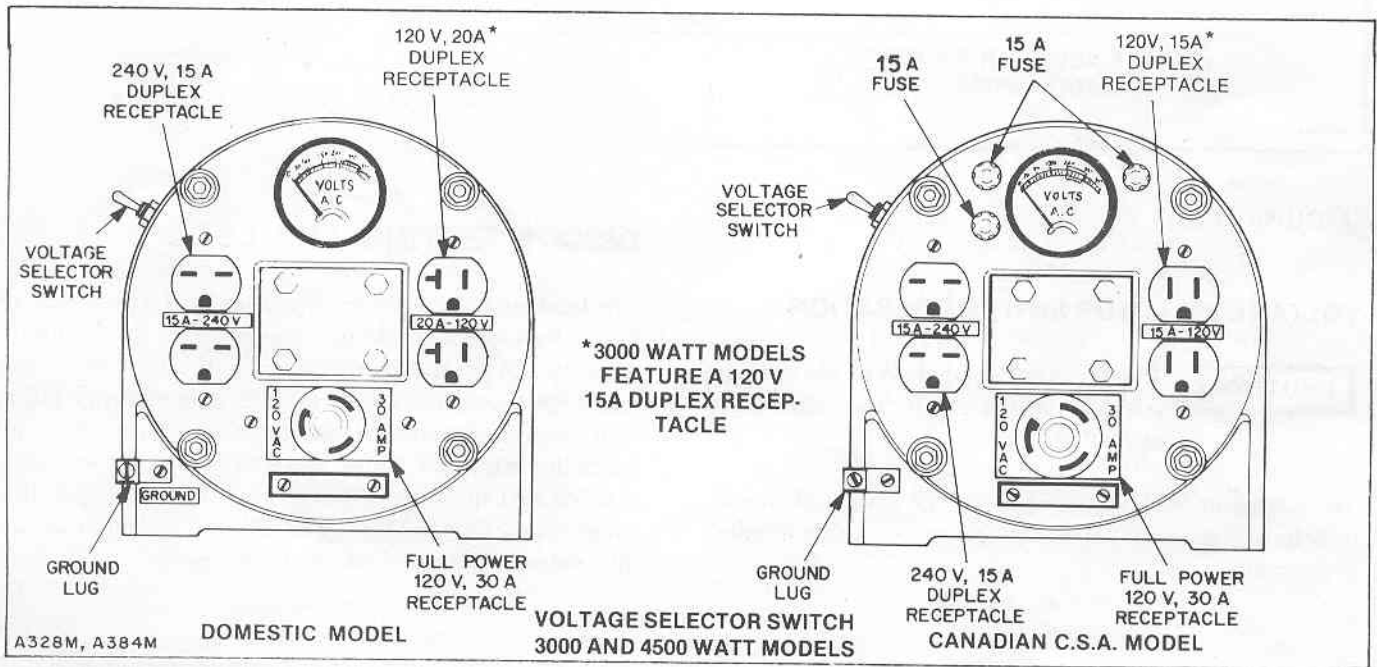

FIGURE 12

### 6000 Watt Models

This model features one duplex 20-ampere, 120-volt three-prong grounded receptacle, one 30-ampere, 120-volt three-prong grounded twist-lock receptacle and one 20-ampere, 240-volt three-prong grounded twist-lock receptacle. (See figure 12.1.) No C.S.A. model is offered with the voltage selector option.

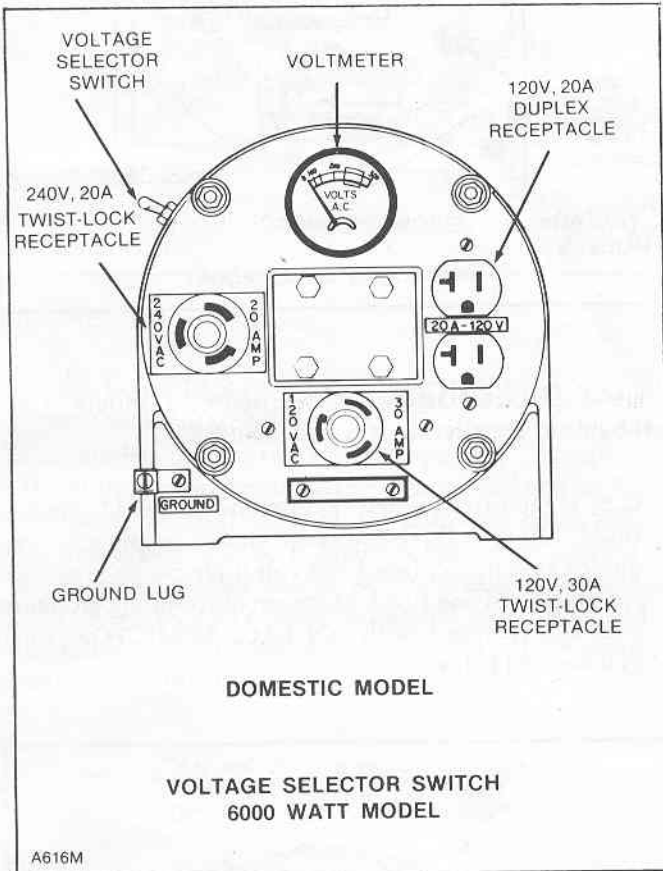

FIGURE 12.1

### VOLTAGE SELECTOR SWITCH OPERATION

**CAUTION**

Avoid changing position of the voltage selector switch with the alternator operating.

The alternator VOLTAGE SELECTOR SWITCH should only be utilized with the alternator not operating (engine shut down).

When the 120 VOLT ONLY position is selected the full wattage capacity (up to 30 amperes) can be obtained from the 30-ampere, 120-volt outlet or split between the 30-ampere, 120-volt receptacle and the 15- or 20-ampere 120-volt duplex receptacle. The 240 volt duplex receptacle will be dead. In the dual voltage 120/240 VOLT position the 30-ampere, 120-volt receptacle will be dead but you can split the load between all remaining receptacles or take the load from a single receptacle (except the 30-ampere 120-volt twist-lock receptacle) as long as the ampere rating of the receptacle is not exceeded.

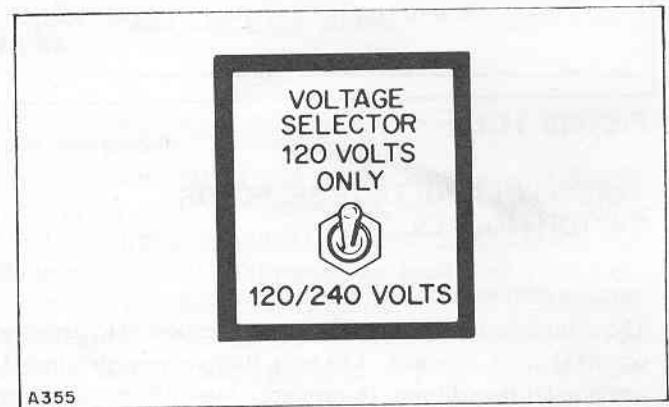

FIGURE 13

### DISCONNECTING THE LOAD

The load should be removed gradually. Large motor or power tool loads should be removed first. If this unit is used on a lawn and garden tractor, the tractor throttle might have to be reduced as large electric motor or power tool loads are reduced to keep the voltmeter needle from exceeding the color coded green operating range. Output voltages in excess of the top of the green operating range could damage the items still left powered by the alternator, such as TV sets, light bulbs, etc.

## OPTIONAL EQUIPMENT

### OPTIONAL TWIST LOCK RECEPTACLE

If this alternator is equipped with optional three-prong grounded, twist-lock duplex receptacles it is important to note that they are rated at 15 amperes for both the 120- and 240-volt receptacles (See figure 14.). C.S.A. models if equipped with twist-lock receptacle, will be fused. The 30-ampere, 120-volt receptacle included as standard on VOLTAGE SELECTOR switch models is of the the three-prong twist-lock type. Regardless of receptacle type do **not** exceed its ampere rating.

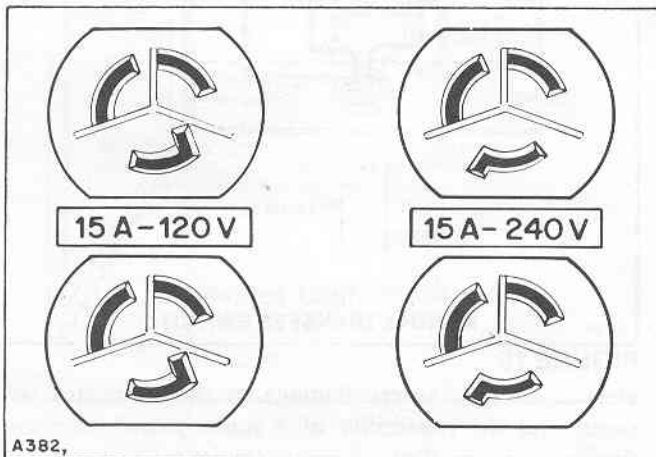

FIGURE 14

### OPTIONAL FUSED OUTLET RECEPTACLES

C.S.A. modified models are equipped with either fuse-protected receptacles or circuit breaker protected receptacles as standard equipment. This is an optional acces-

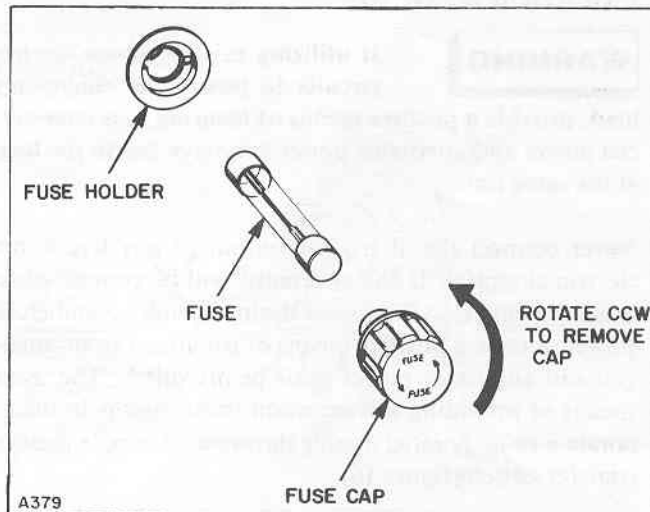

FIGURE 15

sory on domestic models. If a fuse blows, or circuit breaker opens, it is an indication that the receptacle is being overloaded. Only replace fuses with a fuse of the same amperage rating (15 amperes). Replacement fuses can be purchased locally from any hardware, electric wholesale, automotive supply or electronic supply house.

To replace fuse press down on fuse holder cap and turn counterclockwise (See figure 15.). Remove fuse holder cap, replace fuse and replace fuse holder cap by pressing down on cap while rotating clockwise to lock cap in place.

Fusing is only available factory installed and is not available as a customer installed field conversion kit.

## HOME STAND-BY INSTALLATIONS

This alternator does not have the output capacity to power your entire home. Most home utility commercial electric service is in excess of 60 amperes which will **exceed** the output of this alternator. Because of this only key items can be powered (up to the ampere rating of the alternator) during a utility power outage.

### INSTALLATION METHOD WITHOUT EXTENSIVE HOME REWIRING

If expensive home rewiring for a permanent standby installation is not desired this alternator can be utilized in a power outage by plugging appliances, furnace blowers, sump pumps and other items to be powered during the emergency directly into the alternator output recep-

tacles. Do not exceed the ampere rating of the alternator and the receptacles and only use three-prong grounded plugs.

### INSTALLATION METHODS UTILIZING EXISTING ELECTRIC CIRCUITS

**NOTE** Any permanent wiring installations must comply with the National Electric Code, and all local and state codes. Consult a qualified licensed electrician or electrical contractor.

#### **WARNING**

Installing and wiring a home stand-by alternator system using existing home electric circuits *is not* a do-it-yourself project. Consult a qualified licensed electrician or electrical contractor.

## ALTERNATOR AND UTILITY POWER ISOLATION METHODS

### WARNING

If utilizing existing home electric circuits to power the emergency load, provide a positive means of insuring that commercial power and alternator power are *never* fed to the load at the same time.

Never connect the alternator output to any live home electric circuit(s). If the alternator will be connected to existing home electric circuits during a utility commercial power outage, a positive means of isolating the commercial and alternator power must be provided. The usual means of providing this isolation protection is to incorporate a suitably rated double throw, double pole manual transfer switch (figure 16).

A potential hazard exists during a power outage if the alternator output is connected to the dead home electric circuits and no means is provided to isolate the home electric circuits from the commercial power source. A power company lineman working to return the electric service to normal will open a switch between the main power supply and the spot where he is working. He has every right to believe that the line is dead. If the home electric circuits are not isolated the alternator output will backfeed through the home electric circuits up to the power line and the line repairman may be electrocuted when he attempts repairs. If normal power and alternator power are not isolated and the normal power is suddenly restored while the alternator is still powering the home

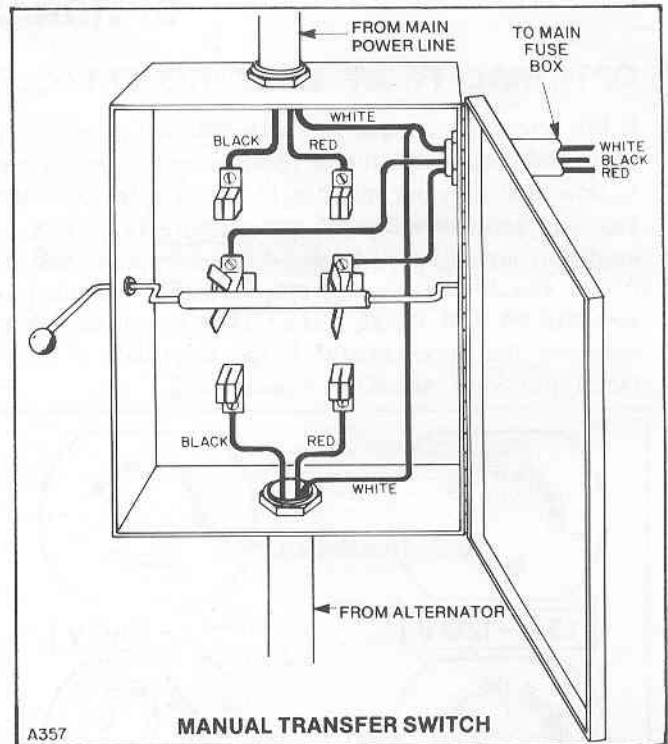

FIGURE 16

electric circuits, severe damage to the alternator will occur and the possibility of a home electric fire and damage to home electric wiring circuits exist.

### SUGGESTED HOME REWIRING METHODS

A typical installation with a manual transfer switch is shown in figure 17.

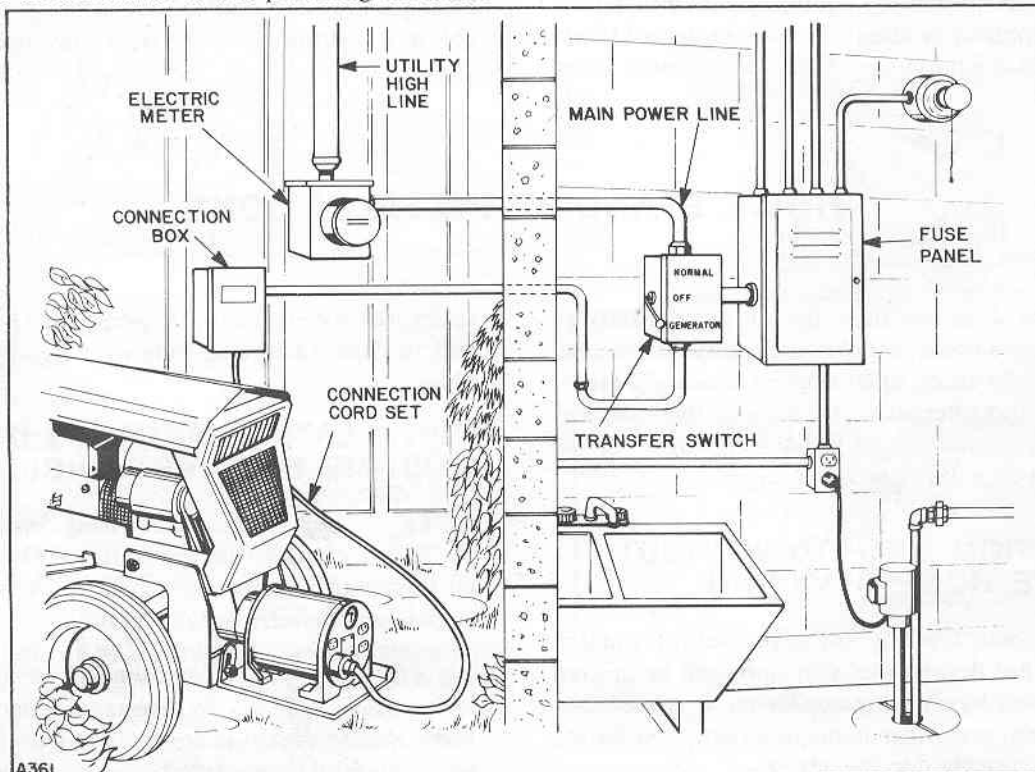
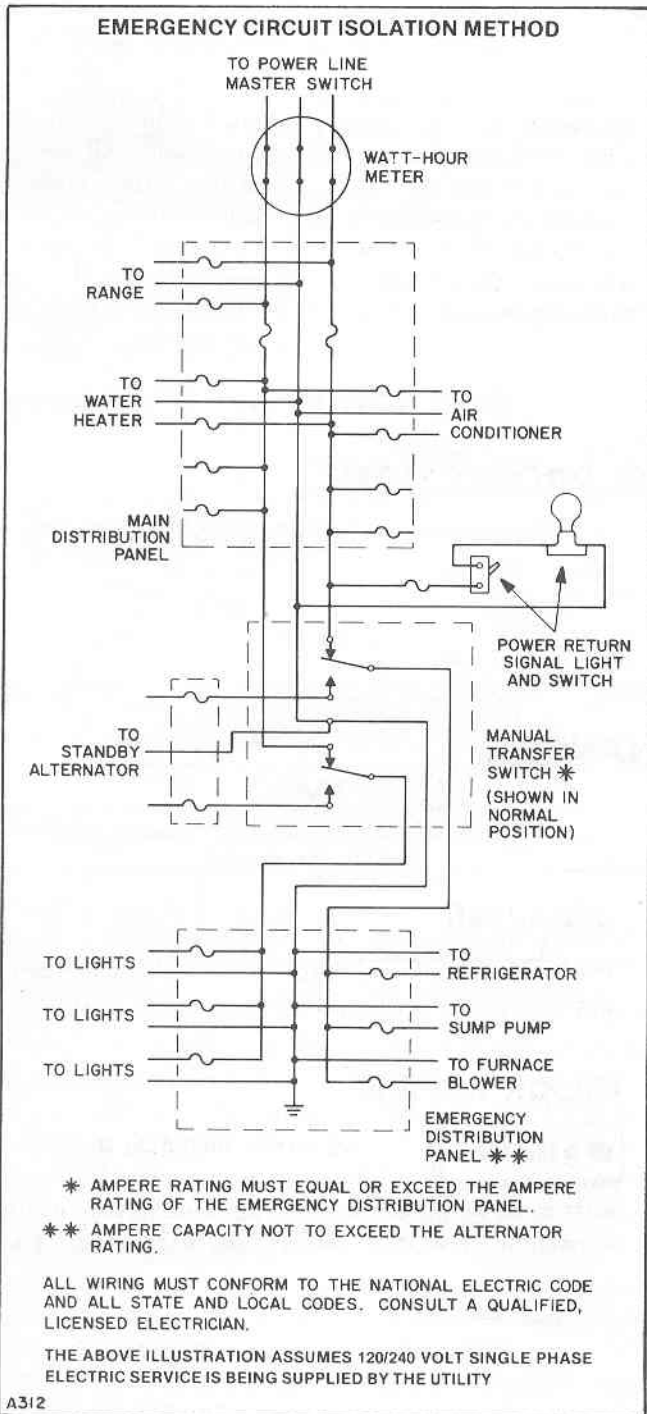

FIGURE 17





**FIGURE 18**  
**EMERGENCY CIRCUIT ISOLATION METHOD**

One method is that the emergency circuits (important items to be powered in a power outage) be grouped together and rewired into a separate junction box (this emergency circuit must **not exceed** the ampere rating of the alternator) and connected to the alternator by a cord set or directly wired into the alternator. The manual transfer switch with an ampere rating equal to the ampere rating of the emergency circuit, would then be connected between the home load center panel and the emergency

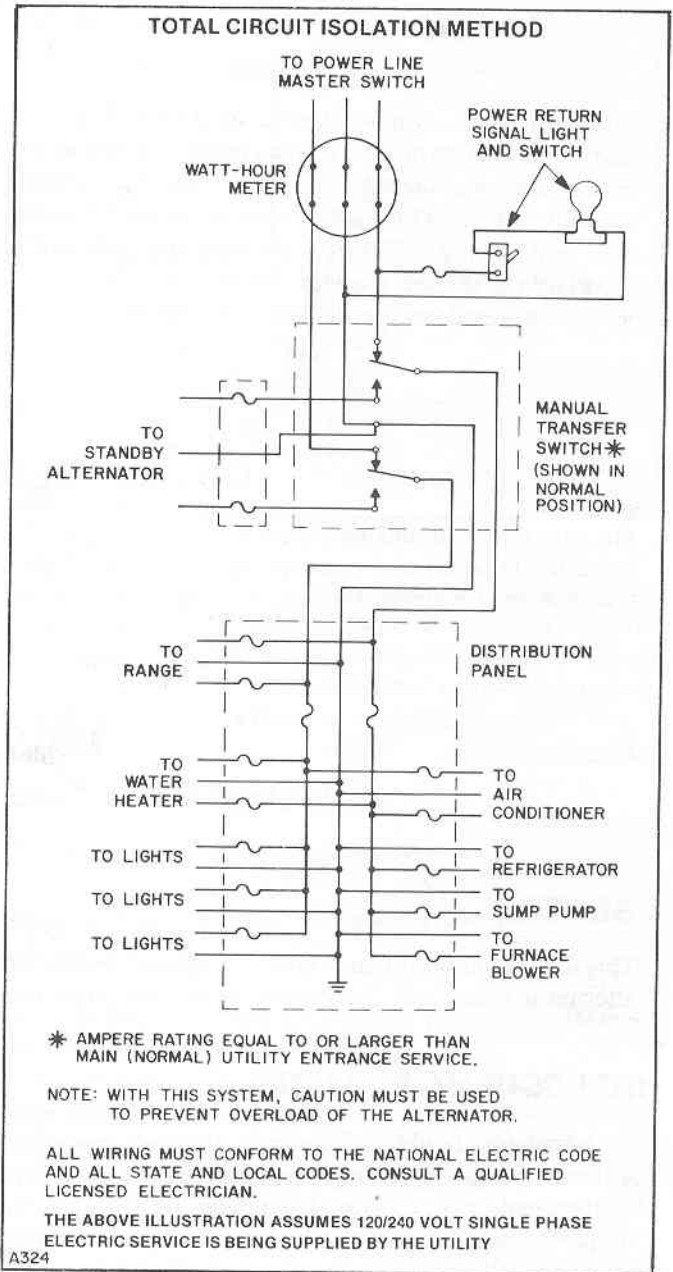

**FIGURE 19**

circuit junction box (fig. 18). With this method it will be difficult to accidentally overload the alternator. During a power outage start the alternator (with no load) and then place the manual transfer switch in the generator position. The emergency circuits will now be powered by the alternator. When the normal power is restored the manual transfer switch should be placed in the normal position after the alternator is shut down. The emergency circuits will now be powered by the normal power source.

**TOTAL CIRCUIT ISOLATION METHOD**

If the emergency circuits are not or cannot be rewired together in a separate junction box (fig. 19), you will have to select the circuits and appliances to be powered by the

alternator. Caution must then be used to prevent overload of the alternator. The manual transfer switch ampere rating must equal the ampere rating of the normal incoming utility service. During a power outage start the alternator with no load. All items in the home should be turned off. Place the manual transfer switch in the "generator" position. Selected emergency items can then be turned on.

Be sure these items don't overload the alternator. The emergency items left on the home circuits will now be powered by the alternator. When the normal power is restored the manual transfer switch should be placed in the "normal" position after the alternator is shut down. The home electric circuits will now be powered by the normal power source.

## OUT OF SERVICE PROTECTION

The alternator should be covered and stored in a dry protected location and **not** exposed to extreme high or low ambient temperatures during storage. A light coat

of protective oil should be applied to the output shaft to prevent rusting.

## MAINTENANCE

### GENERAL

This unit requires no maintenance except for keeping the alternator clean and the output shaft free from rust.

### INFREQUENT SERVICE

The alternator should be frequently operated, every four or five weeks to keep corrosion and moisture on the D.C. brushes, collector rings and windings to a minimum. Frequent operation will also insure that the unit is operating correctly and ready for use in an emergency.

### BEARINGS

The bearings are heavy duty lifetime sealed ball bearings and require no maintenance or lubrication.

### MAJOR REPAIR

#### **WARNING**

**All service including the installation or replacement of service parts must be performed only by a qualified electrical serviceman. Use only factory approved repair parts.**

## WATTAGE REQUIREMENTS

### Typical power loads that these various alternator models can operate

1250 watt	House lights	½-HP furnace fan	Refrigerator				
2000 watt	House lights	½-HP furnace fan	Refrigerator	½-HP sump pump			
3000 watt	House lights	½-HP furnace fan	Refrigerator	½-HP sump pump	Freezer		
4500 watt	House lights	½-HP furnace fan	Refrigerator	½-HP sump pump	Freezer	Television	
5500 watt	House lights	½-HP furnace fan	Refrigerator	½-HP sump pump	Freezer	Television	Stove (1 burner)

### Recommend Minimum Wire Gauges for Extension Cords for Portable Electric Tools

Ampere Rating	Length of Cord in Feet		
	50	100	150
2	18 GA	18 GA	18 GA
3	18 GA	18 GA	18 GA
4	16 GA	16 GA	16 GA
5	16 GA	16 GA	16 GA
6	16 GA	16 GA	14 GA
8	16 GA	14 GA	12 GA
10	16 GA	14 GA	12 GA
12	14 GA	14 GA	12 GA
14	14 GA	12 GA	10 GA
16	12 GA	12 GA	10 GA

### Important facts and information on how to determine the load your alternator will handle . . . .

When determining the alternator load, it is critical for you to decide what equipment and/or appliances you want to operate at the same time. The following 5-step method will help you determine what size load this alternator can power. This procedure will help you avoid the mistake of choosing a load that exceeds the capacity of the alternator. Electric motors present a special problem when figuring the proper alternator size, so please read step 3 very carefully.

### Here's how to determine the load . . .

1. Make two lists, one of the electric motors, and the other of all the lights, small appliances, etc. that must be powered by the portable alternator. For stand-by emergency service you should only include the essential equipment (refrigerator, sump pump, etc.) which must be kept in operation.
2. Enter the watts required to operate each item (except motors, see step 3). This wattage figure can usually be found on the light bulb or appliance nameplate. If the wattage is not listed, you can determine the wattage by multiplying the amperage by the voltage (both figures are found on the appliance nameplate). NOTE, the formula for finding wattage is: Voltage X amperage = wattage.
3. Electric motors present a special problem. They usually require 2 to 3 times their nameplate amperage or wattage to start them from a locked rotor condition (motor is completely stopped). For example: If the electric motor's nameplate states 10 amps at 120 volts, the  $10 \times 120 = 1200$  watts running. This figure has to be multiplied by 3 times to figure the starting watts needed. In this example that would be 3600 watts. This starting watts figure is the one that must be used, not the nameplate or running watts figure, when figuring the load to be powered by the alternator.

NOTE: Some motors, such as those used in saws, drills, hair dryers, food mixers, etc. require approximately the same wattage to run as to start. See chart below for some examples or check appliance nameplate for wattage.

4. Add the watts required for those items in Step 1 to the starting wattages of the motors determined in Step 3.

5. Add 15% to 20% to the total wattage you determined in Step 4 to cover forgotten items. Special Notes: If more than one motor is to be started, start one motor at a time and always start the largest first. If trying to take the entire load of the alternator from a single alternator receptacle, be sure the ampere rating of the receptacle is not being exceeded.

### Typical Motor Wattages

For motor-driven electric appliances and equipment such as refrigerators, washing machines, air conditioners, pumps, oil burners, furnace blowers, barn cleaners, sump pumps, check the typical motor wattage requirements listed in chart below.

Motor HP Rating	Approx. Running Watts	Approximate Starting Watts*			
		Universal Motors (small appliance)	Repulsion Induction Motors	Capacitor Motors	Split Phase Motors
¼	275	400	600	850	1200
½	400	500	850	1050	1700
¾	450	600	975	1350	1950
1	600	750	1300	1800	2600
1½	850	1000	1900	2600	X
2	1000	1250	2300	3000	X
3	1600	1750	3200	4200	X
4	2000	2350	3900	5100	X
5	3000	X	5200	6800	X

X—Motors of higher horsepower are not generally used.

\*—Always use starting watts, not running watts, when figuring correct load.

### Typical Electric Appliance Wattages

Equipment	Watts
½-in. drill	1000
6-in. hand saw (elec.)	800
14-in. chain saw	1100
Radio	50 to 200
Television	200 to 500
Toaster, Coffeemaker	1200
1-in. elec. drill	1100
10-in. hand saw (elec.)	2000
Water heater (storage type)	1100 to 5500
Hot plate or range (per burner)	1000
Elec. range oven	10,000
Elec. skillet	1200
Fan	50 to 200
Flood light	1000
Water Pump *	500
Vacuum cleaner	200 to 300
Refrigerator (conventional) *	200 to 300
Refrigerator (freezer-comb.) *	250 to 600
Furnace fan (blower) *	500 to 700

\* Use information found in Typical Motor Wattages paragraph to find exact starting wattage.

These symbols in this manual alert you to possible hazards that could cause either personal injury or damage to the alternator.

## WARNING

The use of this symbol throughout this manual warns of possible personal injury.

## CAUTION

This symbol refers to possible unit damage.

# SAFETY FIRST!

While safety is built into every alternator set, imprudent operation, negligent maintenance or carelessness can contribute to present serious hazards to life and limb.

Gasoline and other fuels always present a hazard of possible explosion or fire.

- Keep fuel containers out of reach of children.
- Do not fill fuel tank when engine is running or hot or in the dark.
- Do not smoke or use open flame near the alternator set or fuel tank.
- When fueling electric start models do not touch battery cables or posts with a gasoline supply can.
- Keep a fire extinguisher nearby. Know its proper use. Consult your local fire department for correct extinguisher type.
- Store only in approved containers and in a well ventilated area.

Exhaust fumes are poisonous if inhaled.

- Be sure the alternator is well ventilated.
- Provide adequate ventilation for the prime mover if it is a gasoline or diesel engine or a lawn and garden tractor.

The output power voltage present in this equipment can cause a fatal electric shock. This equipment must only be operated by a responsible adult.

- Do not allow anyone to operate the alternator without proper instruction.
- Guard against electric shock.
- Avoid contact with live terminals or receptacles.
- Use extreme care if operating this unit in rain or snow.
- Only use three prong grounded receptacles and extension cords.
- This unit must be properly grounded.
- On construction sites a customer supplied GFCI (Ground Fault Circuit Interruptor) should be utilized to protect the 120-VAC receptacles.

When utilizing a lead acid starting battery on electric start models extreme care must be taken when handling or servicing the battery.

- The area must be well ventilated. Lead acid batteries emit a colorless explosive hydrogen gas when being charged.
- Do not smoke while servicing the battery. An open flame can cause an explosion.
- Do not disconnect battery cables on electric start models from battery or engine while the unit is cranking or running. Sparks may cause an explosion.
- Only operate this equipment in a well ventilated area.

- Battery acid will cause severe burns and eye damage. Use extreme care when handling or servicing the battery.

Hot engine parts, moving parts and the output of the alternator set could cause serious injury to the operator. The operator must use caution and remain alert when using this unit.

- All pulleys, belts, etc. should be provided with safety guards.
- Keep all safety guards and power shields in position and tightly secured.
- When working on or around this unit do not wear neckties or loose shirts, jackets, or sleeves that may become caught in moving parts.

Only a qualified technician should perform repairs on this equipment.

- Do not work on this equipment when fatigued.
- Use extreme caution when working on electrical components. High output voltages from this equipment can cause injury or death.
- When working on this equipment avoid hot mufflers, exhaust manifolds, and engine parts which can cause severe burns.

Installing and wiring a home-standby alternator installation *is not* a do-it-yourself project. Consult a qualified licensed electrician or contractor.

- The installation must comply with all national, state and local codes.

Excessive noise is not only tiring but continual exposure can lead to loss of hearing.

- When working around engines or tractors use the best noise suppression equipment and wear protective devices as necessary.
- Keep your neighbors in mind when noise level is high.

Keep the alternator and surrounding area clean.

- Remove all grease, ice, snow or materials that create slippery conditions around the unit.
- Remove oily rags and other material that create potential fire hazards. Keep a fire extinguisher nearby.
- Extinguishers rated ABC by the NFPA are appropriate for all applications. Consult the local fire department.
- Keep extinguisher properly maintained and be familiar with its proper use.

The manufacturer recommends that all service including the installation or replacement of service parts be performed only by a qualified electrical serviceman. Use only factory approved repair parts.

# PARTS CATALOG

Figure 20 identifies all maintenance parts. Use the procedure shown on back cover to obtain replacement parts and service. On lawn and garden tractor models alternator mounting hitch parts information is included with the mounting hitch.

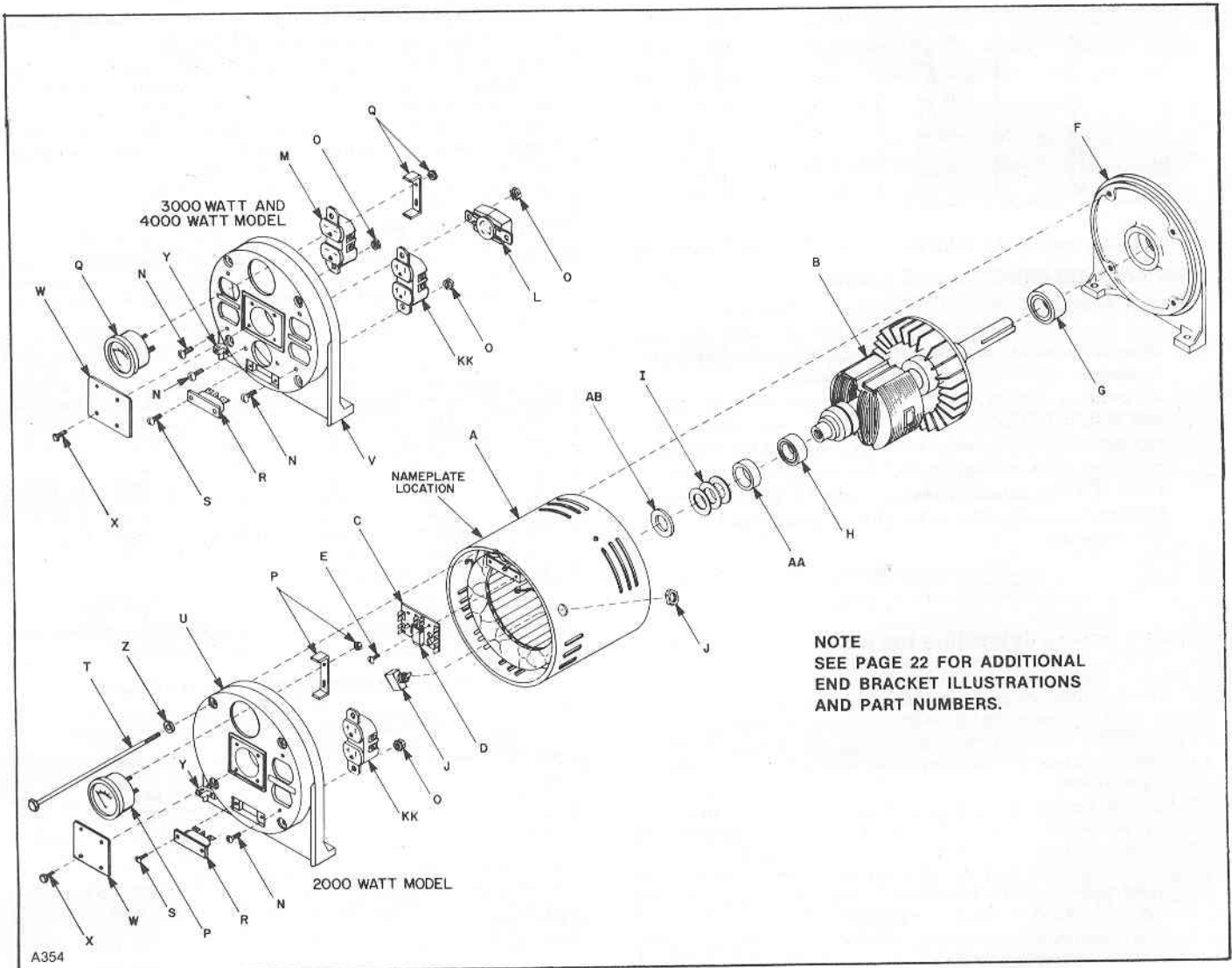

FIGURE 20

## DUAL BEARING ALTERNATORS

REF	PART NUMBER	DESCRIPTION	QUANTITY					
			1250 WATT	2000 WATT	3000 WATT	4500 WATT	6000 WATT	
A	F9500-030	Stator Assy	1					
A	F9501-032	Stator Assy		1				
A	F9502-040	Stator Assy			1			
A	F9503-041	Stator Assy				1		
A	F9548-066	Stator Assy					1	
B	A9500-035	Rotor w/Fan	1					1
B	A9501-036	Rotor w/Fan		1				
B	A9502-037	Rotor w/Fan			1			
B	A9503-038	Rotor w/Fan				1		
B	A9548-000	Rotor w/Fan					1	
B	A9501-043	Rotor w/Fan (IH Models)		1				1
B	A9502-044	Rotor w/Fan (IH Models)			1			
B	A9503-045	Rotor w/Fan (IH Models)				1		
C	X65RF024	Brush Holder Assy			1	1		1
C	X65RF026	Brush Holder Assy			1	1		
C	X65RF022	Brush Holder Assy	1	1				
D***	21826-000	Brush & Spring w/Lug	2	2	2	2		2
E	19813-000	Screw	2	2	2	2		2
F	22244-000	Bracket						1
F	21738-000	Bracket	1	1	1	1		
G	16566-000	Bearing	1	1	1	1		
G	18563-000	Bearing						1
H	15535-000	Bearing	1	1	1	1		1
J**	16528-000	Shims			As Required			
J*	19602-000	Switch w/Nut						
K	16310-000	Receptacle, Duplex 120-V, 15A	1					
KK	16378-000	Receptacle, Duplex 120-V, 20A		1	1	1		1
L	21001-000	Receptacle, Twist-Lock 120-V, 30A			1			1
M	16379-000	Receptacle, Duplex 240-V, 15A			1	1		
N	52-0008-02	Screw	2	2	6	6		6
O	22261-000	Nut	2	2	6	6		6
P	15202-000	Voltmeter, (0-150V) Brkt, Nut	1	1				1
Q	15203-000	Voltmeter, (0-300V) Brkt, Nut		1	1			1
R	21828-000	Rectifier	1	1	1	1		1
S	22164-002	Screw	2	2	2	2		2
T	21832-000	Stator Thru Bolt	4	4				
T	21862-002	Stator Thru Bolt			4			
T	21874-002	Stator Thru Bolt				4		4
U		See Table on page 22	1	1	1	1		1
W	21887-000	End Plate	1	1	1	1		1
X	21631-004	Hex Screw	4	4	4	4		4
Y	17587-000	Ground Lug	1	1	1	1		1
Z	03405-002	Lockwasher	4	4	4	4		4
AA▶	22294-000	Fuseholder						4
AB▶	19330-000	Fuse						4
AC	22430-000	Receptacle, 20A, 240-V Twist-lock						1
AD	22531-000	Receptacle, 20A, 120-V Twist-lock						1
AE	22216-002	Circuit Breaker, 20A						4

\* Used on voltage selector switch models only.

\*\*\* Supplied when ordering X65RF022.

\*\* Added as required to eliminate end play.

▶ Supplied on C.S.A. Models.

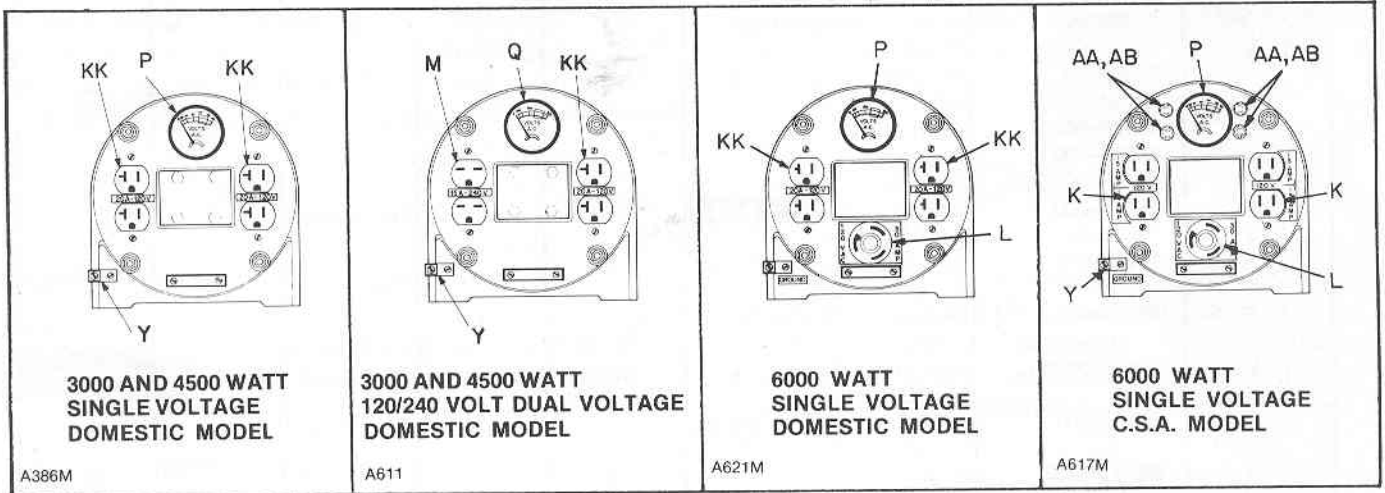
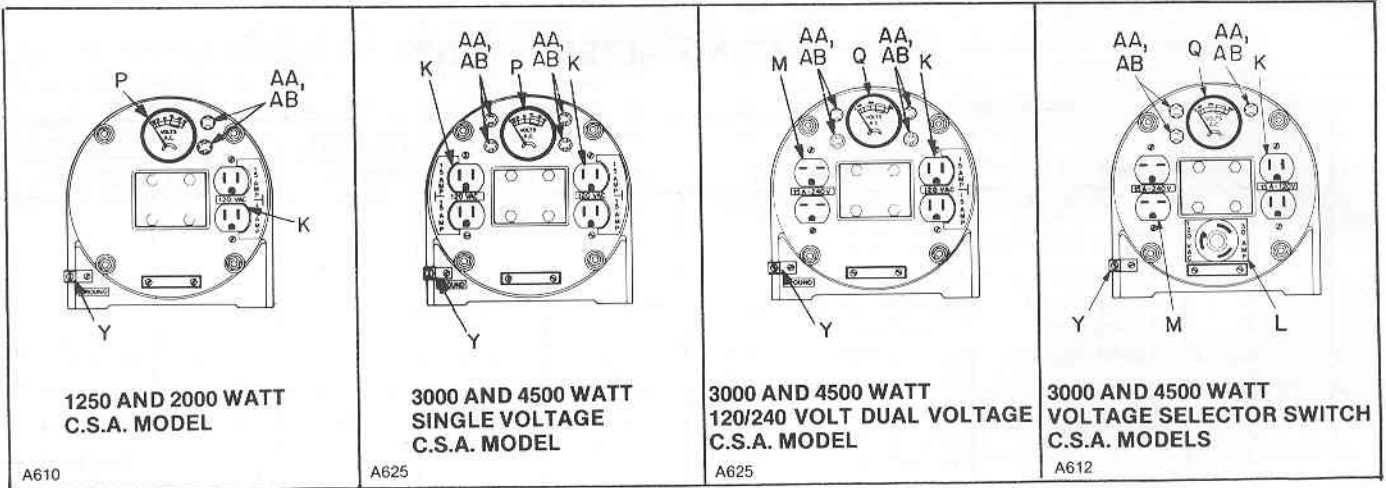

\* Use "L" on voltage selector switch models.

**6000 WATT 120/240-VOLT DUAL VOLTAGE AND VOLTAGE SELECTOR SWITCH DOMESTIC MODEL**  
A616M

**6000 WATT 120/240-VOLT DUAL VOLTAGE C.S.A. MODEL**  
A618

END BRACKET TABLE		
MODEL	END BRACKET	
	STANDARD	C.S.A.
GBRF12H1	21733-002	21733-009
GBRF20H1	21733-002	21733-009
GBRF30H1	21733-003	21733-024
GBRF30H2	21733-003	21733-024
GBRF30H5	21733-005	21733-011
GBRF45H1	21733-003	21733-016
GBRF45H2	21733-003	21733-024
GBRF45H5	21733-005	21733-004
GBRF60H1	21733-005	21733-016
GBRF60H2	21733-015	21733-017
GBRF60H5	21733-015	—

# GENERAL INFORMATION

## INSTRUCTIONS FOR ORDERING REPAIR PARTS

INFORMATION ON THIS PAGE IS INCLUDED FOR OWNERS WHO HAVE PURCHASED THE EQUIPMENT COVERED IN THIS BOOKLET.

For parts or service, contact either the factory or your nearest Authorized **PINCOR** Service Station.

To avoid errors or delay in filling your parts order, please furnish all information requested.

Always refer to the nameplate on your unit:

1. Always give the MODEL and SS(SPEC NO.) and SERIAL NO.

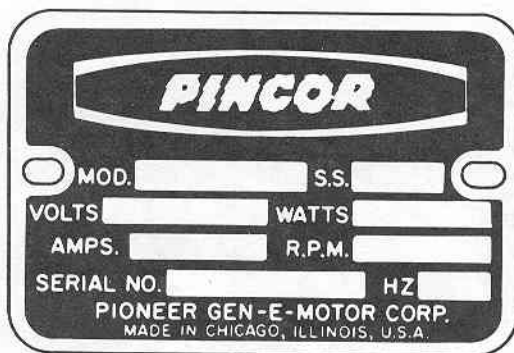

For handy reference, insert "YOUR" nameplate information in the spaces above.

2. Do not order by reference number or group number: always use part number and description.
3. Give the part number, description and quantity needed of each item. If an older part cannot be identified, return the part prepaid to your nearest **PINCOR AUTHORIZED SERVICE STATION**. Print your name and address plainly on the package. Write a letter to the same address stating the reason for returning the part.
4. State definite shipping instructions. Any claim for loss or damage to your unit in transit should be filed promptly against the transportation company making the delivery. Shipments are complete unless the packing list indicates items are back ordered.
5. Do not return parts or merchandise to the factory without receiving a **Customer Return Authorization** number from our National Service Department. All packages should have the number clearly marked on the outside of the package and the merchandise or parts being returned should be marked or tagged with this **CRA** number.

Prices are purposely omitted from this Parts Catalog due to the confusion resulting from fluctuating costs, import duties, sales taxes, exchange rates, etc.

For current parts prices, consult your nearest **PINCOR** Authorized Service Station, or the Factory.

### NOTICE!

ITEMS REFERENCED AS **OPTIONAL** USUALLY INDICATE PART IS FACTORY INSTALLED AND MAY NOT BE APPLICABLE TO ALL MODELS. FOR FIELD CONVERSIONS ADDITIONAL PARTS ARE USUALLY REQUIRED AND SOME OPTIONS CAN NOT BE CUSTOMER INSTALLED IN THE FIELD.

If this product is equipped with an engine it is not covered by **PINCOR'S** warranty. The engine is covered by the engine manufacturer warranty. Your nearest engine service center is listed in the "Yellow Pages" under "Engines, Gasoline" or "Gasoline Engines."





# TABLE OF CONTENTS

SPECIFICATIONS .....	3
GENERAL INFORMATION .....	4
ALTERNATOR DESCRIPTION .....	4
OPERATION .....	4
OPTIONAL EQUIPMENT .....	15
HOME STANDBY INSTALLATIONS .....	15
OUT-OF-SERVICE PROTECTION .....	18
MAINTENANCE .....	18
WATTAGE REQUIREMENTS .....	19
PARTS CATALOG .....	20

## MODEL NUMBERING SYSTEM

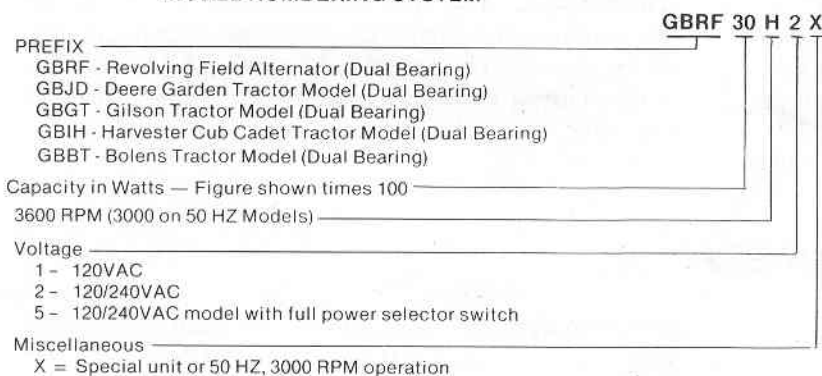

## PHYSICAL SPECIFICATIONS

CAPACITY IN WATTS	NET WEIGHT (POUNDS)	DIMENSIONS (INCHES)		
		L*	W	H
1250	46	9.50	8-1/2	8-3/4
2000	48	9.50	8-1/2	8-3/4
3000	56	10.94	8-1/2	8-3/4
4500	76	12.83	8-1/2	8-3/4
6000	88	13.13	8-1/2	8-3/4

\* Does not include 2.50 inch shaft length. Shaft length is 2.75 on GBIH series alternators.

## ELECTRICAL SPECIFICATIONS

(ALL UNITS ARE 3600 RPM, 60 HZ)

MODEL NO.*†	WATTS	VOLTS	AMP		TWIST LOCKS			SINGLE OUTLETS		DUPLEX OUTLETS			VOLTAGE SELECTOR SWITCH
			120 V	240 V	120 V	120 V	240 V	120 V	120 V	120 V	120 V	240 V	
					20 A	30 A	20 A	15 A	20 A	15 A	20 A	15 A	
GBRF12H1	1250	120	10.4	—	—	—	—	—	—	1	—	—	—
GBRF20H1	2000	120	16.7	—	—	—	—	—	—	—	1	—	—
GBRF30H1	3000	120	25.0	—	—	—	—	—	—	—	2	—	—
GBRF30H2	3000	120/240	25.0	12.5	—	—	—	2	—	—	—	1	—
GBRF30H5	3000	120/240	25.0	12.5	—	1	—	—	—	1	—	1	Standard
GBRF45H1	4500	120	37.5	—	—	—	—	—	—	—	2	—	—
GBRF45H2	4500	120/240	37.5	18.8	—	—	—	—	2	—	—	1	—
GBRF45H5	4500	120/240	37.5	18.8	—	1	—	—	—	—	1	1	Standard
GBRF60H1	6000	120	50.0	—	—	1	—	—	—	—	2	—	—
GBRF60H2	6000	120/240	50.0	25.0	1	—	1	—	—	—	1	—	—
GBRF60H5	6000	120/240	50.0	25.0	—	1	1	—	—	—	1	—	Standard

\* All lawn and garden tractor models 3000 watts and above include the full power selector switch option. Consult the separate instruction sheet included for parts information on the tractor hitch for alternator mounting. A complete mounting hitch is included along with a V-belt and pulley on the GBIH, GBJD, GBBT, and GBGT Series alternators.

† C.S.A. (Canadian Standards Association) models include either fused or circuit breaker protected output receptacles as standard equipment.

▶ See page 14 of this manual for a complete description of the voltage selector switch.

◀ See page 9 of this manual for a complete description of the unit mounted receptacles.

## GENERAL INFORMATION

This dual bearing extended shaft electric alternator is rugged, lightweight, compact, and designed for dependable, trouble-free operation. It will provide years of reliable service if given the proper care. This manual contains information for the proper installation, operation, and maintenance of the alternator. Study the informa-

tion in this manual carefully before attempting to operate the alternator. Keep the manual in a convenient location and refer to it often for operation and maintenance instructions. On garden tractor models a separate instruction sheet and parts list is included which covers the lawn and garden tractor alternator mounting platform.

## ALTERNATOR DESCRIPTION

This dual bearing, extended shaft alternator is two pole revolving field in construction. It is designed for rotation in either direction (clockwise or counterclockwise) through a V-belt drive at a constant speed of 3600 RPM (3000 RPM for 50 Hertz export models) to produce the rated voltage as shown on the unit nameplate. The alternator is designed with a self-excited revolving field (rotor). The stationary armature (stator) contains three windings: two 120-volt AC windings that supply AC power directly to the load, and a single exciter winding. Permanent magnets in the two field poles (rotor) when rotated in the stator cause an AC current to be generated in the stator exciter winding and two load windings. The AC current

generated in the stator exciter winding is rectified by a solid state rectifier (diode) module to produce a DC current. This DC current passes through low current brushes and slip rings back to the rotor which results in stronger magnetic field current flow than the original rotor residual magnetism. A stronger rotor field current creates a greater current flow (alternator output) in both the stator AC load windings. This cycle is constantly repeated until the pre-determined AC current flow (load output capacity of the alternator) is reached. The output of the alternator is taken directly from the stator load windings through the outlet receptacles in the unit end bell.

## OPERATION

Consult this owners guide frequently.

### WARNING

**This alternator should only be operated by a responsible adult.**

## VISUAL INSPECTION

Visually inspect the unit before the initial start. Check for loose or missing parts and any damage that may have occurred in shipment. If the unit is damaged check with the store or distributor you purchased this alternator from. They will have to file a claim with the carrier if damaged during transportation or they will check with the factory if parts are missing.

## UNIT MOUNTING

The alternator and prime mover must be operated on a firm, dry, and clean location. The area must be free of heavy dust, sand or dirt, and standing water and snow.

The alternator **must** be securely mounted to a solid base for satisfactory operations. Use heavy duty nuts and bolts. Lockwashers should be utilized to insure mounting bolts don't work loose. Refer to figure 1 for mounting dimensions. If the alternator is not securely mounted, it could

easily flip over, during maximum alternator load conditions, causing injury to the operator and damage to the alternator. On lawn and garden tractor models consult the separate instruction sheet included which gives detailed information on the alternator and tractor mounting method.

### WARNING

**Do not operate unit unless securely mounted to a solid base to avoid injury to the operator and/or damage to the alternator.**

## OPERATING SPEED

### CAUTION

**Excessive alternator speed (over 3600 RPM) can cause damage to the alternator's internal components and result in high output voltages which could damage items being powered by the alternator such as TV sets, light bulbs, etc.**

The alternator can be rotated in either direction but **must** be operated at a **constant speed** of 3600 RPM (3000 RPM for 50 Hertz export models) to provide rated voltage. Excessive speed (over 3600 RPM) will produce higher than rated voltage, low speed will produce lower than rated voltage. Even with no load on the alternator, excessive speed will cause damage to internal components of the

NOTE A 1250 THRU 4500 WATT  
HAVE 3/4 IN. DIAMETER  
SHAFT. 6000 WATT  
MODEL HAS 1-1/4 IN.  
DIAMETER SHAFT.

\* I.H. GARDEN TRACTOR MODEL ONLY  
† 6000 WATT MODELS

LENGTH	WATTAGE
13.13	6000
12.83	4500
10.94	3000
9.50	1250 & 2000

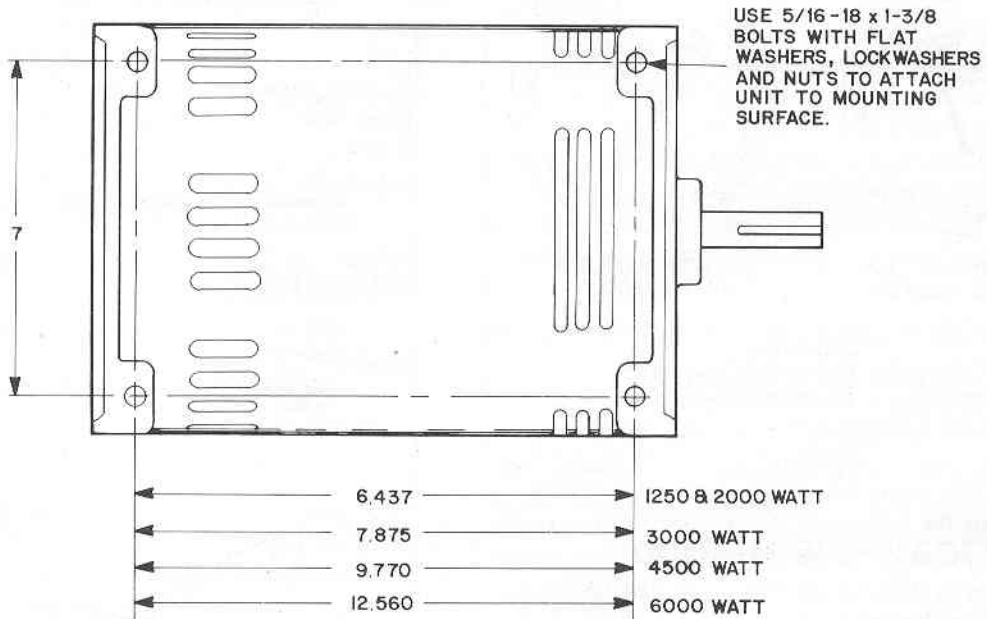
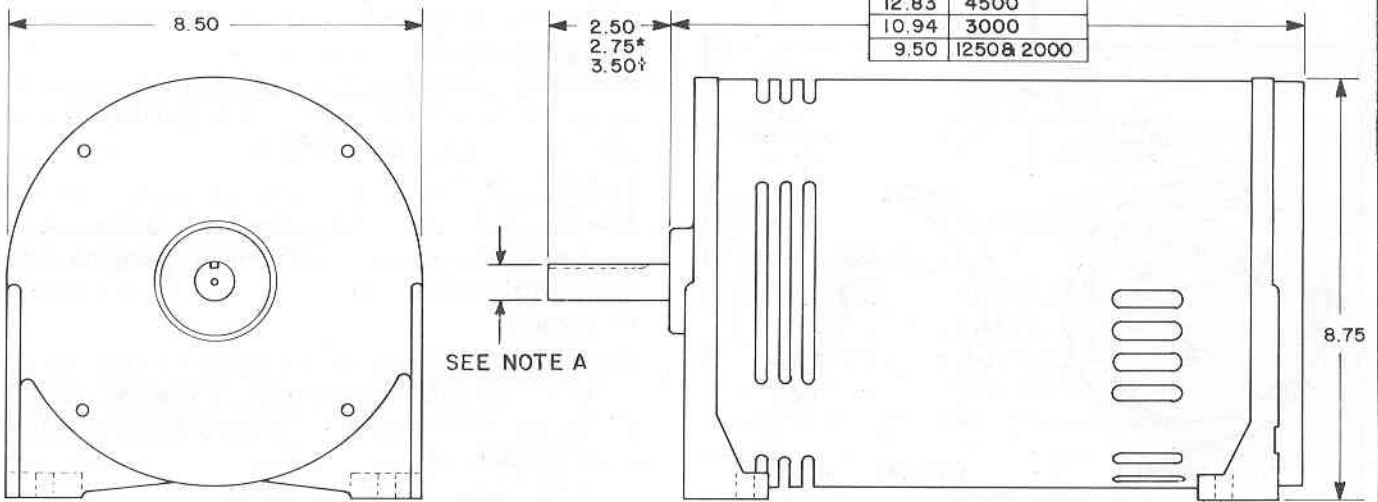

NOTE: DIMENSIONS ARE IN INCHES.

A332

FIGURE 1

alternator exciter system. With a load on the alternator, overspeeding will cause excessive output voltage which could damage items being powered by the alternator such as TV sets, light bulbs, etc.

Use the unit mounted voltmeter to determine proper alternator speed. The voltmeter needle should be in the top of the green arc (fig. 2) for normal operation.

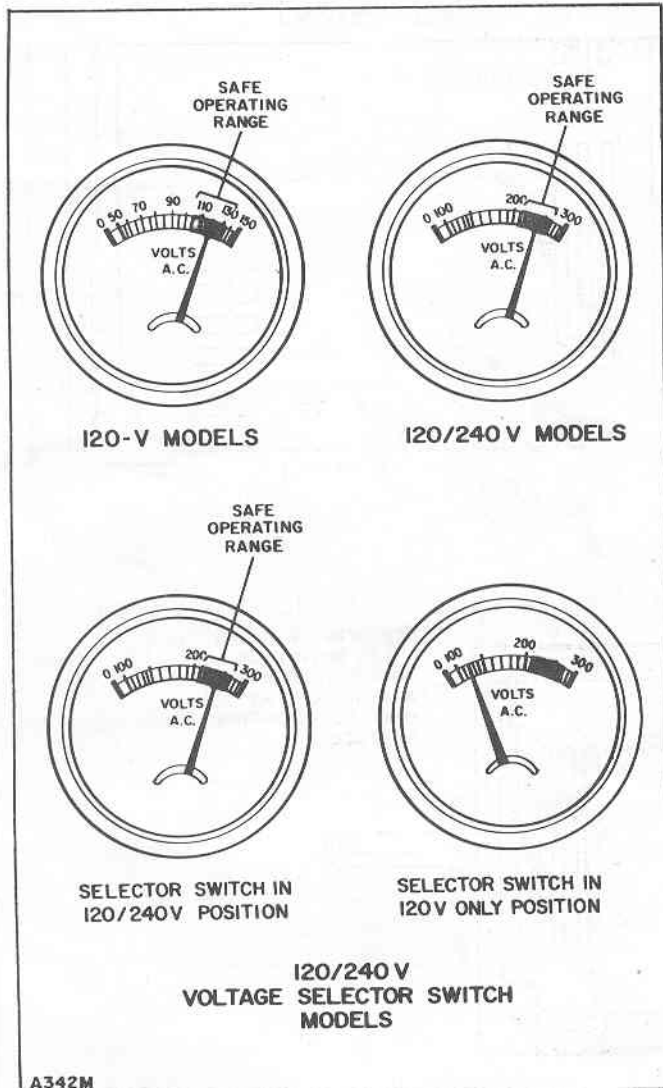

FIGURE 2

### ALTERNATOR DRIVE METHOD

The alternator stub drive shaft is equipped with a key way. The customer must supply a steel key and a method of driving the alternator, such as a pulley and V-belt or a flexible or solid drive coupling. The manufacturer does not supply V-belts, keys or pulleys with this unit (except lawn and garden tractor models which include a complete mounting hitch, V-belt, and pulley). The 1250 thru 4500 watt models require a 3/16" x 3/16" x 1-3/4" steel key. The 6000 watt models require a 1/4" x 1/4" x 1-1/4" steel key.

This unit can be operated by any prime mover that will deliver the rated horsepower needed for proper alternator operation as specified in charts 1 and 2. The alternator must operate at a constant 3600 RPM (3000 RPM for 50 Hertz models). Gasoline or diesel engines, electric motors, tractors or any other prime mover will prove satisfactory. The factory recommends a single V-belt pulley drive (fig. 3) on units up to 3000 watts and a dual V-belt drive on the 4500 watt and 6000 watt models. **Do not use a pulley with a diameter of less than 5 inches.**

**CAUTION**

If the alternator is being powered by a lawn and garden tractor only, use the approved hitch supplied with the unit. Using an unapproved hitch could possibly damage the alternator and/or the tractor.

If using a V-belt drive, the belt should be loose enough to feel springy but tight enough to prevent slipping. If belt is too tight, premature bearing problems could occur (fig. 3).

**WARNING**

All drive shafts, pulleys, and belts should be equipped with guards. Do not operate with guards removed. Avoid getting clothing or hands caught in moving parts.

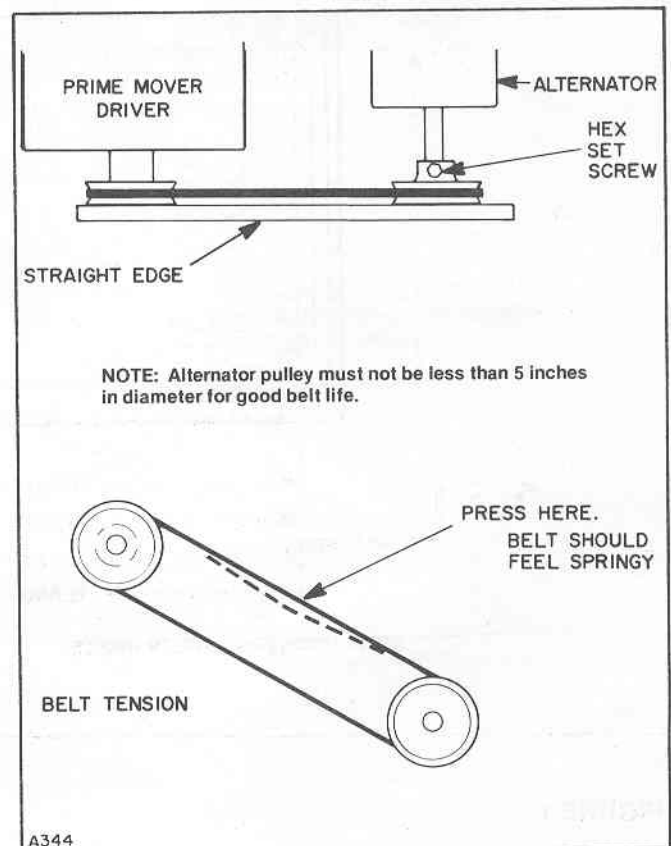

FIGURE 3

## PROPER VENTILATION

### WARNING

Provide adequate ventilation for safe, efficient operation. Invisible carbon monoxide fumes given off by gasoline or diesel prime movers are poisonous if inhaled.

If using a lawn and garden tractor, gasoline, or diesel engine as a prime mover for this unit, provide adequate ventilation. They all give off carbon monoxide gas which is poisonous if inhaled.

## MINIMUM PRIME MOVER SIZE

The minimum suggested horsepower (HP) to be utilized for alternator prime movers listed in the charts below should be used to insure proper operation and nameplate rated wattages.

Refer to the following charts.

CHART 1

Recommended Electric Motor Drive HP At Alternator Drive Shaft					
1250 W	1800 W	2000 W	3000 W	4500 W	6000 W
2.1 HP	3.6 HP	4.0 HP	6.0 HP	8.0 HP	12.0 HP

CHART 2

Recommended Minimum Gasoline Engine BHP at the Alternator Drive Shaft					
1250 W	1800 W	2000 W	3000 W	4500 W	6000 W
3.0 HP	4.0 HP	5.0 HP	7.0 HP	10.0 HP	13.0 HP

NOTE: Most popular production single cylinder four cycle engines will only produce about 85 to 90% of their maximum nameplate BHP.

Using prime movers with less horse power than listed in the above charts will result in less than nameplate stated wattages but if proper operating speed of 3600 RPM is maintained the unit will still produce the nameplate stated voltage.

Be sure to consider belt, pulley, and coupling drive HP losses when sizing the prime mover for this alternator. The HP's shown on the charts are the minimum to be utilized to insure that the units will produce their rated wattages. For lawn and garden tractor applications, the HP at the tractor power take off must correspond to the HP values in Chart 2.

## UNIT GROUNDING

### WARNING

This unit must be properly grounded to prevent a lethal electrical shock hazard. Only grounded three prong plugs must be utilized with the receptacles on this unit. Use only three wire extension cords. Use three wire power tools or double insulated power tools.

There is a ground lug or terminal located near the outlet receptacles (fig. 4). A #10 copper stranded ground wire

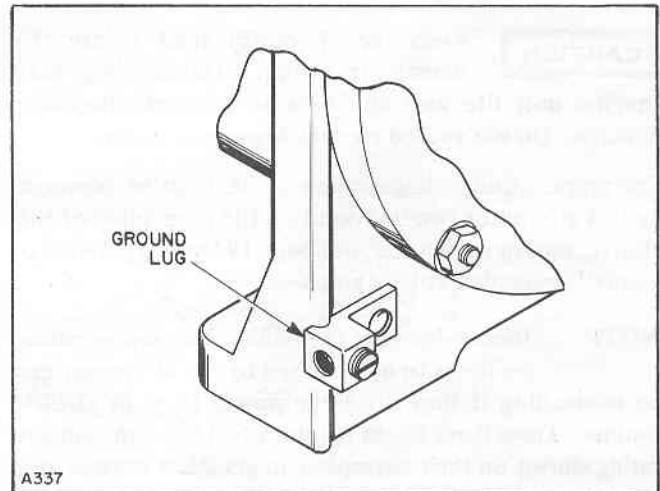

FIGURE 4

must be connected to this ground lug and a suitable ground such as a metal stake or ground rod driven into the ground. The National Electric Code and all state and local codes must be complied with. Consult your utility, power company or a licensed electrician.

## BREAK-IN PROCEDURE

This alternator requires no break-in period.

## HIGH AND LOW TEMPERATURE OPERATION

The alternator will not normally be affected by extreme ambient temperatures. Extreme low ambients found in arctic regions could cause the lubricant in the sealed life-time ball bearings to freeze and prevent the rotor from turning unless the unit is prewarmed before operation. Extreme high ambients (above 110°F) could cause a slight derating in the output amperage of the alternator.

## DUST, DIRT, RAIN, AND SNOW

Excessive dust and dirt around the unit during operation will be sucked thru the alternator and prolonged operation in such conditions could cause erratic operation and/or alternator damage. Rain and snow will not affect the alternator during normal operation but the unit should be protected as much as possible from the elements during operation.

### WARNING

Use extreme care to avoid a lethal shock hazard if this unit is operating outdoors during periods of visible moisture (rain or snow) or near standing water. Unit must be effectively grounded and all plugs should be of the three prong grounded type.

## APPLYING THE LOAD

**CAUTION** Keep the alternator load within the nameplate rating. Overloading may shorten unit life and could cause internal alternator damage. Do not exceed receptacle ampere ratings.

The ampere and voltage rating of items to be powered by this alternator can be found on the nameplate of the electric tool or appliance. See page 19 “wattage requirements” remember  $\text{volts} \times \text{amps} = \text{watts}$ .

**NOTE** Remember that the nameplate ampere rating on items to be powered by the alternator can be misleading if they are large power tools or electric motors. These items might require 2 to 3 times the ampere rating shown on their nameplate to get them started. See page 19 for detailed information for figuring the load wattage requirements.

The total output ampere rating stamped on the alternator nameplate always refers to the highest voltage the unit is equipped to produce. On 120/240 volt units this would be 240 volts. To determine the total 120-volt ampere rating double the 240-volt amperage provided on the nameplate.

Connect the load by inserting the plugs into the proper output receptacles. The load should be applied gradually. If the load consists of large electric motors they should be **individually** started, the largest first; then other low demand items can be added to the load. The voltmeter should read 130 to 140 volts no load on single voltage models (fig. 5) or 250 to 260 volts no load on 120/240-volt dual voltage models. On voltage selector switch models the voltage reading will depend on switch position, see fig. 2. As the unit reaches full load the voltage will drop to 110 to 120 volts or 220 to 230 volts depending on the alternator model. If the voltage drops below 110 or 215 volts (depending on the model), as the load is being

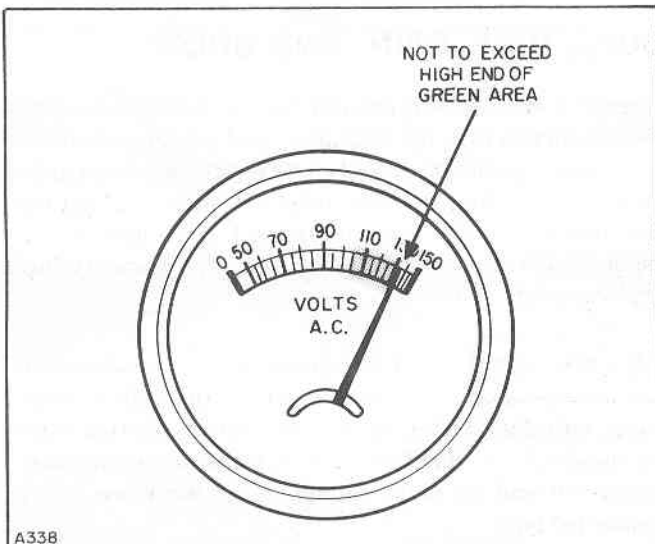

FIGURE 5

applied, no further load should be added. This indicates that either the alternator is being overloaded or the prime mover powering the alternator is overloaded or is undersized and not producing the horsepower required. On garden tractor models the tractor throttle might have to be advanced as the load is added to keep the voltmeter needle in the center of the green voltmeter scale. If the throttle is advanced and the voltmeter needle does not increase, or drops if more load is added, no further load should be added as the alternator or tractor engine is at full load. It then might be necessary to remove some of the load to keep the voltmeter in the green arc and unload the prime mover.

**CAUTION** Do not increase the alternator speed to get more output from the alternator. Overspeeding will result in higher alternator output voltage and could cause damage to load items or alternator internal exciter system.

## PROPER RECEPTACLE UTILIZATION

The individual load items to be powered by this alternator should be taken from the various outlet receptacles located in the alternator end bell. All models are equipped with three-prong grounded receptacles to comply with the National Electrical Code requirements to avoid a lethal shock hazard. All plugs on items to be powered from the alternator receptacles should be of the three-prong grounded type. Only three-wire extension cords, and three-wire or double insulated power tools should be used with this alternator. The operator must not overload either the alternator or alternator receptacles.

**CAUTION** Do not exceed the amperage rating of the outlet receptacles. This will cause receptacle burnouts and could cause internal damage to the alternator.

Three basic output receptacle configurations offered; 120 volt single voltage models, 120/240 volt dual voltage models, and 120/240 volt dual voltage models with voltage selector switch. Each type will be discussed in detail in this section.

Proper utilization of the outlet receptacles found on this alternator is necessary to avoid alternator and receptacle damage and to insure satisfactory alternator operation. The operator must realize that this alternator is **not** an unlimited source of power and heed alternator and receptacle voltage and ampere ratings (fig. 6). The nameplate ratings can be obtained thru a combination of the receptacles or a single receptacle if the alternator and/or the receptacle ampere rating is not exceeded. 120 and 240 volt receptacles can be utilized at the same time on dual voltage models. On voltage selector switch models the switch must be in the “120/240” position to utilize both the 120 V and 240 V receptacles.

## INDIVIDUAL RECEPTACLES

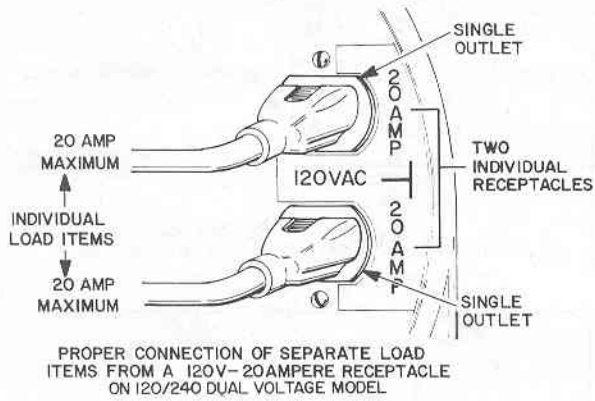

PROPER CONNECTION

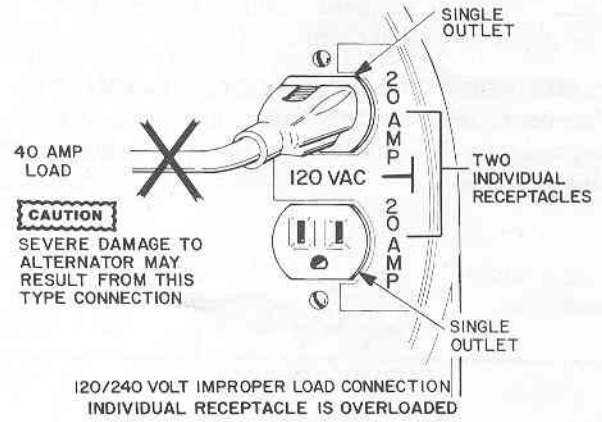

IMPROPER CONNECTION

A403

## DUPLEX RECEPTACLE

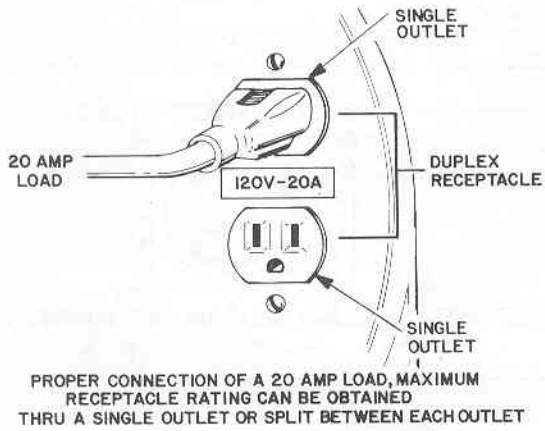

PROPER CONNECTION

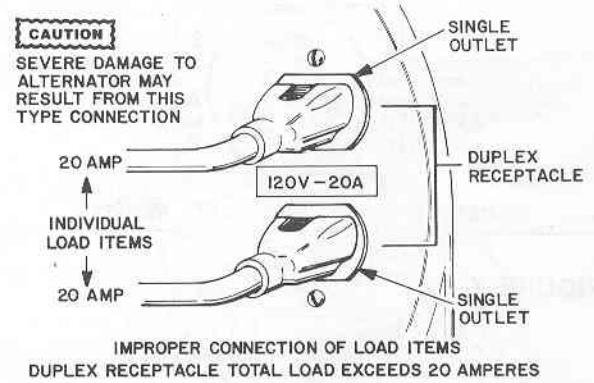

IMPROPER CONNECTION

A480

FIGURE 6





**ONE YEAR  
DUAL BEARING ALTERNATOR  
LIMITED MANUFACTURER'S WARRANTY**

PINCOR warrants for a period of one year that each alternator, generator, or electric product of its manufacture is free from defects in material and workmanship if properly installed, serviced and operated within nameplate rating under normal conditions according to PINCOR's written instructions.

PINCOR's obligation under this warranty is limited to correcting without further charge at its factory or an authorized PINCOR Service Station, any part or parts which shall be returned transportation charges prepaid, and which upon examination shall disclose to the factory's satisfaction to have been originally defective. Repair or replacement at PINCOR's option shall include charges for labor in accordance with rates approved by PINCOR. PINCOR shall not be liable for transportation charges and incidental or consequential damages.

This warranty does not apply to any items which must be repaired or replaced because of normal wear, which have been subject to misuse, negligence, accident, or which have been repaired or altered by others outside of the Manufacturer's factory unless they are authorized by PINCOR.

PINCOR shall not be liable for loss, damage, or expense directly or indirectly from the use of the product nor for the fitness of the product for any specific application or particular purpose.

All claims shall be brought to PINCOR's attention within thirty days after discovery that the product failed to perform as warranted, but in no event shall a claim be accepted after one year from the date of delivery of the product to the original user.

No person, agent, distributor, dealer, or authorized service station is authorized to give any other warranties on behalf of PINCOR or assume for PINCOR any other liability in connection with any of its products unless made in writing and signed by an officer of PINCOR.

*Electric Generating Systems Since 1932*

Pioneer Gen-E Motor Corporation, 5841 West Dickens Avenue  
Chicago, Illinois 60639, phone 312-237-4100 U.S.A.



PART NO. 21800-000-7-76

— PLEASE FILL OUT AND MAIL —

**REGISTRATION CARD**

DATE PURCHASED \_\_\_\_\_ SERIAL NO. \_\_\_\_\_ OFF NAMEPLATE \_\_\_\_\_  
MODEL \_\_\_\_\_ SPEC. NO. (SS) \_\_\_\_\_ OFF NAMEPLATE \_\_\_\_\_  
OWNER'S NAME \_\_\_\_\_  
ADDRESS \_\_\_\_\_  
CITY \_\_\_\_\_ STATE \_\_\_\_\_ ZIP \_\_\_\_\_  
THIS UNIT WILL BE USED FOR: PURCHASED FROM:  
 HOME/FARM STANDBY POWER FIRM \_\_\_\_\_  
 CONSTRUCTION/INDUSTRIAL ADDRESS \_\_\_\_\_  
USE \_\_\_\_\_  
 USE WITH GARDEN TRACTOR CITY \_\_\_\_\_  
 STATE \_\_\_\_\_ ZIP \_\_\_\_\_

NOTE: THIS REGISTRATION CARD TO BE REMOVED BY PURCHASER

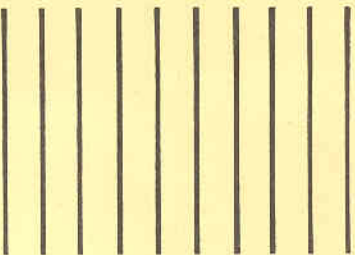

**PINCOR PRODUCTS**  
5841 W. DICKENS AVE.  
CHICAGO, ILLINOIS 60639

PLACE  
STAMP  
HERE

— WARNING —

- **READ THE UNIT OPERATOR'S MANUAL** — Failure to do so could cause non-warranty damage to this unit or injury to the operator. This unit should be operated only by a responsible adult.
- **PROTECT AGAINST MOVING PARTS** — This unit must be securely mounted. Avoid moving parts and wearing loose clothing around moving parts. All belts, pulleys and power drives should be covered. Keep all power shields and guards in place.
- **LAWN AND GARDEN TRACTOR MODELS** — If this unit is to be used with a lawn & garden tractor, only use the mounting hitch supplied with this unit. Otherwise you could void your tractor warranty by using a non-approved alternator attaching method.
- **GUARD AGAINST ELECTRIC SHOCK** — The output of this unit could cause injury to the operator. Use extreme caution when working with this unit. This unit must be effectively grounded and all electric tools or appliances to be powered by this unit should have grounded plugs. Follow all state and local codes and the National Electric Code.
- **TRANSFER SWITCH** — If this unit is used as a standby source of power if the main utility power fails, an approved multi-pole double throw manual transfer switch must be installed to isolate the main utility power source from the energy alternator source. (Consult your local utility.)
- **UNIT REPAIR** — Major repairs on this unit should only be attempted by a qualified repair station. Failure to do so could result in non-warranty damage and injury to the operator.