

RV GENERATOR TROUBLESHOOTING GUIDE

A Service of



FLIGHT SYSTEMS

207 Hempt Road · Mechanicsburg, PA 17050

Ph: 717 590 7330 Fax: 717 590 7327 www.flightsystems.com

CONTENTS

RV Generator Troubleshooting Overview	1
RV Generator FAQs	5
<u>Onan® RV Generator Charts:</u>	
Applications Chart	8
Test Information for Troubleshooting	
9	
Regulator Pin Assignment Chart	10
Control Board P/N Supersedence	10
Oil Press/Level Switch Locations	10
<u>Onan® RV Generator Control Board & Regulator Illustrations</u>	
Voltage Regulator Mating Plug	11
300-2784/2943 Control Board (Onan® Original)	11
300-2784/2943 Control Board (F.S. Replacement)	
12	
300-3056/3687 Control Board	12
300-3763/3764 Control Board	13
300-4901 Control Board	13
300-4902 Control Board	14
300-4320 Control Board	14
300-4155 Control Board	15

RV GENERATOR TROUBLESHOOTING OVERVIEW

HOW DOES MY RV GENERATOR WORK?

***Note:** While this troubleshooting guide is applicable to most makes of RV Gen Sets, there are many specific references to particular Onan® Models as these widely used RV Generators are the brand we (Flight Systems) provide replacement control boards, voltage regulators and test equipment (the G-MAN) for.*

What the Engine Control Board Does

The engine control board or module controls the ignition, fuel pump, fuel solenoid (if equipped), field flash and starter. On LP models, it controls the flow of LP gas to the throttle body. Some models prevent the engine from starting if there is insufficient oil quantity. Some models prevent continued running if there is insufficient oil pressure. See Troubleshooting Chart. NOTE: On models equipped with electronic governors (BGM, NHM Spec. B and later, 300-3764 control board), the oil pressure signal to the control board comes from the governor module. Additionally, most models require a voltage from the generator to keep the engine running once it has started. See Troubleshooting Chart. All controls terminate cranking and lock out the starter after the engine has started. The battery charging circuit is part of the control board on some models, and external on others. **NOTE: The controls used on Models KY (Spec. J), KYD (Spec. A), HGJAB and HGJAC are microprocessor-based and combine the functions of the engine control and regulator in one module (300-5046, 327-1413 and 300-5374). Because these modules are difficult or impossible to access without special tools, they are not covered in these instructions.**

What the Regulator Does

When the generator is first started, the regulator receives the field flash voltage from the control board and applies it to the generator field (rotor) to initiate AC voltage buildup in the stator. After the generator output voltage builds up, the regulator maintains it nearly constant (within a few volts of 120 VAC) under conditions of varying load. It does this by sensing the 120 volts and constantly adjusting the DC field (rotor) voltage up or down, as needed. For example, if you turn on a light, the regulator would respond by increasing the field voltage only slightly to compensate for the added load. If you turn on a microwave oven or an air conditioner, the regulator would increase the field voltage by a much larger amount, in proportion to the heavier load. The regulator has a built-in protection circuit that reduces the output voltage of the generator if the engine is running too slow. The purpose of this feature is to protect your appliances from receiving full voltage at the lowered frequency, as this can cause damage to motors and transformers.

What the Bridge Rectifier Does

The Bridge Rectifier is found on RV generators that do not have an electronic voltage regulator. This will typically be found on BGE / NHE generators spec A-E. It serves two major functions, field flash and field (rotor) voltage supply. Upon starting, the control board provides 12 volts DC to the field windings via the + terminal of the rectifier. Once oil pressure comes up another set of relays closes and opens accordingly, on the control board, and then the rectifier begins to work. It now takes sensed voltage from the regulating transformer on the AC leads and rectifies it to DC voltage on the + and – terminals. This is now the DC voltage that supplies the rotor of the generator.

Normal Starting Sequence

This is what normally happens when you start your genset. Pressing and holding the start switch causes the control board to send 12 volts to the ignition, fuel pump, choke heater, start solenoid and field flash circuits. The engine then cranks and starts. Oil pressure and generator voltage build up within 1-2 seconds. This causes the control board to keep sending 12 volts to the ignition, fuel pump and choke heater while cutting off 12 volts to the starter solenoid and field flash circuits. The start switch can then be released and the engine keeps running. Some models differ slightly in operation. On models equipped with magneto ignition (KV, Spec. C-F; KY, Spec. A-E), the control board un-grounds the magneto kill circuit. Model KY, Spec. B-E uses a fuel solenoid in addition to the fuel pump. Models fueled by LP gas use a fuel shutoff solenoid valve instead of a fuel pump. Several conditions can prevent the engine from starting/running and are covered under Troubleshooting.

Normal Stopping Sequence

This is what happens when you stop your genset. Pressing and holding the stop switch for a few seconds causes the control board to cut off the 12 volts to the ignition and fuel pump (and/or fuel solenoid valve) causing the engine to stop. On models equipped with magneto ignition, the control board grounds the magneto kill circuit. Several conditions can cause the engine to stop by itself and are covered under Troubleshooting.

TROUBLESHOOTING

Determine the control board part number from the board or from the Application Chart, then refer to the Troubleshooting Chart for test information specific to that board. This troubleshooting guide assumes that the person doing the work has basic mechanical skills and is familiar with electrical troubleshooting procedures using a multi-meter. Having a practical knowledge of RV generators is helpful, but not absolutely necessary. **DISCLAIMER: Generator servicing can present certain hazards such as cuts, burns, electric shock, fire, and exposure to exhaust fumes. Take suitable precautions. Flight Systems will not assume any liability for personal injury or damage to equipment or property as a result of using this Troubleshooting Guide.**

Getting the Engine Running

Before any evaluation of the controls, regulator or generator can proceed, the Onan engine must have oil and fuel, be in running condition and the 12-volt battery charged. The electronic governor, 151-0752, on Models BGM and NHM, Spec B and later, must be functioning properly. This guide does not cover engine maintenance and repair procedures (please refer to the applicable Onan Service Manual for this information). The most common engine problems are caused mainly by lack of use and/or lack of regular monthly exercise and include the following:

- Low battery voltage because of insufficient charge, worn out battery, faulty cables (partly broken or corroded) or poor connections, resulting in slow cranking and hard starting.
- Old or contaminated fuel that has gummed up the lines, fuel filter and carburetor. This can cause clogged jets (mixture too lean) and/or a stuck carburetor float resulting in an improper mixture (too rich or too lean) or flooding.
- Weak spark and/or fouled spark plug(s) causing hard starting and rough running.
- Stuck automatic choke causing an excessively rich mixture and smoking.
- Stuck oil pressure switch causing shutdown as soon as the start button is released.
- Dirty air filter, causing an excessively rich mixture and smoking.
- Low oil level preventing starting on models equipped with low oil level switch.
- Wiring harness damage from rodents chewing on the wires.
- Corrosion of control board or connections from salty air or road chemicals.

FOLLOW THESE STEPS:

1. **CHECK OIL** Check engine oil level *before* starting.
2. **GAIN ACCESS** Remove panel or cover to gain access to the control board. Some disassembly may be required. The exact procedure depends on the model.
3. **CHECK BATTERY VOLTAGE** Connect the negative voltmeter lead to GROUND and the positive lead to the positive battery cable on the starter solenoid and read the battery voltage. The same reading should be obtained at the BATTERY POSITIVE pin of the control board. A fully charged battery in good condition should read 12.6 to 12.8 VDC. Charge the battery if necessary.

CHECK CRANKING Try to start the engine. If it does not crank, check the control fuse (5A Slo Blo, except models with electronic governor 10A). If the fuse is good, jumper the positive battery post to the coil terminal on the start solenoid. If the engine cranks, there is a poor connection, wiring damage or the control board is defective. If the engine cranks when the BATTERY POSITIVE pin is jumpered to the START SOLENOID pin on the control board, the board is defective. NOTE: The battery voltage should not go below 9.5 VDC during cranking.

2. **CHECK SPARK** If the engine cranks but does not start, remove a spark plug and check for spark during cranking (spark plug must be grounded). Temporarily jumper the ignition coil positive to the starter solenoid positive terminal, or jumper the BATTERY POSITIVE pin to the IGNITION pin on the control board. If you now have spark, there is a poor connection, wiring damage or the control board is defective. To determine if it is the control board, check for 12 volts at the IGNITION pin during cranking. Other problems such as dirty /worn points or a defective coil can cause loss of spark. On models where the oil level switch is hard-wired to the magneto (KV Spec. C-F, KVC and KVD), low oil level or a stuck switch will inhibit the spark and prevent starting. On these models, it may be necessary to temporarily disconnect the oil level switch if it is stuck closed and not opening. To check the level switch, unplug the control board and verify that the MAGNETO KILL circuit on the control harness is not grounded. Refer to the Troubleshooting Chart.
3. **CHECK FUEL SYSTEM** If the engine cranks and has spark but does not start, the problem is likely fuel related. This can be confirmed by injecting a *small* amount of starting fluid into the air intake. If the engine fires and tries to run, it is starving for fuel. Listen for the fuel pump running during cranking. Check for 12 volts at the FUEL PUMP pin on the control board during cranking. If there is no voltage, the control board is defective. The pressure and flow of the fuel pump (and fuel filter) can be checked by temporarily disconnecting the fuel line to the carburetor and jumpering the FUEL PUMP pin on the control plug to battery positive. Take adequate precautions when handling fuel. If pressure and flow are normal, reconnect fuel line. Note: If the generator has not been run for several months, the carburetor float may be stuck closed and /or the jets and needle valves may be gummed up by old fuel that has turned to varnish. These conditions interfere with normal fuel delivery. The automatic choke may be stuck closed or binding so that it does not open as the choke heater warms up. On Models BGM and NHM spec. B and later, make sure that the electronic governor goes to full throttle one second after cranking begins. Any of these conditions will prevent the engine from starting or running smoothly and must be corrected before proceeding.
4. **CHECK IF ENGINE KEEPS RUNNING** The most common complaint is that the engine starts but will not keep running when the START switch is released. This happens because the control board will not allow the engine to continue running if the generator is not producing voltage *or* if the oil pressure signal is not present. See CONDITIONS REQUIRED TO KEEP RUNNING on the Troubleshooting Chart for your model. If the engine will not keep running, do the following:
 - A1. **Generator AC Output** Check the generator AC output voltage as soon as the engine starts. Models showing “B1-B2 Volts” or “L1 AC Volts” under CONDITIONS REQUIRED TO KEEP RUNNING need this AC voltage to keep running. Read between the points shown on the Troubleshooting Chart. If the AC voltage readings are good, proceed to “B” below.
 - A2. **Field Flash** If there is no AC, check for 10-12 VDC at the FIELD FLASH pin of the control board during cranking. If the field flash voltage is not present, the control board is defective. If the field flash voltage is present, the wiring or regulator may be defective. To eliminate the wiring, check continuity between the FIELD FLASH pin of the control board and pin 7 of the regulator. If the continuity is good, either the regulator or the field circuit (rotor and brushes) may be the problem.
 - A3 **Field Circuit** Check the field circuit by unplugging the regulator and measuring the resistance between pins 9 and 10 of the regulator’s mating plug. This reading should be 22 to 28 ohms. If this reading is too high, check the brushes and/or clean the slip rings (use the Slick Stick, or a similar tool). If this reading is too low, there may be a short in the rotor. Also, check the resistance from pins 9 and 10 to ground. This reading should be very high or infinity. If not, there is likely a ground in the rotor. If these reading are all

A4 External Excitation To confirm that the regulator is defective, turn off the generator's AC circuit breaker(s), reconnect the regulator and apply 12 volts through a diode to pin 9 of the regulator plug (see illustration) while attempting to start the engine. CAUTION: DO NOT attempt this without the diode. If you do, there will be fireworks! Remove the 12 volts within 1-2 seconds after the engine starts. If the genset now continues to run and produces normal AC voltage, the generator is OK and the regulator is defective. If the genset does not continue to run but produces about 40% of normal AC voltage, again the generator is OK and the regulator is defective. If no AC voltage is produced, the generator may have a problem that is beyond the scope of this guide. Re-check all wiring for security and signs of damage. It may be necessary to take the unit to a qualified repair shop.

B. Check the oil pressure switch as soon as the engine starts. Models showing "LOP to GND" under CONDITIONS REQUIRED TO KEEP RUNNING need the oil pressure switch to be closed to ground when running. If the voltage on the LOL/LOP SW pin of the control does not go to near zero, the switch is not closing. These switches sometimes stick open if the generator has not been used or exercised often enough. Multiple start/stop cycles and/or tapping on the oil pressure switch will sometimes fix it. It may be necessary to temporarily jumper the switch to ground to keep the engine running. This can be done at the switch or at the OIL LOL/LOP SW pin on the control board. Models showing "LOP Open" under CONDITIONS REQUIRED TO KEEP RUNNING have electronic governors and require the low oil pressure switch to be *closed* at starting but *open* during running. When the switch opens, the governor module places a ground on the oil pressure input of the control board (P1-5). It is OK to temporarily ground P1-5 on this model to keep the engine running. NOTE: See chart for oil pressure and oil level switch locations.

C. If there is AC voltage present on B1-B2 or L1 AC, as applicable, and the correct oil pressure/level signal is present at the OIL LOL/LOP SW input of the control board, and the engine will not keep running, the control board is defective.

1. After the engine has been running for a few minutes, the electric choke heater should begin to open the choke. The choke will take longer to open fully in cold weather. If the choke does not open, it is either stuck or the choke heater is not working. The choke mechanism can be freed up and maintained with "Mouse Milk", a high temperature penetrating lubricant.
2. If the engine surges or "hunts" (does not stay at a constant RPM), the cause is likely a gummed-up carburetor or an improperly adjusted governor. These conditions should be corrected. If your multi-meter has a "frequency" or a "Hz" range, you can check the RPM by measuring the frequency of the 120 VAC at the outlet. It should be approximately 62 Hz at no load and not go below 58 Hz at full load.

RV GENERATOR FAQs

The following FAQ's apply primarily to Onan generators installed on many RV's, but due to their general nature, may apply equally well to other makes. The information below is intended to help you get the best satisfaction from your RV genset and to enable you to find and correct some of the more common problems. Certain models are not covered because of their complexity and the need for specialized servicing tools. These include: Quiet Diesel Models HDKAJ, HDKAK and HDKAT; Microlite Model KY Spec. J and later; Camp Power Model KYD; Mobile Genset Models HG-JAB and HGJAC. Refer complex servicing to a qualified generator service facility.

Q. When the start switch is pressed in the coach or at the generator, nothing happens. What could be the problem?

A. The coach battery could be completely discharged or there could be a problem with a battery cable, the control board or the wiring. If the coach interior lights will not work, the problem is likely the coach battery. Check the battery and control fuse first. If the lights work, use the Troubleshooting Guide to isolate the problem.

Q. When the generator start switch is pressed, the starter makes a clicking sound but the engine does not crank. What is the problem?

A. Most likely, the coach battery is almost completely discharged and needs to be charged or replaced. There could also be a poor connection or a defective battery cable or starter solenoid. If these causes can be eliminated, then the starter itself may need service.

Q. Why does my generator crank over normally but not start?

A. The problem is either fuel or ignition related. If the engine tries to run when a small amount of starting fluid is sprayed into the air intake, it is a fuel problem. The ignition can be checked by removing and grounding a spark plug. Refer to the "Getting the Engine Running" section of the Troubleshooting Guide to isolate the problem.

Q. Why does my generator start and then shut down as soon as the start switch is released?

A. Most models require *both* oil pressure and AC voltage from the generator to keep running. A lack of AC voltage can be caused by a variety of problems involving the control board, regulator, generator and wiring. A stuck oil pressure switch can also cause this symptom. The interaction between the various components of the system can be confusing during troubleshooting. Use the Troubleshooting Guide to isolate the problem.

Q. The start switch works at the generator but not from inside of the coach. What is the problem?

A. The remote start/stop control is not connected to the control board. Make sure the remote connector is plugged in to the control at the generator. Check remote switch and wiring.

Q. The start switch works from inside of the coach but not at the generator. What is the problem?

A. The start switch on the control board or control panel is defective. Replace the switch or control board, as applicable.

Q. Why does my generator run rough and/or smoke, even after it is warmed up?

A. This can be caused by the electric automatic choke not opening (choke stuck or choke heater not working), an improperly adjusted carburetor (too rich), or a sticking carburetor float that allows excess fuel to enter the carburetor bowl. Rough running can also be caused by fouled spark plugs.

Q. Why does the generator RPM surge up and down and not stay at a constant speed?

A. Surging is caused by a gummed-up or improperly adjusted carburetor or an improperly adjusted governor.

Q. My generator starts OK, runs for a while and then shuts down. Sometimes, it can be re-started after cooling for a few minutes. What causes this?

A. The most likely cause is fuel starvation. This can be caused by low fuel level (not getting gas), vapor lock (too hot, gas is boiling), fuel contamination (water or dirt in fuel and/or filter) or a faulty fuel pump (insufficient fuel pressure). Models equipped with low oil level (LOL) switches will shut down the engine on low oil level.

Q. What can I do to prevent fuel from deteriorating and causing problems during periods of non use?

A. Regular exercise is a big help, but a fuel stabilizer such as “STA-BIL” should be added to the fuel at the start of the storage period. Follow the manufacturer’s recommendations and remember to run the generator long enough to get the treated fuel into the system.

Q. My generator was running great at the end of last season but now it has problems. What could be the cause or causes?

A. The generator was likely not exercised often enough or at all during the last period of non-use. A stabilizing additive may not have been added to the fuel (see Q & A above). There could be latent corrosion damage from road chemicals or wiring damage from rodents. The problem could be simply a stuck oil pressure switch. The problems experienced could be for a variety of causes. Generators need regular use or exercise in order to remain trouble-free. See next Q&A below and also “Troubleshooting”.

Q. How often should an RV generator be exercised and what is the procedure?

A. All RV generators should be exercised at least once per month during periods of non-use. Make sure external AC power is disconnected from the coach and the coach battery is charged. Start the generator and wait a couple of minutes for warm-up, longer in very cold weather. Load the generator by plugging in a ceramic-type portable electric heater (approx. 1KW). When the outside temperature is above 65F, use the roof air conditioner to load the generator. Allow the generator to run under load for 20-25 minutes. Remove the load and run for another 2-3 minutes as a cool down period, then shut down.

Q. The voltage at the AC outlet is too high (above 125 VAC at no load) on start up, or gradually climbs after the generator has been running for a while. What causes this?

A. If the voltage is somewhat high or climbs, the regulator is defective and needs to be replaced. If the voltage immediately goes to 160 VAC on start-up, the problem is either the regulator or a loose connection at pin 2 of the regulator. Check connections before replacing the regulator.

Q. The voltage at the AC outlet is too low (below 112 VAC at no load) or goes down more than a few volts when a load is added. What causes this?

A. First, make sure that the generator is running at rated speed. This can be done with a multi-meter that has a “frequency” or a “Hz” range. Make sure the slip rings are clean. Check the connections between pins 4 and 5 (or pins 1 and 5 on Microlite 2.8KW) on the regulator, as this can cause an output voltage of 55-60 VAC, even with a good regulator. When these causes have been eliminated, the regulator is likely defective.

Q. With the generator running, there is no 120 VAC at any of the outlets. What is the problem?

A. The AC circuit breaker(s) at the generator may be turned off or tripped. Check the breaker(s) first. Make sure that there is 120 VAC at the generator (L1-L2 on the terminal block or pins 2-3 on the regulator plug). If the circuit breaker is on, there is 120 VAC at the generator and there is still no voltage at the outlets, the problem could be a faulty transfer relay. This device is located in the coach and is not part of the generator. Its job is to switch the AC load from the commercial power to the generator when it is running.

Q. What are slip rings, where are they located and what is their function?

A. Slip rings are two flat metal rings located side by side on the rear of the rotor (end away from the engine) that provide a means of contact for the brushes. The brushes run against the slip rings and carry the current (field current) required for magnetizing the rotor.

Q. Why do the generator's slip rings require cleaning periodically?

A. During periods of storage and a lack of regular exercise, RV generator slip rings can become corroded, particularly in areas near salt water. Even with regular running, a layer of oxide and brush residue can build up on the rings, increasing their electrical resistance. Proper cleaning (*such as with the **Slick Stick Slip Ring Cleaning Tool**, available from **Flight Systems***) restores the running surface to like-new condition. This results in cooler running as well as extended brush and regulator life. Dirty slip rings can cause overheating and premature regulator failure.

Q. How can I determine if the slip rings need to be cleaned?

A. A quick visual inspection can be done by looking through the cooling slots at the rear of the generator with a bright light. The slip rings should appear as shiny clean metal. You can also unplug the regulator and measure the resistance between pins 9 and 10 of the plug that was connected to the regulator. If this reading is greater than 28 ohms, cleaning is needed.

Q. Is there a place where I can easily check for the proper voltages when the generator is running?

A. Yes. The 120 VAC and/or 60 Hz frequency can be checked between pins 2 and 3 of the regulator or at any outlet, and should be between 117 and 126 VAC at no load. The field voltage can be checked between pins 9 and 10 of the regulator and should be 35-40 volts at no load and rise to about 60 volts at full load.

APPLICATION CHART FOR 120V 60 Hz RV GENERATORS

SERIES	MODEL	SPEC	KW	FUEL	CONTROL		G-MAN CONTROL		REGULATOR	GOVERNOR
					BOARD	ADAPTER	BOARD	ADAPTER		
Emerald	BGE	A-E	4.0	Gas	300-2784	56-A360-2784	Transformer	Mechanical		
	BGE	F,G	4.0	Gas	300-3056	56-A360-3056	305-0782	Mechanical		
	BGE	H-M	4.0	Gas	300-3763	56-A360-3763	305-0809	Mechanical		
	BGE	N & up	4.0	Gas	300-4901	56-A360-4901	305-0809	Mechanical		
	BGEL	A-D	4.0	LP	300-2943	56-A360-2784	Transformer	Mechanical		
	BGEL	E-G	4.0	LP	300-3056	56-A360-3056	305-0809	Mechanical		
	BGEL	H-M	4.0	LP	300-3763	56-A360-3763	305-0809	Mechanical		
	BGEL	N & up	4.0	LP	300-4901	56-A360-4901	305-0809	Mechanical		
	NHE	A-C	6.5	Gas	300-2784	56-A360-2784	Transformer	Mechanical		
	NHE	D-G	6.5	Gas	300-3056	56-A360-3056	305-0782	Mechanical		
	NHEL	A-C	6.3	LP	300-2943	56-A360-2784	Transformer	Mechanical		
	NHEL	D,E & G	6.3	LP	300-3056	56-A360-3056	305-0782	Mechanical		
	BGM	A	5.5	Gas	300-3056	56-A360-3056	305-0826	Mechanical		
	BGM	A	5.5	Gas	300-3763	56-A360-3763	305-0826	Mechanical		
BGM	B-F	5.5	Gas	300-3764	56-A360-3764	305-0826	151-0752			
BGM	G	5.5	Gas	300-4902	56-A360-3764	305-0826	151-0752			
Microlite	NHM	A	6.8	Gas	300-3056	56-A360-3056	305-0782	Mechanical		
	NHM	A	6.8	Gas	300-3763	56-A360-3763	305-0826	Mechanical		
	NHM	B-F	6.8	Gas	300-3764	56-A360-3764	305-0826	151-0752		
	NHM	G	6.8	Gas	300-4902	56-A360-3764	305-0826	151-0752		
	KV	A,B	2.8/2.5	Gas/LP	None	N/A	305-0852	Mechanical		
	KV	C-F	2.8/2.5	Gas/LP	300-5299	56-A360-5299	305-0897	Mechanical		
	KY	A	4.0/3.6	Gas/LP	300-4155	56-A360-4155	305-0851	Mechanical		
	KY	B-E	4.0/3.6	Gas/LP	300-4320	56-A360-4320	305-0851	Mechanical		
	KY	F-H	4.0/3.6	Gas/LP	300-4923	56-A360-4320	305-0851	Mechanical		
	KY	J-L	4.0/3.6	Gas/LP	300-5046	56-A360-1413	300-5046	Mechanical		
Camp Power	KVC	A	2.8	Gas	300-5299	56-A360-5299	305-0897	Mechanical		
	KVD	A	2.8/2.5	Gas/LP	300-5299	56-A360-5299	305-0897	Mechanical		
	KYD	A	4.0/3.6	Gas/LP	327-1413	56-A360-1413	327-1413	Mechanical		
Mobile Genset	HGJAB	A	5.5/7.0	Gas	300-5374	56-A360-5374	300-5374	Mechanical		
	HGJAC	A	5.5/7.0	Gas	300-5374	56-A360-5374	300-5374	Mechanical		

TEST INFORMATION FOR TROUBLESHOOTING RV GENERATORS

CONTROL BOARD	300-3950									
	300-2943	300-3687	300-5268	300-5342	300-4155	300-4923	300-5337	300-5276	300-5299	
FUNCTION	300-2784	300-3056	300-3763	300-3764	300-3797	300-4320	300-4901	300-4902	300-4456	
BATTERY POSITIVE	P1-6	P1-6	P1-7	P1-7	J1-10	P1-10	P1-7, 8	P1-7	P1-4	
GROUND	P1-8, P2-1	P1-8	P1-11	P1-1	J1-4	P1-5, 7,8	P1-11	P1-1	P1-7	
IGNITION	P1-3	P3-3	P1-6	P1-12			P1-6	P1-12		
MAGNETO KILL					J1-6	P1-11			P2-4*	
GOVERNOR 12 VDC				P1-6				P1-6		
FUEL PUMP	P1-3	P3-6	P1-12	P1-4	J1-12	P1-2	P1-12	P1-4	P1-1	
FUEL SOLENOID						P1-3				
START SOLENOID	P1-2	P1-2	P1-9	P1-2	J1-8	P1-6	P1-9	P1-2	P1-3	
FIELD FLASH	P1-5	P1-5	P1-1	P1-3	J1-5	P1-9	P1-1	P1-3	P2-3	
OIL LOL/LOP SW	P1-4	P3-4	P1-5	J3-2	J1-7	P1-12	P1-5	P1-5	P2-4*	
AC HOT (L1 AC Volts)						P1-4				
LP SHUTDOWN	P2-2	P3-2	P1-10				P1-13			
B1	Bat. Chg. Res.	P1-1	P1-2		J1-9		P1-2		P2-1	
B2	P1-7	P1-7	P1-4		J1-11		P1-4		P2-2	
BAT. CHG. RES.	P1-1	P1-4	P1-3				P1-3			
B1-B2 or Bat. Chg. Volts Voltage Reading	P1-8 to P1-1 18-26 VAC	P1-1 to P1-7 14-16 VAC	P1-2 to P1-4 14-16 VAC	BAT+ to GND Note B+ rise	J1-9 to J1-11 14-16 VAC	BAT+ to GND Note B+ rise	P1-2 to P1-4 14-16 VAC	BAT+ to GND Note B+ rise	P2-1 to P2-2 14-16 VAC	
START/STOP										
LOCAL START	P3-3	On board	On board	On board	J1-1	P1-13	On board	On board	On board	
LOCAL STOP	P3-2	On board	On board	On board	J1-2	P1-1	On board	On board	On board	
LOCAL RETURN	P3-1	On board	On board	On board	J1-3	P1-7	On board	On board	On board	
REMOTE START	P2-3	P2-3	J2-3	J2-3	J2-3	J2-3	P1-14	P1-9	P1-6	
REMOTE STOP	P2-2	P2-2	J2-2	J2-2	J2-2	J2-2	P1-10	P1-8	P1-5	
REMOTE RETURN	P2-1	P2-1	J2-1	J2-1	J2-1	J2-1	P1-11	P1-1	P1-8	
BAT. CONDITION METER	P2-6	P2-5	J2-5	J2-5	J2-5	J2-5	P1-16	P1-11	P1-2	
TIME TOTALIZER	P2-6	P2-6	J2-6	J2-6	J2-6	J2-6	P1-15	P1-10	P1-2	
CONDITIONS REQUIRED TO KEEP RUNNING	LOP to GND B1-B2 Volts	LOP to GND B1-B2 Volts	LOP to GND B1-B2 Volts	LOP Open P1-5 to GND	LOL Open B1-B2 Volts	LOL Open L1 AC Volts	LOP to GND B1-B2 Volts	LOP Open P1-5 to GND	LOL Open* P2-4* un-GND	
GOVERNOR P/N	Mechanical	Mechanical	Mechanical	151-0752	Mechanical	Mechanical	Mechanical	151-0752	Mechanical	
REGULATOR P/N	Transformer	305-0809-01	305-0809-01	305-0826	305-0851	305-0851	305-0809-01	305-0826	305-0897	

* Low oil level switch (LOL) is hard-wired to Magneto Kill on this model.

REGULATOR PIN ASSIGNMENT

FSI Model Number	305	305	305-5	305-2.8	826	911
Onan Part Number(s)	305-0782-01			305-0852		
	305-0809-01	305-0851	305-0809-05	305-0897	305-0826	305-0911
FUNCTION						
AC Sense HI	2	2	2	2	2	2
AC Sense LO/Gnd	3	3	3	3	3	3
Voltage Adjust	4	4	4	1	4	4
Voltage Adjust Return	5	5	5	5	5	5
Capacitor Negative	6	n/c	6	6	n/c	n/c
Field Flash	7	7	7	7	7	7
Case Ground					8	8
Capacitor Positive	8	n/c	8	8	n/c	n/c
Field F1(+)	9	9	9	9	9	9
Field F2(-)	10	10	10	10	10	10
Quad (Aux) Stator Q1	11	11	11	11	11	11
Quad (Aux) Stator Q2	12	12	12	12	12	12

CONTROL BOARD P/N SUPERCEDEANCE

ORIGINAL P/N	SUPERCEEDS TO P/N	
300-2784	300-2943	
300-3056	300-3687	300-3950
300-3763	300-5268	
300-3764	300-5342	
300-3797	300-4155	
300-4320	300-4923	
300-4506	300-5002	300-5002-01
300-4901	300-5337	
300-4902	300-5276	
300-4902	300-5299	
300-5046	327-1413	

LOCATION OF OIL PRESSURE / LEVEL SWITCHES ON RV GENERATORS

SERIES	MODEL	SPEC	LOCATION AND ACCESS OF SWITCH
Emerald	BGE	All	Oil Level switch located at base of oil filter. Remove sheet metal panel surrounding oil filter to gain access.
	BGEL	All	
	NHE	All	
	NHEL	All	
Marquis	BGM	All	
	NHM	All	
Microlite	KV	All	Oil Level switch located inside of oil pan.
	KY	All	Oil level switch located on right side of oil pan.
Camp Power	KVC	All	Oil level switch located inside of oil pan.
	KVD	All	
	KYD	All	
Mobile Genset	HGJAB	All	Oil pressure switch located on main bearing cover above oil filter.
	HGJAC	All	

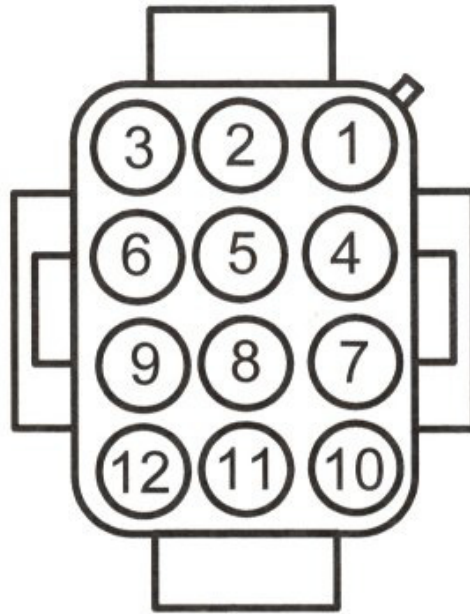

REGULATOR MATING PLUG
REAR VIEW (WIRING SIDE)

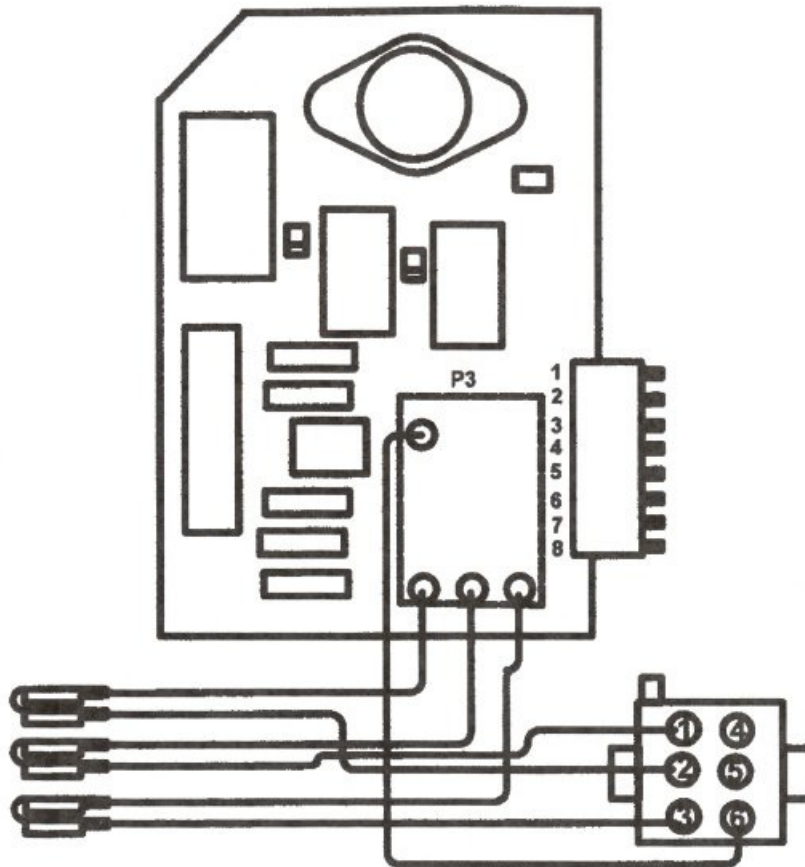

300-2784/2943 ONAN ORIGINAL

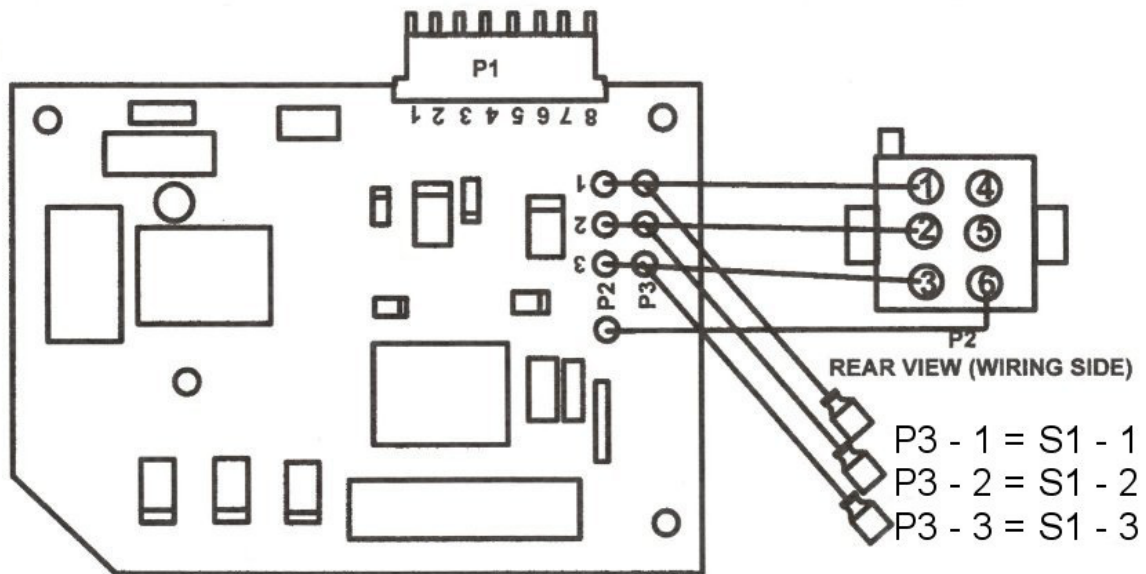

300-2784/2943 (FLIGHT SYSTEMS REPLACEMENT)

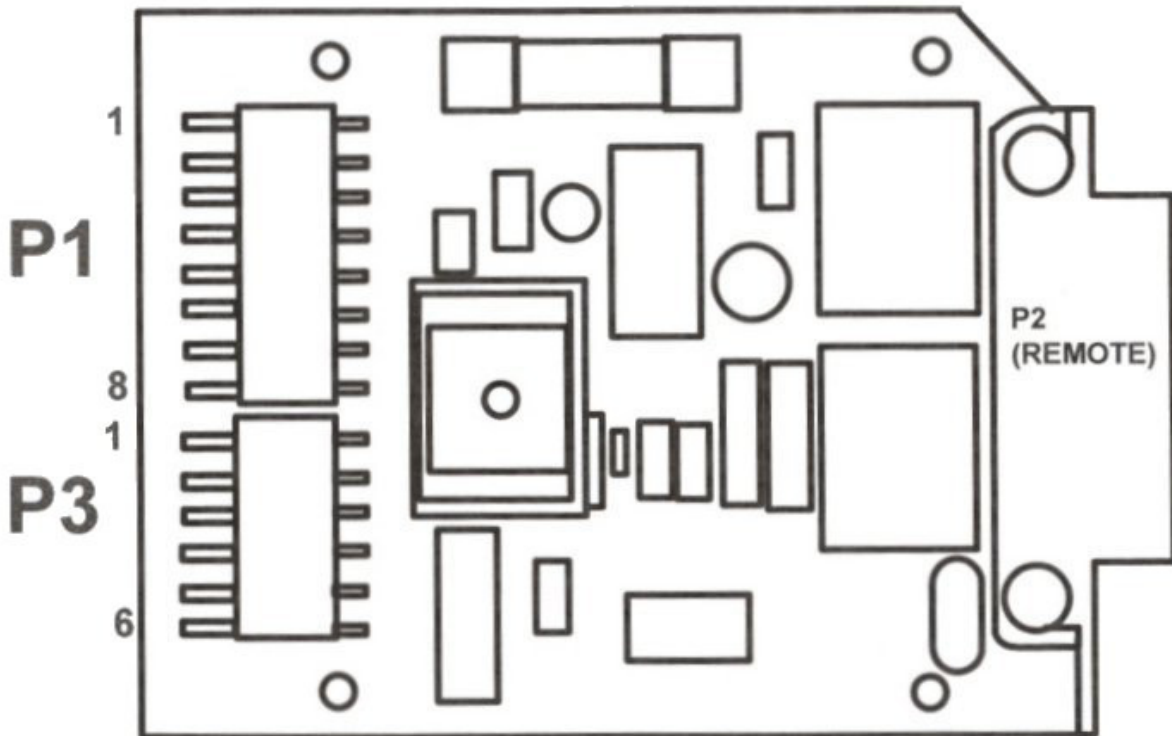

300-3056/3687 CONTROL BOARD

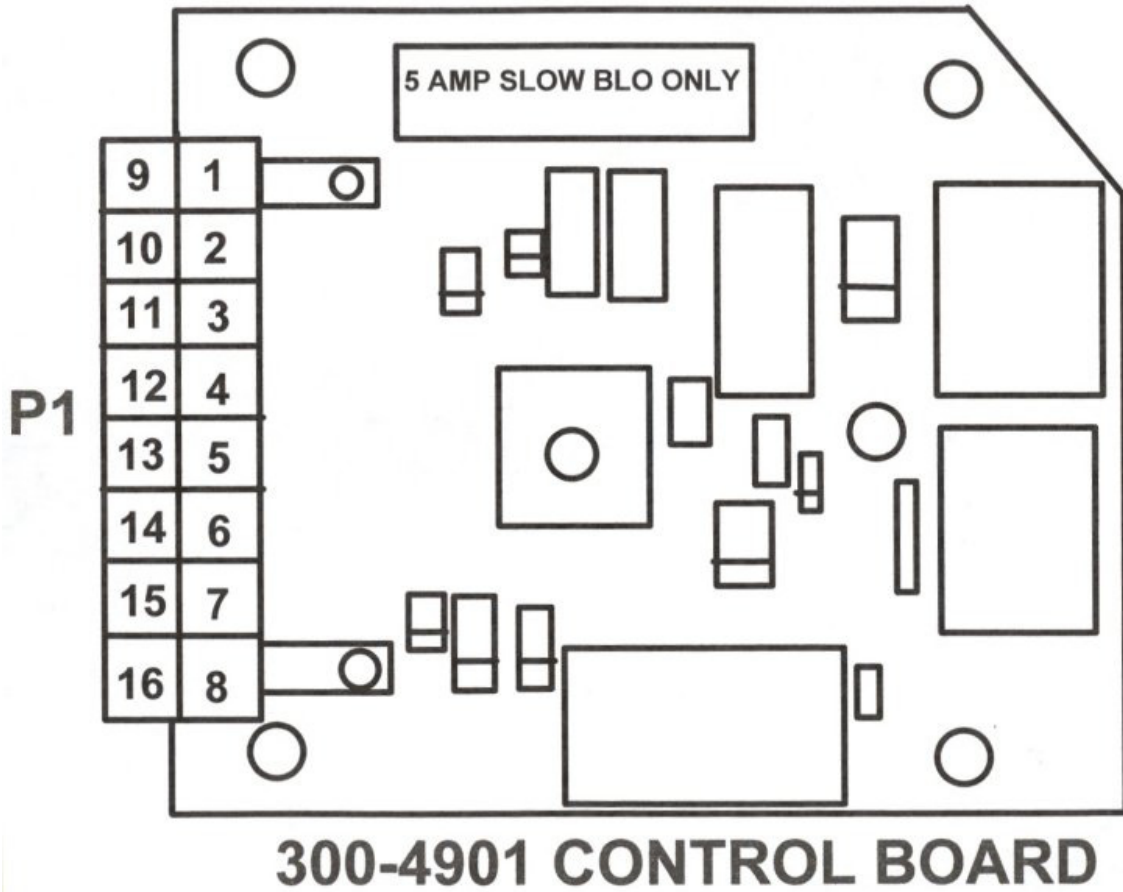
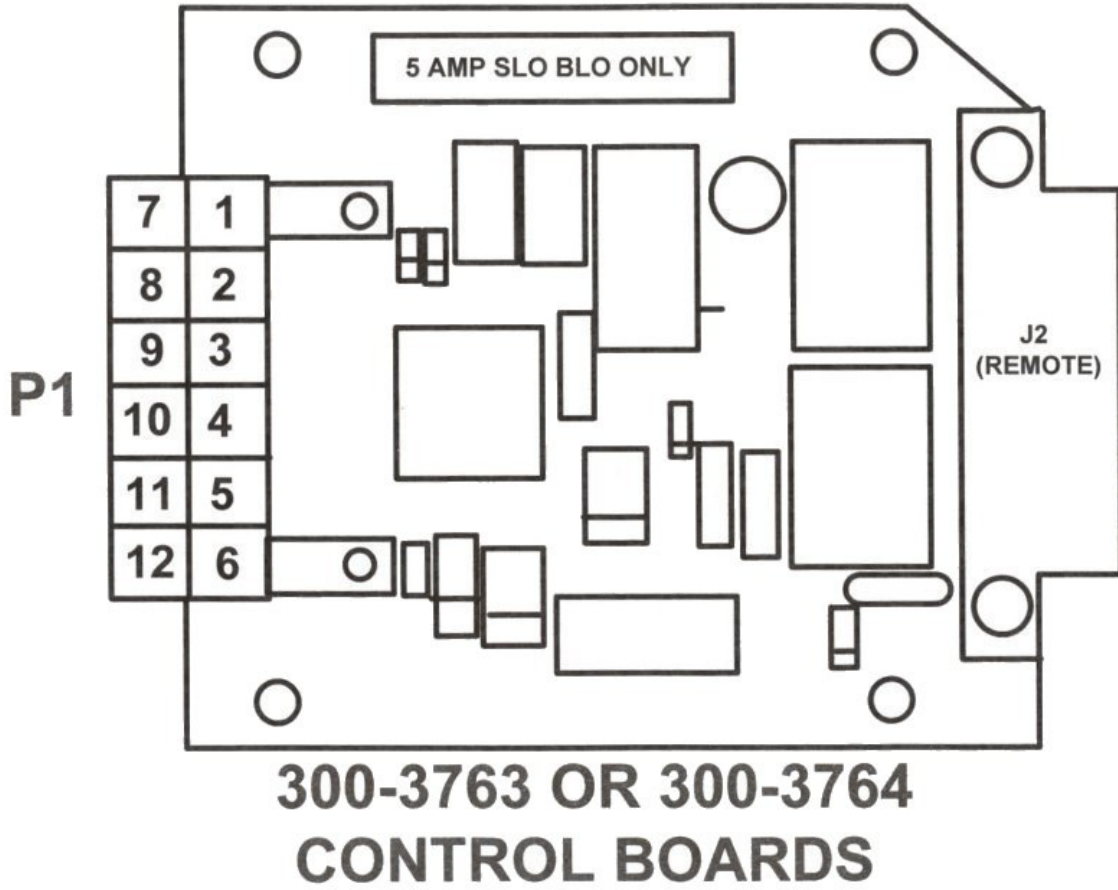

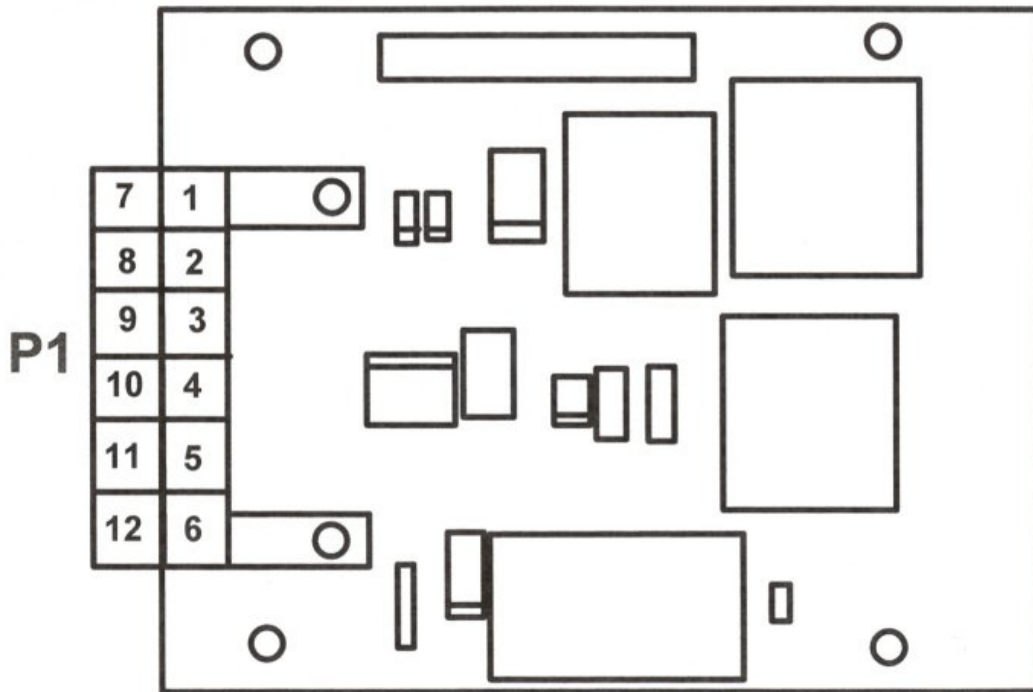

300-4902 CONTROL BOARD

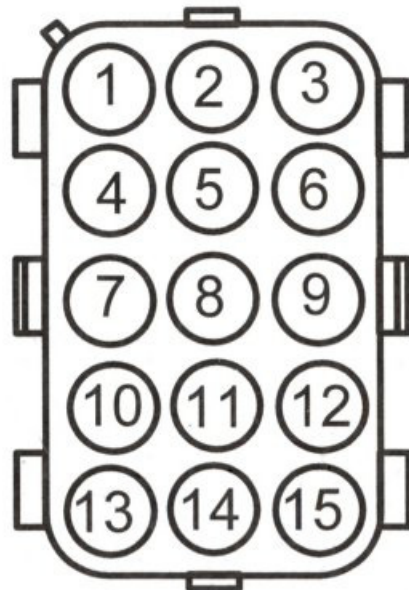

**300-4320
CONTROL BOARD MATING PLUG J1
REAR VIEW (WIRING SIDE)**

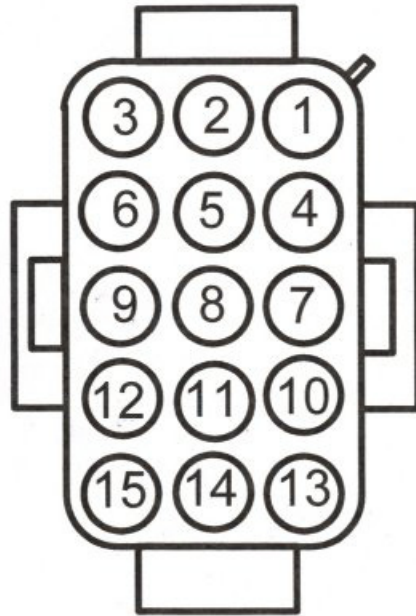

300-4155
 CONTROL BOARD MATING PLUG P1
 REAR VIEW (WIRING SIDE)

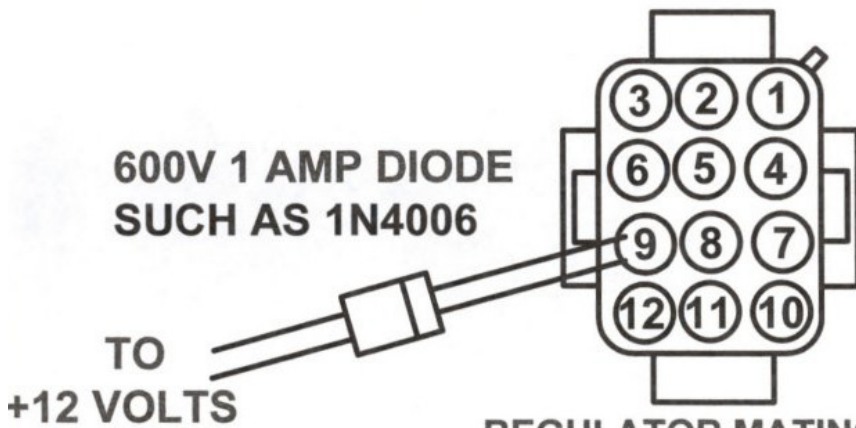

CAUTION:

DO NOT CONNECT 12 VOLTS DIRECTLY TO PIN 9. OVER 200V PRESENT WHEN THE GENERATOR VOLTAGE BUILDS UP.

REGULATOR MATING PLUG
 REAR VIEW (WIRING SIDE)
 APPLICATION OF EXTERNAL
 FIELD FLASH USING DIODE

