

YCB ALTERNATOR MAJOR SERVICE MANUAL

TABLE OF CONTENTS

Introduction	2
Safety Precautions	3
Specifications	4
Description	6
Alternator Disassembly	7
Alternator Troubleshooting	8
Procedures	9
Wiring Diagrams	
120 Volt, Receptacles in End Bell	15
120/240 Volt, Receptacles in End Bell	16
60 Hertz, Remote Receptacles	17
50 Hertz, Remote Receptacles	18
Remote Receptacle Box with Fuses	19

WARNING

TO AVOID POSSIBLE PERSONAL INJURY OR
EQUIPMENT DAMAGE, AN AUTHORIZED SER-
VICE REPRESENTATIVE MUST PERFORM ALL
SERVICE.

INTRODUCTION

INTRODUCTION

This manual provides troubleshooting and repair information for Onan YCB alternators. It is intended to provide service personnel or Onan distributors with simple, to-the-point procedures for repairing the alternator. This information is not applicable to the prime mover; refer to the engine manufacturer's manual for engine information (Briggs or Tecumseh).

TEST EQUIPMENT

Most tests outlined in this manual can be made with an AC-DC multimeter, such as a Simpson 270. Other suggested instruments are:

- Onan multitester 420-0303
- Wheatstone or Kelvin bridge—(Testing Resistance Values below 1 ohm)
- Jumper Wires

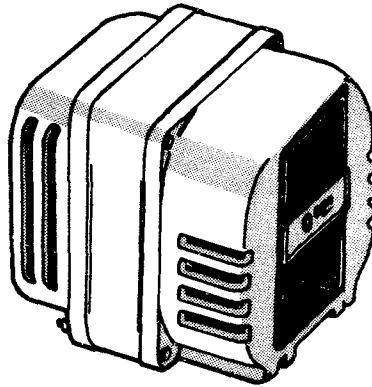

FIGURE 1. YCB ALTERNATOR

SAFETY PRECAUTIONS

The following symbols in this manual signal potentially dangerous conditions to the operator or equipment. Read this manual carefully. Know when these conditions can exist. Then, take necessary steps to protect personnel as well as equipment.

WARNING Onan uses this symbol throughout this manual to warn of possible serious personal injury.

CAUTION This symbol refers to possible equipment damage.

GUARD AGAINST ELECTRIC SHOCK

Remove electric power before removing protective shields or touching electrical equipment. Use rubber insulative mats placed on dry wood platforms over floors that are metal or concrete when around electrical equipment. Do not wear damp clothing (particularly wet shoes) or allow skin surfaces to be damp when handling electrical equipment.

Jewelry is a good conductor of electricity and should be removed when working on electrical equipment.

Use extreme caution when working on electrical components. High voltages cause injury or death.

Follow all state and local electrical codes. Have all electrical installations performed by a qualified licensed electrician.

PROTECT AGAINST MOVING PARTS

Avoid moving parts of the unit. Loose jackets, shirts or sleeves should not be permitted because of the danger of becoming caught in moving parts.

Make sure all nuts and bolts are secure. Keep power shields and guards in position.

If adjustments *must* be made while the unit is running, use extreme caution around hot manifolds, moving parts, etc.

Do not work on this equipment when mentally or physically fatigued.



SPECIFICATIONS

ONAN YCB ALTERNATOR

DESIGN: Revolving field, two pole, compound wound for improved voltage regulation. Self-excited. Drip proof construction. Connected directly to the engine and permanently aligned.

BEARING: Prelubricated, double-sealed needle bearing.

EXCITER: Isolated exciter winding, silicon diodes—no commutator. Collector rings and brushes carry rectified excitation current only to the field coils.

INSULATION: Class F per NEMA MG1-1.65 definition. Insulating varnish conforms to MIL-I-24092, Type M, Class 155.

TEMPERATURE RISE: Temperature rise at rated load is within NEMA MG1-22.40 definition.

COOLING: Direct drive centrifugal blower. Air required 67-cfm.

ROTOR: Laminated steel stack, press fitted to shaft. Heavy polyester with insulated copper wire field coils. Balanced.

STATOR: Laminated electrical steel welded stack. Machine wound and laced AC windings in class F slot liners.

BRUSHES: Electrographitic. Long life, easily serviced.

COLLECTOR RINGS: Sintered copper alloy, concentric annular rings molded in phenolic.

UNIT PERFORMANCE

BATTERY CHARGING CIRCUIT: Alternator winding attached to the connector. Simplifies customer installation of optional battery charger. Output is 12 volts at 8 amperes maximum.

FREQUENCY REGULATION: 3 hertz maximum, no load to rated load.

VOLTAGE REGULATION: $\pm 4\%$.

ELECTRICAL DATA

60 HZ MODELS

GENERATOR SET SERIES**	WATTS	AMPERES	VOLTAGE*	RPM	PHASE
PD TM	1200	10	120	3600	1
PC TN	1750	14.6	120	3600	1
PE TP	2000	16.7	120	3600	1
PF TR	3000	25/12.5	120/240	3600	1
PG TS	4500	38/19	120/240	3600	1
PH TT	5500	45.8/22.9	120/240	3600	1

50 HZ MODELS

GENERATOR SET SERIES**	WATTS	AMPERES	VOLTAGE	RPM	PHASE
PD TM	1000	10/5	100/200	3000	1
	1000	9/4.5	110/220	3000	1
	1000	8.4/4.2	120/240	3000	1
PC TN	1400	14/7	100/200	3000	1
	1400	12.6/6.3	110/220	3000	1
	1400	11.6/5.8	120/240	3000	1
PE TP	1600	16/8	100/200	3000	1
	1600	14.4/7.2	110/220	3000	1
	1600	13.2/6.6	120/240	3000	1
PF TR	2500	25/12.5	100/200	3000	1
	2500	22.8/11.4	110/220	3000	1
	2500	20.8/10.4	120/240	3000	1
PG TS	3700	37/18.5	100/200	3000	1
	3700	33.6/16.8	110/220	3000	1
	3700	30.8/15.4	120/240	3000	1
PH TT	4500	45/22.5	100/200	3000	1
	4500	41/20.5	110/220	3000	1
	4500	37.5/18.7	120/240	3000	1

* - Some nameplates are stamped 125/250.

** - First letter "P" designates alternator is driven by a Briggs and Stratton engine; "T"—driven by Tecumseh engine.

DESCRIPTION

ALTERNATOR DESIGN

The YCB alternator is a two pole, revolving field unit, driven by a 3600 rpm engine. The alternator has an isolated exciter winding, with silicon diodes for rectifying AC to DC. Collector rings and brushes carry rectified current to the revolving field coils.

The alternator's power source is the stator, with the rotor being the magnetic field. Current is taken from the stator assembly, through a connector plug on end bell and finally to the receptacles.

RECEPTACLES

Alternator Mounted Receptacles

Two, 120 volt duplex receptacles, mounted on end bell, are standard equipment on all 120 volt only models. 120/240 volt models have one, 120 volt duplex receptacle and one, 240 volt duplex receptacle as standard equipment.

120 VOLT RECEPTACLES

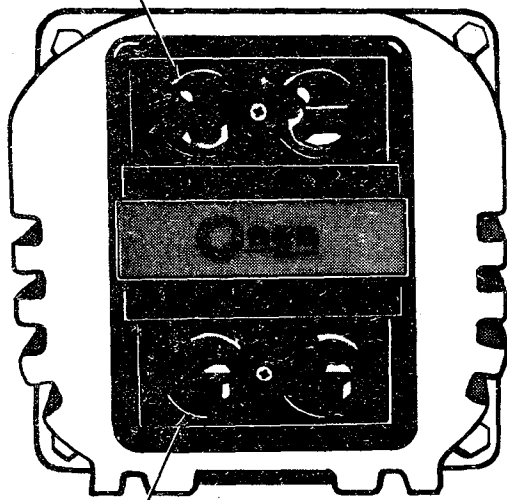

240 RECEPTACLES

FIGURE 2. 120/240 VOLT RECEPTACLES

Externally Mounted Receptacles (Optional)

External receptacles have one, 120 volt, 15 amp duplex receptacle; one, 120 volt, 30 amp receptacle and one, 240 volt, 20 amp receptacle. Receptacle boxes may also be equipped with three fuses which correspond to the ampere rating of each receptacle. Alternators with externally mounted receptacles have a blank cover on the end bell (rather than receptacles).

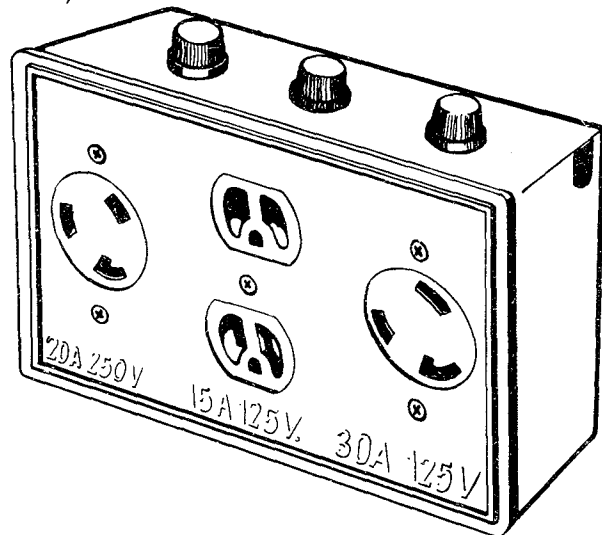

FIGURE 3. EXTERNAL RECEPTACLE BOX

12 VOLT BATTERY CHARGER (Optional)

Some models may be equipped with a 12 volt, fused battery charger. This charger operates off a separate alternator winding and charges at 5-8 amps.

VOLTMETER AND INDICATOR LAMP (Optional)

All 120 volt models may use a voltmeter (0-150 volts) mounted between the two duplex receptacles. A green scale on the voltmeter shows proper operating voltage. Voltmeter is standard equipment on two bearing alternators; the indicator lamp shows the operator that there is a voltage present at the receptacle.

ALTERNATOR DISASSEMBLY

ALTERNATOR DISASSEMBLY

1. Remove receptacle cover or blank cover from end bell.
2. Remove screws securing brushes and slide brushes from their holders.

CHECK BRUSH WEAR AT THIS TIME.

3. Unfasten and remove four long capscrews, lockwashers and nuts that fasten end bell, stator and generator adapter together. Pull end bell straight out from stator while unfastening connector plug between stator and end bell. Place end bell aside.

ALL PARTS INSIDE OF END BELL INCLUDING DIODES, CAPACITOR, RECEPTACLES, BEARING, WIRES AND CONNECTIONS CAN BE TESTED AT THIS TIME. ROTOR, STATOR AND COLLECTOR RINGS CAN ALSO BE CHECKED OR TESTED AT THIS TIME WITHOUT FURTHER DISASSEMBLY.

4. Pull stator straight out from alternator, being careful not to lay its weight directly on the rotor.
5. Remove internal allen screw and sleeve from rotor shaft. Tap rotor gently with a soft-faced hammer (brass or lead) to loosen rotor from the tapered engine shaft. When loose, pull straight out over rotor through stud.
6. Remove rotor through stud.
7. Some models use a tapered adapter shaft. Remove this if used.
8. Remove four capscrews securing alternator adapter, then remove adapter.
9. Alternator assembly is the reverse of disassembly, following torque values given below:

ASSEMBLY TORQUES

Diodes (End Bell)..... 12-15 in. lb.
 End Bell to Stator Through Bolts (4)..... 5-8 ft. lb.
 Rotor Through Stud Nut (Allen Screw) 10-15 ft. lb.

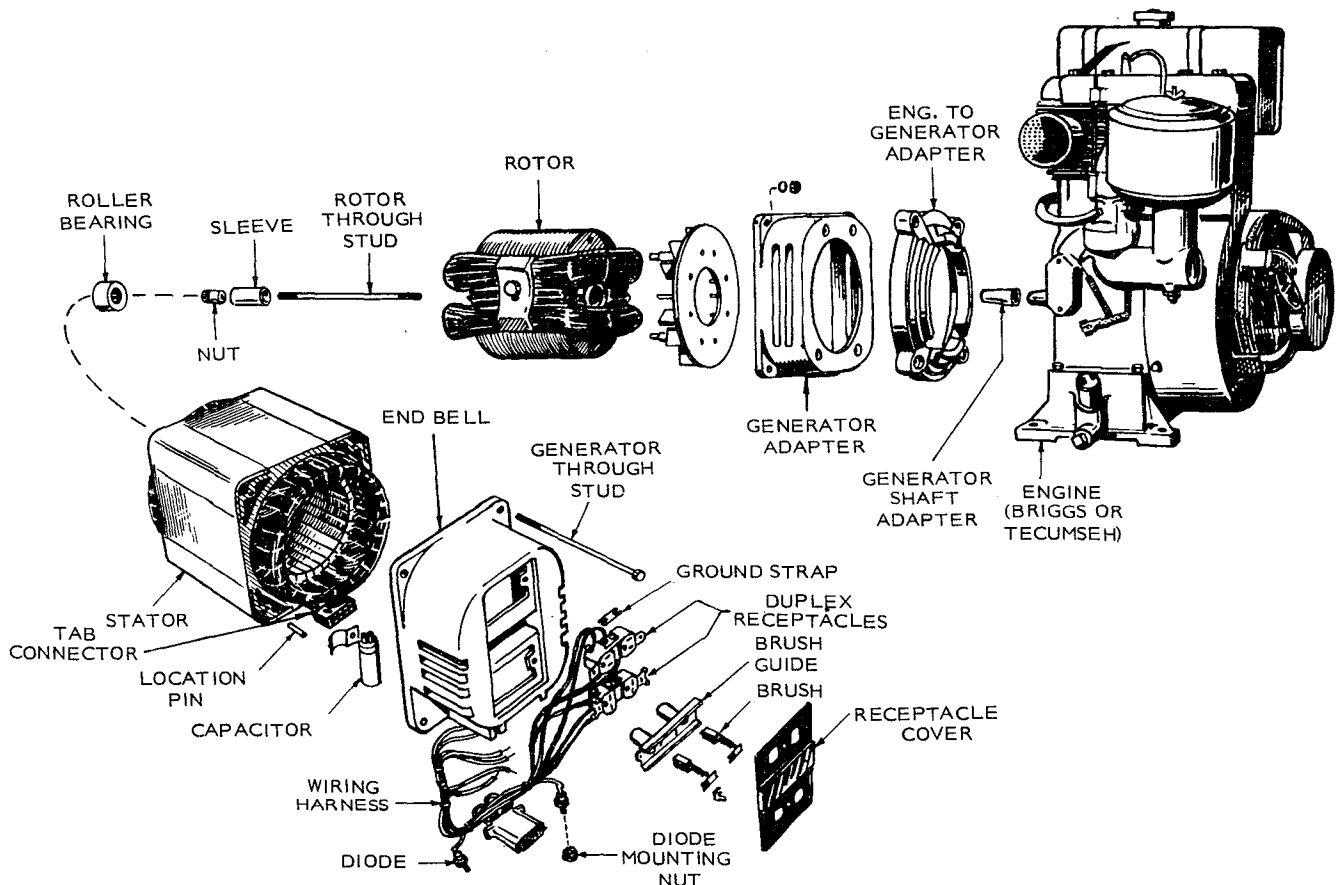

FIGURE 4. EXPLODED VIEW OF ALTERNATOR

ALTERNATOR TROUBLESHOOTING

TROUBLE	CAUSE	PROCEDURE*
No Output	<ol style="list-style-type: none"> 1. Open Fuse(s) in receptacle box 2. Faulty receptacle 3. Brushes worn excessively 4. Brushes sticking or broken spring 5. Loss of residual 6. Dirty Collector Rings 7. Loose or broken wire 8. One or both diodes shorted 9. Faulty capacitor 10. Faulty rotor 11. Faulty stator 	<p>E D A A C A B F G H J</p>
Low Output	<ol style="list-style-type: none"> 1. Alternator speed too low 2. Engine low on power 3. Worn brushes 4. One open diode 5. Open Capacitor 6. Rotor windings shorted 7. Stator windings shorted 	<p>A F G H J</p>
Alternator Overheats	<ol style="list-style-type: none"> 1. Overloaded 2. Alternator air intake plugged with dirt, leaves, etc. 3. Windings covered with dirt or oil 	<p>E clean clean</p>

* - Letter in this column denotes a separate procedure corresponding to letter; follows in *Procedures* section.

PROCEDURES

[A]

ALTERNATOR BRUSHES

To inspect the brushes, refer to Figure 5 and the following:

1. Remove cover plate on end bell.
2. Unfasten brush mounting (Phillips) screws.
3. Slide brushes out of their holders.
4. Replace if worn to 5/16 inch or less.

Use only the replacement brushes specified in the parts catalog. Other brushes may have entirely different electrical characteristics. Be sure brushes slide freely in their holders, without any binding.

If collector rings are rough, smooth the ring surfaces with #240 sandpaper. Do not use emery cloth.

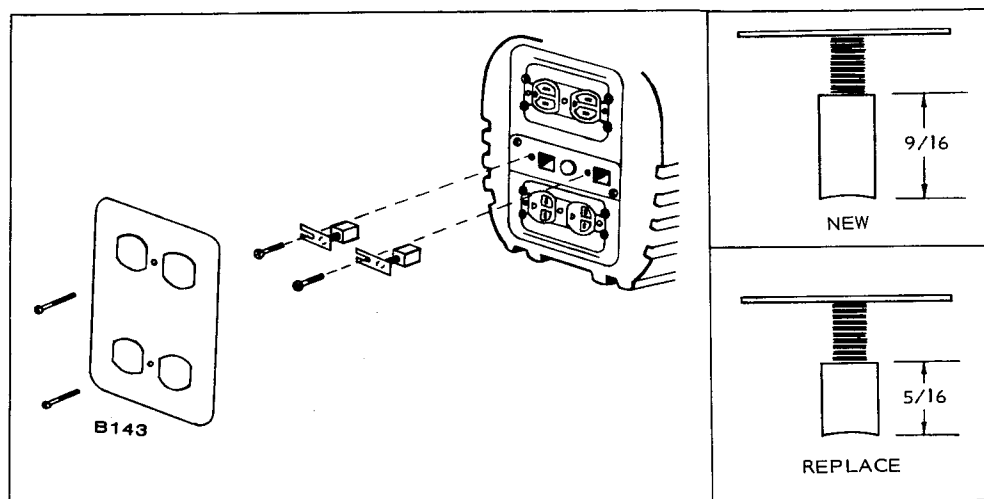

FIGURE 5. ALTERNATOR BRUSHES

[B]

BROKEN WIRE OR LOOSE CONNECTION

Check all wires for bad connections. Check especially around receptacles, diodes, capacitor and terminal connections.

[C]

LOSS OF RESIDUAL (Flashing the Field)

If there is a loss of residual (voltage will not build up), it may be necessary to flash the field.

1. Remove receptacle plate (or blank cover) from end bell.
2. Connect a 6 volt lantern battery with leads as shown in Figure 6.
3. Start unit with no load connected to alternator.
4. Momentarily touch positive brush with positive (+) lead of lantern battery while grounding the negative (-) lead to generator frame. Remove as soon as voltage starts to build up. (Use a plug-in voltmeter in one of the receptacles if unit is not equipped with a voltmeter.)

Positive brush is on the left side when facing the end bell.

If it is necessary to flash the field daily or each time the generator is used, the problem is most likely a defective capacitor.

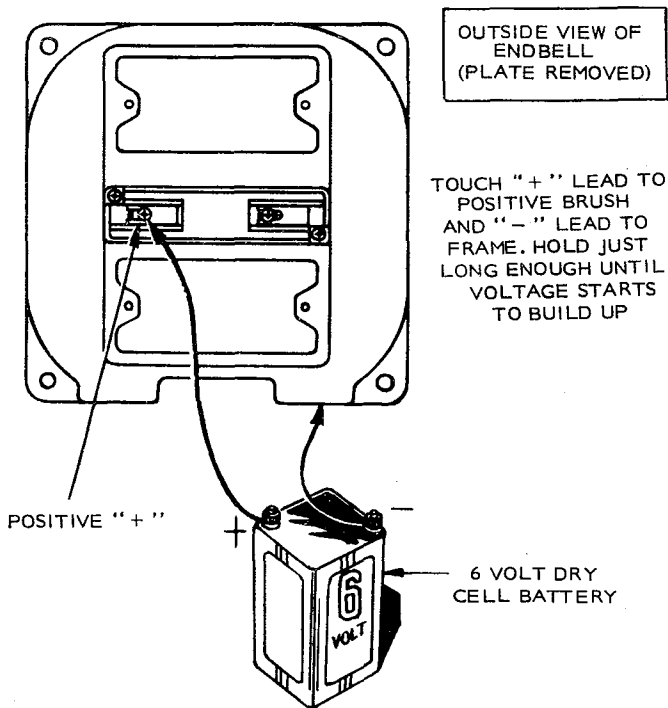

FIGURE 6. FLASHING THE FIELD

[D]

FAULTY RECEPTACLE

Receptacles mounted on the end bell can be removed and replaced without removing the end bell from the generator. Remove receptacle plate (or blank cover), then remove screws on receptacles. Pull straight out to remove receptacles.

WARNING Don't attempt to remove receptacles with unit running. Touching live wires could cause serious injury.

[E]

FUSES

Some models with separate receptacle boxes are equipped with fuses. If fuse is open or blown, turn fuse cover counterclockwise and replace (Figure 7) with an identical fuse. Blown fuses are caused by too much load on the receptacle, or an external short circuit.

CAUTION Don't exceed current rating stamped below receptacles. Be sure to replace with the correct rated fuse to avoid damage to power tools.

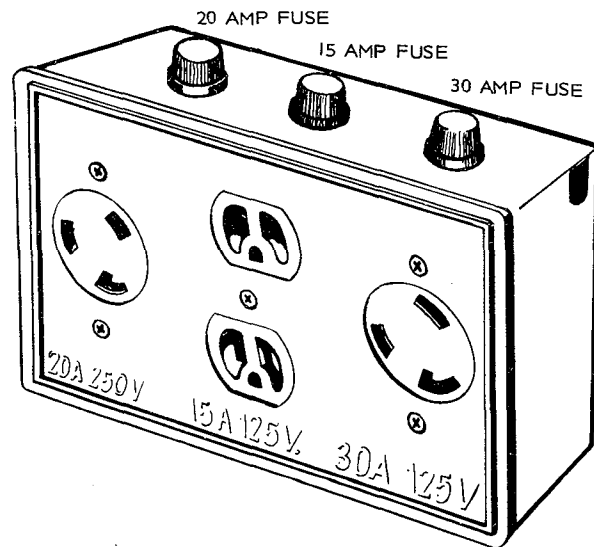

FIGURE 7. FUSE REPLACEMENT

[F]

DIODES

Diodes can be tested without removing from end bell or disconnecting wires, provided connector plug is disconnected from stator.

Unsolder and remove each diode from end bell before testing. Diode location is shown in Figure 8. Using an accurate ohmmeter, connect one lead to each end of diode and observe resistance reading. Reverse ohmmeter leads and again observe resistance readings (Figure 9).

A good diode should have a higher reading in one direction than the other. If both readings are high, or low, diode is defective and must be replaced with a new, identical part.

CAUTION When unsoldering or soldering wire to diode, hold a needle-nose pliers (Figure 10) between diode terminal and soldering point to prevent heat from destroying diode.

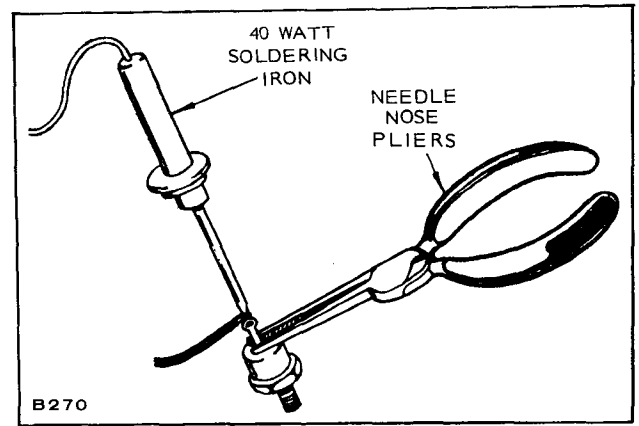

FIGURE 10. SOLDERING DIODE LEAD

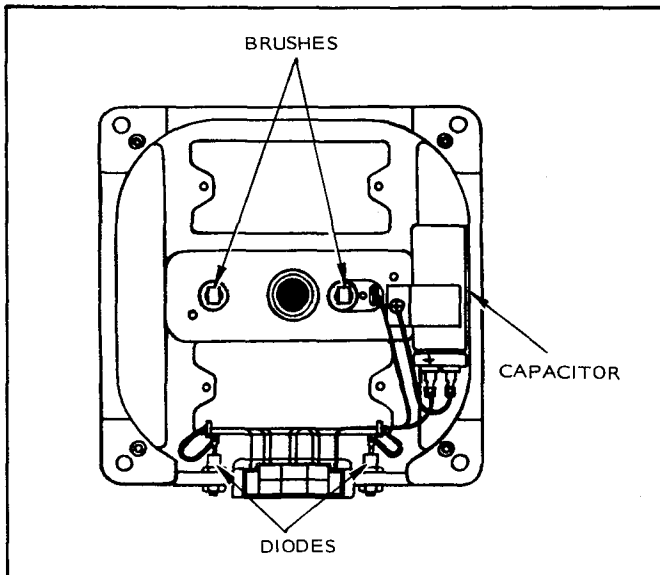

FIGURE 8. DIODE LOCATION

[G]

CAPACITOR

Capacitor is located in end bell (Figure 8). A defective capacitor will not allow voltage to build up until field is flashed (Procedure C). If generator set is running at a constant speed (no fluctuation) but voltage rises and falls, the capacitor may also be defective. If suspecting a defective capacitor, replace with one known to be good.

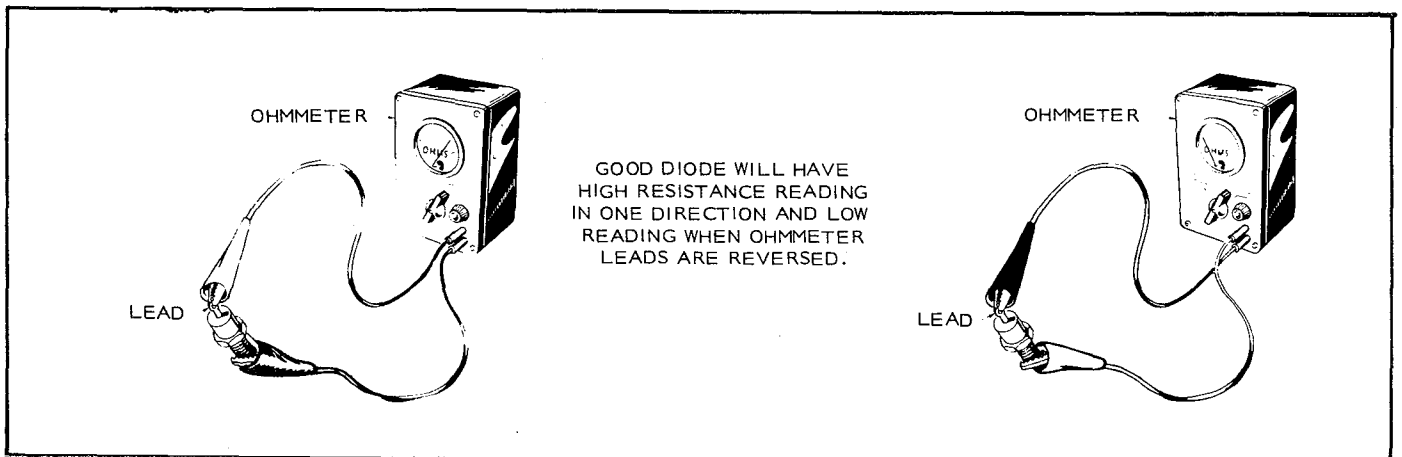

FIGURE 9. TESTING DIODES

[H]

TESTING ROTOR WINDINGS

Testing Winding Resistances

Use an accurate ohmmeter for this test. Touch meter leads to each collector ring (Figure 11). Resistances should be within the values specified in Table 1. Readings are taken at 68F (20C).

Testing for Grounds

Connect an ohmmeter from each collector ring to rotor shaft (ground). If rotor is serviceable, there should be *no* reading on ohmmeter (Figure 11).

If either of the above tests do not comply, replace with a new rotor.

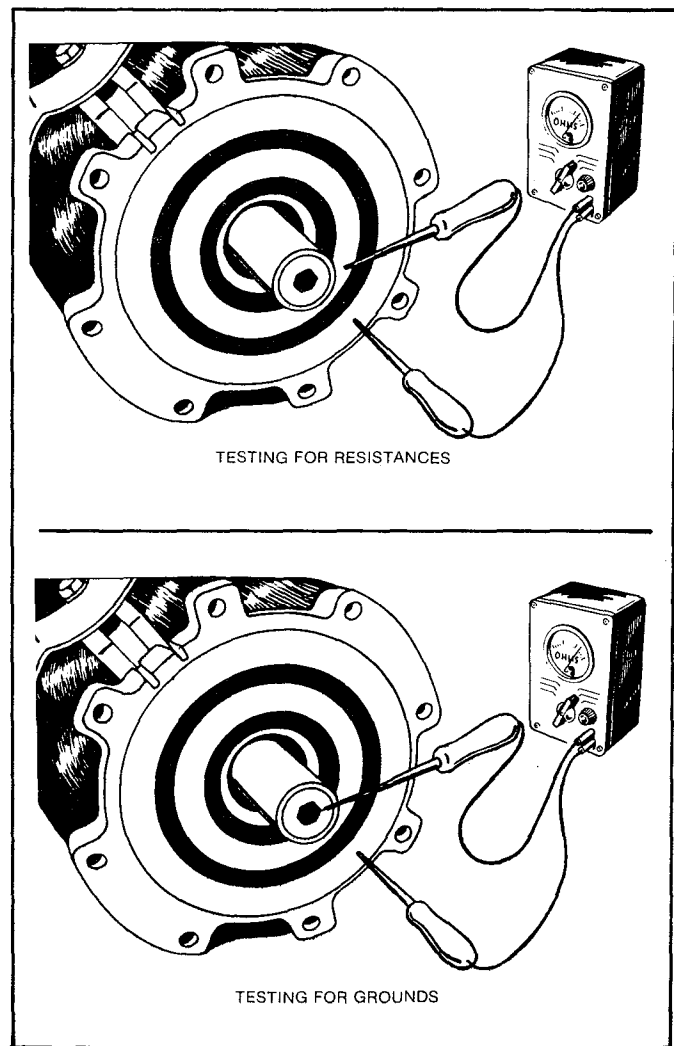

FIGURE 11. TESTING ROTOR WINDINGS

TABLE 1. RESISTANCE VALUES FOR ROTORS

WATTS	STACK LENGTH	*ROTOR RESISTANCE
UP TO 1200	1-1/2"	25.7-31.5 Ohms
1201-2000	2-1/4"	18.5-22.6 Ohms
2001-3000	3"	21.0-25.6 Ohms
3001-4500	4-1/2"	26.2-32.0 Ohms
4501-6000	6"	31.0-37.9 Ohms

* Measured between collector rings.

[J]

TESTING STATOR WINDINGS

Check stator windings by connecting ohmmeter leads between terminals on stator plug. Figure 12 shows location of terminals on single and three phase units.

A Wheatstone or Kelvin bridge is required for testing low resistance values (below 1 ohm).

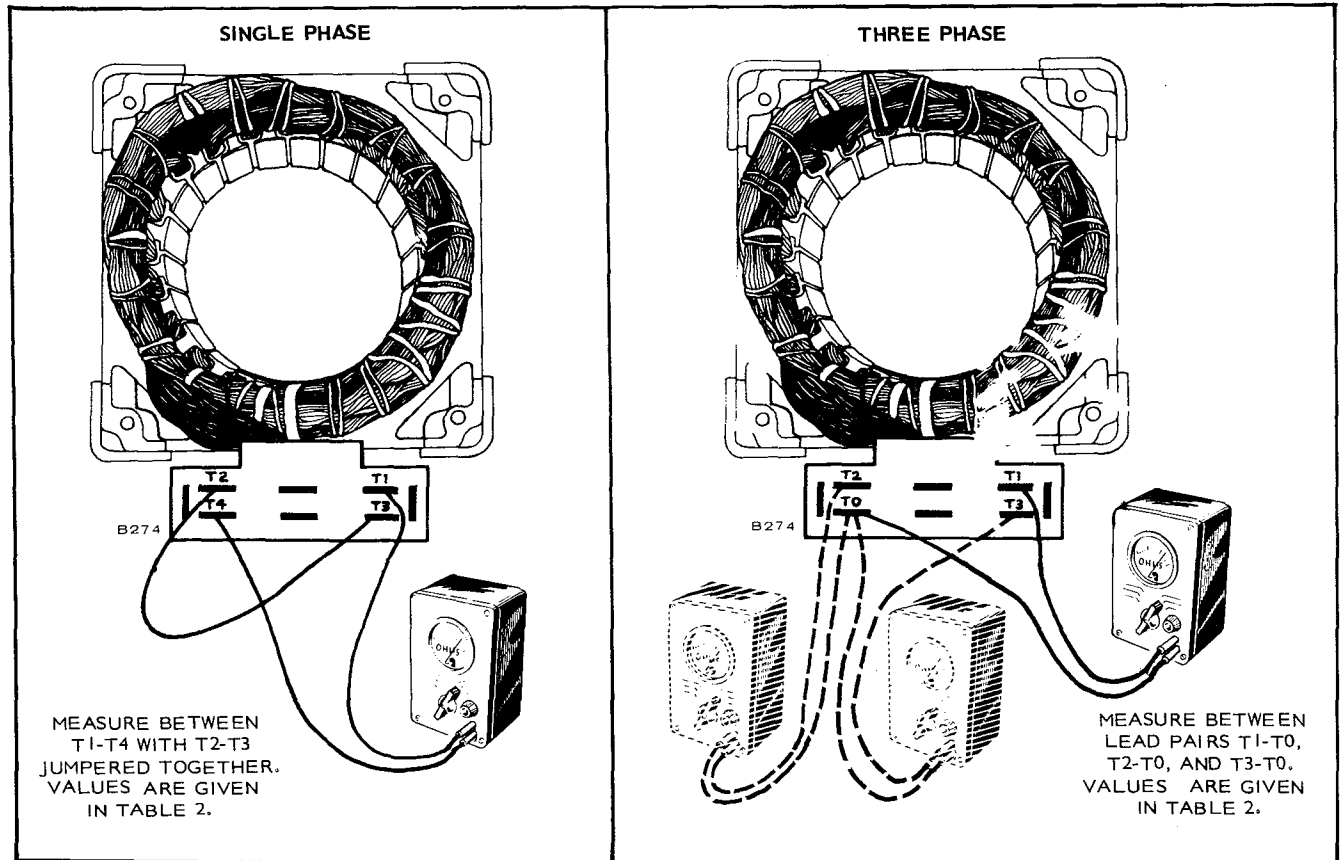

FIGURE 12. TESTING STATOR WINDINGS

TABLE 2. RESISTANCE VALUES FOR STATOR WINDINGS

RATING OF ALTERNATOR IN WATTS	STACK LENGTH	RESISTANCE (OHMS)	
		60 HERTZ	50 HERTZ
Up to 1200	1-1/2"	2.57-3.30 Ohms	2.56-4.54 Ohms
1201-2000	2-1/4"	1.22-1.57 Ohms	1.22-2.15 Ohms
2001-3000	3"	0.75-0.96 Ohms	0.75-1.32 Ohms
3001-4500	4-1/2"	0.37-0.47 Ohms	0.37-0.66 Ohms
4500-6000	6"	0.25-0.33 Ohms	0.25-0.93 Ohms

[K]

EXCITER WINDINGS

Check exciter windings by connecting ohmmeter across X1 and X2 on stator plug. Exciter resistance values are shown in Table 3; location of X1 and X2 are shown in Figure 13.

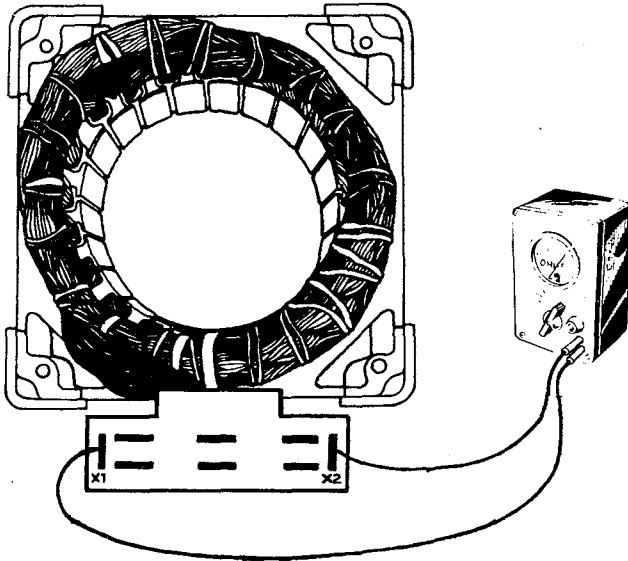

FIGURE 13. TESTING EXCITER WINDINGS

TABLE 3. RESISTANCE VALUES FOR EXCITER WINDINGS

RATING OF ALTERNATOR IN WATTS	STACK LENGTH	RESISTANCE (OHMS)	
		60 HERTZ	50 HERTZ
Up to 1200	1-1/2"	2.04-3.30 Ohms	4.10-5.02 Ohms
1201-2000	2-1/4"	1.54-2.75 Ohms	3.11-3.71 Ohms
2001-3000	3"	1.54-2.31 Ohms	2.07-2.53 Ohms
3001-4500	4-1/2"	1.29-2.20 Ohms	1.98-2.42 Ohms
4500-6000	6"	1.14-2.20 Ohms	1.98-2.42 Ohms

601-0203

GENERATOR
STATOR

END BELL

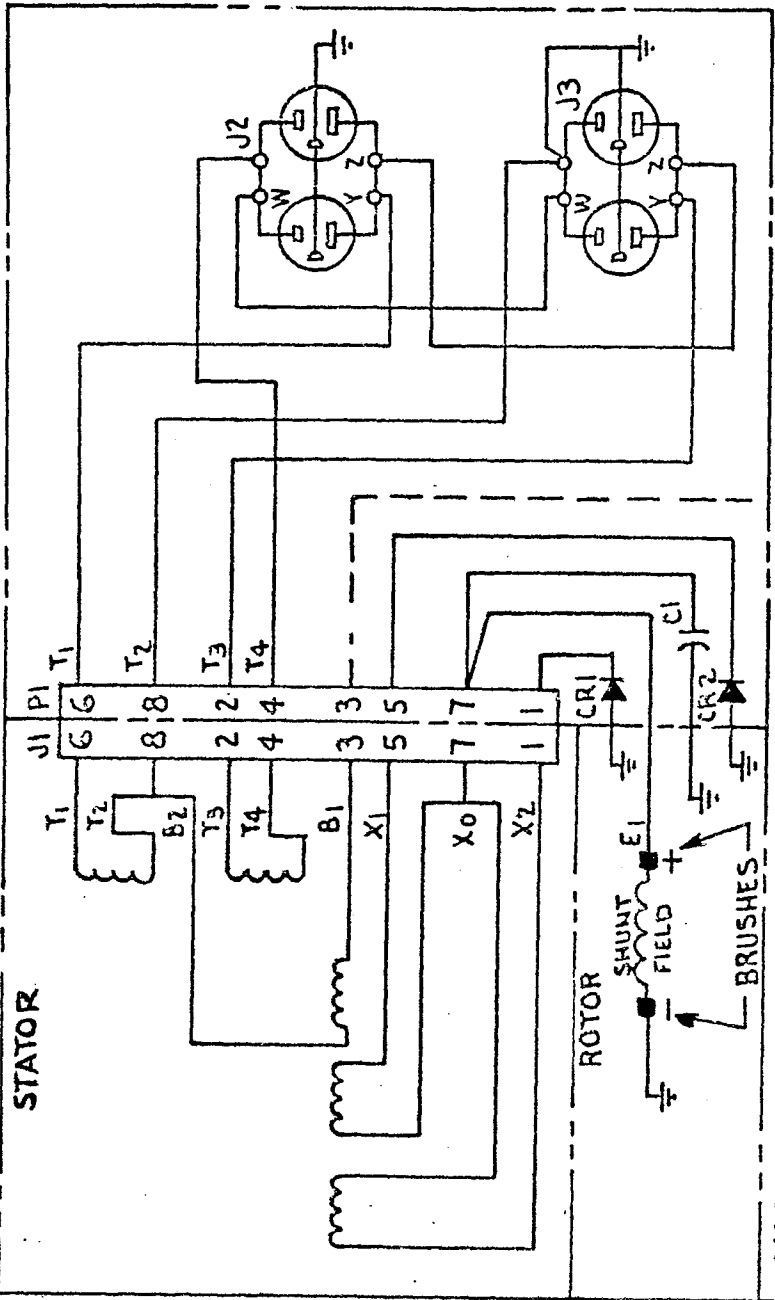

120V, 15A RECEPTACLE

120V, 15A RECEPTACLE

BATTERY
CHARGER
(OPTIONAL)

MAGNETO ASSY

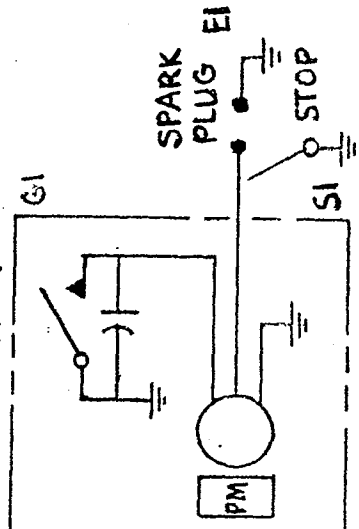

120 VOLT, RECEPTACLES IN END BELL

REF PART NUMBER DES	QTY	DESCRIPTION
C1 356-0056	1	CAPACITOR
CR1 358-0015	2	RECTIFIER-DIODE
E1		SPARK PLUG
G1		MAGNETO ASSY
J1 323-0849	1	CONNECTOR
J2,3 323-0383	2	RECEPTACLE DUPLEX
P1 323-0848	1	CONNECTOR
S1		SWITCH STOP

601-0204

GENERATOR
STATOR

END BELL

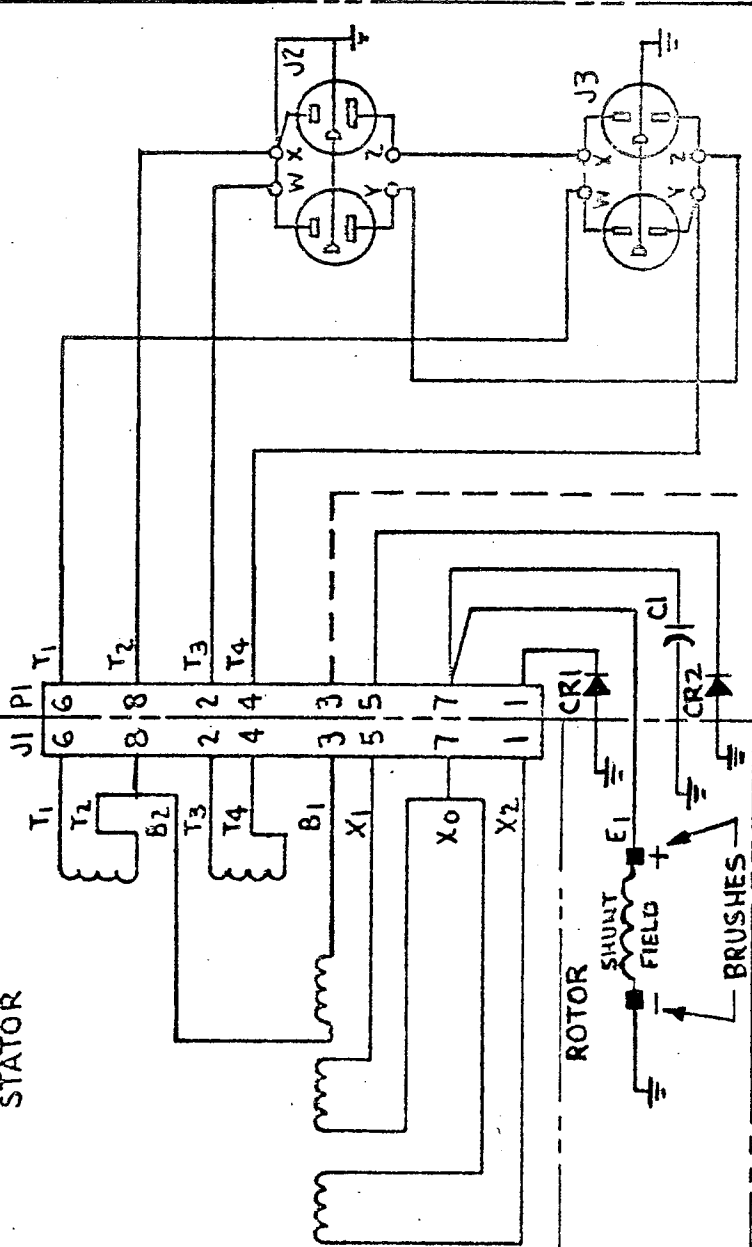

120V, 15A RECEPTACLE

240V, 15A RECEPTACLE

MAGNETO ASSY

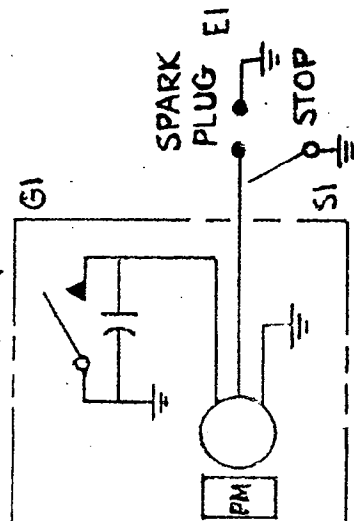

BATTERY CHARGER (OPTIONAL)

REF DES	PART NUMBER	DRW SIZE	QTY	DESCRIPTION
C1	356-0056	-	1	CAPACITOR (REF)
CR1	358-0015	-	2	RECTIFIER-DIODE (REF)
E1				SPARK PLUG (REF)
G1				MAGNETO ASSY (REF)
J1	373-0849	-	1	CONNECTOR (REF)
J2	323-0383	P	1	RECEPTACLE DUPLEX(120V)(REF)
J3	323-0213	P	1	RECEPTACLE DUPLEX(240V)(REF)
P1	323-0848	-	1	CONNECTOR (REF)
SI				SWITCH STOP (REF)

120/240 VOLT, RECEPTACLES IN END BELL

601-0205

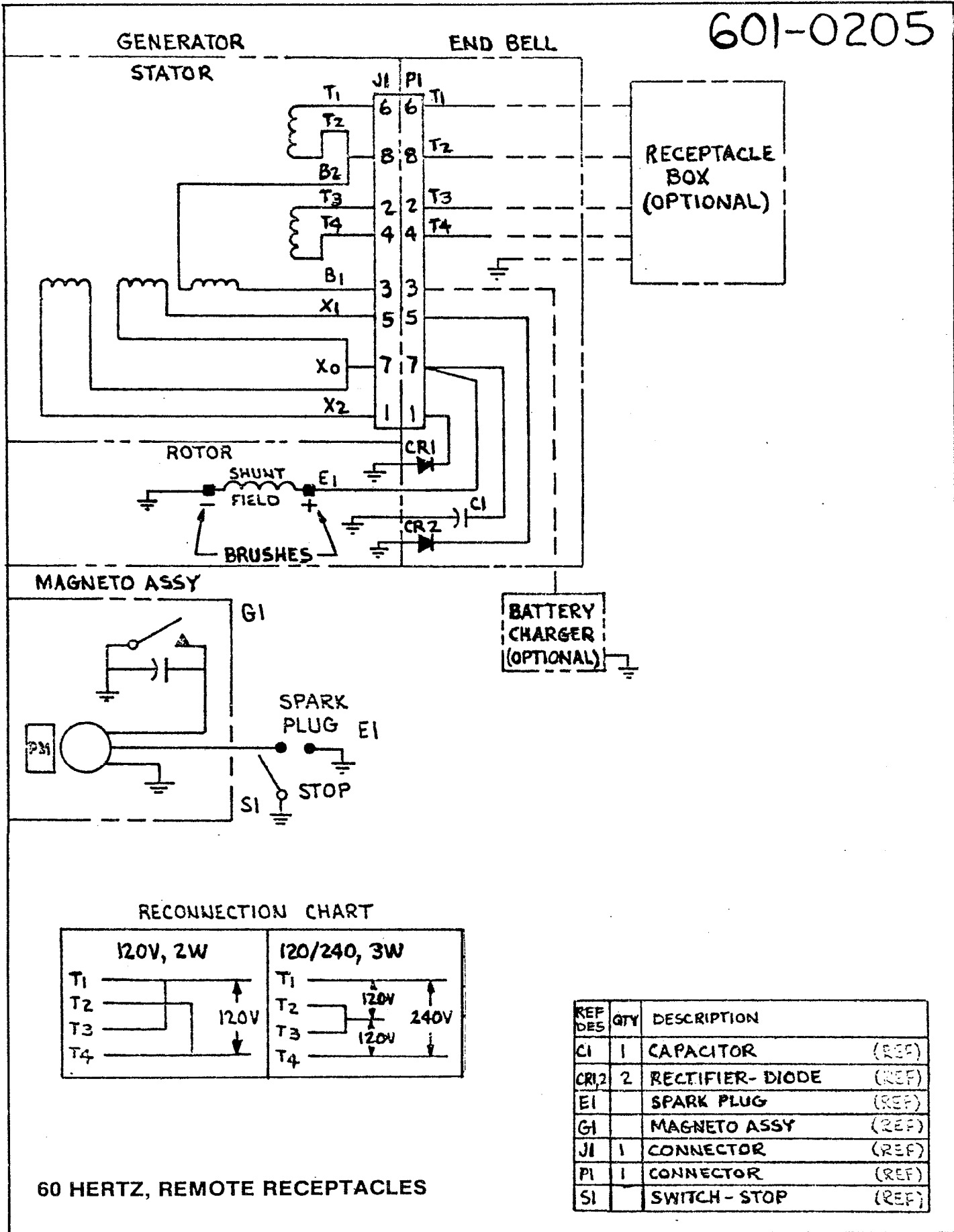

RECONNECTION CHART

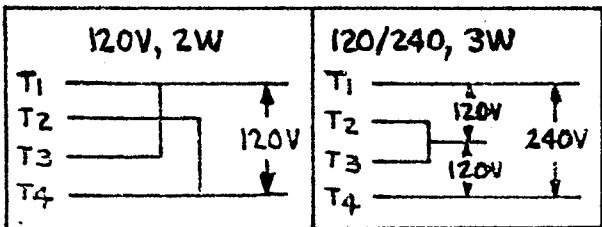

REF DES	QTY	DESCRIPTION
CI	1	CAPACITOR (REF)
CR1,2	2	RECTIFIER-DIODE (REF)
E1		SPARK PLUG (REF)
G1		MAGNETO ASSY (REF)
J1	1	CONNECTOR (REF)
PI	1	CONNECTOR (REF)
SI		SWITCH-STOP (REF)

60 HERTZ, REMOTE RECEPTACLES

601-0207

GENERATOR

END BELL

STATOR

RECEPTACLE BOX

REF DES	DESCRIPTION
CI	CAPACITOR (REF)
CR1	RECTIFIER- DIODE (REF)
EI	SPARK PLUG (REF)
GI	MAGNETO ASSY (REF)
J1	CONNECTOR (REF)
P1	CONNECTOR (REF)
SI	SWITCH- STOP (REF)
	RECEPTACLE BOX
	COVER- RCPT BOX
	BRACKET- RCPT BOX
	BRACKET- RCPT BOX MTG
	WIRING HARNESS

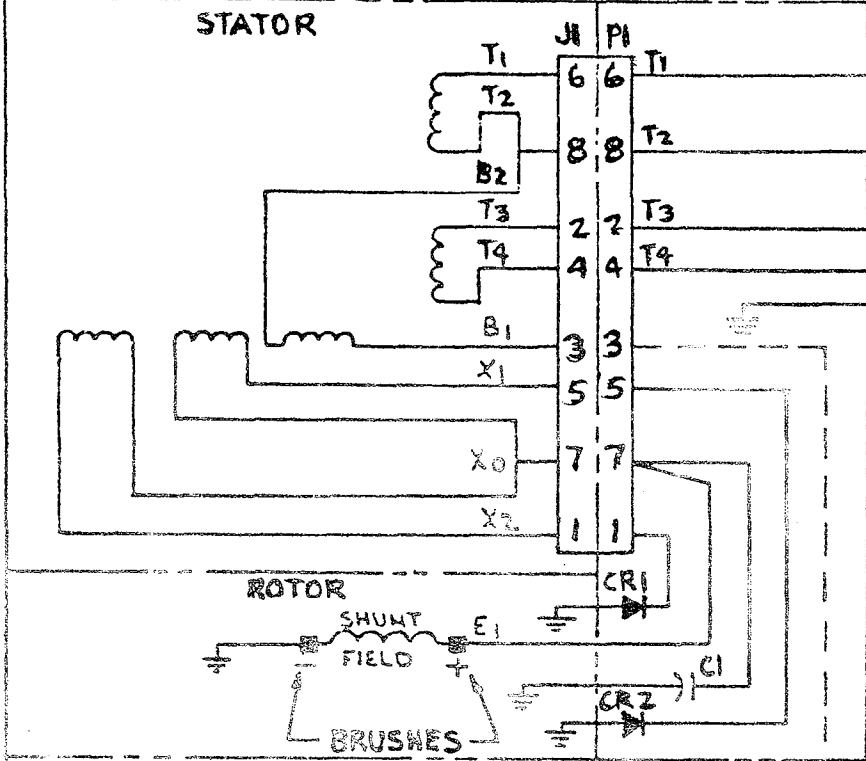

MAGNETO ASSY

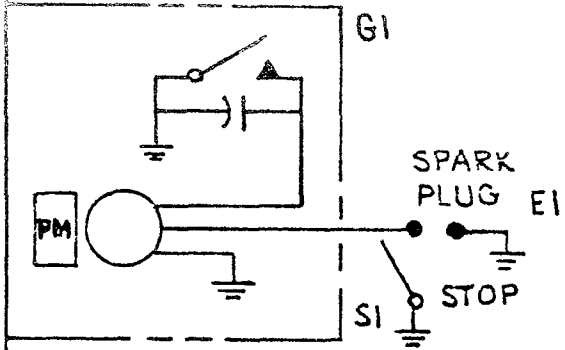

BATTERY CHARGER (OPTIONAL)

50 HERTZ, REMOTE RECEPTACLES

NOTE:
T2 MUST BE GROUNDED

RECONNECTION CHART

53CP 53BP 53AP	X	3W., 50Hz	Y
		2W., 50Hz	120/240 V
	120V	120/240 V	
	110V	110/220 V	
	100V	100/200V	

625-1302

EXISTING GENERATOR

END BELL

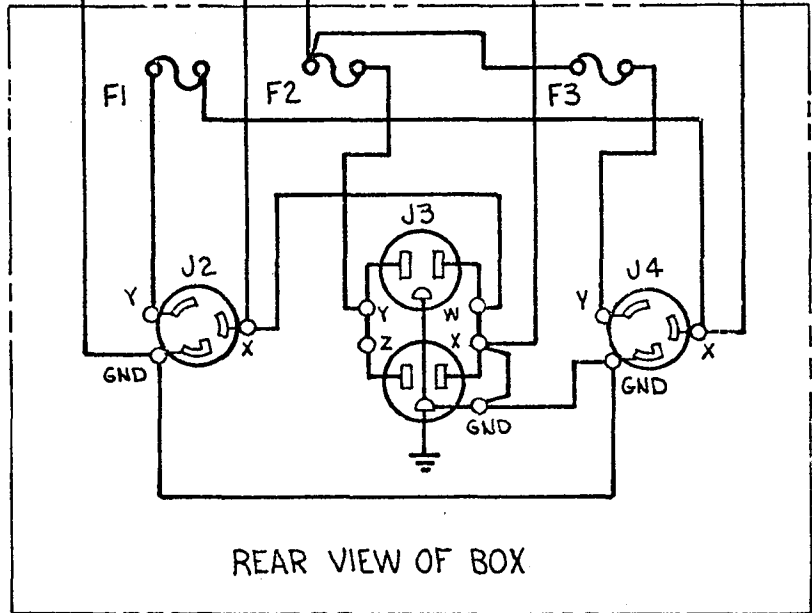
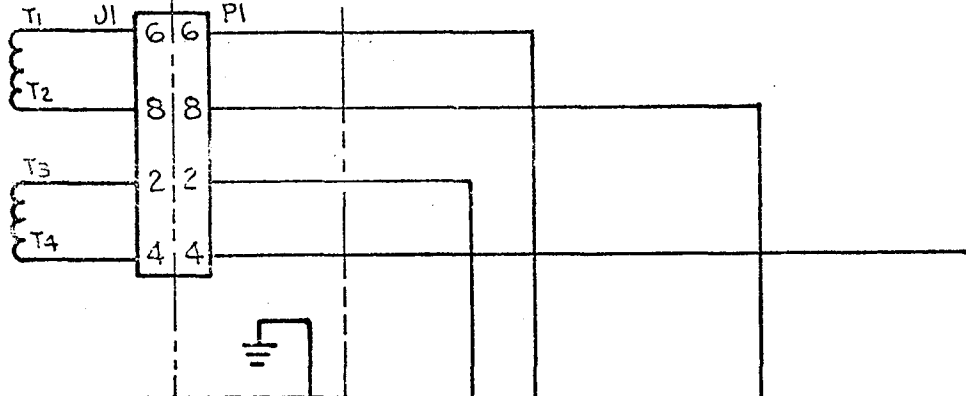

REAR VIEW OF BOX

REMOTE RECEPTACLE BOX WITH FUSES

REF. DES.	QTY	DESCRIPTION
F1	1	FUSE - 30 AMP (REF)
F2	1	FUSE - 15 AMP (REF)
F3	1	FUSE - 20 AMP (REF)
J1	1	CONNECTOR (REF)
J2	1	RCPT-LOCKING (30A, 225V) (REF)
J3	1	RCPT-DUPLEX (15A, 125V) (REF)
J4	1	RCPT-TWIST LOCK (20A, 250V) (REF)
P1	1	CONNECTOR (REF)
	1	RECEPTACLE BOX ASSY W/FUSE

