



Operator Manual

Our energy working for you.™



**Power
Generation**

Controller

PowerCommand 2.2

Table of Contents

SECTION	PAGE
Table of Contents	i
Safety Precautions	v
List of Acronyms	ix
Glossary	xi
1. SYSTEM OVERVIEW	1-1
About this Manual	1-1
Description	1-1
Alternator Connections	1-2
Main Alternator Output	1-2
Permanent Magnet Generator (PMG)	1-2
Exciter (Field Windings)	1-2
Battery-charging Alternator	1-2
High Alternator Temperature Switch	1-2
Engine Connections	1-2
Battery Connections	1-2
Starter	1-2
Engine Control Module (ECM)	1-2
Low Coolant Temperature (LCT) Switch	1-2
Low Coolant Level (LCL) Switch	1-2
Low Coolant Level (LCL) Switch #2	1-2
Low Fuel Level Switch	1-2
Low Fuel in Day Tank Switch	1-2
Rupture Basin Switch	1-2
Fuel Shutoff (FSO) Solenoid	1-2
Oil-priming Pump	1-3
Genset Connections	1-3
Battery Charger Failed Switch	1-3
Battle Short Switch	1-3
Delayed Off	1-3
Emergency Stop Buttons	1-3

Event/fault Inputs	1-3
Event/fault Outputs	1-3
Exercise Switch	1-3
Fault Reset	1-3
Ground Fault Switch	1-3
Load Dump	1-4
Modbus Connections	1-4
Mode of Operation	1-4
Panel Lamp	1-4
PCCNet Devices	1-4
PC-based Service Tools	1-6
Ready to Load	1-6
Remote Start	1-6
Start Type	1-6
Switched B+ (Run) Control	1-6
System Wakeup	1-6
Certifications	1-6
2. CONTROL OPERATION	2-1
Safety Considerations	2-1
Starting and Stopping the Genset	2-1
Control Panel	2-2
Control Panel Description	2-3
Modes of Operation	2-8
Off Mode	2-8
Auto Mode	2-8
Manual Mode	2-10
Power-down Mode	2-10
PCC Power-down Mode	2-10
Operator Panel Power-down Mode	2-11
(Bidirectional) System Wakeup	2-11
Sequences of Operation	2-11
Start Sequences	2-11
Rated Speed and Voltage	2-16
Stop Sequences	2-16
Idle Requests	2-19
Stop to Idle Speed	2-19

Rated Speed to Idle Speed	2-19
Idle Speed to Stop	2-19
Idle Speed to Rated Speed	2-19
Watt Sentry	2-19
Setup Mode	2-20
3. SETUP AND CALIBRATION	3-1
Parameters	3-1
Passwords	3-1
Mode Change Password	3-1
Capture File	3-1
Override Parameters	3-1
Menu Description	3-1
Genset Data	3-2
Engine Data	3-3
Alternator Data	3-4
Faults (Faults and Warnings)	3-5
Shutdown Faults (Active Shutdowns)	3-5
Warning Faults (Active Warnings)	3-5
Fault History	3-6
Help	3-6
Setup	3-6
Display Options	3-6
Clock Setup	3-6
Modbus Setup (Setup/MODBUS)	3-8
Adjust Droop (Setup/Adjust/Droop)	3-9
Calibration Setup (Setup/Calibration)	3-9
Configurable I/O (Config I/O)	3-10
Genset Setup (Setup/Genset)	3-18
PCC Net (Setup/PCCnet)	3-25
OEM Setup	3-28
Save Restore	3-37
History-About (History/About)	3-37
Advanced Status	3-38
Genset Status (Adv Genset Status)	3-38
Controller Status (Adv Control Status)	3-41
Engine Status (Adv Engine Status)	3-43

Paralleling	3-45
Paralleling Status	3-45
Paralleling Setup	3-45
Load Demand Status	3-45
Power Status	3-45
4. PARAMETERS	4-1
Parameters That Are Not Available in the Operator Panel	4-1
5. TROUBLESHOOTING	5-1
Safety Considerations	5-1
Types of Events/Faults	5-1
Shutdown Faults	5-1
Warning Faults	5-2
Events	5-3
Fault Reset Signal	5-3
Battle Short Mode	5-3
Delayed Shutdown	5-4
Event/Fault List	5-4
Troubleshooting Procedures	5-9
How to Obtain Service	5-10



Safety Precautions

SAVE THESE INSTRUCTIONS – This manual contains important instructions that should be followed during installation and maintenance of the generator set and batteries.

Before operating the generator set (genset), read the Operator's Manual and become familiar with it and the equipment. **Safe and efficient operation can be achieved only if the equipment is properly operated and maintained.** Many accidents are caused by failure to follow fundamental rules and precautions.

The following symbols, found throughout this manual, alert you to potentially dangerous conditions to the operator, service personnel, or the equipment.

⚠ DANGER *This symbol warns of immediate hazards which will result in severe personal injury or death.*

⚠ WARNING *This symbol refers to a hazard or unsafe practice which can result in severe personal injury or death.*

⚠ CAUTION *This symbol refers to a hazard or unsafe practice which can result in personal injury or product or property damage.*

FUEL AND FUMES ARE FLAMMABLE

Fire, explosion, and personal injury or death can result from improper practices.

- DO NOT fill fuel tanks while engine is running, unless tanks are outside the engine compartment. Fuel contact with hot engine or exhaust is a potential fire hazard.
- DO NOT permit any flame, cigarette, pilot light, spark, arcing equipment, or other ignition source near the generator set or fuel tank.
- Fuel lines must be adequately secured and free of leaks. Fuel connection at the engine should be made with an approved flexible line. Do not use zinc coated or copper fuel lines with diesel fuel.
- Be sure all fuel supplies have a positive shut-off valve.

- Be sure battery area has been well-ventilated prior to servicing near it. Lead-acid batteries emit a highly explosive hydrogen gas that can be ignited by arcing, sparking, smoking, etc.

EXHAUST GASES ARE DEADLY

- Provide an adequate exhaust system to properly expel discharged gases away from enclosed or sheltered areas and areas where individuals are likely to congregate. Visually and audibly inspect the exhaust for leaks daily or per the maintenance schedule. Make sure that exhaust manifolds are secured and not warped. Do not use exhaust gases to heat a compartment.
- Be sure the unit is well ventilated.
- Engine exhaust and some of its constituents are known to the state of California to cause cancer, birth defects, and other reproductive harm.

MOVING PARTS CAN CAUSE SEVERE PERSONAL INJURY OR DEATH

- Keep your hands, clothing, and jewelry away from moving parts.
- Before starting work on the generator set, disconnect battery charger from its AC source, then disconnect starting batteries, negative (-) cable first. This will prevent accidental starting.
- Make sure that fasteners on the generator set are secure. Tighten supports and clamps, keep guards in position over fans, drive belts, etc.
- Do not wear loose clothing or jewelry in the vicinity of moving parts, or while working on electrical equipment. Loose clothing and jewelry can become caught in moving parts.
- If adjustment must be made while the unit is running, use extreme caution around hot manifolds, moving parts, etc.

DO NOT OPERATE IN FLAMMABLE AND EXPLOSIVE ENVIRONMENTS

Flammable vapor can cause an engine to over-speed and become difficult to stop, resulting in possible fire, explosion, severe personal injury

and death. Do not operate a genset where a flammable vapor environment can be created by fuel spill, leak, etc., unless the genset is equipped with an automatic safety device to block the air intake and stop the engine. The owners and operators of the genset are solely responsible for operating the genset safely. Contact your authorized Cummins Power Generation distributor for more information.

ELECTRICAL SHOCK CAN CAUSE SEVERE PERSONAL INJURY OR DEATH

- Remove electric power before removing protective shields or touching electrical equipment. Use rubber insulative mats placed on dry wood platforms over floors that are metal or concrete when around electrical equipment. Do not wear damp clothing (particularly wet shoes) or allow skin surface to be damp when handling electrical equipment. Do not wear jewelry. Jewelry can short out electrical contacts and cause shock or burning.
- Use extreme caution when working on electrical components. High voltages can cause injury or death. DO NOT tamper with interlocks.
- Follow all applicable state and local electrical codes. Have all electrical installations performed by a qualified licensed electrician. Tag and lock open switches to avoid accidental closure.
- DO NOT CONNECT GENERATOR SET DIRECTLY TO ANY BUILDING ELECTRICAL SYSTEM. Hazardous voltages can flow from the generator set into the utility line. This creates a potential for electrocution or property damage. Connect only through an approved isolation switch or an approved paralleling device.

MEDIUM VOLTAGE GENERATOR SETS (601V to 15kV)

- Medium voltage acts differently than low voltage. Special equipment and training is required to work on or around medium voltage equipment. Operation and maintenance must be done only by persons trained and qualified to work on such devices. Improper use or procedures will result in severe personal injury or death.
- Do not work on energized equipment. Unauthorized personnel must not be permitted near energized equipment. Due to the nature

of medium voltage electrical equipment, induced voltage remains even after the equipment is disconnected from the power source. Plan the time for maintenance with authorized personnel so that the equipment can be de-energized and safely grounded.

GENERAL SAFETY PRECAUTIONS

- Coolants under pressure have a higher boiling point than water. DO NOT open a radiator or heat exchanger pressure cap while the engine is running. To prevent severe scalding, let engine cool down before removing coolant pressure cap. Turn cap slowly, and do not open it fully until the pressure has been relieved.
- Used engine oils have been identified by some state or federal agencies as causing cancer or reproductive toxicity. When checking or changing engine oil, take care not to ingest, breathe the fumes, or contact used oil.
- Keep multi-class ABC fire extinguishers handy. Class A fires involve ordinary combustible materials such as wood and cloth; Class B fires, combustible and flammable liquid fuels and gaseous fuels; Class C fires, live electrical equipment. (ref. NFPA No. 10).
- Make sure that rags or combustible material are not left on or near the generator set.
- Make sure generator set is mounted in a manner to prevent combustible materials from accumulating under or near the unit.
- Remove all unnecessary grease and oil from the unit. Accumulated grease and oil can cause overheating and engine damage which present a potential fire hazard.
- Keep the generator set and the surrounding area clean and free from obstructions. Remove any debris from the set and keep the floor clean and dry.
- Do not work on this equipment when mentally or physically fatigued, or after consuming any alcohol or drug that makes the operation of equipment unsafe.
- Substances in exhaust gases have been identified by some state or federal agencies as causing cancer or reproductive toxicity. Take care not to breath or ingest or come into contact with exhaust gases.

- Do not store any flammable liquids, such as fuel, cleaners, oil, etc., near the generator set. A fire or explosion could result.
- Wear hearing protection when near an operating generator set.
- To prevent serious burns, avoid contact with

hot metal parts such as radiator system, turbo charger system and exhaust system.

KEEP THIS MANUAL NEAR THE GENSET FOR EASY REFERENCE

DISPOSE OF THIS UNIT PROPERLY



THIS PAGE LEFT INTENTIONALLY BLANK



List of Acronyms

This list is not exhaustive. For example, it does not identify units of measure or acronyms that appear only in parameters, event/fault names, or part/accessory names.

ACRONYM	DESCRIPTION
AC	Alternating Current
AMP	AMP, Inc., part of Tyco Electronics
ASTM	American Society for Testing and Materials (ASTM International)
ATS	Automatic Transfer Switch
AVR	Automatic Voltage Regulator
AWG	American Wire Gauge
CAN	Controlled Area Network
CE	Conformité Européenne
CGT	Cummins Generator Technologies
CT	Current Transformer
DC	Direct Current
ECM	Engine Control Module
EMI	Electromagnetic Interference
EN	European Standard
EPS	Engine Protection System
E-Stop	Emergency Stop
FAE	Full Authority Electronic
FMI	Failure Mode Identifier
FSO	Fuel Shutoff
genset	Generator Set
GND	Ground
HMI	Human-machine Interface
IC	Integrated Circuit
ISO	International Organization for Standardization
LCD	Liquid Crystal Display
LCL	Low Coolant Level
LCT	Low Coolant Temperature
LED	Light-emitting Diode

Mil Std	Military Standard
NC	Not Connected Normally Closed
NFPA	National Fire Protection Agency
NO	Normally Open
NWF	Network Failure
OEM	Original Equipment Manufacturer
OOR	Out of Range
OORH ORH	Out of Range High
OORL ORL	Out of Range Low
PB	Push Button
PC	Personal Computer
PCC	PowerCommand® Controller
PGI	Power Generation Interface
PI	Proportional/Integral
PID	Proportional/Integral/Derivative
PLC	Programmable Logic Controller
PMG	Permanent Magnet Generator
PT	Potential Transformer
PTC	Power Transfer Control
PWM	Pulse-width Modulation
RFI	Radio Frequency Interference
RH	Relative Humidity
RMS	Root Mean Square
RTU	Remote Terminal Unit
SAE	Society of Automotive Engineers
SPN	Suspect Parameter Number
SW_B+	Switched B+
UL	Underwriters Laboratories

AmpSentry and InPower are trademarks of Cummins Inc. PowerCommand is a registered trademark of Cummins Inc.

THIS PAGE LEFT INTENTIONALLY BLANK



Glossary

TERM	DEFINITION
Accessory Part	A part comes standard with the product. An accessory is optional and provides additional interfaces or functionality.
Active Inactive	<p>General terms to describe the states for inputs, signals, or outputs that have only two states (like true/false or 1/0). For example, a low coolant level switch is either on (active) or off (inactive). The Ready to Load output is either on (active) or off (inactive). Usually, the expected state is inactive.</p> <p>For events/faults, this term describes the time the PCC generates the event/fault through the time the event/fault is cleared.</p>
Active-high Active-low	Some inputs and outputs use voltage differential to distinguish between active and inactive. If an input or output is active-high, a high voltage differential means the input or output is active, and a low voltage differential means the input or output is inactive. If an input or output is active-low, a low voltage differential means the input or output is active, and a high voltage differential means the input or output is inactive.
Connection	A connection between two devices. A connection might be as simple as one pin-to-pin connection, or it might require several pins as well as additional components such as relays, fuses, etc. This term also includes some settings that refer to the physical (for example, normally-closed vs. normally-open) or electrical (for example, active-high vs. active-low) characteristics of the connection.
Connector	<p>This term has no meaning if you do not have access to the PCC base board or the back panel of the Operator Panel.</p> <p>One or more pins that are in the same housing. Many times, the pins are related by function (for example, pins that are connected to the engine) or by electrical characteristics (for example, relay outputs).</p> <p>This term also refers to the end of a wire or harness that is plugged into the housing.</p>
Event Fault	<p>Used to notify the operator or external devices whether or not certain conditions are true. Each event or fault has two sets of conditions. When the first set of conditions becomes true, the event or fault becomes active. This might turn on or turn off a light or LED, display a warning on the PCC, shut down the genset, or so on. When the second set of conditions becomes true, the event or fault becomes inactive and can be cleared.</p> <p>The PCC generates a fault when the conditions indicate a more serious problem; the PCC generates an event only for information purposes.</p>
Genset	Generator set
Low-side driver	When this output is active, it provides a path to ground. When this output is inactive, it blocks the path to ground.
Mode Mode of operation	A term to describe certain states that affect the PCC's behavior. The PCC is either in a particular mode or not in a particular mode, and the PCC's behavior changes accordingly. Sometimes, the PCC is always in one mode out of a set of two or more modes. For example, the PCC is always in one of the modes of operation: Off mode, Auto mode, or Manual mode.
Mounting	The physical placement and installation of the PCC or the Operator Panel.
Normally-closed Normally-open	Some inputs and outputs use open circuits and short circuits to distinguish between active and inactive. If an input or output is normally-closed, an open circuit means the input or output is active, and a short circuit means the input or output is inactive. If an input or output is normally-open, a short circuit means the input or output is active, and an open circuit means the input or output is inactive.
Parameter	<p>Refers to monitored values or settings in the PCC or the Operator Panel that can be looked at and, in some cases, adjusted in the Operator Panel or InPower. Some parameters are protected by passwords.</p> <p>In this manual, <i>italics</i> are used to identify a specific parameter by name.</p>

TERM	DEFINITION
Pin	<p>A specific point on the PCC or the Operator Panel to which it is acceptable to connect a specific point on an external device. For example, a B+ pin might be connected to the positive terminal on the battery. It takes more than one pin to connect an external device to the PCC. For example, it takes B+ and Ground to connect the battery to the PCC.</p> <p>Depending on the access you have to the controller, you might see a specific pin on the PCC base board, the terminal at the end of a harness, a wire that runs between the PCC and the external device, or nothing at all.</p>
Sensor	<p>Refers to a device that measures something and reports one of many (or unlimited) values. For example, a coolant level sensor reports the current level of coolant.</p>
Sequence of operation	<p>A term used to describe the steps the PCC follows when it starts the genset or when it stops the genset.</p>
Signal	<p>A term used for convenience to talk about two or more connections as a single input. Usually, all of these connections have the same effect on the PCC's behavior, and it does not matter which connection is active.</p> <p>For example, the term "remote start signal" is used frequently. In Auto mode, the PCC starts the genset when the remote start signal is active. The remote start signal may come from any of several connections: a switch connected to the remote start pin, the Operator Panel, a PLC (programmable logic controller) connected on Modbus, InPower, etc. It is not important between these connections when explaining the way the remote start signal affects the PCC's decisions to start and stop the genset. It is only important whether or not any of them are active.</p>
Switch	<p>Refers to a device that measures something and reports one of two states, active or inactive, about something. For example, a low coolant level switch is active when the coolant level is too low, but the low coolant level switch does not report what the coolant level really is.</p> <p>In some cases, this may refer to a physical switch (similar to a light switch) instead.</p>
Trim	<p>Refers to the subset of parameters that can be adjusted, as opposed to parameters that can only be monitored.</p>



1. System Overview

Read **Safety Precautions**, and carefully observe all of the instructions and precautions in this manual. Keep this manual with the other genset and/or controller manuals.

ABOUT THIS MANUAL

You should have a basic understanding of generators and power generation before you read this manual.

This is the Operator Manual for the PowerCommand 2.2. It is not the Operator Manual for the generator set (“genset”) or any accessories.

DESCRIPTION

The PowerCommand 2.2 is suitable for non-parallel generator sets (“gensets”) in standby or prime-power applications.

The PowerCommand 2.2 consists of these parts.

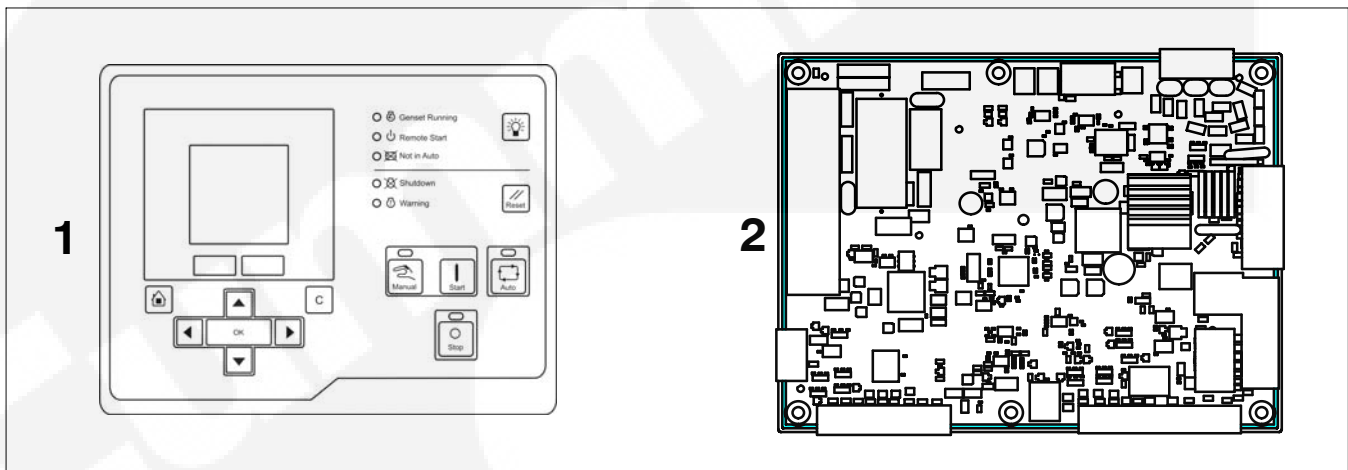

FIGURE 1-1. POWERCOMMAND 2.2

TABLE 1-1. POWERCOMMAND 2.2

1: HMI 220 (“OPERATOR PANEL”)
2: PCC 2300 CONTROLLER (“PCC”)

The Operator Panel is one way to monitor, manage, and control the genset. An operator can use the Operator Panel to do these things.

- Look at the status of the genset.
- Adjust settings that affect genset behavior.
- Start and stop the genset.

Note: In addition to the Operator Panel, other devices can monitor, manage, and control the genset too. Such devices might be as simple as a switch or a push button or as sophisticated as other controllers or computers. This manual introduces the ways the PCC can interact with other devices, but this manual cannot identify all of the devices that might be used in every application.

The PCC is a microprocessor-based controller that has these abilities.

- Control the genset to maintain a specified genset voltage and genset frequency
- Warn the operator when unsafe conditions are occurring
- Shut down the genset to prevent damage
- Provide a way for other devices (such as the Operator Panel) to monitor, manage, and control the genset

Note: The PCC should be installed where it can be accessed only by authorized service representatives. Unauthorized personnel, including an operator, should not have access to it.

ALTERNATOR CONNECTIONS

This section introduces the connections between the PCC and the alternator.

Main Alternator Output

The PCC is connected to the main alternator output to measure genset voltage, genset current, and genset frequency.

If the PCC uses self-excitation to regulate the genset voltage, the PCC is also connected to the main alternator output to drive the field windings in the exciter.

The PCC is connected to current transformers (CTs) to reduce the genset current before it is measured.

The PCC may be connected to potential transformers (PTs) to reduce the genset voltage before it is measured.

Permanent Magnet Generator (PMG)

If the PCC uses a permanent magnet generator (PMG) to regulate the genset voltage, the PCC is connected to the PMG to drive the field windings in the exciter.

Exciter (Field Windings)

If the PCC regulates the genset voltage, the PCC is connected to the exciter to control the magnetic field in the exciter and, in turn, the genset voltage. The input power for the field windings comes from the PMG or the main alternator output.

See **Sequences of Operation** (page 2-11) for more information about the behavior of this output.

Battery-charging Alternator

The PCC may be connected to the battery-charging alternator to make sure the battery-charging alternator is recharging the battery properly.

High Alternator Temperature Switch

The PCC may be connected to a switch that is active when the alternator temperature is too high.

ENGINE CONNECTIONS

This section introduces the connections between the PCC and the engine.

Battery Connections

The battery provides power for the PCC and the Operator Panel, and the PCC monitors the battery voltage.

Starter

The PCC may be connected to the starter control relay in order to control the starter.

See **Sequences of Operation** (page 2-11) for more information about the behavior of this output.

Engine Control Module (ECM)

The PCC is connected to the engine control module (ECM) to monitor, control, and protect the engine.

See **Sequences of Operation** (page 2-11) for more information about the behavior of this connection.

Low Coolant Temperature (LCT) Switch

The PCC may be connected to a switch that is active when the coolant temperature is too low.

Low Coolant Level (LCL) Switch

The PCC may be connected to a switch that is active when the coolant level is too low.

Low Coolant Level (LCL) Switch #2

The PCC may be connected to a switch that is active when the coolant level is too low.

Low Fuel Level Switch

The PCC may be connected to a switch that is active when the fuel level is too low.

Low Fuel in Day Tank Switch

The PCC may be connected to a switch that is active when the fuel level in a day tank is too low.

Rupture Basin Switch

The PCC may be connected to a switch that is active when there is fuel in the rupture basin.

Fuel Shutoff (FSO) Solenoid

The PCC may be connected to the fuel shutoff (FSO) solenoid to control the fuel supply for the engine.

See **Sequences of Operation** (page 2-11) for more information about the behavior of this output.

Oil-priming Pump

The PCC may be connected to the oil-priming pump to prelube the engine. This reduces wear and damage to moving parts in the engine after long periods of inactivity.

See **Sequences of Operation** (page 2-11) for more information about the behavior of this output.

GENSET CONNECTIONS

This section introduces the connections between the PCC and other parts of the genset.

Some of these connections are flexible and might be made to many types of devices, including the engine and the alternator.

Typical devices are identified in some connections, but other types may also be possible in these connections.

Battery Charger Failed Switch

The PCC may be connected to a battery charger to make sure the battery charger is working properly.

Battle Short Switch

The PCC may be connected to a device that puts the PCC in Battle Short mode (page 5-3).

Delayed Off

The PCC may notify a device while the genset is running and for *Delayed Off FSO Relay Time* after the genset stop running.

Emergency Stop Buttons

The PCC may be connected to one or two buttons that shut down the genset immediately when pressed.

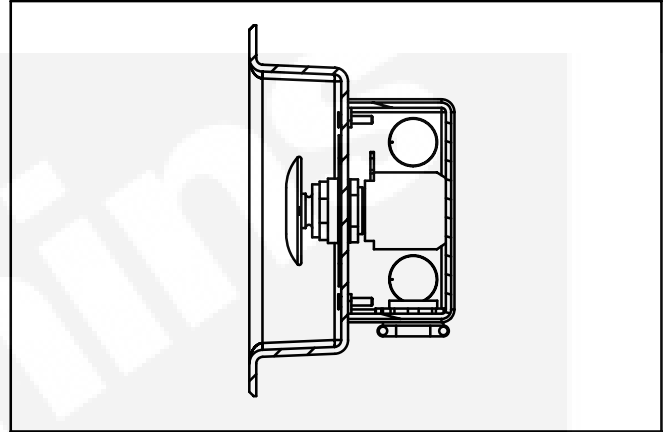

FIGURE 1-2. EMERGENCY STOP BUTTON (EXAMPLE)

Event/fault Inputs

The PCC may be connected to a device that generates an event/fault.

The PCC has four configurable inputs (page 3-10) that can support this function.

Event/fault Outputs

The PCC can notify a device when a specified event/fault code is active. For example, the PCC might turn on a coolant heater if the coolant temperature is too low.

The PCC has nine configurable outputs (page 3-12) that can support this function.

Exercise Switch

The PCC may be connected to a device that can generate an exercise signal (page 2-8).

Fault Reset

The PCC may be connected to a device that can generate a fault reset signal (page 5-3).

Typically, the device is the Operator Panel.

Ground Fault Switch

The PCC may be connected to a ground fault relay that is active when there is a short to ground on the load-side of the genset.

Load Dump

The PCC may notify a device when warning fault 1464 (Load Dump Fault) (page 3-20) is active.

Modbus Connections

The PCC may be connected to a device that monitors, manages, and controls the genset.

Note: Modbus is a serial communications protocol that is commonly used in industry.

Mode of Operation

The PCC is connected to a device that controls the mode of operation (page 2-8) the PCC is in.

Typically, the device is the Operator Panel or a key-switch.

Panel Lamp

The PCC may be connected to a light that is controlled by the Lamp Test button (page 2-6). Press the Lamp Test button for three seconds to turn the light on and off.

PCCNet Devices

The PCC may be connected to one or more PCCNet devices, such as the Operator Panel, that let operators monitor, manage, and control the genset.

Note: PCCNet is Cummins Power Generation's proprietary standard for RS-485 networks. Each PCCNet network can be up to 4000 feet long and contain up to twenty PCCNet devices.

In addition to the PCCNet connection, PCCNet devices may use the PCC's Fault Reset (page 1-3), Mode of Operation (page 1-4), System Wakeup (page 1-6), or other connections.

The PCC supports these PCCNet devices.

HMI 112

The HMI 112 is the Bargraph Meter. It provides visible indication of genset voltage, genset current, and genset power.

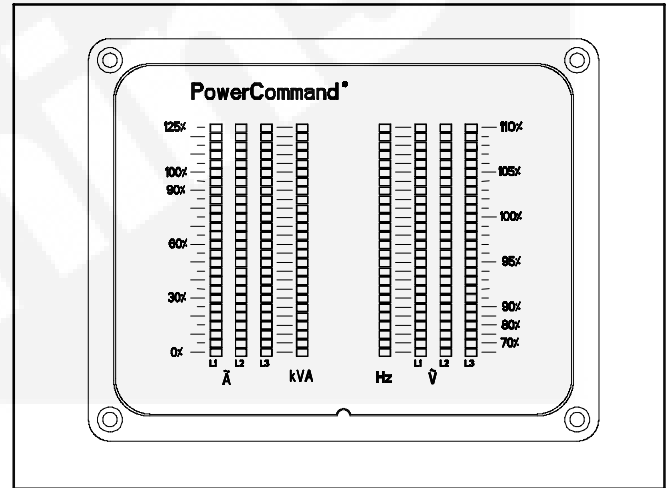
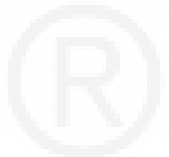

FIGURE 1-3. HMI 112 (0300-6050-02)

The PCC supports an unlimited number of HMI 112 on each PCCNet network, but each PCCNet network is limited to twenty PCCNet devices.

HMI 113

The HMI 113 is the Universal Annunciator Module. It provides visible and audible indication of genset



alarms and status based on discrete relay or network inputs.

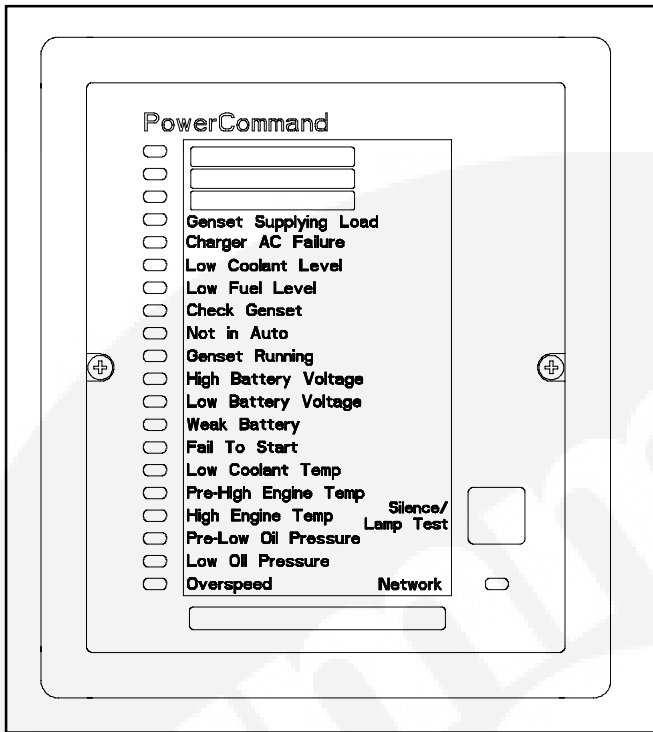

FIGURE 1-4. HMI 113 (0300-5929-01)

The HMI 113 supports different overlays.

The PCC supports up to four HMI 113 on each PCCNet network.

HMI 114

The HMI 114 is the Bargraph Meter. It provides visible indication of genset voltage, genset current, and genset power.

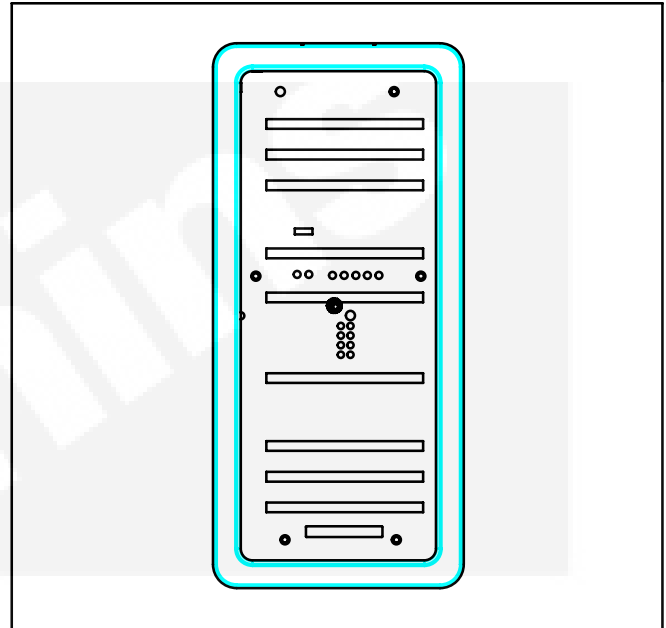

FIGURE 1-5. HMI 114

The PCC supports an unlimited number of HMI 114 on each PCCNet network, but each PCCNet network is limited to twenty PCCNet devices.

HMI 220

The HMI 220 is the Operator Panel for the PCC and the genset.

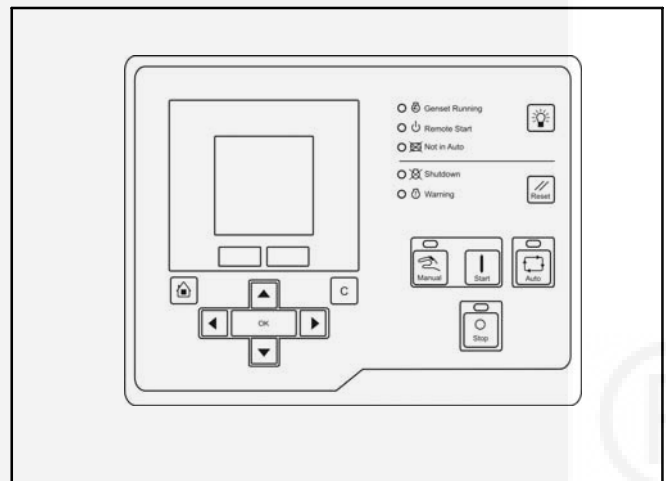

FIGURE 1-6. HMI 220 (0300-6314-01)

The PCC supports up to two HMI 220 on each PCCNet network.

PC-based Service Tools

The PCC or the Operator Panel may be connected to a PC-based service tool, such as InPower, to monitor, manage, and control the genset.

Note: See the PC-based service tool documentation for more information.

The PC-based service tool harness (Figure 1-7) is used to connect the PCC or the Operator Panel to a PC-based service tool.

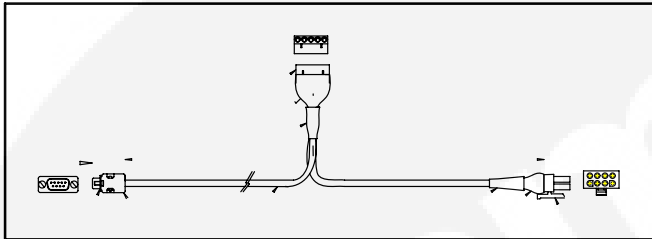

FIGURE 1-7. PC-BASED SERVICE TOOL HARNESS

Ready to Load

The PCC may notify a device when event 1465 (Ready to Load) (page 3-30) is active.

Typically, the device is a programmable logic controller (PLC).

Remote Start

The PCC may be connected to a device that can generate a remote start signal (page 2-9).

Typically, the device is a transfer switch.

Start Type

The PCC may be connected to a device that can generate a start type signal (page 2-9).

This connection may be hard-wired in some gensets.

Switched B+ (Run) Control

The PCC may provide power to a device while the genset is running. The PCC does not provide power when the genset is not running.

Note: This connection is also referred to as a run relay.

System Wakeup

The PCC and the Operator Panel may be connected to other devices with which the PCC and the Operator Panel enter and leave power-down mode (page 2-10) together.

These connections may be hard-wired in some gensets.

CERTIFICATIONS

The PCC meets or exceeds the requirements of the following codes and standards.

- UL 508 Recognized marked
- UL NRGU
AmpSentry protective relay certified
- CSA marked
- C282 compliant
- 22.2 compliant
- NFPA 99 compliant
- NFPA 110 compliant
Requires HMI 113
- MS 202C, Method 101 compliant
- IEEE C62.41 compliant
- IEEE C37.90 compliant
- BS ISO 8528-4:2005
- BS EN 50081-1:1992
- BS EN 61000-6-2:2001
- BS EN 61000-6-3:2001
- BS EN 61000-6-4:2001
- CE Marking: The control system is suitable for use on generator sets to be CE-marked.

The Operator Panel is UL508 listed.

2. Control Operation

In this section, *italics* are used to identify a specific parameter by name.

Otherwise, use the buttons on the control panel (Figure 2-1).

SAFETY CONSIDERATIONS

AC power is present when the genset is running. Do not open the generator output box while the genset is running.

⚠️WARNING *Contacting high-voltage components can cause electrocution, resulting in severe personal injury or death. Do not open the generator output box while the set is running. Read and observe all WARNINGS and CAUTIONS in your genset manuals.*

The PCC cabinet must be opened only by technically qualified personnel.

⚠️WARNING *The PCC cabinet must be opened only by qualified personnel. High-level voltages (up to 600 VAC) are present in the PCC cabinet. These voltages can cause electrical shock, resulting in personal injury or death.*

⚠️CAUTION *Even with the power removed, improper handling of components can cause electrostatic discharge and damage to circuit components.*

Read **Safety Precautions**, and carefully observe all of the instructions and precautions in this manual.

STARTING AND STOPPING THE GENSET

If the genset provides a switch or keyswitch, use the switch or keyswitch to start and stop the genset.

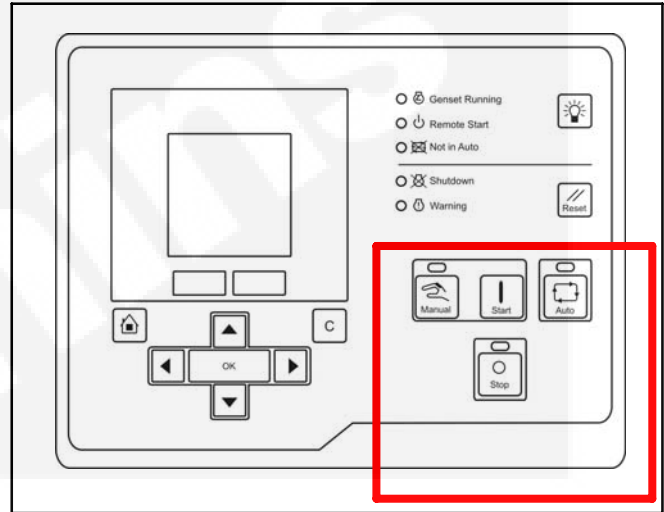

FIGURE 2-1. CONTROL PANEL BUTTONS

The buttons are related to modes of operation (page 2-8).

TABLE 2-1. CONTROL PANEL BUTTONS

BUTTON(S)	DESCRIPTION
Manual Start	Start the genset immediately. You have to push the Start button less than ten seconds after you push the Manual button.
Auto	The genset starts and stops when it is told by other devices (such as a transfer switch) or when it is scheduled to do so.
Stop	Stop the genset. If the genset was previously running in Manual mode, the genset might cool down for a while before it stops, depending on various parameters. If you want to stop the genset immediately, press the Stop button a second time. If the genset was previously running in Auto mode, the genset stops immediately.

⚠️WARNING *The genset might not start or stop immediately. Do not attempt to service the genset if it does not appear to respond immediately. Accidental starting of the genset during trouble-*

shooting can cause severe personal injury or death.

When the genset starts and stops, it follows a series of steps, called a sequence of operation (page 2-11), that are intended to maximize the life of the genset. The genset might not start or stop immediately.

If the Operator Panel tells you to enter the mode change password, enter 121.

CONTROL PANEL

The control panel (Figure 2-2) is the front panel of the Operator Panel.

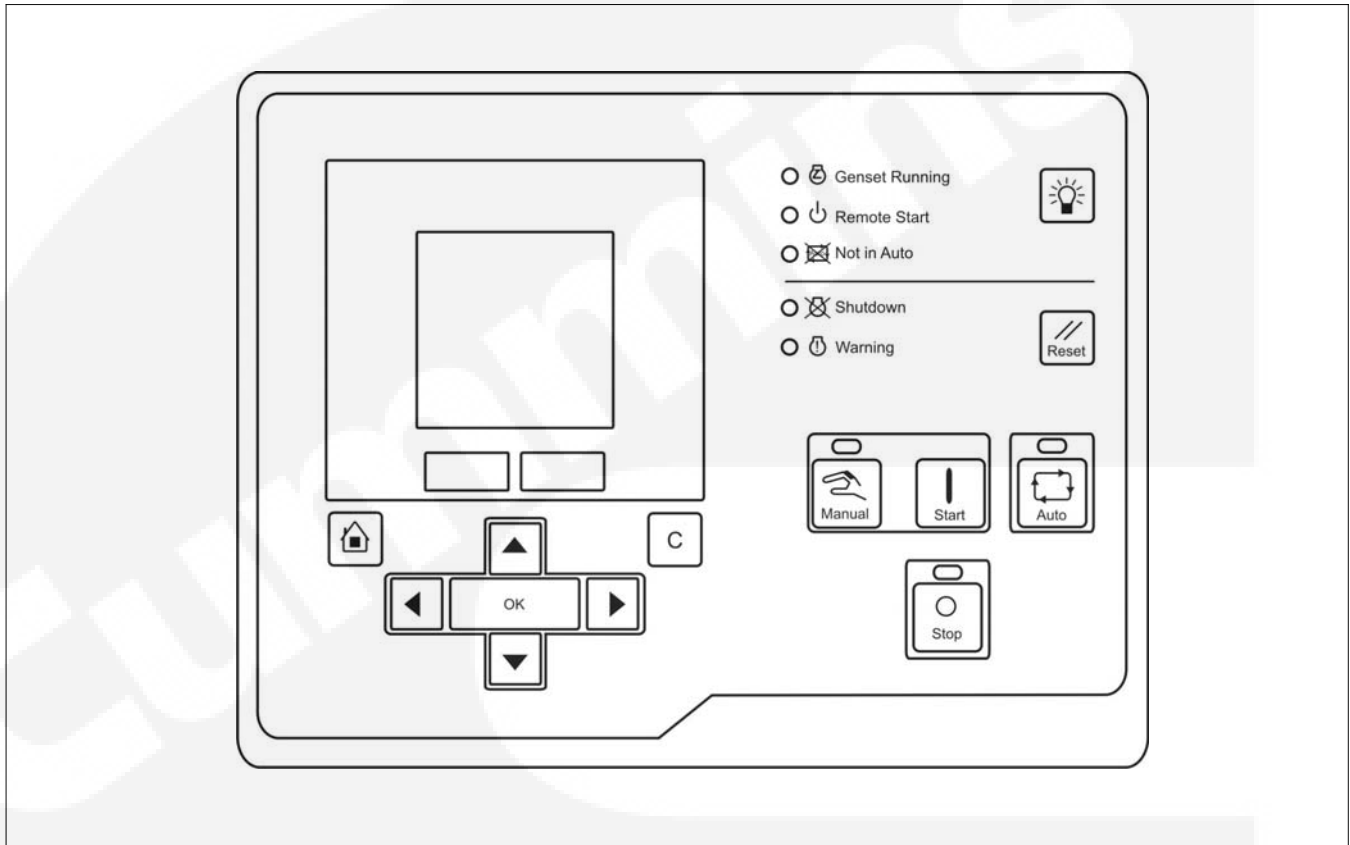

FIGURE 2-2. CONTROL PANEL (POWERCOMMAND 2.2, HMI 220)

Control Panel Description

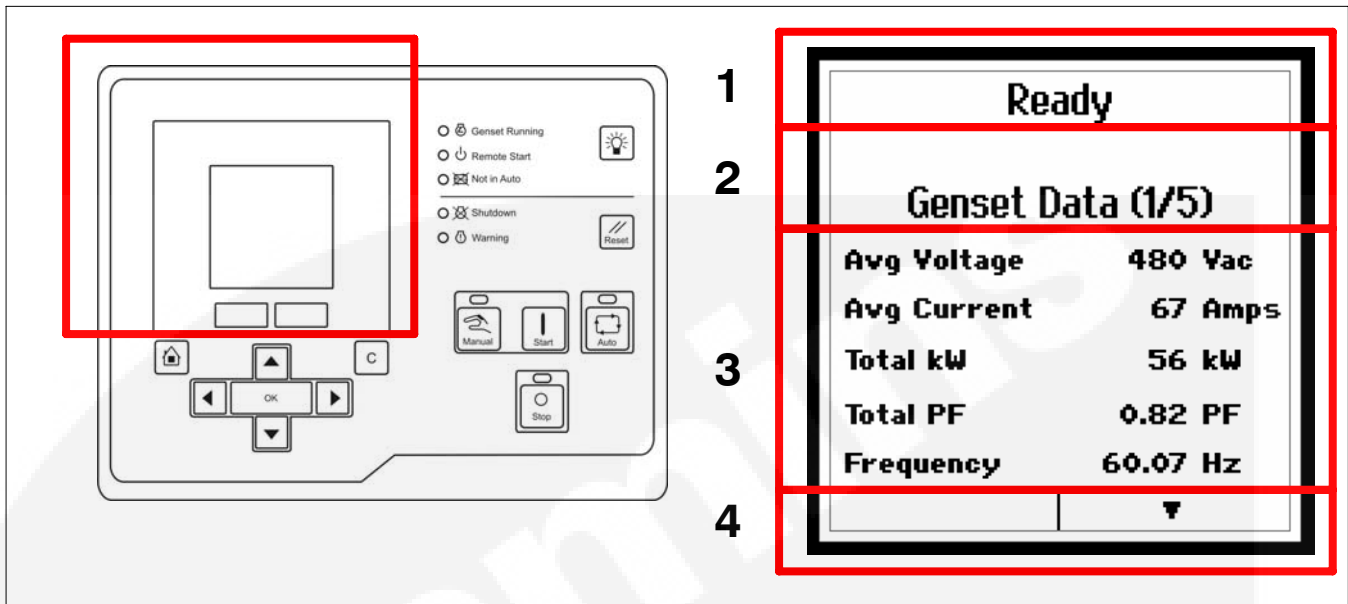

FIGURE 2-3. GRAPHICAL DISPLAY (AND TYPICAL SCREENSHOT)

TABLE 2-2. GRAPHICAL DISPLAY (AND TYPICAL SCREENSHOT)

LABEL	DESCRIPTION
1	PCC status
2	Active fault or screen name
3	Interactive screen or menu
4	Functions for selection buttons

Use the graphical display to look at event/fault information, status, screens, and parameters.

Use the Display Options screen (page 3-6) to adjust display settings, such as contrast, language, or unit of measure.

Section 1 displays the status of the PCC.

TABLE 2-3. PCC STATUS IN THE GRAPHICAL DISPLAY

STATUS	DESCRIPTION
Ready	This is the default state. The PCC is ready to start the genset, or the PCC has started one of the start sequences (page 2-11) but has not started the engine yet.
Starting	The PCC is starting the engine in one of the start sequences. The genset has not reached idle speed (if applicable) or rated speed and voltage, and the PCC is not raising the engine speed to idle speed or rated speed.
Idle Warmup	The PCC is raising the engine speed to idle speed, or the engine is running at idle speed in one of the start sequences.
Rated Freq and Voltage	The PCC is raising the engine speed to rated speed; the genset is running at rated speed and voltage; or the PCC has started one of the stop sequences (page 2-16) but has not started reducing the engine speed yet.
Idle Cooldown	The PCC is reducing the engine speed to idle speed, or the engine is running at idle speed in one of the stop sequences.
Stopping	The PCC is stopping the engine.
Emergency Stop	There is an active shutdown fault (page 5-1).
Setup Mode	The PCC is in Setup mode (page 2-20).
Wait to Powerdown	The PCC is ready to enter Power-down mode (page 2-10), but another device is sending a System Wakeup signal.
Demo Mode	The PCC is running a demonstration. Every screen is available in the demonstration, and any changes you make in the demonstration have no effect on the PCC. You have to turn off the Operator Panel to end the demonstration.

Section 2 displays information about the last active shutdown fault. If there are no active shutdown faults, it displays the last active warning fault. If there are no active faults, the Operator Panel displays the screen name.

If there is an active fault, the Operator Panel displays this information about it.

- Fault type (Table 2-4)
- Fault code number
- Name of the controller that detected the fault (for example, many engine faults are detected

by the ECM). This is blank if the PCC detected the fault.

- Fault name

If you press the Reset button (page 2-6), the Operator Panel stops displaying active warning faults, even if the condition(s) that caused the fault(s) has not been corrected. The Warning LED (page 2-6) remains on, however.

The Operator Panel always displays any active shutdown faults, even if you press the Reset button.

TABLE 2-4. FAULT TYPE IN THE GRAPHICAL DISPLAY

TYPE	DESCRIPTION
Warning	This is a warning fault (page 5-2).
Derate	This is a derate event (page 5-3).
Shutdown	This is a shutdown fault (page 5-1) that initiated a Shutdown Without Cooldown sequence (page 2-18).

Section 3 is interactive. You can look at operating values for the genset, navigate through screens, and adjust parameters.

The default screen is the Genset Data screen (page 3-2). See Section 3 for more information about these screens.

Table 2-5 explains how the Operator Panel displays when the value of a specific parameter is missing, unexpected, or outside the range allowed for the parameter.

TABLE 2-5. UNAVAILABLE PARAMETERS IN THE OPERATOR PANEL

OPERATOR PANEL	DESCRIPTION
NWF	There is a PCCNet network failure or a CAN (ECM) failure.
OORL	The value is less than the lowest allowed value for this parameter.

OORH	This value is greater than the highest allowed value for this parameter.
---	The value is not applicable.

Section 4 identifies additional functions that are available by pressing one of the selection buttons beneath the graphical display. If the box above the selection button is empty, that particular selection button has no function at this time.

For example, if the graphical display is not big enough to display the screen at one time, press the appropriate selection button to look at the previous or next page of information in that screen.



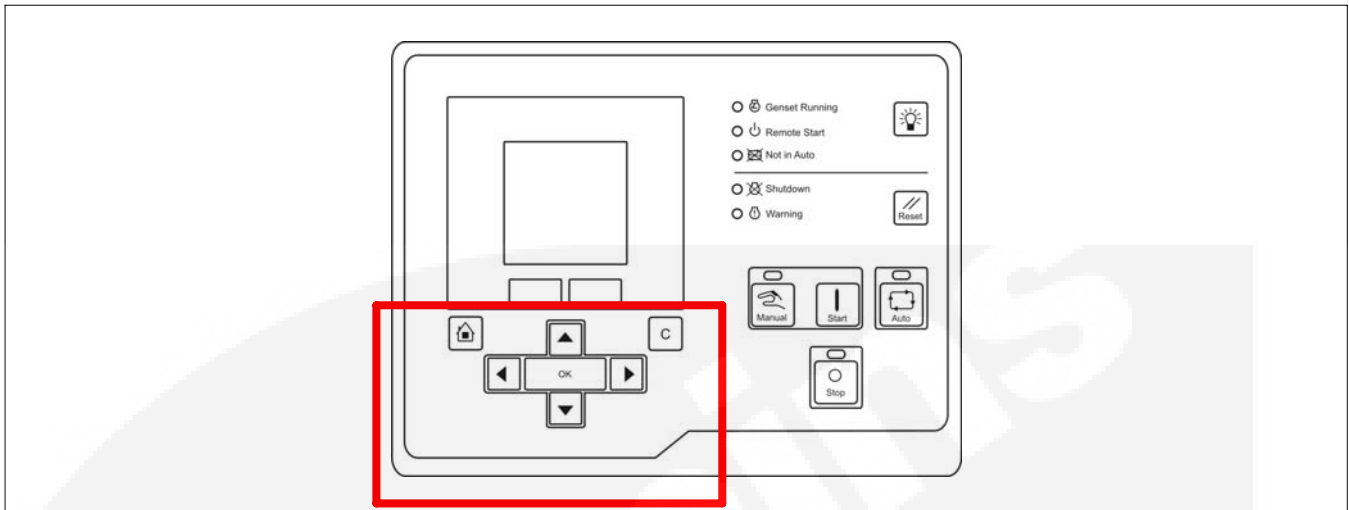

FIGURE 2-4. MENU NAVIGATION BUTTONS



The  button is called the Home button.

TABLE 2-6. MENU NAVIGATION BUTTONS

LED/BUTTON	DESCRIPTION
Home	Press this to return to the main menu (page 3-1). If the PCCNet connection (page 1-4) between the PCC and the Operator Panel is not active, press this for three seconds to start a demonstration of the Operator Panel. Every screen is available in the demonstration, and any changes you make in the demonstration have no effect on the PCC. You have to remove power from the Operator Panel to end the demonstration.
C	Press this to return to the previous menu. Note: If you have not pressed OK, the control panel does not save the changes when you press the C button.
Up, Down, Left, Right	Press these to change the selection in the graphical display.
OK	Press this to select the item that is currently highlighted in the graphical display. If the selected item is a menu item, this opens a sub-menu or screen. If the selected item is a parameter, this lets you adjust the parameter (if possible) or prompts you for a password. If the selected item is a value you have just adjusted, this saves the change in temporary memory. If the selected item is an action, the Operator Panel runs the action or prompts you for a password.

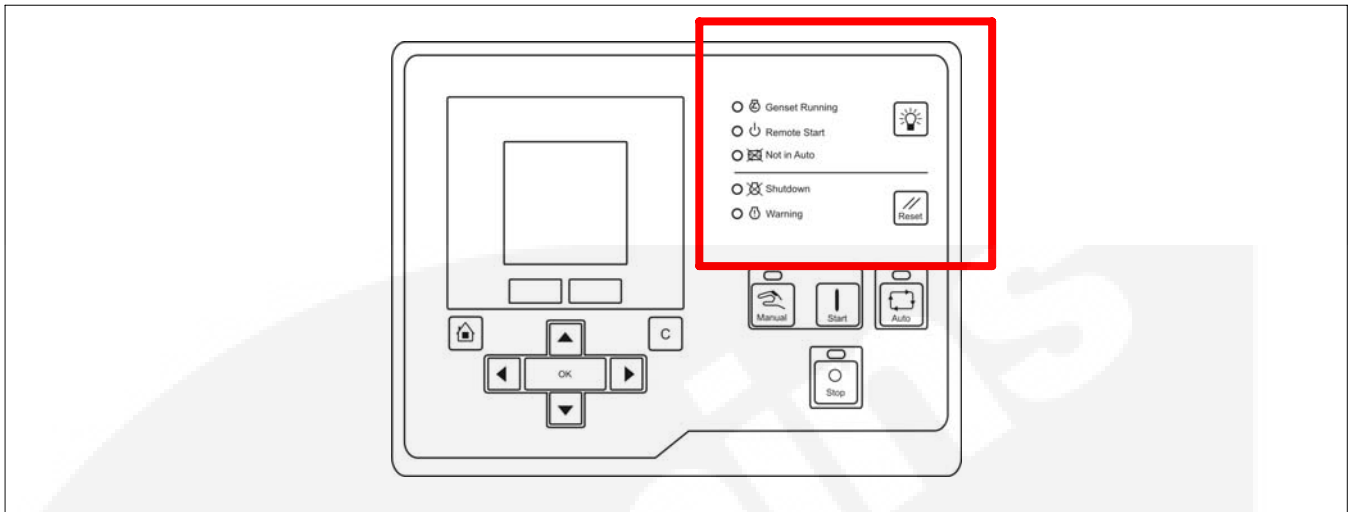

FIGURE 2-5. LED INDICATORS AND BUTTONS



The  button is called the Lamp Test button.

If the PCCNet connection (page 1-4) between the PCC and the Operator Panel is not active, the LEDs in Table 2-7 remain off (except during Lamp Test).

TABLE 2-7. LED INDICATORS AND BUTTONS

LED/BUTTON	DESCRIPTION
Genset Running	This green LED is lit when event 1465 (Ready To Load) is active. The genset is running at or near rated speed and voltage (page 2-16). This is not lit while the genset is warming up or cooling down.
Remote Start	This green LED is lit when the remote start signal (page 2-9) is active. This signal has no effect unless the PCC is in Auto mode (page 2-8).
Not in Auto	This red LED blinks when event 1463 (Not in Auto) is active. The PCC is not in Auto mode (page 2-8).
Shutdown	This red LED is lit when event 1541 (Common Shutdown) is active. There is an active shutdown fault (page 5-1).
Warning	This amber LED is lit when event 1540 (Common Warning) is active. There is an active warning fault (page 5-2).
Lamp Test	Press this to test the LEDs. All of the LEDs should turn on for five seconds. Press and hold this for three seconds to turn on or turn off (to toggle) a panel lamp.
Reset	Press this to generate a fault reset signal (page 5-3). The Operator Panel's Fault Reset is active as long as this button is pressed, and the Operator Panel sends the fault reset through the PCCNet connection between the PCC and the Operator Panel. If the condition(s) that caused an existing shutdown fault still exists, the PCC generates the fault again. If the condition(s) that caused an existing warning fault still exists, the PCC generates the fault again, but the Operator Panel stops displaying it in the graphical display.

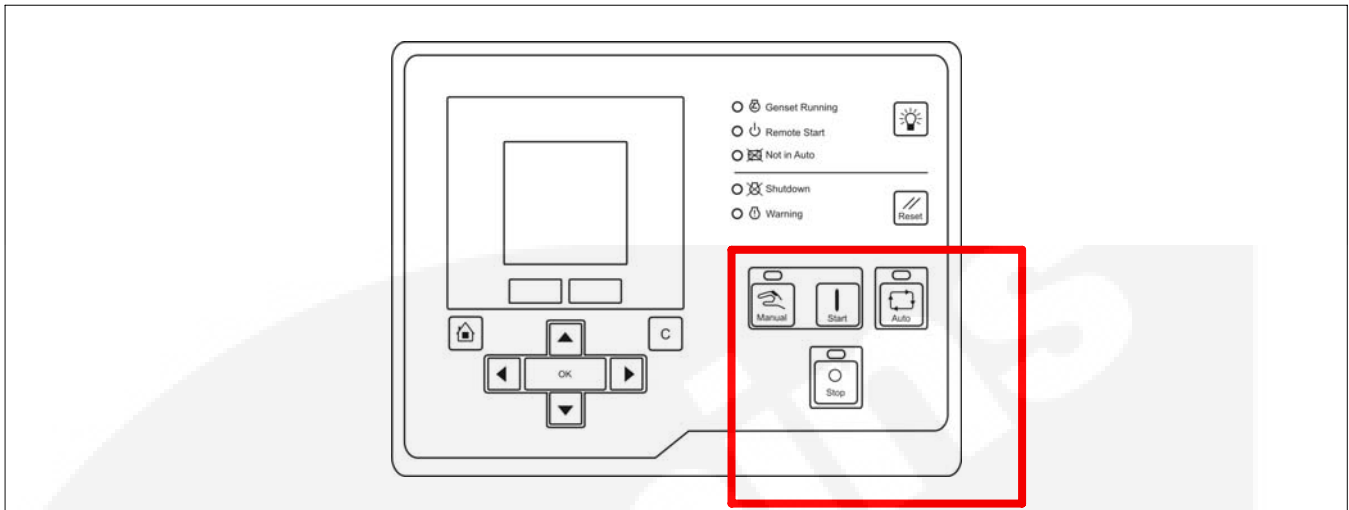

FIGURE 2-6. BUTTONS

If Mode Change is Enabled in the Display Options screen (page 3-6), you have to enter the password 121 when you use these buttons to change the mode of operation (page 2-8).

If there is a keyswitch, the LEDs in Table 2-8 still work properly.

TABLE 2-8. BUTTONS

LED/BUTTON	DESCRIPTION
Manual	<p>Press this to put the PCC in Manual mode (page 2-10). If you do not press the Start button in ten seconds, the Operator Panel automatically puts the PCC in Off mode (page 2-8).</p> <p>The green LED above this button is lit when the PCC is in Manual mode.</p> <p>If the LED above this button is blinking, there is a problem with the Mode of Operation connection. Please contact your local distributor.</p>
Start	<p>In Manual mode, press this to initiate a Manual Start sequence (page 2-14). In other modes, this button has no effect.</p>
Auto	<p>Press this to put the PCC in Auto mode (page 2-8).</p> <p>The green LED above this button is lit when the PCC is in Auto mode.</p> <p>If the LED above this button is blinking, there is a problem with the Mode of Operation connection. Please contact your local distributor.</p>
Stop	<p>In Manual mode, press this one time to initiate a Manual Stop sequence (page 2-17) if the genset is running. The green LED above this button blinks while the PCC shuts down the genset. When the Manual Stop sequence is done, the Operator Panel puts the PCC in Off mode (page 2-8).</p> <p>Note: While the Manual Stop sequence is running, press this button a second time to shut down the genset immediately. The PCC initiates a Shutdown Without Cooldown sequence (page 2-18).</p> <p>If the genset is running in Auto mode, press this to initiate a Shutdown Without Cooldown sequence.</p> <p>If the genset is not running, press this to put the PCC in Off mode.</p> <p>If the genset is running and the PCCNet connection (page 1-4) is not active, press this to initiate a Shutdown Without Cooldown sequence.</p> <p>The LED above this button is lit when the PCC is in Off mode.</p> <p>If the LED above this button is blinking when the PCC is not shutting down the genset in Manual mode, there is a problem with the Mode of Operation connection. Please contact your local distributor.</p>

MODES OF OPERATION

The mode of operation determines the ways the genset can be started and stopped. The PCC runs in one of these modes at any given time.

The mode of operation is controlled by the Mode of Operation connection. Typically, the device to which the PCC is connected is the Operator Panel or a keyswitch.

In applications where the Operator Panel controls the mode of operation, Table 2-8 explains how to change the mode of operation.

In applications where a keyswitch controls the mode of operation, please contact your local distributor to understand the purpose of each position in the keyswitch.

Off Mode

In this mode, the PCC does not allow the genset to start. You have to change the mode of operation if you want to start the genset.

If the genset is running when the PCC enters this mode, the PCC initiates a Shutdown Without Cooling sequence (page 2-18). If the genset was running at 10% or more of its rated load, the PCC generates warning fault 611 (Engine Hot Shut Down).

In applications where the Operator Panel controls the mode of operation, you can put the PCC in Off mode one of these ways.

- If the genset is running in Manual mode, press the Stop button, and wait for the genset to stop; or press the Stop button twice.
- If the genset is not running or in any other mode, press the Stop button once.
- Do not push the Start button after pressing the Manual button.

Auto Mode

In this mode, the genset is controlled by the exercise signal (page 2-8) and the remote start signal (page 2-9).

⚠WARNING *In Auto mode, the genset can start at any time. NEVER service the genset in Auto mode. Accidental starting of the genset during troubleshooting can cause severe personal in-*

jury or death. Disable the genset before troubleshooting.

If the genset is running when the PCC enters this mode, the PCC keeps running the genset if the remote start signal is active. Otherwise, the PCC initiates a Shutdown with Cooldown sequence (page 2-16).

When the exercise signal or the remote start signal becomes active, the PCC initiates the appropriate start sequence (page 2-11) to start the genset. The PCC continues to run as long as either signal is active.

When neither signal is active anymore, the PCC initiates a Shutdown with Cooldown sequence (page 2-16).

In applications where the Operator Panel controls the mode of operation, press the Auto button to put the PCC in Auto mode.

Exercise Signal

This signal has no effect unless these conditions are met.

- The PCC is in Auto mode (page 2-8).
- There are no active shutdown faults (page 5-1).

If the genset is running, this signal has no effect until the remote start signal (page 2-9) becomes inactive. Then, this signal keeps the genset running.

This signal may come from any of these sources.

- PCC's Exercise Switch connection
- Operator Panel
- Modbus networks (page 1-4)
- PC-based service tool, such as InPower (page 1-6)
- Exercise scheduler (page 3-19) (internal function; no hardware connection)

This signal becomes active when one of the sources changes from inactive to active while all of the other sources remain inactive.

Note: This signal does not become active if the PCC is not in Auto mode when this change occurs.

When this signal becomes active, the PCC initiates a Non-emergency Start sequence (page 2-13) if the genset is not running already (for example, if the remote start signal was active).

This signal remains active for a length of time that depends on which source changed from inactive to active.

- If the source is the exercise scheduler, this signal remains active as long as the scheduler program (page 3-19) is running.
- If the source is one of the other sources, this signal remains active until the source becomes inactive or for *Genset Exercise Time*¹, whichever occurs first. (If the remote start signal becomes active or there is a shutdown fault, *Genset Exercise Time* is reset.)

If two or more sources are active at the same time, the logic is more complicated. This signal becomes inactive when one of these conditions is met.

- All of the sources become inactive.
- *Genset Exercise Time*² after the first source other than the exercise scheduler changed from inactive to active. However, the PCC resets the timer if all of the sources other than the exercise scheduler are inactive at the same time. At least one of the sources other than the exercise scheduler has to be active at all times, though it does not have to be the same source.

Note: The logic is even more complicated if the PCC leaves Auto mode or there is a shutdown fault. Please contact your local distributor if you have questions about specific scenarios.

When this signal becomes inactive, the PCC initiates a Shutdown with Cooldown sequence (page 2-16) if the remote start signal is inactive too.

Remote Start Signal

This signal has no effect unless these conditions are met.

- The PCC is in Auto mode (page 2-8).
- There are no active shutdown faults (page 5-1).

This signal may come from any of these sources.

- PCC Remote Start connection (typically, to a transfer switch)
- Modbus networks (page 1-4)
- PC-based service tool, such as InPower (page 1-6)

1. This parameter is not available in the Operator Panel. See Table 4-1 (page 4-1).
2. This parameter is not available in the Operator Panel. See Table 4-1 (page 4-1).

This signal becomes active when any of these sources is active. It remains active until all of the sources are inactive. If there are no sources (in other words, no connections), this signal is inactive.

Note: There are multiple sources for this signal. The genset keeps running if any source is active. You have to make all of the sources inactive to make the signal inactive.

When this signal becomes active, the PCC starts the genset if the genset is not running already. If the start type signal (page 2-9) is active, the PCC initiates a Non-emergency Start sequence (page 2-13). If the start type signal is inactive, the PCC initiates an Emergency Start sequence (page 2-11).

When this signal becomes inactive, the PCC initiates a Shutdown with Cooldown sequence (page 2-16) if the exercise signal (page 2-8) is inactive too.

Start Type Signal

This signal has no effect until the PCC starts the genset because the remote start signal (page 2-9) becomes active.

This signal may come from any of these sources.

- PCC Start Type connection
- Modbus networks (page 1-4)

This signal is active when any of these sources is active. It remains active until all of the sources are inactive. If there are no sources (in other words, no connections), this signal is inactive.

You can look at the current status of this signal in *Start Type Command Inputs*. If this parameter is zero, this signal is inactive. If this parameter is non-zero, this signal is active.

If this signal (page 2-9) is active, the PCC initiates a Non-emergency Start sequence (page 2-13) when the remote start signal becomes active.

If this signal is inactive, the PCC initiates an Emergency Start sequence (page 2-11) when the remote start signal becomes active.

⚠ CAUTION *The Emergency Start sequence wears out the engine sooner than the Non-emergency Start sequence. If it is not necessary to start the genset as quickly as possible (for ex-*

ample, when exercising or servicing the genset), the Non-emergency Start sequence is preferred. In some applications, however, you might not have any control over this.

Manual Mode

In this mode, the genset is controlled manually. Signals, such as the remote start signal (page 2-9), have no effect.

In applications where the Operator Panel controls the mode of operation, press the Manual button to put the PCC in Manual mode.

If the genset is running when the PCC enters this mode, the PCC keeps running the genset if the Start button is pressed within 250 ms. Otherwise, the PCC initiates a Shutdown without Cooldown sequence (page 2-18).

Press the Start button to initiate a Manual Start sequence (page 2-14).

Note: If you do not press the Start button in ten seconds, the PCC changes to Off mode.

Press the Stop button to initiate a Manual Stop sequence (page 2-17). When the Manual Stop sequence is done, the Operator Panel puts the PCC in Off mode (page 2-8).

POWER-DOWN MODE

The PCC and the Operator Panel can enter power-down mode, or sleep mode, to reduce power consumption when they are not being used.

Other devices in the genset consume additional current when the PCC and the Operator Panel are in power-down mode.

PCC Power-down Mode

Table 2-9 shows how much current the PCC consumes in normal operation and in power-down mode.

TABLE 2-9. PCC CURRENT CONSUMPTION

PCC MODE	CURRENT
Normal operation	750 mA
Power-down	5 mA

The PCC enters power-down mode when these conditions are met.

- *Power Down Mode Enable* is set to Enable.

- The *Power Down Mode Time Delay* has expired.
- The PCC is in Off mode (page 2-8) or Auto mode (page 2-8).
- If the PCC is in Auto mode, *Auto Sleep Enable* is set to Sleep in Auto.
- The genset is not running.
- Oil priming pump (page 1-3) is not active.
- There is no active Modbus communication (page 1-4).
- All of the wakeup signals (see below) are inactive.

In power-down mode, the microprocessor stops running; and PCCNet, Modbus, and PC-based service tool communications stop. If a connected device does not go into power-down mode with the PCC, this device might display a warning or error message.

In power-down mode, the real-time clock (page 3-6) and the CAN datalink with the engine control module (ECM) (page 1-2) remain on.

The PCC leaves power-down mode when any of these wakeup signals becomes active.

- Any active shutdown fault (page 5-1)
- Any active warning fault (page 5-2)
- Local Emergency Stop button (page 1-3)
- Remote Emergency Stop button (page 1-3)
- PCC Mode of Operation connection (*Auto mode configurable using Auto Sleep Enable*)
- Any System Wakeup connection (page 1-6)
- PCC Fault Reset connection (typically, the Reset button on the Operator Panel)
- Rupture Basin connection
- Low Fuel connection
- Coolant Level connection
- Remote Start connection (typically, to a transfer switch)

When the PCC leaves power-down mode, it resets *Power Down Mode Time Delay*.

For example, the PCC is in power-down mode. It receives a warning fault and exits power-down mode. The operator addresses the condition that caused the warning fault and acknowledges the fault. After *Power Down Mode Time Delay* expires, the PCC

enters power-down mode again (assuming it does not receive any other wakeup signals).

Operator Panel Power-down Mode

Table 2-10 shows how much current the Operator Panel consumes in normal operation and in power-down mode.

TABLE 2-10. OPERATOR PANEL CURRENT CONSUMPTION

OPERATOR PANEL MODE	CURRENT
Normal operation	150 mA (12 V)
	100 mA (24 V)
Power-down	1 mA

The PCC enters power-down mode when these conditions are met.

- The Operator Panel's *Sleep Mode* is set to Enable.
- The Operator Panel's *Sleep Timer* has expired.
- All of the wakeup signals (see below) are inactive.

The Operator Panel's *Sleep Mode* and *Sleep Timer* are available in the Display Options screen (page 3-6). These parameters are different than the PCC's parameters.

The Operator Panel leaves power-down mode when any of these wakeup signals becomes active.

- Pressing any button on the control panel (page 2-2)
- Any System Wakeup connection (page 1-6)

(Bidirectional) System Wakeup

Several devices can be connected to the same System Wakeup line. All of the devices on the same System Wakeup line enter and leave power-down mode simultaneously.

When any device in this connection is unable to enter power-down mode (for any reason other than the System Wakeup connection (page 1-6) being active), it sends a signal on its System Wakeup line(s). This signal prevents the other devices on the System Wakeup line(s) from entering power-down mode.

If a device is connected to more than one System Wakeup line and one of the System Wakeup lines is

active, the device sends a signal on all of the other System Wakeup lines as well.

SEQUENCES OF OPERATION

Sequences of operation describe the way the PCC starts the genset or stops the genset. This is illustrated in Figure 2-7.

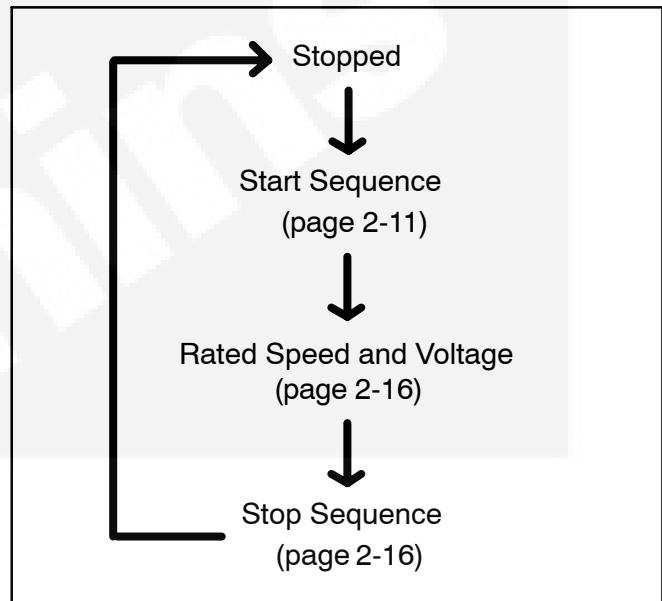

FIGURE 2-7. SEQUENCES OF OPERATION

Start Sequences

The PCC follows different start sequences depending on the current setup and conditions.

If a start sequence is interrupted for any reason except a shutdown fault (for example, the remote start signal becomes inactive), the PCC follows these steps to stop the genset.

- If the PCC has not started the engine yet, the PCC keeps the engine off.
- If the engine is running at idle speed or is ramping up to idle speed, the PCC stops the genset and deactivates any output signals that are connected to the fuel system.
- If the engine is running at rated speed or is ramping up to rated speed, the PCC follows the appropriate stop sequence (page 2-16).

Emergency Start

⚠ CAUTION *The Emergency Start sequence wears out the engine sooner than the Non-emergency Start sequence. If it is not necessary to start the genset as quickly as possible (for ex-*

ample, when exercising or servicing the gen-set), the Non-emergency Start sequence is preferred. In some applications, however, you might not have any control over this.

This sequence begins when these conditions are met.

- The PCC is in Auto mode (page 2-8).
- The remote start signal (page 2-9) is active.
- The start type signal (page 2-9) is inactive.
- There are no active shutdown faults.

This sequence is shown in Figure 2-8.

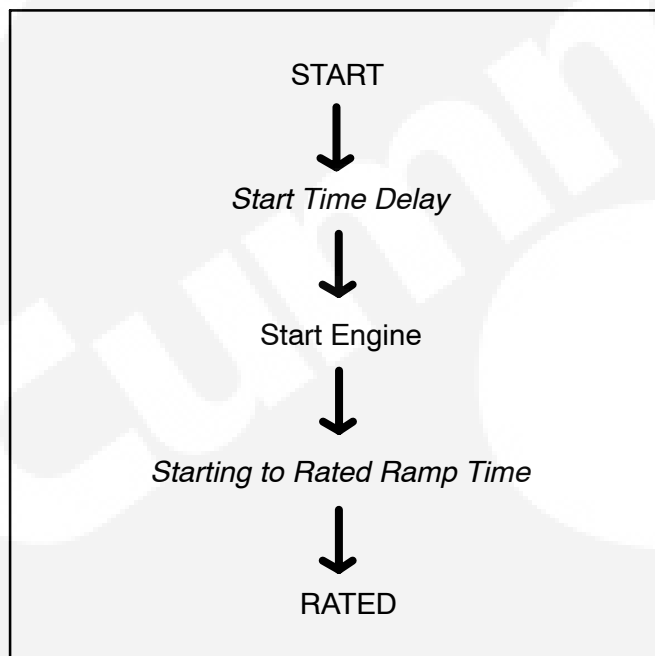

FIGURE 2-8. EMERGENCY START

In this sequence, the PCC follows these steps to start the engine.

1. The PCC waits until *Start Time Delay* expires.

If *Prelube Function Enable* is Enabled, the PCC turns on the oil-priming pump (page 1-3). The PCC turns off the oil-priming pump when one of these conditions is met.

- *Prelube Timeout Period* expires.
- The oil pressure is greater than or equal to *Prelube Oil Pressure Threshold*.

The PCC continues when *Start Time Delay* expires. It does not wait until the oil-priming pump is turned off.

2. The PCC turns on the fuel shutoff (FSO) control and switched B+ (run) control.

If *Delayed Off / Configurable Output #10 Output Function Pointer* is set to Default, the PCC turns on Delayed Off.

If *ECM CAN Enable* is set to Enable, the PCC turns on the ECM keyswitch.

If *Starter Owner* is set to GCS, the PCC turns on the starter for up to two seconds.

If the engine speed becomes greater than zero, the starter follows these rules.

- If *Cycle / Cont Crank Select* is Continuous, the starter remains on for *Continuous Crank Engage Time*.
- If *Cycle / Cont Crank Select* is Cycle, the starter turns on for *Cycle Crank Engage Time* and turns off for *Cycle Crank Rest Time*. The starter repeats this process up to *Crank Attempts* times.

Every time the engage time expires, the PCC checks the engine speed.

- If the engine speed is greater than *Starter Disconnect Speed*, the PCC stops cranking the engine.
- If the engine speed does not reach *Starter Disconnect Speed* before the PCC finishes cranking the engine, the PCC generates shutdown fault 359 (Fail To Start).

If the engine speed remains zero for two seconds, the PCC turns off the starter, waits for two seconds, and turns on the starter again.

If the engine speed remains zero two consecutive times, the PCC generates shutdown fault 1438 (Fail To Crank).

If *Starter Owner* is set to ECS, the PCC does not control the starter. The engine control module (ECM) or another device controls the starter.

3. The PCC raises the engine speed from starting to rated speed linearly during *Starting to Rated Ramp Time*.

The automatic voltage regulator (AVR) is enabled when these conditions are met.

- *AVR Enable*³ is set to Enable.
- The PCC is in Auto mode (page 2-8); or the PCC is in Manual mode (page 2-10), and *Excitation Disable Override* is Excitation On.

If these conditions are met, the PCC starts driving the field windings in the exciter when the engine speed reaches *Governor Enable Engine Speed*⁴. Then, it raises the voltage to rated voltage linearly during *Voltage Ramp Time*.

If these conditions are not met, the PCC does not drive the field windings in the exciter.

Non-emergency Start

This sequence begins when these conditions are met.

- The PCC is in Auto mode (page 2-8).
- The remote start signal (page 2-9) is active, and the start type signal (page 2-9) is active; or the exercise signal (page 2-8) is active, and the remote start signal is inactive.
- There are no active shutdown faults.

This sequence is shown in Figure 2-9.

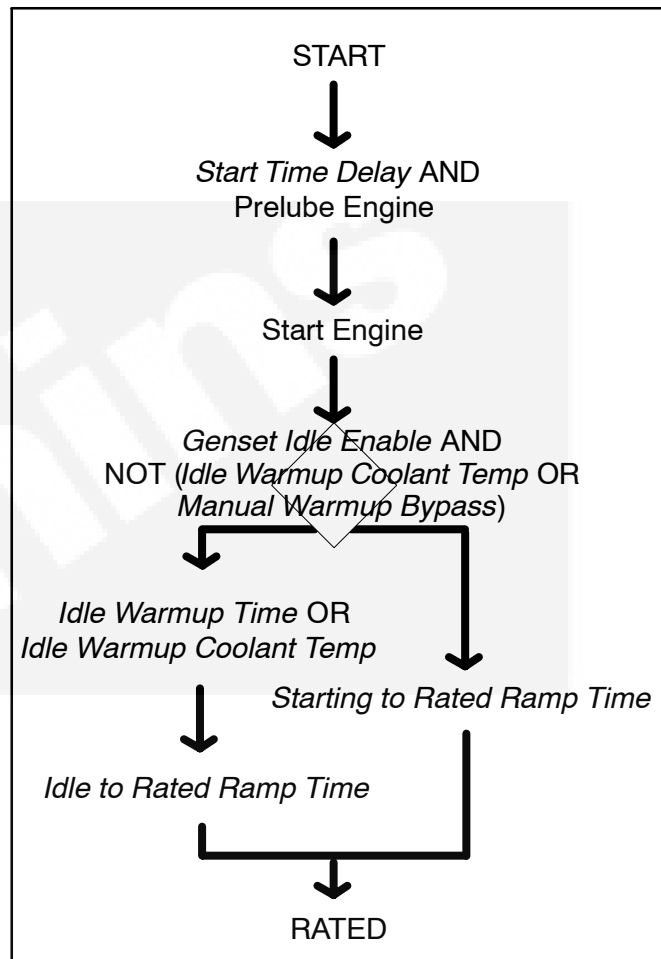

FIGURE 2-9. NON-EMERGENCY START

In this sequence, the PCC follows these steps to start the engine.

1. The PCC waits until *Start Time Delay* expires. If *Prelube Function Enable* is Enabled, the PCC turns on the oil-priming pump (page 1-3). The PCC turns off the oil-priming pump when one of these conditions is met.
 - *Prelube Timeout Period* expires.
 - The oil pressure is greater than or equal to *Prelube Oil Pressure Threshold*.

The PCC does not continue until both *Start Time Delay* expires and the oil-priming pump is turned off.

2. The PCC turns on the fuel shutoff (FSO) control and switched B+ (run) control. If *Delayed Off / Configurable Output #10 Output Function Pointer* is set to Default, the PCC turns on Delayed Off.

3. This parameter is not available in the Operator Panel. See Table 4-1 (page 4-1).

4. This parameter is not available in the Operator Panel. See Table 4-1 (page 4-1).

If *ECM CAN Enable* is set to Enable, the PCC turns on the ECM keyswitch.

If *Starter Owner* is set to GCS, the PCC turns on the starter for up to two seconds.

If the engine speed becomes greater than zero, the starter follows these rules.

- If *Cycle / Cont Crank Select* is Continuous, the starter remains on for *Continuous Crank Engage Time*.
- If *Cycle / Cont Crank Select* is Cycle, the starter turns on for *Cycle Crank Engage Time* and turns off for *Cycle Crank Rest Time*. The starter repeats this process up to *Crank Attempts* times.

Every time the engage time expires, the PCC checks the engine speed.

- If the engine speed is greater than *Starter Disconnect Speed*, the PCC stops cranking the engine.
- If the engine speed does not reach *Starter Disconnect Speed* before the PCC finishes cranking the engine, the PCC generates shutdown fault 359 (Fail To Start).

If the engine speed remains zero for two seconds, the PCC turns off the starter, waits for two seconds, and turns on the starter again.

If the engine speed remains zero two consecutive times, the PCC generates shutdown fault 1438 (Fail To Crank).

If *Starter Owner* is set to ECS, the PCC does not control the starter. The engine control module (ECM) or another device controls the starter.

3. This step depends on whether or not any of these conditions is met.

- The coolant temperature is already greater than *Idle Warmup Coolant Temp*.
- *Genset Idle Enable* is set to Disabled.

If none of the conditions is met, the PCC runs the engine at idle speed for *Idle Warmup Time* or until the coolant temperature reaches *Idle Warmup Coolant Temp*. Then, the PCC raises the engine speed from idle speed to rated speed linearly during *Idle to Rated Ramp Time*.

If at least one condition is met, the PCC raises the engine speed from starting to rated speed linearly during *Starting to Rated Ramp Time*.

The automatic voltage regulator (AVR) is enabled when these conditions are met.

- *AVR Enable*⁵ is set to Enable.
- The PCC is in Auto mode (page 2-8); or the PCC is in Manual mode (page 2-10), and *Excitation Disable Override* is Excitation On.

If these conditions are met, the PCC starts driving the field windings in the exciter when the engine speed reaches *Governor Enable Engine Speed*⁶. Then, it raises the voltage to rated voltage linearly during *Voltage Ramp Time*.

If these conditions are not met, the PCC does not drive the field windings in the exciter.

Manual Start

This sequence begins when these conditions are met.

- The PCC is in Manual mode (page 2-10).
- In applications where the Operator Panel controls the mode of operation, the Start button is pressed.
- There are no active shutdown faults.



5. This parameter is not available in the Operator Panel. See Table 4-1 (page 4-1).

6. This parameter is not available in the Operator Panel. See Table 4-1 (page 4-1).

This sequence is shown in Figure 2-10.

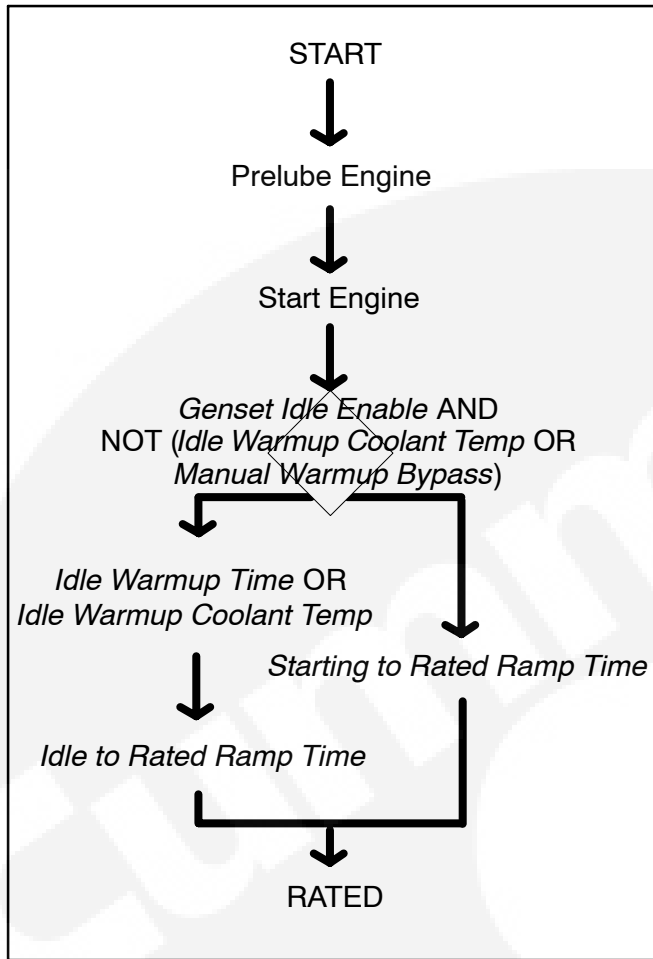

FIGURE 2-10. MANUAL START SEQUENCE

In this sequence, the PCC follows these steps to start the engine.

1. If *Prelube Function Enable* is Enabled, the PCC turns on the oil-priming pump (page 1-3). The PCC turns off the oil-priming pump when one of these conditions is met.

- *Prelube Timeout Period* expires.
- The oil pressure is greater than or equal to *Prelube Oil Pressure Threshold*.

2. The PCC turns on the fuel shutoff (FSO) control and switched B+ (run) control.

If *Delayed Off / Configurable Output #10 Output Function Pointer_* is set to Default, the PCC turns on Delayed Off.

If *ECM CAN Enable* is set to Enable, the PCC turns on the ECM keyswitch.

7. This parameter is not available in the Operator Panel. See Table 4-1 (page 4-1).

If *Starter Owner* is set to GCS, the PCC turns on the starter for up to two seconds.

If the engine speed becomes greater than zero, the starter follows these rules.

- If *Cycle / Cont Crank Select* is Continuous, the starter remains on for *Continuous Crank Engage Time*.
- If *Cycle / Cont Crank Select* is Cycle, the starter turns on for *Cycle Crank Engage Time* and turns off for *Cycle Crank Rest Time*. The starter repeats this process up to *Crank Attempts* times.

Every time the engage time expires, the PCC checks the engine speed.

- If the engine speed is greater than *Starter Disconnect Speed*, the PCC stops cranking the engine.
- If the engine speed does not reach *Starter Disconnect Speed* before the PCC finishes cranking the engine, the PCC generates shutdown fault 359 (Fail To Start).

If the engine speed remains zero for two seconds, the PCC turns off the starter, waits for two seconds, and turns on the starter again.

If the engine speed remains zero three consecutive times, the PCC generates shutdown fault 1438 (Fail To Crank).

If *Starter Owner* is set to ECS, the PCC does not control the starter. The engine control module (ECM) or another device controls the starter.

3. If *Genset Idle Enable* is Disabled, the PCC raises the engine speed from starting to rated speed linearly during *Starting to Rated Ramp Time*.

If *Genset Idle Enable* is Enabled and *Rated/Idle Switch (PCCnet)* is Idle, the PCC runs the engine at idle speed. This is a type of idle request (page 2-19).

If *Genset Idle Enable* is Enabled and *Rated/Idle Switch (PCCnet)* is Rated, this step depends on whether or not any of these conditions is met.

- The coolant temperature is already greater than *Idle Warmup Coolant Temp*.
- *Manual Warmup Bypass*⁷ is set to Bypass Warmup.

If none of the conditions is met, the PCC runs the engine at idle speed for *Idle Warmup Time*

or until the coolant temperature reaches *Idle Warmup Coolant Temp*. Then, the PCC raises the engine speed from idle speed to rated speed linearly during *Idle to Rated Ramp Time*.

If at least one condition is met, the PCC raises the engine speed from starting to rated speed linearly during *Starting to Rated Ramp Time*.

The automatic voltage regulator (AVR) is enabled when these conditions are met.

- *AVR Enable*⁸ is set to Enable.
- The PCC is in Auto mode (page 2-8); or the PCC is in Manual mode (page 2-10), and *Excitation Disable Override* is Excitation On.

If these conditions are met, the PCC starts driving the field windings in the exciter when the engine speed reaches *Governor Enable Engine Speed*⁹. Then, it raises the voltage to rated voltage linearly during *Voltage Ramp Time*.

If these conditions are not met, the PCC does not drive the field windings in the exciter.

Rated Speed and Voltage

Rated speed is based on the speed reference. Rated voltage is based on the voltage setpoint.

Speed Reference

The PCC follows these steps to calculate the speed reference.

1. Add these frequencies together.
 - *Alternate Frequency Switch*
 - *Frequency Adjust*
2. Limit the sum of these values to 60%–110% of *Alternate Frequency Switch*.
3. Multiply this value by *Frequency to Speed Gain Select*.

If *ECM CAN Enable* is set to Enable, the PCC sends the speed bias reference to the ECM. The speed bias reference is the percent difference between the speed reference and the base speed (*Alternate Frequency Switch* multiplied by *Frequency to Speed Gain Select*).

8. This parameter is not available in the Operator Panel. See Table 4-1 (page 4-1).
9. This parameter is not available in the Operator Panel. See Table 4-1 (page 4-1).

Voltage Setpoint

The PCC follows these steps to calculate the voltage setpoint.

1. Add these percentages together.
 - 100% (for *Genset Nominal Voltage*)
 - *Voltage Adjust*
 - Watt Sentry (page 2-19)
2. Subtract the V/Hz Curve (page 3-18) reductions.

The voltage setpoint is expressed as a percentage of *Genset Nominal Voltage*.

The PCC tries to keep the following voltages at the voltage setpoint.

- *Genset Average Voltage%*
- *Genset 3 Phase Fast Average Voltage Percent*

If the genset current reaches 300% of its rated value, the PCC stops monitoring voltage and tries to reduce the genset current to less than 150% of its rated value. Then, it stops monitoring the genset current and starts monitoring genset voltage again.

Stop Sequences

The PCC follows different stop sequences depending on the current setup and conditions.

If a stop sequence is interrupted, the PCC follows these steps to restart the genset.

- If the engine is still running at rated speed, the PCC keeps running the genset at rated speed and voltage. (page 2-16).
- If the engine is running at idle speed or is ramping down to idle speed, the PCC raises the engine speed from the current speed to rated speed linearly during *Idle to Rated Ramp Time*. The PCC also starts the automatic voltage regulator (AVR), if applicable.

Shutdown with Cooldown

This sequence begins when these conditions are met.

- The PCC is in Auto mode (page 2-8).
- The genset is running at rated speed and voltage (page 2-16).
- The remote start signal (page 2-9) is inactive.

- The exercise signal (page 2-8) is inactive.
- There are no active shutdown faults.

This sequence is shown in Figure 2-11.

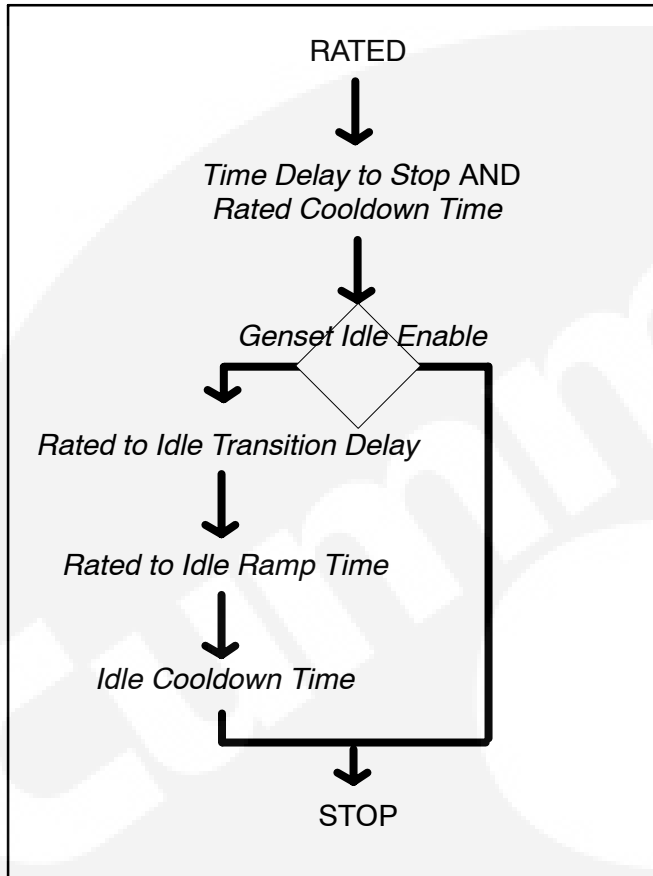

FIGURE 2-11. SHUTDOWN WITH COOLDOWN SEQUENCE

In this sequence, the PCC follows these steps to stop the genset.

1. The PCC runs the genset at rated speed and voltage until these conditions are met.
 - *Time Delay to Stop* expires.
 - The genset runs at less than 10% of the rated load for *Rated Cooldown Time*.

The PCC waits indefinitely for the load to drop below 10% if *Rated Cooldown Time* is greater than zero.

2. If *Genset Idle Enable* is set to Disabled, the PCC stops the genset. The PCC turns off the fuel shutoff (FSO) control. If *ECM CAN Enable* is set to Enable, the PCC turns off the ECM key-

switch. The PCC stops driving the field windings in the exciter.

If *Genset Idle Enable* is set to Enabled, the PCC follows these steps.

- A. The PCC runs the engine at rated speed for *Rated to Idle Transition Delay*. If *Rated to Idle Transition Delay* is greater than zero, event code 1122 (Rated to Idle Transition) becomes active.
- B. The PCC reduces the engine speed from rated speed to idle speed linearly during *Rated to Idle Ramp Time*.

Note: If *ECM CAN Enable* is Enable, the ECM, not the PCC, actually controls the transition from rated speed to idle speed.

- C. The PCC stops the automatic voltage regulator (AVR).
- D. The PCC runs the engine at idle speed for *Idle Cooldown Time*.
- E. The PCC stops the genset. The PCC turns off the fuel shutoff (FSO) control. If *ECM CAN Enable* is set to Enable, the PCC turns off the ECM keyswitch. Event code 1122 (Rated to Idle Transition) becomes inactive.

The PCC stops driving the field windings in the exciter when the PCC stops running the engine at rated speed.

If *Delayed Off / Configurable Output #10 Output Function Pointer* is set to Default, the PCC turns off *Delayed Off Delayed Off FSO Relay Time* after the PCC stops the genset.

Manual Stop

This sequence begins when these conditions are met.

- The PCC is in Manual mode (page 2-10).
- The genset is running at rated speed and voltage (page 2-16).
- In applications where the Operator Panel controls the mode of operation, the Stop button is pressed once.
- There are no active shutdown faults.

This sequence is shown in Figure 2-12.

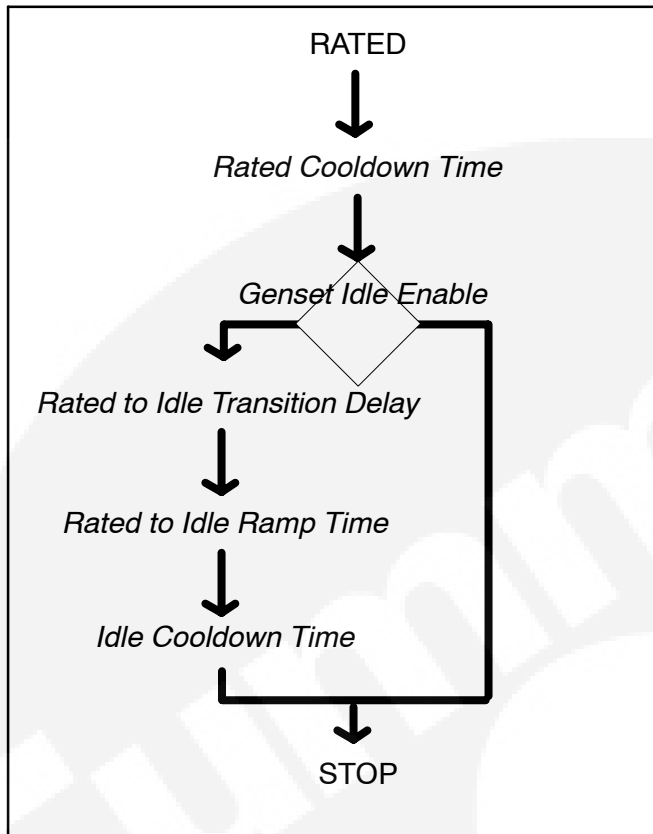

FIGURE 2-12. MANUAL STOP SEQUENCE

In this sequence, the PCC follows these steps to stop the genset.

1. The PCC runs the genset at rated speed and voltage until the genset runs at less than 10% of the rated load for *Rated Cooldown Time*. The PCC waits indefinitely for the load to drop below 10% if *Rated Cooldown Time* is greater than zero.
2. If *Genset Idle Enable* is set to Disabled, the PCC stops the genset. The PCC turns off the fuel shutoff (FSO) control. If *ECM CAN Enable* is set to Enable, the PCC turns off the ECM key-switch. The PCC stops driving the field windings in the exciter.

If *Genset Idle Enable* is set to Enabled, the PCC follows these steps.

- A. The PCC reduces the engine speed from rated speed to idle speed linearly during *Rated to Idle Ramp Time*.

Note: If *ECM CAN Enable* is Enable, the ECM, not the PCC, actually controls the transition from rated speed to idle speed.

- B. The PCC stops the automatic voltage regulator (AVR).
- C. The PCC runs the engine at idle speed for *Idle Cooldown Time*.
- D. The PCC stops the genset. The PCC turns off the fuel shutoff (FSO) control. If *ECM CAN Enable* is set to Enable, the PCC turns off the ECM key-switch. Event code 1122 (Rated to Idle Transition) becomes inactive.

The PCC stops driving the field windings in the exciter when the PCC stops running the engine at rated speed.

If *Delayed Off / Configurable Output #10 Output Function Pointer_* is set to Default, the PCC turns off *Delayed Off Delayed Off FSO Relay Time* after the PCC stops the genset.

Shutdown Without Cooldown

This sequence begins when one of these conditions is met.

- A shutdown fault (page 5-1) with a response of Shutdown Without Cooldown initiates it.
- The genset is running when the PCC enters Off mode (page 2-8).
- The genset is running when the PCC enters Manual mode (page 2-10) and the Start button is not pressed in 250 ms.

This sequence is shown in Figure 2-12.



FIGURE 2-13. SHUTDOWN WITHOUT COOLDOWN SEQUENCE

The PCC ignores timers and loads and stops the genset immediately.

If *Delayed Off / Configurable Output #10 Output Function Pointer_* is set to Default, the PCC turns off *Delayed Off Delayed Off FSO Relay Time* after the PCC stops the genset.

IDLE REQUESTS

Idle requests make the PCC run the genset at idle speed, instead of rated speed and voltage (page 2-16).

An idle request becomes active when all of these conditions are met.

- The PCC is in Manual mode (page 2-10).
- *Genset Idle Enable* is set to Enabled.
- *Rated/Idle Switch (PCCnet)* is set to Idle. (*Rated/Idle Switch (PCCnet)* is available in the Operator Panel.)
- There are no active shutdown faults.

If *Genset Idle Enable* is set to Disabled while an idle request is active, the idle request remains active. If any of the other conditions become untrue while an idle request is active, the idle request becomes inactive.

The PCC's response depends on the initial state of the genset and the final state of the genset.

Stop to Idle Speed

The PCC initiates a Manual Start sequence (page 2-14).

Rated Speed to Idle Speed

1. The PCC runs the engine at rated speed for *Rated to Idle Transition Delay*. If *Rated to Idle Transition Delay* is greater than zero, event code 1122 (Rated to Idle Transition) becomes active.
2. The PCC stops driving the field windings in the exciter and reduces the engine speed from rated speed to idle speed linearly during *Rated to Idle Ramp Time*.

Note: If *ECM CAN Enable* is Enable, the ECM, not the PCC, actually controls the transition from rated speed to idle speed and the idle speed itself.

Event code 1122 (Rated to Idle Transition) remains active as long as the PCC remains at idle speed.

10. This parameter is not available in the Operator Panel. See Table 4-1 (page 4-1).
11. This parameter is not available in the Operator Panel. See Table 4-1 (page 4-1).
12. This parameter is not available in the Operator Panel. See Table 4-1 (page 4-1).

Idle Speed to Stop

The PCC stops the genset. The PCC turns off the fuel shutoff (FSO) control. If *ECM CAN Enable* is set to Enable, the PCC turns off the ECM keyswitch. Event code 1122 (Rated to Idle Transition) becomes inactive.

Idle Speed to Rated Speed

1. The PCC waits until one of these conditions is met.
 - The genset was running at rated speed and voltage (page 2-16) before it started running at idle speed. In other words, the PCC made a rated-speed-to-idle-speed transition (page 2-19) to get to idle speed.
 - The engine has been running at idle speed for *Idle Warmup Time*.
 - The coolant temperature is already greater than *Idle Warmup Coolant Temp*.
 - *Manual Warmup Bypass*¹⁰ is set to Bypass Warmup.

Then, event code 1122 (Rated to Idle Transition) becomes inactive.

2. The PCC raises the engine speed from idle speed to rated speed linearly during *Idle to Rated Ramp Time*.

The automatic voltage regulator (AVR) is enabled when these conditions are met.

- *AVR Enable*¹¹ is set to Enable.
- The PCC is in Auto mode (page 2-8); or the PCC is in Manual mode (page 2-10), and *Excitation Disable Override* is Excitation On.

If these conditions are met, the PCC starts driving the field windings in the exciter when the engine speed reaches *Governor Enable Engine Speed*¹². Then, it raises the voltage to rated voltage linearly during *Voltage Ramp Time*.

If these conditions are not met, the PCC does not drive the field windings in the exciter.

WATT SENTRY

This feature may be enabled by the factory for specific applications. It is disabled by default.

The main purpose of this feature is to prevent excessive buildups of intake manifold pressure from a turbocharger in gas-based engines.

The PCC reduces the voltage setpoint (page 2-16) to reduce the kW output of the engine and, in turn, the intake manifold pressure. If the kW output remains high, the PCC keeps lowering the voltage setpoint until the PCC generates shutdown fault 1447 (Low AC Voltage) to protect the engine.

SETUP MODE

This mode lets you set up the PCC without starting the genset accidentally. In Setup mode, the PCC does not allow the genset to start and forces all outputs into off (de-energized) states.

Note: This mode is required to set up some parameters.

The PCC enters Setup mode when these conditions are met.

- *Setup Mode Enable* is set to Enable.

- The genset is not running.

When the PCC enters Setup mode, the *Setup Mode Timer*¹³ is initialized to *Max Setup Mode Time*¹⁴. This timer is reset each time you save a parameter. The PCC exits Setup mode when the timer expires or when you set *Setup Mode Enable* to Disable.

Note: The Operator Panel handles Setup mode automatically.

The Operator Panel handles Setup mode for you. If you adjust a parameter that has to be modified in Setup mode, the Operator Panel automatically tries to put the PCC in Setup mode before it saves the change. If the PCC cannot enter Setup mode (for example, the genset is running), the Operator Panel displays an error message. Otherwise, the PCC saves the change, and the Operator Panel tells the PCC to leave Setup mode.



13. This parameter is not available in the Operator Panel. See Table 4-1 (page 4-1).

14. This parameter is not available in the Operator Panel. See Table 4-1 (page 4-1).

3. Setup and Calibration

Read **Safety Precautions**, and carefully observe all of the instructions and precautions in this manual.

CAUTION *Only qualified technicians should adjust the parameters described in this section. Failure to follow this may affect genset operation and may cause damage to the genset or to equipment connected to the genset.*

In this section, *italics* are used to identify a specific parameter by name.

PARAMETERS

See Section 4 for more information about parameters that you can adjust in the Operator Panel.

Passwords

You can look at the value of every parameter in the Operator Panel. If you want to adjust a parameter, the PCC might prompt you for a password.

The PCC supports these password levels.

TABLE 3-1. PASSWORD LEVELS

LEVEL	DESCRIPTION	VALUE
0	No password	None
1	Operator password	574
2	Service password	Restricted
3	Engineering password	Restricted

When the PCC prompts you for a password, it tells you what level password is required. You should provide the password for the requested level or for a higher level. For example, the PCC accepts the level-2 password even if it only requires the level-1 password.

If the password is shorter than the number of digits in the Operator Panel, enter the password on the right side of this field. For example, if the password is 456 and the Operator Panel requests five digits, enter "00456".

TABLE 3-2. MENU DESCRIPTION

MENU	DESCRIPTION
Genset Data	Use this screen to look at the status of the genset.
Engine Data	Use this screen to look at the status of the engine.

When you provide a valid password, the PCC unlocks all of the parameters at the level of the provided password and lower. For example, if you enter a level-2 password, the PCC unlocks all parameters in level 0, 1, or 2. The parameters remain unlocked until the Operator Panel is inactive for five minutes.

Mode Change Password

If Mode Change is Enabled in the Display Options screen (page 3-6), you have to enter the password 121 when you use the Operator Panel to change the mode of operation (page 2-8).

Capture File

Use InPower to save the current settings in a capture file on a PC or network. You can use the capture file to look at the current settings while you are away from the PCC or to restore settings if you have to reset the PCC for any reason. See the InPower User Guide for more information.

Override Parameters

For troubleshooting, you can override the value of some inputs and some outputs.

For discrete values, set the corresponding *Override Enable* parameter to Enable to set the input value or output value to the corresponding *Override Command* or *Override Cmd*. For example, follow these steps if you want to turn off the ECM keyswitch.

1. Set *Keyswitch Override Cmd* to Inactive.
2. Set *Keyswitch Override Enable* to Enable.

Set *Override Cmd* before you set *Override Enable*.

For analog values, set the corresponding *Override Enable* parameter to Enable to set the output value to the corresponding *Override Value*.

MENU DESCRIPTION

Table 3-2 shows a summary of the menus in the PCC.

MENU		DESCRIPTION
Alternator Data		Use this screen to look at the status of the alternator.
Faults		
	Shutdown Faults	Use this screen to look at active shutdown faults (page 5-1).
	Warning Faults	Use this screen to look at active warning faults (page 5-2).
	Fault History	Use this screen to look at faults that have been cleared.
Help		Use this screen to get more information about each component in the control panel (page 2-2).
Setup		
	Display Options	Use this screen to configure the Operator Panel.
	Clock Setup	Use this screen to configure the real-time clock (page 3-6).
	Modbus Setup	Use this screen to set up the PCC for Modbus networks (page 1-4).
	Adjust Droop	Use this screen to configure certain adjustments, overrides, and gains.
	Calibration Setup	Use this screen to calibrate the PCC.
	Configurable IO	Use this screen to set up the configurable inputs (page 3-10) and the configurable outputs (page 3-12).
	Genset Setup	Use this screen to configure sequences of operation (page 2-11), genset-related faults, and the exercise scheduler (page 3-19).
	PCC Net	Use this screen to set up the PCC for PCCNet devices (page 1-4).
	OEM Setup	
	Alternator Setup	Use this screen to configure voltage limits, main alternator connections, alternator-related faults, AVR coefficients, and other detailed alternator settings.
	Engine Setup	Use this screen to configure battery-related faults and other detailed engine settings.
	Genset Setup	Use this screen to configure application ratings, factory locks, and other detailed genset settings.
Save Restore		This is reserved for future use.
History-About		Use this screen to look at historical information about the genset.
Advanced Status		
	Genset Status	Use this screen to look at power, energy, phase differences, and other detailed genset information.
	Controller Status	Use this screen to look at sequences of operation (page 2-11), configurable inputs (page 3-10), configurable outputs (page 3-12), and other detailed PCC information.
	Engine Status	Use this screen to look at pressures, voltages, temperatures, and other detailed engine information.
Paralleling		
	Paralleling Status	This is reserved for future use.
	Paralleling Setup	This is reserved for future use.
Load Demand Status		This is reserved for future use.
Power Status		This is reserved for future use.

GENSET DATA

Each label is described in the following table.

TABLE 3-3. GENSET DATA

NAME	DESCRIPTION
Avg Voltage	Genset Line to Line average voltage Parameter: Genset LL Average Voltage.
Avg Current	Genset average current Parameter: Genset Average Current.
Total kW	Genset total kW Parameter: Genset Total kW.
Total PF	Genset power factor Parameter: Genset Total Power Factor.
Frequency	Genset frequency Parameter: Genset Frequency.
Coolant Temp	Monitor point for the Coolant Temperature Parameter: Coolant Temperature.
Engine Hrs	Total engine run time Parameter: Engine Running Time.
Oil Pressure	Monitor point for the Oil Pressure Parameter: Oil Pressure. Allowed values: 0~145 psi.
Batt Voltage	Battery voltage value. Parameter: Battery Voltage.
% Torq/Duty	Monitor point for the percent engine torque output and the governor percent duty cycle output when used with the HM ECM Parameter: Percent Engine Torque/Duty Cycle. Allowed values: -125~125 %.
Fuel Rate	Monitor point for the Fuel Rate Parameter: Fuel Rate. Allowed values: 0~845 gal/hr.
Fuel Cons.	Fuel consumption since last reset. Parameter: Fuel Consumption Since Reset.
Tot Fuel C.	Total fuel consumption since start of engine. Parameter: Total Fuel Consumption.
Genset Application Rating	
kW Rating	The genset kW rating. Parameter: Genset Application kW rating.
kVA Rating	The genset KVA rating. Parameter: Genset Application kVA rating.
Rated Current	The value of the genset application nominal current. Parameter: Genset Application Nominal Current.
Genset Standby Rating	
kW Rating	KW rating for the genset in Standby configuration. Parameter: Genset Standby kW rating.
kVA Rating	KVA rating for the genset in Standby configuration. Parameter: Genset Standby kVA rating.
Rated Current	The value of the genset standby nominal current. Parameter: Genset Standby Nominal Current.

ENGINE DATA

Each label is described in the following table.

TABLE 3-4. ENGINE DATA

NAME	DESCRIPTION
Engine Hours	Total engine run time Parameter: Engine Running Time.
Coolant Temp	Monitor point for the Coolant Temperature Parameter: Coolant Temperature.
Engine Speed	Monitor point for the Average Engine Speed Parameter: Average Engine Speed.

NAME	DESCRIPTION
Batt Voltage	Battery voltage value. Parameter: Battery Voltage.
Oil Pressure	Monitor point for the Oil Pressure Parameter: Oil Pressure. Allowed values: 0~145 psi.
Oil Temp	Monitor point for the Oil Temperature Parameter: Oil Temperature. Allowed values: -40~410 degF.
Manf Temp	Monitor point for the Intake Manifold Temperature Parameter: Intake Manifold Temperature. Allowed values: -40~410 degF.
Boost Pres	Monitor point for the Boost Absolute Pressure Parameter: Boost Pressure. Allowed values: 0~148 psi.
Rail Press Abs	Monitor point for the Fuel Outlet Pressure Pressure Parameter: Fuel Outlet Pressure. Allowed values: 0~36404 psi.
Fuel Inlet Temp	Monitor point for the Fuel Temperature Parameter: Fuel Temperature. Allowed values: -40~410 degF.
Coolant Press	Monitor point for the Coolant Pressure. Parameter: Coolant Pressure. Allowed values: 0~145 psi.
Pump Press Abs	Monitor point for the Fuel Supply Pressure Parameter: Fuel Supply Pressure. Allowed values: 0~145 psi.
Crank Press	Monitor point for the Crankcase Pressure. Parameter: Crankcase Pressure. Allowed values: -35.67~38 psi.
Aftercooler Temp	Monitor point for the Aftercooler Temperature. Parameter: Aftercooler Temperature. Allowed values: -40~410 degF.
Ambient Press	Monitor point for the Barometric Absolute Pressure Parameter: Barometric Absolute Pressure. Allowed values: 0~37 psi.

ALTERNATOR DATA

Each label is described in the following table.

TABLE 3-5. ALTERNATOR DATA

NAME	DESCRIPTION
L1 L2 L3	Alternator terminals.
LL(Vac)	Genset L1L2 voltage Parameter: Genset L1L2 Voltage. Genset L2L3 voltage Parameter: Genset L2L3 Voltage. Genset L3L1 voltage Parameter: Genset L3L1 Voltage.
LN(Vac)	Genset L1N voltage Parameter: Genset L1N Voltage. Genset L2N voltage Parameter: Genset L2N Voltage. Genset L3N voltage Parameter: Genset L3N Voltage.

NAME	DESCRIPTION
Amps	Monitors the genset L1 current value. Parameter: Genset L1 Current. Genset L2 current Parameter: Genset L2 Current. Genset L3 current Parameter: Genset L3 Current.
kW	Genset L1 kW Parameter: Genset L1 kW. Genset L2 kW Parameter: Genset L2 kW. Genset L3 kW Parameter: Genset L3 kW.
kVA	Genset L1 kVA Parameter: Genset L1 KVA. Genset L2 kVA Parameter: Genset L2 KVA. Genset L3 kVA Parameter: Genset L3 KVA.
PF	Genset L1 power factor Parameter: Genset L1 Power Factor. Genset L2 power factor Parameter: Genset L2 Power Factor. Genset L3 power factor Parameter: Genset L3 Power Factor.
Total kW	Genset total kW Parameter: Genset Total kW.
Total kVA	Genset total kVA Parameter: Genset Total KVA.
Total PF	Genset power factor Parameter: Genset Total Power Factor.
Frequency	Genset frequency Parameter: Genset Frequency.
AVR Duty Cycle	The AVR PWM software command. Linear relationship between counts and % duty cycle with 10000 counts=100% duty cycle Parameter: AVR PWM Command.

FAULTS (FAULTS AND WARNINGS)

Use this screen to select one of these screens.

Shutdown Faults (Active Shutdowns)

This screen displays up to five faults.

The same event/fault code appears multiple times if it comes from different sources; for example, some gensets have multiple engine control modules (ECMs), or the same event/fault code can come from the PCC and ECM.

Each label is described in the following table.

TABLE 3-6. SHUTDOWN FAULTS (ACTIVE SHUTDOWNS)

NAME	DESCRIPTION
Flt #	This is the fault code.
SA	This is the controller that identified the fault. It is blank if the PCC identified the fault.
Gen Response	This is the type of fault (page 5-1) that was generated.
Engine Hours	This is how many hours the engine had run (not necessarily continuously) when the fault was generated.
mm/dd/yy	This is the date the fault was generated.
hh/mm/ss	This is the time the fault was generated.

Warning Faults (Active Warnings)

This screen displays up to thirty-two faults.

The same event/fault code appears multiple times if it comes from different sources.

Each label is described in the following table.

TABLE 3-7. WARNING FAULTS (ACTIVE WARNINGS)

NAME	DESCRIPTION
Flt #	This is the fault code.
SA	This is the controller that identified the fault. It is blank if the PCC identified the fault.
Gen Response	This is the type of fault (page 5-1) that was generated.
Engine Hours	This is how many hours the engine had run (not necessarily continuously) when the fault was generated.
mm/dd/yy	This is the date the fault was generated.
hh/mm/ss	This is the time the fault was generated.

Fault History

The same event/fault code appears multiple times if it comes from different sources.

This screen displays up to thirty-two faults.

Each label is described in the following table.

TABLE 3-8. FAULT HISTORY

NAME	DESCRIPTION
Flt #	This is the fault code.
SA	This is the controller that identified the fault. It is blank if the PCC identified the fault.
Engine Hours	This is how many hours the engine had run (not necessarily continuously) when the fault was generated.
mm/dd/yy	This is the date the fault was generated.
hh/mm/ss	This is the time the fault was generated.

HELP

Use this screen to get more information about each component in the control panel (page 2-2).

SETUP

Use this screen to select one of these screens.

Display Options

Each label is described in the following table.

TABLE 3-9. DISPLAY OPTIONS

NAME	DESCRIPTION
Power Mgmt	This controls how the Operator Panel uses and conserves power.
Units	This controls the unit of measure used in the Operator Panel.
Language	This is the language used in the Operator Panel.
Mode Change	This indicates whether or not a password is required to use the buttons on the Operator Panel to change the mode of operation (page 2-8). If this is set to Enabled, the password is required. If this is set to Disabled, the password is not required. This has no effect if a keyswitch controls the mode of operation.
Backlight Timer	This is how long the Operator Panel remains backlit when there is no activity with the control panel. Power Mgmt must be set to Max.
Sleep Timer	This is how many minutes the Operator Panel waits when there is no activity with the control panel before it can enter power-down mode (page 2-11). The Operator Panel does not enter power-down mode until the PCC enters power-down mode.
Sleep Mode	This indicates whether or not power-down mode is enabled in the Operator Panel.
Contrast	This controls the contrast in the graphical display.

Clock Setup**Real-time Clock**

The PCC has a real-time clock that is used to calculate how long the controller has been on and to support the schedulers (page 3-19). The clock displays time in 24-hour format and recognizes dates until 2100.

You can also set up daylight saving time. When daylight saving time begins, the PCC adds *Daylight Savings Time Adjustment* to the clock. If you disable daylight saving time before daylight saving time ends, the PCC does not automatically subtract *Daylight Savings Time Adjustment* from the clock. You have to adjust the clock manually.

If the battery is disconnected from the PCC, the real-time clock continues to run for about one hour.

Afterwards, the PCC generates warning fault 1689 (Real Time Clock Power), and the clock has to be re-set. Each label is described in the following table.

TABLE 3-10. CLOCK SETUP

NAME	DESCRIPTION
Clock Setup	
Clock Mode	Use to set the real time clock and save settings. Parameter: Clock Mode. (Password level: 1.) Allowed values: Normal, Set Clock, Save Clock. (Default: Normal.)
HH	Use to set or read the current hour. Parameter: Clock Hour. (Password level: 1.) Allowed values: 0~23.
MM	Use to set or read the current minute. Parameter: Clock Minute. (Password level: 1.) Allowed values: 0~59.
SS	Use to set or read the current second. Parameter: Clock Second. (Password level: 1.) Allowed values: 0~59.
DD	Use to set or read the current date. Parameter: Clock Date. (Password level: 1.) Allowed values: 1~31.
MM	Use to set or read the current month. Parameter: Clock Month. (Password level: 1.) Allowed values: 1~12.
YY	Use to set or read the current year. Parameter: Clock Year. (Password level: 1.) Allowed values: 0~99.
Daylight Saving Adjust	
Saving Time	Use to enable the daylight savings time feature. Parameter: Daylight Savings Time Enable. (Password level: 1.) Allowed values: Disabled, Enabled. (Default: Disabled.)
Adjustment	Use to set the amount of daylight savings time adjustment applied. Parameter: Daylight Savings Time Adjustment. (Password level: 1.) Allowed values: 0~120 Minutes. (Default: 60 Minutes.)
Start	
Month	Use to set the month when daylight savings time starts. Parameter: Daylight Savings Start Month. (Password level: 1.) Allowed values: 1~12. (Default: 4.)
Week	Use to set the week of the month when daylight savings time starts. Parameter: Daylight Savings Start Week. (Password level: 1.) Allowed values: First Week, Second Week, Third Week, Fourth Week, Last Week. (Default: First Week.)
Day	Use to set the day of the week when daylight savings time starts. Parameter: Daylight Savings Start Day. (Password level: 1.) Allowed values: Sunday, Monday, Tuesday, Wednesday, Thursday, Friday, Saturday. (Default: Sunday.)
Hr	Use to set the hour of the day when daylight savings time starts. Parameter: Daylight Savings Start Hour. (Password level: 1.) Allowed values: 0~23. (Default: 2.)
End	
Month	Use to set the month when daylight savings time ends. Parameter: Daylight Savings End Month. (Password level: 1.) Allowed values: 1~12. (Default: 10.)
Week	Use to set the week of the month when daylight savings time ends. Parameter: Daylight Savings End Week. (Password level: 1.) Allowed values: First Week, Second Week, Third Week, Fourth Week, Last Week. (Default: Last Week.)

NAME	DESCRIPTION
Day	Use to set the day of the week when daylight savings time ends. Parameter: Daylight Savings End Day. (Password level: 1.) Allowed values: Sunday, Monday, Tuesday, Wednesday, Thursday, Friday, Saturday. (Default: Sunday.)
Hr	Use to set the hour of the day when daylight savings time ends. Parameter: Daylight Savings End Hour. (Password level: 1.) Allowed values: 0~23. (Default: 2.)

Modbus Setup (Setup/MODBUS)

Note: See <http://www.modbus.org> for more information about Modbus.

Connect the PCC via Modbus RTU (Remote Terminal Unit) protocol on a two-wire RS-485 master/slave bus. In this arrangement, the external device is the master, and the PCC is the slave.

The external device can use the Modbus connection to perform these tasks on the PCC.

- Monitor basic read-only parameters
- Write any parameter that is not considered a factory-setup or one-time-use parameter.
- Start and stop the genset.

The external device cannot access any information in tables.

The external device can read 1–40 contiguous registers, write 1–40 contiguous registers, or read diagnostic counters.

The PCC uses eight data bits and one stop bit in Modbus connections. You can set up these parameters for Modbus connections.

- *Modbus Node Address:* This depends on the Modbus network to which the PCC is connected.
- *Modbus Baud Rate:* 2400 bps, 4800 bps, 9600 bps, 19200 bps, or 38400 bps.
- *Modbus Parity:* none, odd, or even.

Each label is described in the following table.

TABLE 3-11. MODBUS SETUP (SETUP/MODBUS)

NAME	DESCRIPTION
Node Address	Sets the modbus address for this node Parameter: Modbus Node Address. (Password level: 1.) Allowed values: 1~247. (Default: 2.)
Baud Rate	Sets the modbus baud rate. Parameter: Modbus Baud Rate. (Password level: 1.) Allowed values: 2400 Baud, 4800 Baud, 9600 Baud, 19200 Baud, 38400 Baud. (Default: 9600.)
Parity	Sets the modbus parity for this node Parameter: Modbus Parity. (Password level: 1.) Allowed values: Even, Odd, None. (Default: None.)
Lost Response	When set to Reset Commands will reset the modbus control logicals to an inactive state when Modbus communications are lost Parameter: Modbus Communications Lost Response Method. (Password level: 1.) Allowed values: Do Nothing, Reset Commands. (Default: Do Nothing.)
Bus Mess Count	Modbus bus message count Parameter: Modbus Bus Message Count.
Slave Mess Count	Modbus slave message count Parameter: Modbus Slave Message Count.
No Resp Count	Modbus no response count Parameter: Modbus No Response Count.
CRC Error Count	Modbus CRC errors count Parameter: Modbus CRC Errors Count.
Exception Count	Modbus exception count Parameter: Modbus Exception Count.

NAME	DESCRIPTION
Clr Counters	Resets all modbus counters Parameter: Modbus Clear Counters. (Password level: 1.) Allowed values: Do Nothing, Clear Counters. (Default: Do Nothing.)
Fail Time Delay	Time delay before the control activates the modbus failure fault after the master is sensed as no longer present. Parameter: Modbus Failure Time Delay. (Password level: 1.) Allowed values: 0~10 seconds. (Default: 4 seconds.)
Reset Cmds	Resets all modbus volatile commands Parameter: Reset Modbus Commands. (Password level: 1.) Allowed values: Inactive, Active. (Default: Inactive.)

Adjust Droop (Setup/Adjust/Droop)

Each label is described in the following table.

TABLE 3-12. ADJUST DROOP (SETUP/ADJUST/DROOP)

NAME	DESCRIPTION
Average Voltage	Genset Line to Line average voltage Parameter: Genset LL Average Voltage.
Volt Adjust	A trim that allows the user to add/subtract an offset to the nominal voltage when calculating the voltage setpoint Parameter: Voltage Adjust. Allowed values: -5~5 %. (Default: 0 %.)
Frequency	The frequency scaled version of the final speed reference Parameter: Final Frequency Reference. Allowed values: 0~100 Hz.
Frequency Adj	A method of adding in a frequency offset to the base frequency subject to high and low limit calibrations Parameter: Frequency Adjust. Allowed values: -6~6 Hz. (Default: 0 Hz.)
Rated/Idle Sw	Volatile to store PCCnet device generated Rated/Idle Switch commands. Parameter: Rated/Idle Switch (PCCnet). Allowed values: Rated, Idle. (Default: Rated.)
Key Override En	Activates the "Keyswitch Override Command" for this fault. Parameter: Keyswitch Override Enable. (Password level: 1.) Allowed values: Disabled, Enabled. (Default: Disabled.)
Key Override	Allow activation or deactivation of the override command for this fault. Parameter: Keyswitch Override Cmd. Allowed values: Inactive, Active. (Default: Inactive.)
Exer Switch	Temporary parameter to store PCCnet device generated Exercise Switch command. Parameter: Exercise Switch (PCCnet). Allowed values: Inactive, Active. (Default: Inactive.)
AVR Gain	A trim that allows the user to modify the overall gains of the AVR. Parameter: AVR Gain Adjust Trim. Allowed values: 0.05~10. (Default: 1.)
Governor Gain	A trim that allows the user to modify the overall gain of the governor Parameter: Governor Gain Adjust. Allowed values: 0.05~10. (Default: 1.)

Calibration Setup (Setup/Calibration)

Each label is described in the following table.

TABLE 3-13. CALIBRATION (SETUP/CALIBRATION)

NAME	DESCRIPTION
Genset Voltage Adjust	
L12 Voltage	Genset L12 voltage adjust trim Parameter: Genset L12 Voltage Adjust. (Password level: 1.) Allowed values: 90~110 %. (Default: 100 %.)

NAME	DESCRIPTION
L23 Voltage	Genset L23 voltage adjust trim Parameter: Genset L23 Voltage Adjust. (Password level: 1.) Allowed values: 90~110 %. (Default: 100 %.)
L31 Voltage	Genset L31 voltage adjust trim Parameter: Genset L31 Voltage Adjust. (Password level: 1.) Allowed values: 90~110 %. (Default: 100 %.)
Genset Single Ph Voltage Adjust	
L1N Voltage	Genset Single Phase L1N voltage adjust trim. Parameter: Genset Single Phase L1N Voltage Adjust. (Password level: 1.) Allowed values: 90~110 %. (Default: 100 %.)
L2N Voltage	Genset Single Phase L2N voltage adjust trim. Parameter: Genset Single Phase L2N Voltage Adjust. (Password level: 1.) Allowed values: 90~110 %. (Default: 100 %.)
Genset Current	
L1 L2 L3	Alternator terminals.
Control(Amps)	Monitors the genset L1 current value. Parameter: Genset L1 Current. Genset L2 current Parameter: Genset L2 Current. Genset L3 current Parameter: Genset L3 Current.
Adjust(%)	Genset L1 current adjust trim in percentage. Parameter: Genset L1 Current Adjust. (Password level: 1.) Allowed values: 90~110 %. (Default: 100 %.) Genset L2 current adjust trim Parameter: Genset L2 Current Adjust. (Password level: 1.) Allowed values: 90~110 %. (Default: 100 %.) Genset L3 current adjust trim Parameter: Genset L3 Current Adjust. (Password level: 1.) Allowed values: 90~110 %. (Default: 100 %.)

Configurable I/O (Config I/O)

Configurable Inputs

Each configurable input has a default function. These default functions are identified in Table 3-14.

TABLE 3-14. DEFAULT FUNCTIONS FOR CONFIGURABLE INPUTS

INPUT	DEFAULT FUNCTION
1	Event/fault Input
2	Event/fault Input
5	Low Coolant Level Switch
6	Low Fuel Level Switch
10	Remote Fault Reset Switch
11	Start Type
12	Rupture Basin Switch
13	Event/fault Input
14	Event/fault Input

Default functions are available only on the indicated inputs. For example, Configurable Input #5 can be a Low Coolant Level Switch but not an event/fault Input.

Each configurable input can also be mapped to one of these functions, instead of their default function.

- Low Fuel in Day Tank Switch
- Low Coolant Switch #2
- High Alt Temperature Switch
- Ground Fault Switch
- Exercise Switch
- Battle Short Switch
- Battery Charger Failed Switch
- Low Engine Temperature Switch
- Speed Droop Enable Switch
- Voltage Droop Enable Switch

Note: Currently, Speed Droop Enable Switch and Voltage Droop Enable Switch are not available, but they appear in the Operator Panel.

You can only map one configurable input to each of these functions. For example, there cannot be two Battle Short Switches.

You can also set up a configurable input to do nothing at all.

You can specify the function of each configurable input if this ability is not locked. For example, if *Configurable Input #1 Factory Lock* is Not Locked, use *Configurable Input #1 Input Function Pointer* to specify the function of Configurable Input #1. If *Configurable Input #1 Factory Lock* is Locked, you can still look at *Configurable Input #1 Input Function Pointer* to see what the current function of Configurable Input #1 is.

You can specify the active state for each configurable input. For example, *Configurable Input #1 Active State Selection* specifies the active state for Configurable Input #1.

Event/fault Input (Default Function for Configurable Inputs #1, #2, #13, and #14)

Table 3-15 identifies the configurable inputs and the event/fault codes the PCC generates when a configurable input becomes active.

TABLE 3-15. CONFIGURABLE INPUT EVENT/FAULT CODES

INPUT	EVENT/FAULT CODE
1	1573
2	1312
13	1317
14	1318

Note: *Configurable Input #1 Fault Response* has no effect unless the configurable input is mapped to its default function.

By default, configurable inputs generate events, though this may be changed at the factory.

You can specify the text that is displayed when the corresponding event/fault input is active. For example, use *Configurable Input #1 Fault Text* to specify the text for event/fault code 1573. The parameters for other configurable inputs are similar.

Low Coolant Level Switch (Default Function for Configurable Input #5)

The PCC generates one of the faults in Table 3-16 when the switch becomes active.

TABLE 3-16. LOW COOLANT LEVEL FAULTS

LCL DETECTION RESPONSE	FAULT
Shutdown	Shutdown fault 235
Warning	Warning fault 197
None	No fault

Low Fuel Level Switch (Default Function for Configurable Input #6)

The PCC generates warning fault 1441 (Low Fuel Level) after the switch is active for *Low Fuel Set/Clear Time*.

Remote Fault Reset Switch (Default Function for Configurable Input #10)

The PCC may be connected to a device that can generate a fault reset signal (page 5-3).

Start Type (Default Function for Configurable Input #11)

The PCC may be connected to a device that can generate a start type signal (page 2-9).

Rupture Basin Switch (Default Function for Configurable Input #12)

The PCC generates warning fault 2945 (Rupture Basin Switch) after this switch is active for *Rupture Basin Time*.

Low Fuel in Day Tank Switch

The PCC generates warning fault 1439 (Low Day Tank Fuel Sw) after the switch is active for *Low Fuel in Day Tank Time*.

Low Coolant Switch #2

The PCC generates warning fault 2977 (Low Coolant Level 2 Sw) as soon as the switch becomes active.

High Alt Temperature Switch

The PCC generates warning fault 2979 (High Alternator Temp Sw) after the switch is active for *High Alternator Temperature Switch Time*.

Ground Fault Switch

The PCC generates warning fault 2938 (Ground Fault Switch) when the ground fault relay becomes active.

Exercise Switch

The PCC may be connected to a device that can generate an exercise signal (page 2-8).

Battle Short Switch

The PCC may be connected to a device that puts the PCC in Battle Short mode (page 5-3).

Battery Charger Failed Switch

The PCC generates warning fault 2993 (Battery Charger Sw Fail) when the battery charger stops working properly.

Low Engine Temperature Switch

The PCC generates warning fault 1435 (Low Coolant Temperature) when the switch becomes active.

Speed Droop Enable Switch

This is reserved for future use.

Voltage Droop Enable Switch

This is reserved for future use.

Configurable Outputs

Each configurable output has a default function. These default functions are identified in Table 3-17.

TABLE 3-17. DEFAULT FUNCTIONS FOR CONFIGURABLE OUTPUTS

OUTPUT	DEFAULT FUNCTION
1	Event/fault Output
2	Event/fault Output
3	Event/fault Output
4	Event/fault Output
5	Ready To Load
6	Oil Priming Pump
7	Local Status
10	Delayed Off
11	Load Dump

Default functions are available only on the indicated outputs. For example, Configurable Output #5 can generate a Ready To Load signal but not a Delayed Off signal.

In addition, each configurable output can be mapped to one of these functions instead.

- Common Warning (event code 1540)
- Common Shutdown (event code 1541)
- Rated to Idle Transition Event (event code 1122)

- *Fault Code Function #1*
- *Fault Code Function #2*
- *Fault Code Function #3*
- *Fault Code Function #4*
- *Fault Code Function #5*

You can map each Fault Code Function parameter to a specific event/fault code (page 5-4).

You can only map one configurable output to each of these functions. For example, there cannot be two Common Shutdown outputs.

You can also set up a configurable output to do nothing at all.

In addition, you can specify the function of each configurable output if this ability is not locked. For example, use *Configurable Output #1 Output Function Pointer* to specify the function of Configurable Output #1 if *Configurable Output #1 Factory Lock* is Not Locked. If *Configurable Output #1 Factory Lock* is Locked, you can still look at *Configurable Output #1 Output Function Pointer* to see what the current function of Configurable Output #1 is.

You can specify whether or not the PCC should invert the output signal. For example, *Configurable Output #1 Invert Bypass* is set to Not Bypassed if Configurable Output #1 should be inverted.

Event/fault Outputs (Default Function for Configurable Outputs #1, #2, #3, and #4)

Use one of these parameters to map a configurable output to a specific event/fault code (page 5-4).

- *Configurable Output #1 Event Code*
- *Configurable Output #2 Event Code*
- *Configurable Output #3 Event Code*
- *Configurable Output #4 Event Code*

The configurable output follows the status of the event. If the event is active, the configurable output is active. If the event is inactive, the configurable output is inactive.

Ready To Load (Default Function for Configurable Output #5)

The PCC may notify a device when event 1465 (Ready to Load) (page 3-30) is active.

Oil Priming Pump (Default Function for Configurable Output #6)

The PCC may be connected to the oil-priming pump to prelude the engine. This reduces wear and dam-

age to moving parts in the engine after long periods of inactivity.

See **Sequences of Operation** (page 2-11) for more information about the behavior of this output.

Local Status (Default Function for Configurable Output #7)

This is reserved for future use.

Delayed Off (Default Function for Configurable Output #10)

The PCC may notify a device while the genset is running and for *Delayed Off FSO Relay Time* after the genset stop running.

Load Dump (Default Function for Configurable Output #11)

The PCC may notify a device when warning fault 1464 (Load Dump Fault) (page 3-20) is active.

Each label is described in the following table.

TABLE 3-18. CONFIGURABLE I/O

NAME	DESCRIPTION
Config Input #1	
Active	Trim which allows Input #1 to be inverted logically in the software. Parameter: Configurable Input #1 Active State Selection. (Password level: 1.) Allowed values: Active Closed, Active Open. (Default: Active Closed.)
Function	Configurable Input #1 Input function pointer. Selects discrete input fault/event for this input. Parameter: Configurable Input #1 Input Function Pointer_. (Password level: 1.) Allowed values: Default, Do Nothing, Low Fuel in Day Tank Switch, Low Coolant Switch #2, High Alt Temperature Switch, Ground Fault Switch, Exercise Switch, Battle Short Switch, Battery Charger Failed Switch, Low Engine Temperature Switch, Speed Droop Enable Switch, Voltage Droop Enable Switch. (Default: Default.)
Customer Fault 1 Text	Trim to define the 16 character string for use by the Operator panel when this fault becomes active. Parameter: Configurable Input #1 Fault Text. (Password level: 1.)
Config Input #2	
Active	Trim which allows Input #2 to be inverted logically in the software. Parameter: Configurable Input #2 Active State Selection. (Password level: 1.) Allowed values: Active Closed, Active Open. (Default: Active Closed.)
Function	Configurable Input #2 Input function pointer. Selects discrete input fault/event for this input. Parameter: Configurable Input #2 Input Function Pointer_. (Password level: 1.) Allowed values: Default, Do Nothing, Low Fuel in Day Tank Switch, Low Coolant Switch #2, High Alt Temperature Switch, Ground Fault Switch, Exercise Switch, Battle Short Switch, Battery Charger Failed Switch, Low Engine Temperature Switch, Speed Droop Enable Switch, Voltage Droop Enable Switch. (Default: Default.)
Customer Fault 2 Text	Trim to define the 16 character string for use by the Operator panel when this fault becomes active. Parameter: Configurable Input #2 Fault Text. (Password level: 1.)
Config Input #13	
Active	Trim which allows Input #13 to be inverted logically in the software. Parameter: Configurable Input #13 Active State Selection. (Password level: 1.) Allowed values: Active Closed, Active Open. (Default: Active Closed.)
Function	Configurable Input #13 Input function pointer. Selects discrete input fault/event for this input. Parameter: Configurable Input #13 Input Function Pointer_. (Password level: 1.) Allowed values: Default, Do Nothing, Low Fuel in Day Tank Switch, Low Coolant Switch #2, High Alt Temperature Switch, Ground Fault Switch, Exercise Switch, Battle Short Switch, Battery Charger Failed Switch, Low Engine Temperature Switch, Speed Droop Enable Switch, Voltage Droop Enable Switch. (Default: Default.)

NAME	DESCRIPTION
Customer Fault 3 Text	Trim to define the 16 character string for use by the Operator panel when this fault becomes active. Parameter: Configurable Input #13 Fault Text. (Password level: 1.)
Config Input #14	
Active	Trim which allows Input #14 to be inverted logically in the software. Parameter: Configurable Input #14 Active State Selection. (Password level: 1.) Allowed values: Active Closed, Active Open. (Default: Active Closed.)
Function	Configurable Input #14 Input function pointer. Selects discrete input fault/event for this input. Parameter: Configurable Input #14 Input Function Pointer_. (Password level: 1.) Allowed values: Default, Do Nothing, Low Fuel in Day Tank Switch, Low Coolant Switch #2, High Alt Temperature Switch, Ground Fault Switch, Exercise Switch, Battle Short Switch, Battery Charger Failed Switch, Low Engine Temperature Switch, Speed Droop Enable Switch, Voltage Droop Enable Switch. (Default: Default.)
Customer Fault 4 text	Trim to define the 16 character string for use by the Operator panel when this fault becomes active. Parameter: Configurable Input #14 Fault Text. (Password level: 1.)
Config Input #5	
Active	Coolant Level input software logic state inversion bypass control Parameter: Coolant Level/Configurable Input #5 Active State Selection. (Password level: 1.) Allowed values: Active Closed, Active Open. (Default: Active Closed.)
Function	Coolant Level Input function pointer. Feeds input signal to alternate function input if value not set to default Parameter: Coolant Level/Configurable Input #5 Function Pointer_. (Password level: 1.) Allowed values: Default, Do Nothing, Low Fuel in Day Tank Switch, Low Coolant Switch #2, High Alt Temperature Switch, Ground Fault Switch, Exercise Switch, Battle Short Switch, Battery Charger Failed Switch, Low Engine Temperature Switch, Speed Droop Enable Switch, Voltage Droop Enable Switch. (Default: Default.)
Config Input #6	
Active	Low Fuel input software logic state inversion bypass control Parameter: Low Fuel/Configurable Input #6 Active State Selection. (Password level: 1.) Allowed values: Active Closed, Active Open. (Default: Active Closed.)
Function	Low Fuel Input function pointer. Feeds input signal to alternate function input if value not set to default Parameter: Low Fuel/Configurable Input #6 Function Pointer_. (Password level: 1.) Allowed values: Default, Do Nothing, Low Fuel in Day Tank Switch, Low Coolant Switch #2, High Alt Temperature Switch, Ground Fault Switch, Exercise Switch, Battle Short Switch, Battery Charger Failed Switch, Low Engine Temperature Switch, Speed Droop Enable Switch, Voltage Droop Enable Switch. (Default: Default.)
Config Input #10	
Active	Fault Reset input software logic state inversion bypass control. Parameter: Fault Reset/Configurable Input #10 Active State Selection. (Password level: 1.) Allowed values: Active Closed, Active Open. (Default: Active Closed.)

NAME	DESCRIPTION
Function	Fault Reset Input function pointer. Feeds input signal to alternate function input if value not set to default. Parameter: Fault Reset/Configurable Input #10 Function Pointer_. (Password level: 1.) Allowed values: Default, Do Nothing, Low Fuel in Day Tank Switch, Low Coolant Switch #2, High Alt Temperature Switch, Ground Fault Switch, Exercise Switch, Battle Short Switch, Battery Charger Failed Switch, Low Engine Temperature Switch, Speed Droop Enable Switch, Voltage Droop Enable Switch. (Default: Default.)
Config Input #11	
Active	Start Type input software logic state inversion bypass control Parameter: Start Type/Configurable Input #11 Active State Selection. (Password level: 1.) Allowed values: Active Closed, Active Open. (Default: Active Closed.)
Function	Start Type Input function pointer. Feeds input signal to alternate function input if value not set to default Parameter: Start Type/Configurable Input #11 Function Pointer_. (Password level: 1.) Allowed values: Default, Do Nothing, Low Fuel in Day Tank Switch, Low Coolant Switch #2, High Alt Temperature Switch, Ground Fault Switch, Exercise Switch, Battle Short Switch, Battery Charger Failed Switch, Low Engine Temperature Switch, Speed Droop Enable Switch, Voltage Droop Enable Switch. (Default: Default.)
Config Input #12	
Active	Rupture Basin input software logic state inversion bypass control Parameter: Rupture Basin/Configurable Input #12 Active State Selection. (Password level: 1.) Allowed values: Active Closed, Active Open. (Default: Active Closed.)
Function	Rupture Basin Input function pointer. Feeds input signal to alternate function input if value not set to default Parameter: Rupture Basin/Configurable Input #12 Function Pointer_. (Password level: 1.) Allowed values: Default, Do Nothing, Low Fuel in Day Tank Switch, Low Coolant Switch #2, High Alt Temperature Switch, Ground Fault Switch, Exercise Switch, Battle Short Switch, Battery Charger Failed Switch, Low Engine Temperature Switch, Speed Droop Enable Switch, Voltage Droop Enable Switch. (Default: Default.)
Config Output #1	
Event Code	The event code for this output. Parameter: Configurable Output #1 Event Code. (Password level: 1.) Allowed values: 0~65530. (Default: 1540.)
Function	Points to the fault/event that controls the output. Parameter: Configurable Output #1 Output Function Pointer_. (Password level: 1.) Allowed values: Default, Do Nothing, Common Warning, Common Shutdown, Rated to Idle Transition Event, Fault Code Function #1, Fault Code Function #2, Fault Code Function #3, Fault Code Function #4, Fault Code Function #5. (Default: Default.)
Inv Bypass	Controls whether the output function is inverted or not. Bypassed = function not inverted Parameter: Configurable Output #1 Invert Bypass. (Password level: 1.) Allowed values: Not Bypassed, Bypassed. (Default: Bypassed.)
Config Output #2	
Event Code	The event code for this output. Parameter: Configurable Output #2 Event Code. (Password level: 1.) Allowed values: 0~65530. (Default: 1541.)

NAME	DESCRIPTION
Function	Points to the fault/event that controls the output. Parameter: Configurable Output #2 Output Function Pointer_. (Password level: 1.) Allowed values: Default, Do Nothing, Common Warning, Common Shutdown, Rated to Idle Transition Event, Fault Code Function #1, Fault Code Function #2, Fault Code Function #3, Fault Code Function #4, Fault Code Function #5. (Default: Default.)
Inv Bypass	Controls whether the output function is inverted or not. Bypassed = function not inverted Parameter: Configurable Output #2 Invert Bypass. (Password level: 1.) Allowed values: Not Bypassed, Bypassed. (Default: Bypassed.)
Config Output #3	
Event Code	The event code for this output. Parameter: Configurable Output #3 Event Code. (Password level: 1.) Allowed values: 0~65530. (Default: 1463.)
Function	Points to the fault/event that controls the output. Parameter: Configurable Output #3 Output Function Pointer_. (Password level: 1.) Allowed values: Default, Do Nothing, Common Warning, Common Shutdown, Rated to Idle Transition Event, Fault Code Function #1, Fault Code Function #2, Fault Code Function #3, Fault Code Function #4, Fault Code Function #5. (Default: Default.)
Inv Bypass	Controls whether the output function is inverted or not. Bypassed = function not inverted Parameter: Configurable Output #3 Invert Bypass. (Password level: 1.) Allowed values: Not Bypassed, Bypassed. (Default: Bypassed.)
Config Output #4	
Event Code	The event code for this output. Parameter: Configurable Output #4 Event Code. (Password level: 1.) Allowed values: 0~65530. (Default: 1465.)
Function	Points to the fault/event that controls the output. Parameter: Configurable Output #4 Output Function Pointer_. (Password level: 1.) Allowed values: Default, Do Nothing, Common Warning, Common Shutdown, Rated to Idle Transition Event, Fault Code Function #1, Fault Code Function #2, Fault Code Function #3, Fault Code Function #4, Fault Code Function #5. (Default: Default.)
Inv Bypass	Controls whether the output function is inverted or not. Bypassed = function not inverted Parameter: Configurable Output #4 Invert Bypass. (Password level: 1.) Allowed values: Not Bypassed, Bypassed. (Default: Bypassed.)
Config Output (#5/#6)	
Function (5)	Points to the function that controls the output Parameter: Ready To Load /Configurable Output #5 Output Function Pointer_. (Password level: 1.) Allowed values: Default, Do Nothing, Common Warning, Common Shutdown, Rated to Idle Transition Event, Fault Code Function #1, Fault Code Function #2, Fault Code Function #3, Fault Code Function #4, Fault Code Function #5. (Default: Default.)
Inv Bypass (5)	Controls whether the output function is inverted or not. Bypassed = function not inverted Parameter: Ready To Load /Configurable Output #5 Invert Bypass. (Password level: 1.) Allowed values: Not Bypassed, Bypassed. (Default: Bypassed.)

NAME	DESCRIPTION
Function (6)	Points to the function that controls the output Parameter: Oil Priming Pump / Configurable Output #6 Output Function Pointer_ . (Password level: 1.) Allowed values: Default, Do Nothing, Common Warning, Common Shutdown, Rated to Idle Transition Event, Fault Code Function #1, Fault Code Function #2, Fault Code Function #3, Fault Code Function #4, Fault Code Function #5. (Default: Default.)
Inv Bypass (6)	Controls whether the output function is inverted or not. If bypassed, the function is not inverted Parameter: Oil Priming Pump / Configurable Output #6 Invert Bypass. (Password level: 1.) Allowed values: Not Bypassed, Bypassed. (Default: Bypassed.)
Config Output (#7/#8)	
Function (7)	Points to the function that controls the output Parameter: Local Status / Configurable Output #7 Output Function Pointer_ . (Password level: 1.) Allowed values: Default, Do Nothing, Common Warning, Common Shutdown, Rated to Idle Transition Event, Fault Code Function #1, Fault Code Function #2, Fault Code Function #3, Fault Code Function #4, Fault Code Function #5. (Default: Default.)
Inv Bypass (7)	Controls whether the output function is inverted or not. Bypassed = function not inverted Parameter: Local Status / Configurable Output #7 Invert Bypass. (Password level: 1.) Allowed values: Not Bypassed, Bypassed. (Default: Bypassed.)
Function (8)	Points to the function that controls the output Parameter: Glow Plug / Configurable Output #8 Output Function Pointer. (Password level: 1.) Allowed values: Default, Do Nothing, Common Warning, Common Shutdown, Rated to Idle Transition Event, Fault Code Function #1, Fault Code Function #2, Fault Code Function #3, Fault Code Function #4, Fault Code Function #5. (Default: Default.)
Inv Bypass (8)	Controls whether the output function is inverted or not. Bypassed = function not inverted Parameter: Glow Plug / Configurable Output #8 Invert Bypass. (Password level: 1.) Allowed values: Not Bypassed, Bypassed. (Default: Bypassed.)
Config Output (#10/#11)	
Function (10)	Points to the function that controls the output Parameter: Delayed Off / Configurable Output #10 Output Function Pointer_ . (Password level: 1.) Allowed values: Default, Do Nothing, Common Warning, Common Shutdown, Rated to Idle Transition Event, Fault Code Function #1, Fault Code Function #2, Fault Code Function #3, Fault Code Function #4, Fault Code Function #5. (Default: Default.)
Inv Bypass (10)	Controls whether the output function is inverted or not. Bypassed = function not inverted Parameter: Delayed Off / Configurable Output #10 Invert Bypass. (Password level: 1.) Allowed values: Not Bypassed, Bypassed. (Default: Bypassed.)
Function (11)	Points to the function that controls the output Parameter: Load Dump / Configurable Output #11 Output Function Pointer_ . (Password level: 1.) Allowed values: Default, Do Nothing, Common Warning, Common Shutdown, Rated to Idle Transition Event, Fault Code Function #1, Fault Code Function #2, Fault Code Function #3, Fault Code Function #4, Fault Code Function #5. (Default: Default.)

NAME	DESCRIPTION
Inv Bypass (11)	Controls whether the output function is inverted or not. Bypassed = function not inverted Parameter: Load Dump / Configurable Output #11 Invert Bypass. (Password level: 1.) Allowed values: Not Bypassed, Bypassed. (Default: Bypassed.)
Func #1 Fault	The fault/event code for this configurable function output. Parameter: Fault Code Function #1 Fault/Event Code. (Password level: 1.) Allowed values: 0~65530. (Default: 0.)
Func #2 Fault	The fault/event code for this configurable function output. Parameter: Fault Code Function #2 Fault/Event Code. (Password level: 1.) Allowed values: 0~65530. (Default: 0.)
Func #3 Fault	The fault/event code for this configurable function output. Parameter: Fault Code Function #3 Fault/Event Code. (Password level: 1.) Allowed values: 0~65530. (Default: 0.)
Func #4 Fault	The fault/event code for this configurable function output. Parameter: Fault Code Function #4 Fault/Event Code. (Password level: 1.) Allowed values: 0~65530. (Default: 0.)
Func #5 Fault	The fault/event code for this configurable function output. Parameter: Fault Code Function #5 Fault/Event Code. (Password level: 1.) Allowed values: 0~65530. (Default: 0.)

Genset Setup (Setup/Genset)

V/Hz Curve

Some non-linear loads demand high current when they start up or when they take on a large block load. This demand can cause significant voltage drops and frequency dips. The PCC can reduce the voltage setpoint (page 2-16) proportionally with engine speed to reduce underspeed conditions or under-voltage conditions but not both.

Usually, the V/Hz curve is set up to optimize engine speed recovery under block loading. It may need to be adjusted in applications that have large non-linear loads. Some non-linear loads, such as motors and pumps, are more sensitive to underfrequency conditions. Other non-linear loads, such as fluorescent and incandescent lighting, are more sensitive to undervoltage conditions.

CAUTION *This feature is not intended to compensate for undersized gensets. Failure to follow this may affect genset operation and may cause damage to the genset or to equipment connected to the genset.*

This feature is active when AVR is enabled (**Sequences of Operation**, page 2-11).

This behavior is controlled by these parameters.

- Target frequency: This is the speed reference (page 2-16).

- *V/Hz Knee Frequency*: This is how far below the target frequency the PCC begins reducing the voltage setpoint.
- *V/Hz Rolloff Slope*: This specifies how quickly (V/Hz) the PCC reduces the voltage setpoint once the frequency drops below the knee frequency.

This behavior is illustrated in Figure 3-1.

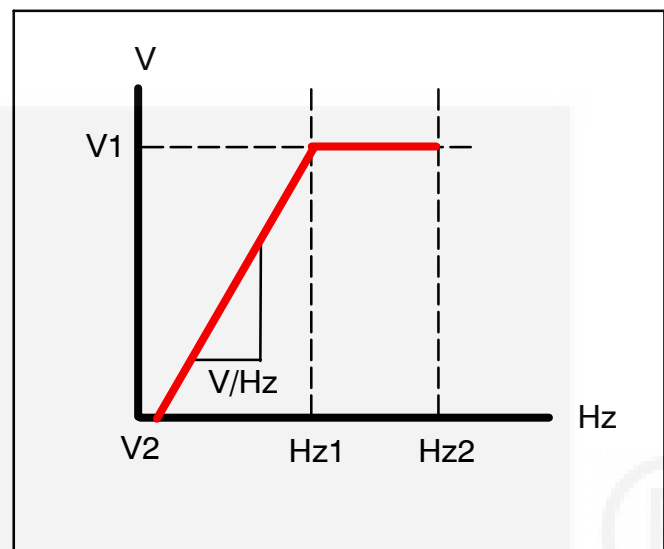

FIGURE 3-1. V/HZ CURVE

TABLE 3-19. V/HZ CURVE

LABEL	DESCRIPTION
Hz1	Speed reference – V/Hz Knee Frequency
Hz2	Speed reference
V1	Voltage setpoint (without the V/Hz curve adjustment)

V2	Voltage setpoint (with the V/Hz curve adjustment)
V/Hz	V/Hz Rolloff Slope

For example, a genset has these settings.

- *Genset Nominal Voltage* is 480 VAC, and the voltage setpoint is 100%, or 480 VAC, without the V/Hz curve adjustment.
- *Genset Frequency* is 60 Hz, and the speed reference is 3600 rpm.
- *V/Hz Knee Frequency* is 1.0 Hz.
- *V/Hz Rolloff Slope* is 2.2 %V/Hz.

Suppose the actual genset frequency is 56.5 Hz. This is 3.5 Hz (60 Hz – 56.5 Hz) below the speed reference. The PCC reduces the voltage setpoint by $(3.5 \text{ Hz} - 1.0 \text{ Hz}) * 2.2 \% \text{V/Hz}$. The reduction is 5.5%, or 26.4 VAC ($5.5\% * 480 \text{ VAC}$). The voltage setpoint is 454 VAC (480 VAC – 26 VAC) with the V/Hz curve adjustment.

Exercise Scheduler

The PCC can run the genset regularly to prevent the genset from being inactive for long periods of time.

The PCC generates an exercise signal (page 2-8) when these conditions are met.

- The PCC is in Auto mode (page 2-8).
- The PCC is not in power-down mode (page 2-10).
- There are no active shutdown faults.
- *Exercise Scheduler Enable* is set to Enable.
- A scheduler program is beginning.
- There are no scheduled exceptions.

If the genset is running, this signal has no effect unless the remote start signal (page 2-9) becomes inactive. Then, the exercise signal keeps the genset running.

If the PCC is unable to start the genset for any reason, the scheduler program is skipped, even if the PCC later becomes able to start.

The PCC removes the exercise signal when the scheduler program finishes.

Scheduler Programs

You can set up 12 scheduler programs. For each program, specify the day of the week and the time the PCC starts the genset, how long the PCC runs the genset, and how often the program repeats.

- *Scheduler Program Enable*
- *Scheduler Program Start Day*: Sunday, Monday, ..., Saturday
- *Scheduler Program Start Hour*: 0–23
- *Scheduler Program Start Minute*: 0–59
- *Scheduler Program Duration Hours*: 0–23
- *Scheduler Program Duration Minutes*: 0–59
- *Scheduler Program Repeat Interval*: Once, every 1–5 weeks, first/second/third/fourth/last week of month
- *Scheduler Program Run Mode*: The PCC can run the genset with or without a load.

Scheduler programs follow these guidelines.

1. If two or more scheduler programs begin at the same time, the PCC runs the scheduler program with the lowest number and ignores the other scheduler programs, even after the first scheduler program ends.
2. If one scheduler program begins before another scheduled program ends, the PCC ignores the second program, even after the first scheduler program ends.
3. If the PCC loses power while a scheduler program is running, the PCC does not restart the scheduler program when power returns.

Scheduler Exceptions

You can also set up 6 scheduler exceptions. Scheduler exceptions prevent scheduler programs from running during specific intervals, such as holidays.

- *Scheduler Exception Enable*
- *Scheduler Exception Month*: 1–12
- *Scheduler Exception Date*: 1–31
- *Scheduler Exception Hour*: 0–23
- *Scheduler Exception Minute*: 0–59
- *Scheduler Exception Duration Days*: 0–44
- *Scheduler Exception Duration Hours*: 0–23
- *Scheduler Exception Duration Minutes*: 0–59

- *Scheduler Exceptions Repeat Interval*: One-time only or annual.

Scheduler programs and scheduler exceptions follow these guidelines.

1. The PCC ignores scheduler programs that start during scheduler exceptions.
2. If a scheduler program and a scheduler exception begin at the same time, the PCC ignores the scheduler program.
3. If two or more scheduler exceptions begin at the same time, the PCC runs the scheduler exception with the lowest number and ignores the other scheduler exceptions, even after the first scheduler exception ends.
4. If a scheduler exception begins before a scheduler program ends, the PCC ignores the scheduler exception, even after the scheduler program ends.
5. If one scheduler exception begins before another scheduler exception ends, the PCC ignores the second scheduler exception, even after the first scheduler exception ends.

6. If the PCC loses power while a scheduler exception is running, the PCC does not restart the scheduler exception when power returns.

Load Dump

Warning fault 1464 (Load Dump Fault) is active when one of these conditions applies.

- A derate event (page 5-3) is active.
- A delayed shutdown (page 5-4) is active.
- One of these conditions applies, based on *Load Dump Activation Method*.
 - The genset is overloaded by *Load Dump Overload Threshold for Load Dump Overload Set Time*.
 - The genset is running underfrequency by *Load Dump Underfrequency Offset for Load Dump Underfrequency Set Time*, and Ready to Load (page 1-6) is active. The Ready to Load output does not have to be used.

Each label is described in the following table.

TABLE 3-20. GENSET SETUP (SETUP/GENSET)

NAME	DESCRIPTION
Setup Mode	Volatile to allow entry into Setup Mode Parameter: Setup Mode Enable.
Nom Voltage	Genset nominal line-line voltage Parameter: Genset Nominal Voltage. (Password level: 1.) Allowed values: 1~45000 Vac. (Default: 1 Vac.)
Wye/Delta	Delta or Wye for Genset connection Parameter: Genset Delta/Wye Connection. (Password level: 1.) Allowed values: Delta, Wye. (Default: Wye.)
Single/3 Ph	Setup mode interlocked. Genset's single phase/3 phase metering setup configuration. Parameter: Single/3 Phase Connection. (Password level: 1.) Allowed values: Single Phase, Three Phase. (Default: Three Phase.)
Rating	Selects genset's standby/prime/base application rating. Parameter: Application Rating Select. (Password level: 1.) Allowed values: Standby, Prime, Base. (Default: Standby.)
Freq Switch	Sets the genset nominal frequency. Parameter: Alternate Frequency Switch. (Password level: 1.) Allowed values: 50 Hz, 60 Hz. (Default: 60Hz.)
Idle Speed	Sets the speed at which the engine will idle subject to high and low limit calibrations. If ECM CAN Enable is Enable, this is controlled on the ECM. Parameter: Idle Speed. (Password level: 1.) Allowed values: 700~1100 rpm. (Default: 800 rpm.)
Src Name	Name for the genset source. Parameter: Genset Source Name. (Password level: 1.)
Site ID	name of site Parameter: Site ID. (Password level: 1.)
PwrDn Enable	Trim to enable sleep mode Parameter: Power Down Mode Enable. (Password level: 1.) Allowed values: Disable, Enable. (Default: Enable.)

NAME	DESCRIPTION
PwrDn Delay	Timer setting for the Power Down delay feature Parameter: Power Down Mode Time Delay. (Password level: 1.) Allowed values: 0~600 seconds. (Default: 0 seconds.)
Auto Sleep En	Trim that determines if the control will Stay Awake in Auto mode or Fall asleep in Auto mode. Parameter: Auto Sleep Enable. (Password level: 1.) Allowed values: Awake in Auto, Sleep in Auto.
AVR Gain	A trim that allows the user to modify the overall gains of the AVR. Parameter: AVR Gain Adjust Trim. (Password level: 1.) Allowed values: 0.05~10. (Default: 1.)
Gov Gain	A trim that allows the user to modify the overall gain of the governor Parameter: Governor Gain Adjust. (Password level: 1.) Allowed values: 0.05~10. (Default: 1.)
AVR Ramp Time	The time period over which the voltage setpoint command should rise from 0% to the target voltage Parameter: Voltage Ramp Time. (Password level: 2.) Allowed values: 0~5 seconds. (Default: 1.25 seconds.)
AVR Damp 50	Increases or decreases the output response of the AVR. A lower input value will increase the transient response. A higher value will decrease the transient response. Parameter: AVR Damping Effect (50 Hz). (Password level: 2.) Allowed values: 0~99.99. (Default: 78.)
AVR Damp 60	Increases or decreases the output response of the AVR. A lower input value will increase the transient response. A higher value will decrease the transient response. Parameter: AVR Damping Effect (60 Hz). (Password level: 2.) Allowed values: 0~99.99. (Default: 79.)
V/Hz Slope	The amount of voltage roll off when the frequency is below the knee frequency Parameter: V/Hz Rolloff Slope. (Password level: 1.) Allowed values: 0~10 % / Hz. (Default: 2.2 % / Hz.)
V/Hz Knee	The voltage will roll off (decrease) proportionally to the V/Hz setup, once the frequency drops below the set point in the V/Hz Knee Frequency. This allows the genset to recover faster when the frequency drops. Parameter: V/Hz Knee Frequency. (Password level: 1.) Allowed values: 0~10 Hz. (Default: 1 Hz.)
Cycle/Crank Sel	Selects whether to use continuous cranking or cycle cranking when attempting to start engine Parameter: Cycle / Cont Crank Select. (Password level: 1.) Allowed values: Cycle, Continuous. (Default: Cycle.)
Attempts	Sets the maximum number of times to engage the starter when attempting to start engine using the cycle cranking method Parameter: Crank Attempts. (Password level: 1.) Allowed values: 1~7. (Default: 3.)
Cont Crank	Sets the maximum amount of time to engage the starter when using the continuous cranking method Parameter: Continuous Crank Engage Time. (Password level: 1.) Allowed values: 40~100 seconds. (Default: 75 seconds.)
Cycle Crank	Sets the maximum amount of time to engage the starter during a single crank attempt when using the cycle cranking method Parameter: Cycle Crank Engage Time. (Password level: 1.) Allowed values: 2~20 seconds. (Default: 15 seconds.)
Rest Time	Sets the amount of time to wait between crank attempts Parameter: Cycle Crank Rest Time. (Password level: 1.) Allowed values: 7~40 seconds. (Default: 15 seconds.)
Disc Speed	Sets the engine speed at which the cranking algorithm disengages the starter Parameter: Starter Disconnect Speed. (Password level: 1.) Allowed values: 100~600 rpm. (Default: 475 rpm.)

NAME	DESCRIPTION
Start Delay	Sets the time to wait from receiving a valid remote start signal until starting the genset Parameter: Start Time Delay. (Password level: 1.) Allowed values: 0~300 seconds. (Default: 0 seconds.)
Stop Delay	Sets time to run at rated speed before going to cooldown at idle. Does not apply to manual runs Parameter: Time Delay to Stop. (Password level: 1.) Allowed values: 0~600 seconds. (Default: 0 seconds.)
Delay Off FSO	Time delay between when the Delayed Off Command turns off and Run Command turns off Parameter: Delayed Off FSO Relay Time. (Password level: 1.) Allowed values: 0~120 seconds. (Default: 0 seconds.)
Warmup Temp	Coolant temperature threshold to end idle warmup time Parameter: Idle Warmup Coolant Temp. (Password level: 1.) Allowed values: -40~300 degF. (Default: 100 degF.)
Warmup Time	Sets maximum idle warmup time. Warmup time may be less if coolant temperature exceeds threshold Parameter: Idle Warmup Time. (Password level: 1.) Allowed values: 0~3600 seconds. (Default: 0 seconds.)
Max Idle	Sets the fault time for the Too Long in Idle fault. Parameter: Max Idle Time. (Password level: 2.) Allowed values: 0~20 minutes. (Default: 10 minutes.)
Idle Rated Ramp	The time over which the speed reference is to ramp from idle speed to rated speed Parameter: Idle to Rated Ramp Time. (Password level: 1.) Allowed values: 0~30 seconds. (Default: 0 seconds.)
Rated Idle Dly	Sets the delay time for transitioning from Rated to Idle speed. 0 seconds = feature is disabled. Parameter: Rated to Idle Transition Delay. (Password level: 1.) Allowed values: 0~10 seconds. (Default: 0 seconds.)
Rated Idle Ramp	The time over which the speed reference is to ramp from rated speed to idle speed Parameter: Rated to Idle Ramp Time. (Password level: 1.) Allowed values: 0~30 seconds. (Default: 0 seconds.)
Rated Cooldn	Minimum time to spend at rated speed less than 10% load before normal shutdown is allowed Parameter: Rated Cooldown Time. (Password level: 1.) Allowed values: 0~600 seconds. (Default: 0 seconds.)
Idle Cooldown	Sets time to run at idle before shutting down genset on normal stops Parameter: Idle Cooldown Time. (Password level: 1.) Allowed values: 0~60 minutes. (Default: 10 minutes.)
Rupt Bas Time	Rupture Basin fault time delay Parameter: Rupture Basin Time. (Password level: 1.) Allowed values: 0~20 seconds. (Default: 2 seconds.)
Prelube	
Cycle Enable	Enables Or Disables the cyclic mode of prelube operation Parameter: Prelube Cycle Enable. (Password level: 1.) Allowed values: Disabled, Enabled. (Default: Disabled.)
Cycle Time	Sets the period of the Prelube Cycle Iteration Parameter: Prelube Cycle Time. (Password level: 1.) Allowed values: 1~1000 hours. (Default: 168 hours.)
Oil Prs Thld	The oil pressure value which when reached the prelube driver will turn off Parameter: Prelube Oil Pressure Threshold. (Password level: 1.) Allowed values: 0~10 psig. (Default: 3 psig.)
Timeout	Sets the maximum time for which the Prelube Driver will Remain ON Parameter: Prelube Timeout Period. (Password level: 1.) Allowed values: 0~30 seconds. (Default: 10 seconds.)
Load Dump	

NAME	DESCRIPTION
Activation	Enables the load dump output as a function of the overload and underfrequency conditions Parameter: Load Dump Activation Method. (Password level: 1.) Allowed values: Overload, Underfrequency, Overload or Underfrequency, Disabled. (Default: Overload or Overfreq.)
OL Threshold	The load dump overload threshold as a percentage of the genset application rating Parameter: Load Dump Overload Threshold. (Password level: 1.) Allowed values: 80~140 %. (Default: 105 %.)
OL Set Time	The time delay until the load dump overload condition is set active Parameter: Load Dump Overload Set Time. (Password level: 1.) Allowed values: 0~120 seconds. (Default: 60 seconds.)
Load Dump Underfreq	
Threshold	The frequency trip threshold for the load dump underfrequency condition Parameter: Load Dump Underfrequency Threshold. (Password level: 1.) Allowed values: 0~90 Hz.
Offset	The frequency amount which the load dump underfrequency threshold is below the final frequency reference Parameter: Load Dump Underfrequency Offset. (Password level: 1.) Allowed values: 0~10 Hz. (Default: 3 Hz.)
Set Time	The time delay until the load dump underfrequency condition is set active Parameter: Load Dump Underfrequency Set Time. (Password level: 1.) Allowed values: 0~20 seconds. (Default: 3 seconds.)
Overload Warning	
Threshold	Sets the Overload Warning fault trip threshold as percentage of genset application kW rating. Parameter: Overload Warning Threshold. (Password level: 1.) Allowed values: 80~140 %. (Default: 105 %.)
Set Time	The time delay until an overload condition is reported as a fault Parameter: Overload Warning Set Time. (Password level: 1.) Allowed values: 1~120 seconds. (Default: 60 seconds.)
Reverse kW	
Threshold	Sets the Reverse kW fault trip threshold as percentage of Standby kW rating. Parameter: Reverse kW Threshold. (Password level: 1.) Allowed values: 5~30 %. (Default: 10 %.)
Time Delay	Sets the Reverse kW fault trip time delay Parameter: Reverse kW Time Delay. (Password level: 1.) Allowed values: 1~15 seconds. (Default: 3 seconds.)
Reverse kVAR	
Threshold	Sets the Reverse kVAR fault trip threshold as percentage of Standby kW rating. Parameter: Reverse kVAR Threshold. (Password level: 1.) Allowed values: 15~50 %. (Default: 20 %.)
Time Delay	Sets the Reverse kVAR fault trip time delay Parameter: Reverse kVAR Time Delay. (Password level: 1.) Allowed values: 10~60 seconds. (Default: 10 seconds.)
LCT Warning	
Threshold	Sets threshold for the low coolant temp fault warning. Parameter: LCT Warning Threshold. (Password level: 1.) Allowed values: -20~100 degF. (Default: 70 degF.)
Set Time	Sets time to set the low coolant temp fault. Parameter: LCT Warning Set Time. (Password level: 1.) Allowed values: 0~30 Minutes. (Default: 1 Minutes.)
Clear Time	Sets time to clear the low coolant temp fault. Parameter: LCT Warning Clear Time. (Password level: 1.) Allowed values: 0~30 Minutes. (Default: 1 min.)

NAME	DESCRIPTION
LCL Resp	Sets low coolant level fault response to None, Warning or Shutdown. Parameter: LCL Detection Response. (Password level: 2.) Allowed values: None, Warning, Shutdown. (Default: None.)
Lo Fuel Set/Clear	A trim that sets the delay time for generating the inactive and active faults. Parameter: Low Fuel Set/Clear Time. (Password level: 1.) Allowed values: 2~60 seconds. (Default: 2 seconds.)
Lo Fuel Day Trnk	Low Fuel in Day Tank Fault time delay from switch input. Parameter: Low Fuel in Day Tank Time. (Password level: 1.) Allowed values: 0~20 seconds. (Default: 2 seconds.)
Exer Sched En	Enables the exercise scheduler. Parameter: Exercise Scheduler Enable. (Password level: 1.) Allowed values: Disabled, Enabled. (Default: Disabled.)
Scheduler Program	
Select	Used to select a program to adjust. Parameter: Scheduler Program Select. Allowed values: 1~12. (Default: 1.)
Enable	Used to enable or disable the selected program. Parameter: Scheduler Program x Enable. Allowed values: Disable, Enable. (Default: Disable.)
Run Mode	Used to adjust the run mode for the selected program. Parameter: Scheduler Program x Run Mode. Allowed values: No Load, With Load, Extended Parallel. (Default: Once.)
Start Day	Used to adjust the start day of the week for the selected program. Parameter: Scheduler Program x Start Day. Allowed values: Sunday, Monday, Tuesday, Wednesday, Thursday, Friday, Saturday. (Default: Sunday.)
Start Hour	Used to adjust the start hour for the selected program. Parameter: Scheduler Program x Start Hour. Allowed values: 0~23. (Default: 0.)
Start Min	Used to adjust the start minute for the selected program. Parameter: Scheduler Program x Start Minute. Allowed values: 0~59. (Default: 0.)
Duration Hours	Used to adjust the length in hours for the selected program. Parameter: Scheduler Program x Duration Hours. Allowed values: 0~23. (Default: 0.)
Duration Minutes	Used to adjust the length in minutes for the selected program. Parameter: Scheduler Program x Duration Minutes. Allowed values: 1~59. (Default: 1.)
Repeat Interval	Used to adjust the repeat interval for the selected program. Parameter: Scheduler Program x Repeat Interval. Allowed values: Once, Every Week, Every 2 Weeks, Every 3 Weeks, Every 4 Weeks, Every 5 Weeks, First Week of Month, Second Week of Month, Third Week of Month, Fourth Week of Month, Last Week of Month. (Default: Once.)
Scheduler Exception	
Select	Used to select an exception to adjust. Parameter: Scheduler Exception Select. Allowed values: 1~6. (Default: 1.)
Enable	Used to enable or disable the selected exception. Parameter: Scheduler Exception x Enable. Allowed values: Disable, Enable. (Default: Disable.)
Exc Month	Used to adjust the starting month for the selected exception. Parameter: Scheduler Exception x Month. Allowed values: 1~12. (Default: 1.)
Exc Date	Used to adjust the date for the selected exception. Parameter: Scheduler Exception x Date. Allowed values: 1~31. (Default: 1.)

NAME	DESCRIPTION
Exc Hour	Used to adjust the starting hour for the selected exception. Parameter: Scheduler Exception x Hour. Allowed values: 0~23. (Default: 0.)
Exc Minute	Used to adjust the starting minute for the selected exception. Parameter: Scheduler Exception x Minute. Allowed values: 0~59. (Default: 0.)
Exc Duration Days	Used to adjust the length in days for the selected exception. Parameter: Scheduler Exception x Duration Days. Allowed values: 0~44. (Default: 0.)
Exc Duration Hrs	Used to adjust the length in hours for the selected exception. Parameter: Scheduler Exception x Duration Hours. Allowed values: 0~23. (Default: 0.)
Exc Duration Min	Used to adjust the length in minutes for the selected exception. Parameter: Scheduler Exception x Duration Minutes. Allowed values: 0~59. (Default: 0.)
Exc Repeat	Used to adjust the repeat interval for the selected exception. Parameter: Scheduler Exception x Repeat. Allowed values: Once Only, Every Year. (Default: Once Only.)
Delayed Shutdown	
Enable	Enables the Delayed Shutdown feature. Parameter: Delayed Shutdown Enable. (Password level: 1.) Allowed values: Disabled, Enabled. (Default: Disabled.)
Time Delay	Sets the shutdown fault delayed time delay for the Delayed Shutdown feature. Parameter: Delayed Shutdown Time Delay. (Password level: 1.) Allowed values: 0~3 seconds. (Default: 2 seconds.)
Ctrl'd Shutdown	
Unload Time	maximum ramp unload time during a shutdown with cooldown Parameter: Controlled Shutdown Max Ramp Unload Time. (Password level: 1.) Allowed values: 0~300 seconds. (Default: 60 seconds.)
Advance Delay	Delay allowed for a shutdown with cooldown fault prior to shutting down the genset Parameter: Controlled Shutdown Advance Notice Delay. (Password level: 1.) Allowed values: 0~300 seconds. (Default: 60 seconds.)

PCC Net (Setup/PCCnet)

PCCNet Faults

If the PCC loses communication with a HMI 113, the PCC generates shutdown fault 2896 (Critical PCCnet Dev Fail) or warning fault 2895 (PCCnet Device Failed) according to *HMI113 Annunciator PCCNet Failure Response Type*.

If the PCC loses communication with an Operator Panel, the PCC generates shutdown fault 2896 (Critical PCCnet Dev Fail) or warning fault 2895 (PCCnet Device Failed) according to *HMI220 PCCNet Failure Response Type*.

PCC-HMI 113 Communication

The PCC and the HMI 113 exchange four bytes, or thirty-two bits, of information on the PCCNet network. Each bit is identified in Table 3-21.

TABLE 3-21. PCC-HMI 113 COMMUNICATION

BIT	NAME	PCC READS/WRITES
1	Annunciator Fault 1	R
2	Annunciator Fault 2	R
3	Annunciator Fault 3	R
4	Genset Supplying Load	R
5	Charger AC Failure	R / W
6	Low Coolant Level	R / W
7	Low Fuel Level	R / W
8	Check Genset	W
9	Not in Auto	W
10	Genset Running	W
11	High Battery Voltage	W
12	Low Battery Voltage	W
13	Weak Battery	W
14	Fail to Start	W
15	Low Coolant Temp	W
16	Pre-High Engine Temp	W
17	High Engine Temp	W
18	Pre-Low Oil Pressure	W

19	Low Oil Pressure	W
20	Overspeed	W
21	Annunciator Fault Relay 1 Status	R / W
22	Annunciator Fault Relay 2 Status	R / W
23	Annunciator Fault Relay 3 Status	R / W
24	Annunciator Fault Relay 4 Status	R / W
25	Audible Alarm Status	R
26	Silence Button Status	R
27	Network Error Status	R
28	Not Used	Not Used
29	Not Used	Not Used
30	Not Used	Not Used
31	Not Used	Not Used
32	Not Used	Not Used

PCC Information to the HMI 113

Table 3-22 explains the information the PCC sends to the HMI 113.

TABLE 3-22. HMI 113 STATUS INFORMATION

EVENT/FAULT	DESCRIPTION
2993	Charger AC Failure
197 or 235	Low Coolant Level
1441	Low Fuel Level
1483	Check Genset
1463	Not in Auto
1465	Genset Running
442	High Battery Voltage
441	Low Battery Voltage
1442	Weak Battery
359	Fail to Start
1435	Low Coolant Temp
146	Pre-High Engine Temp
151 or 1847	High Engine Temp
143	Pre-Low Oil Pressure
415	Low Oil Pressure
234 or 1992	Overspeed

The PCC can control up to four relays on the HMI 113.

Use *HMI113 Output 1-4 Fault/Event* to specify the event/fault codes that control HMI 113 custom relays 1-4.

The PCC generates warning fault 1944 (HMI113 Out Config Error) if more than one source is controlling one of the HMI 113 custom relays.

HMI 113 Information to the PCC

The PCC also receives these inputs from the HMI 113.

- *Battery Charger AC Failure (HMI113)*¹⁵
- *Low Coolant Level (HMI113)*¹⁶
- *Low Fuel Level (HMI113)*¹⁷
- HMI customer faults 1-3

An input is active if any HMI 113 sends an active signal. An input is inactive if all of the HMI 113 send an inactive signal.

The PCC generates warning fault 2993 (Battery Charger Sw Fail) as soon as *Battery Charger AC Failure (HMI113)* is active.

When *Low Coolant Level (HMI113)* becomes active, the PCC generates shutdown fault 235 (Low Coolant Level), warning fault 197 (Low Coolant Level), or no response at all, depending on *LCL Detection Response*.

The PCC generates warning fault 1441 (Low Fuel Level) when *Low Fuel Level (HMI113)* is active for *Low Fuel Set/Clear Time*.

HMI 113 customer faults 1-3 generate warning fault 1853 (Annunciator Input 1 Fault), warning fault 1854 (Annunciator Input 2 Fault), and warning fault 1855 (Annunciator Input 3 Fault), respectively. Use *HMI113 Fault 1-3 Text* to identify these signals on the Operator Panel.

Each label is described in the following table.

15. This parameter is not available in the Operator Panel. See Table 4-1 (page 4-1).

16. This parameter is not available in the Operator Panel. See Table 4-1 (page 4-1).

17. This parameter is not available in the Operator Panel. See Table 4-1 (page 4-1).

TABLE 3-23. PCCNET SETUP (SETUP/PCCNET)

NAME	DESCRIPTION
HMI220 Fail Rsp	Selects the genset reaction to a loss of an HMI220 Operator Panel as critical or non-critical. A critical response will shutdown the genset when PCCnet communication is lost. Parameter: HMI220 PCCnet Failure Response Type. (Password level: 1.) Allowed values: Critical Device Response, Non-Critical Device Response. (Default: Non-Crit Device Resp.)
HMI320 Fail Rsp	Selects the genset reaction to a loss of an HMI320 Operator Panel as critical or non-critical. A critical response will shutdown the genset when PCCnet communication is lost. Parameter: HMI320 PCCnet Failure Response Type. (Password level: 1.) Allowed values: Critical Device Response, Non-Critical Device Response. (Default: Non-Crit Device Resp.)
HMI113 Fail Rsp	Selects the genset reaction to a loss of an Annunciator as critical or non-critical. Selecting Critical will cause a shutdown when the Annunciator loses communication. Parameter: HMI113 Annunciator PCCnet Failure Response Type. (Password level: 1.) Allowed values: Critical Device Response, Non-Critical Device Response. (Default: Non-Crit Device Resp.)
Device Fail Delay	Selects the time allowed for arbitration to occur before a PCCnet failure fault is generated. Parameter: PCCnet Device Failure Time Delay. (Password level: 2.) Allowed values: 0~250 seconds. (Default: 60 seconds.)
HMI113 Flt 1 Stat	Monitor point for input #1 from the Annunciator. Parameter: HMI113 Fault 1 Status. Allowed values: Inactive, Active.
Flt 1 Txt	Sixteen (16) character text string to enter the configurable fault text for this fault. Parameter: HMI113 Fault 1 Text. (Password level: 1.)
HMI113 Flt 2 Stat	Monitor point for input #2 from the Annunciator. Parameter: HMI113 Fault 2 Status. Allowed values: Inactive, Active.
Flt 2 Txt	Sixteen (16) character text string to enter the configurable fault text for this fault. Parameter: HMI113 Fault 2 Text. (Password level: 1.)
HMI113 Flt 3 Stat	Monitor point for the input #3 from the Annunciator. Parameter: HMI113 Fault 3 Status. Allowed values: Inactive, Active.
Flt 3 Txt	Sixteen (16) character text string to enter the configurable fault text for this fault. Parameter: HMI113 Fault 3 Text. (Password level: 1.)
HMI113 O1 Stat	Parameter to monitor the logic output to the Annunciator relay. Parameter: HMI113 Output 1 Signal Status. Allowed values: Inactive, Active.
HMI113 O1 Flt	Parameter to allow for the entry of the fault/event code which will turn the output relay on and off. Parameter: HMI113 Output 1 Fault/Event. (Password level: 1.) Allowed values: 0~65530. (Default: 0.)
HMI113 O2 Stat	Parameter to monitor the logic output to the Annunciator relay. Parameter: HMI113 Output 2 Signal Status. Allowed values: Inactive, Active.
HMI113 O2 Flt	Parameter to allow for the entry of the fault/event code which will turn the output relay on and off. Parameter: HMI113 Output 2 Fault/Event. (Password level: 1.) Allowed values: 0~65530. (Default: 0.)

NAME	DESCRIPTION
HMI113 O3 Stat	Parameter to monitor the logic output to the Annunciator relay. Parameter: HMI113 Output 3 Signal Status. Allowed values: Inactive, Active.
HMI113 O3 Flt	Parameter to allow for the entry of the fault/event code which will turn the output relay on and off. Parameter: HMI113 Output 3 Fault/Event. (Password level: 1.) Allowed values: 0~65530. (Default: 0.)
HMI113 O4 Stat	Parameter to monitor the logic output to the Annunciator relay. Parameter: HMI113 Output 4 Signal Status. Allowed values: Inactive, Active.
HMI113 O4 Flt	Parameter to allow for the entry of the fault/event code which will turn the output relay on and off. Parameter: HMI113 Output 4 Fault/Event. (Password level: 1.) Allowed values: 0~65530. (Default: 0.)

OEM Setup

Use this screen to select one of these screens.

Alternator Setup (OEM Setup/Alt)

Genset Tuning

These parameters control the automatic voltage regulator (AVR) algorithm.

- K1 (50 Hz)
- K2 (50 Hz)
- K3 (50 Hz)
- AVR Damping Effect (50 Hz)
- K1 (60 Hz)
- K2 (60 Hz)
- K3 (60 Hz)
- AVR Damping Effect (60 Hz)

The PCC uses a standard, 4-coefficient, PID algorithm that runs five hundred times each second.

K1 sets the overall AVR gain. It is a true proportional gain which is multiplied against the voltage error signal.

- K1 should be adjusted to meet the specification for percent off rated voltage during load acceptance and to prevent large voltage overshoots during offloads and genset startup.

- In general, K1 increases in value with increasing generator size.

K2 controls the recovery shape of voltage transients during large-load acceptance and rejection. This is a true integral gain which is multiplied against the sum of all previous errors.

- If K2 is too high, the voltage performance is unstable. If K2 is too low, the voltage performance is slow or has steady-state voltage-offset errors.
- In general, K2 decreases in value with increasing generator size.

K3 affects high-frequency characteristics of the AVR algorithm. It is set for basic stability. In general, it should not need to be adjusted.

K4 is a calculated value. You cannot adjust it. It is set for basic stability.

The damping term is used to calculate K4. It affects high-frequency characteristics of the AVR algorithm. It is set for basic stability. In general, it should not need to be adjusted.

Table 3-24 and Table 3-25 provide standard values for K1–K4 and damping terms for Cummins Generator Technologies (CGT) alternators at 50-Hz and 60-Hz operation.

TABLE 3-24. STANDARD VALUES FOR K1–K4 AND DAMPING TERMS FOR CGT ALTERNATORS (50-HZ OPERATION)

GENERATOR	CGT BC/UC	CGT BC/UC	CGT (NON-P7)
Output Power	< 200 kW	200 kW – 400 kW	> 400 kW
Open-circuit Time Constant	<= 1.2 sec	1.3 sec – 2.2 sec	>= 2.3 sec
K1	3.50	4.5	5.0
K2	1.00	0.80	0.50

K3	84.0	84.0	84.0
K4	12.48 (calculated)	12.48 (calculated)	12.48 (calculated)
Damping	78.0	78.0	78.0
Shunt Gain Multiplier	1.5	1.5	1.5

TABLE 3-25. STANDARD VALUES FOR K1-K4 AND DAMPING TERMS FOR CGT ALTERNATORS (60-HZ OPERATION)

GENERATOR	CGT BC/UC	CGT BC/UC	CGT (NON-P7)
Output Power	< 200 kW	200 kW – 400 kW	> 400 kW
Open-circuit Time Constant	<= 1.2 sec	1.3 sec – 2.2 sec	>= 2.3 sec
K1	3.50	4.5	5.0
K2	1.00	0.80	0.50
K3	86.0	86.0	86.0
K4	11.06 (calculated)	11.06 (calculated)	11.06 (calculated)
Damping	79.0	79.0	79.0
Shunt Gain Multiplier	1.5	1.5	1.5

Genset Voltage

Set the *Genset Nominal Voltage* to the voltage rating of the alternator. *Genset Nominal Voltage* is restricted to these ranges.

Single phase connections:

- *Single phase Genset nom voltage lo limit* < *Genset Nominal Voltage* < *Single phase Genset nom voltage hi limit*

Three phase connections:

- *3 ph high conn Genset nom voltage lo limit* < *Genset Nominal Voltage* < *3 ph high conn Genset nom voltage hi limit*
- *3 ph low conn Genset nom voltage lo limit* < *Genset Nominal Voltage* < *3 ph low conn Genset nom voltage hi limit*

Note: The PCC ignores the potential transformer (PT) ratio if *Genset Nominal Voltage* is less than 600 VAC.

Use *High AC Voltage Trip Characteristic* to specify how quickly the PCC generates shutdown fault 1446 (High AC Voltage).

If *High AC Voltage Trip Characteristic* is Fixed Time, the PCC generates this fault when one or more phase voltages is greater than *High AC Voltage Threshold* for *High AC Voltage Delay*. This is often suitable when the genset is starting motors.

If *High AC Voltage Trip Characteristic* is Inverse Time, the PCC generates this fault more quickly or more slowly depending on the voltage. The more one or more phase voltages is greater than *High AC Voltage Threshold*, the sooner the PCC generates this fault. This behavior is shown in Figure 3-2.

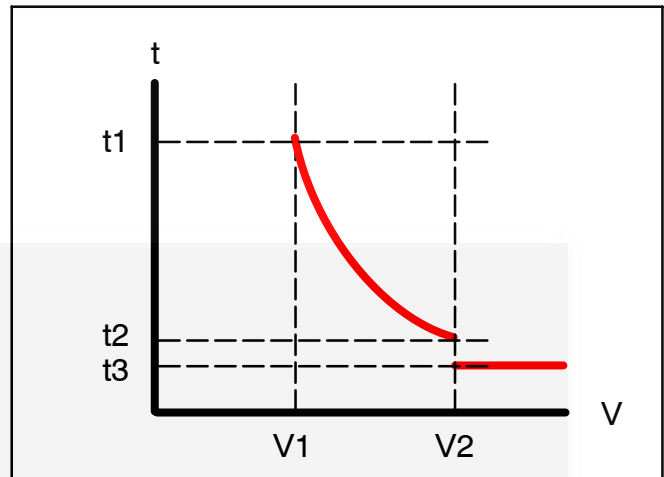

FIGURE 3-2. HIGH AC VOLTAGE FAULT WHEN TRIP CHARACTERISTIC IS INVERSE TIME

TABLE 3-26. HIGH AC VOLTAGE FAULT WHEN TRIP CHARACTERISTIC IS INVERSE TIME

LABEL	DESCRIPTION
t1	<i>High AC Voltage Delay</i>
t2	1 second
t3	0.6 seconds
V1	<i>High AC Voltage Threshold</i>
V2	<i>Instantaneous High AC Voltage Threshold</i>

If the maximum phase voltage is greater than *High AC Voltage Threshold* and less than *Instantaneous*

*High AC Voltage Threshold*¹⁸, the PCC generates shutdown fault 1446 (High AC Voltage) increasingly quickly, from *High AC Voltage Delay* to 1 second.

If the maximum phase voltage is greater than or equal to *Instantaneous High AC Voltage Threshold*, the PCC generates this fault in 0.6 seconds.

The PCC generates shutdown fault 1447 (Low AC Voltage) if one or more phase voltages is less than *Low AC Voltage Threshold* for *Low AC Voltage Delay*.

Pulse-width Modulation (PWM) in the Automatic Voltage Regulator (AVR)

The PCC uses pulse-width modulation (PWM) to drive the field windings in the exciter. The maximum PWM duty cycle depends on *Excitation Source*.

- If *Excitation Source* is PMG, the maximum PWM duty cycle is 60%.

- If *Excitation Source* is Shunt, the maximum PWM duty cycle is 68%.

The PCC generates shutdown fault 2972 (Field Overload) if the PCC drives the field windings in the exciter at the maximum PWM duty cycle for *Max Field Time*.

Ready to Load

Event 1465 (Ready to Load) is active when these conditions are met.

- The genset is running at 90% rated voltage.
- The genset is running at 90% rated frequency.
- The PCC is in Auto mode (page 2-8); or the PCC is in Manual mode (page 2-10), and *Excitation Disable Override* is Excitation On.

Each label is described in the following table.

TABLE 3-27. OEM ALT SETUP (OEM SETUP/ALT)

NAME	DESCRIPTION
Three Phase Voltage Limits	
Ser High Limit	High voltage setpoint limit for the high connection on a reconnectable alternator Parameter: 3 ph high conn Genset nom voltage hi limit. (Password level: 2.) Allowed values: 1~45000 Vac. (Default: 45000 Vac.)
Ser Low Limit	Low voltage setpoint limit for the high connection on a reconnectable alternator Parameter: 3 ph high conn Genset nom voltage lo limit. (Password level: 2.) Allowed values: 1~45000 Vac. (Default: 1 Vac.)
Par High Limit	High voltage setpoint limit for the low connection on a reconnectable alternator Parameter: 3 ph low conn Genset nom voltage hi limit. (Password level: 2.) Allowed values: 1~45000 Vac. (Default: 45000 Vac.)
Par Low Limit	Low voltage setpoint limit for the low connection on a reconnectable alternator Parameter: 3 ph low conn Genset nom voltage lo limit. (Password level: 2.) Allowed values: 1~45000 Vac. (Default: 1 Vac.)
Single Phase Voltage Limits	
High Limit	High voltage setpoint limit for the single phase connected alternator Parameter: Single phase Genset nom voltage hi limit. (Password level: 2.) Allowed values: 1~600 Vac. (Default: 45000 Vac.)
Low Limit	Low voltage setpoint limit for the single phase connected alternator Parameter: Single phase Genset nom voltage lo limit. (Password level: 2.) Allowed values: 1~600 Vac. (Default: 1 Vac.)
Genset	
PT Primary	Genset PT primary voltage Parameter: Genset PT Primary Voltage. (Password level: 2.) Allowed values: 600~45000 Vac. (Default: 600 Vac.)
PT Sec	Genset PT secondary voltage Parameter: Genset PT Secondary Voltage. (Password level: 2.) Allowed values: 100~600 Vac. (Default: 240 Vac.)
CT Primary	Genset CT primary current Parameter: Genset Primary CT Current. (Password level: 2.) Allowed values: 5~10000 Amps. (Default: 1 Amps.)

18. This parameter is not available in the Operator Panel. See Table 4-1 (page 4-1).

NAME	DESCRIPTION
CT Sec	Genset CT secondary current Parameter: Genset CT Secondary Current. (Password level: 2.) Allowed values: 1 Amp, 5 Amp. (Default: 1.)
High ACV Thld	Percent of desired voltage at which High AC Voltage fault becomes active. Parameter: High AC Voltage Threshold. (Password level: 1.) Allowed values: 105~125 %. (Default: 110 %.)
High ACV Trip	“Fixed Time” setup allows a greater time delay until shutdown when voltage overshoots (good for starting motors). When the control is set up to operate as “Inverse Time”, the fault will be more sensitive to voltage spikes and will trip more rapidly. Parameter: High AC Voltage Trip Characteristic. (Password level: 1.) Allowed values: Inverse Time, Fixed Time.
High ACV Delay	Time delay before High AC Voltage fault becomes active. Parameter: High AC Voltage Delay. (Password level: 1.) Allowed values: 0.1~10 seconds. (Default: 10 seconds.)
Lost ACV Delay	Sets the time delay for the Loss of AC Voltage Sensing fault. Parameter: Lost AC Time Delay. (Password level: 1.) Allowed values: 0~25.5 seconds. (Default: 1 seconds.)
Lost ACV Thld	Sets average voltage threshold for Loss of AC Voltage sensing fault. Parameter: Lost AC Voltage Threshold. (Password level: 2.) Allowed values: 0~25 %. (Default: 10 %.)
Low ACV Thld	Percent of desired voltage at which Low AC Voltage fault becomes active. Parameter: Low AC Voltage Threshold. (Password level: 1.) Allowed values: 50~95 %. (Default: 85 %.)
Low ACV Delay	Time delay before Low AC Voltage fault becomes active Parameter: Low AC Voltage Delay. (Password level: 1.) Allowed values: 2~20 seconds. (Default: 10 seconds.)
Underfreq Thld	Number of Hertz Alternator Line Frequency may be under nominal frequency before Underfrequency fault becomes active. Parameter: Underfrequency Threshold. (Password level: 1.) Allowed values: 2~10 Hz. (Default: 6 Hz.)
Underfreq Delay	Time delay before the Underfrequency fault becomes active. Parameter: Underfrequency Delay. (Password level: 1.) Allowed values: 5~20 seconds. (Default: 10 seconds.)
Overfreq En	Enables overfrequency diagnostic witness test. Parameter: Overfrequency Enable. (Password level: 1.) Allowed values: Disabled, Enabled. (Default: Disabled.)
Overfreq Thld	Number of Hertz Alternator Line Frequency may be over nominal frequency before Overfrequency fault becomes active. Parameter: Overfrequency Threshold. (Password level: 1.) Allowed values: 2~10 Hz. (Default: 6 Hz.)
Overfreq Delay	Time delay before Overfrequency fault becomes active. Parameter: Overfrequency Delay. (Password level: 1.) Allowed values: 1~20 seconds. (Default: 20 seconds.)
Speed/Frequency Threshold	Sets the threshold for generating the Speed/Frequency mismatch fault Parameter: Speed/Frequency Threshold. (Password level: 1.) Allowed values: 0.5~20 Hz. (Default: 1.5 Hz.)
Delay	Sets the delay time for generating the Speed/Frequency mismatch fault Parameter: Speed/Frequency Delay. (Password level: 1.) Allowed values: 0.5~10 seconds. (Default: 1 seconds.)
Max Field Time	The maximum allowed time at Max Field Duty Cycle. Parameter: Max Field Time. (Password level: 1.) Allowed values: 3~30 seconds. (Default: 15 seconds.)
K1 (50 Hz)	This gain affects the overall regulator gain in 50 Hz applications. Similar to proportional gain. Parameter: K1 (50 Hz). (Password level: 2.) Allowed values: 0~100 %DC / %Volts. (Default: 4 %DC / %Volts.)

NAME	DESCRIPTION
K1 (60 Hz)	This gain affects the overall regulator gain in 60 Hz applications. Similar to proportional gain. Parameter: K1 (60 Hz). (Password level: 2.) Allowed values: 0~100 %DC / %Volts. (Default: 4 %DC / %Volts.)
K2 (50 Hz)	This is gain 2 in 50 Hz applications. (1-K2) is z plane zero location. Similar to integral gain. Parameter: K2 (50 Hz). (Password level: 2.) Allowed values: 0.02~99.99. (Default: 1.)
K2 (60 Hz)	This is gain 2 in 60 Hz applications. (1-K2) is z plane zero location. Similar to integral gain. Parameter: K2 (60 Hz). (Password level: 2.) Allowed values: 0.02~99.99. (Default: 1.)
K3 (50 Hz)	This is gain 3 in 50 Hz applications. K3 is z plane pole location. (K3+K4) is z plane zero location. Parameter: K3 (50 Hz). (Password level: 2.) Allowed values: 0~100. (Default: 84.)
K3 (60 Hz)	This is gain 3 in 60 Hz applications. K3 is z plane pole location. (K3+K4) is z plane zero location. Parameter: K3 (60 Hz). (Password level: 2.) Allowed values: 0~100. (Default: 86.)
AVR Damp 50	Increases or decreases the output response of the AVR. A lower input value will increase the transient response. A higher value will decrease the transient response. Parameter: AVR Damping Effect (50 Hz). (Password level: 2.) Allowed values: 0~99.99. (Default: 78.)
AVR Damp 60	Increases or decreases the output response of the AVR. A lower input value will increase the transient response. A higher value will decrease the transient response. Parameter: AVR Damping Effect (60 Hz). (Password level: 2.) Allowed values: 0~99.99. (Default: 79.)
Excitation	The type of excitation power source PMG or Shunt Parameter: Excitation Source. (Password level: 2.) Allowed values: Shunt, PMG. (Default: PMG.)
Ex Dis Over	Use to turn off AVR while running in Manual for troubleshooting Parameter: Excitation Disable Override. (Password level: 1.) Allowed values: Excitation Off, Excitation On. (Default: Excitation On.)

Engine Setup (OEM Setup/Engine)

Each label is described in the following table.

TABLE 3-28. OEM ENGINE SETUP (OEM SETUP/ENGINE)

NAME	DESCRIPTION
ECM CAN En	Set to Disabled if there is no ECM (HMECM or otherwise) connected to the control. Parameter: ECM CAN Enable. (Password level: 2.) Allowed values: Disabled, J1939, PGI (Enabled).
Datasave Dly	A trim that sets the delay time for the ECM Dataplate saves Parameter: ECM Datasave Time Delay. (Password level: 2.) Allowed values: 0~60 seconds. (Default: 30 seconds.)
Keysw Retries	Sets the maximum number of CAN communication retries Parameter: CAN Failure Retries. (Password level: 1.) Allowed values: 0~10. (Default: 3.)
Key Min On	Minimum time the keyswitch driver command needs to be on before CAN datalink health will be checked Parameter: Keyswitch Minimum On Time. (Password level: 2.) Allowed values: 0.1~5 seconds. (Default: 1 seconds.)

NAME	DESCRIPTION
Flt Code 1117	Used to Enable/Disable fault 1117 on the genset control. Fault will be ignored with a disabled setting. Parameter: Fault Code 1117 Enable. (Password level: 1.) Allowed values: Disabled, Enabled. (Default: Enabled.)
Starter Owner	Tells the GCS which control system has starter control Parameter: Starter Owner. (Password level: 2.) Allowed values: GCS, ECS. (Default: GCS.)
24V Batt Flt Thresholds	
High Battery	Sets 24V high battery voltage fault threshold Parameter: 24 V High Battery Voltage Threshold. (Password level: 1.) Allowed values: 28~34 Vdc. (Default: 32 Vdc.)
Weak Battery	Sets 24V weak battery voltage fault threshold Parameter: 24 V Weak Battery Voltage Threshold. (Password level: 1.) Allowed values: 12~16 Vdc. (Default: 14.4 Vdc.)
Low Battery	Sets 24V low battery voltage fault threshold for genset operation while in rated mode Parameter: 24 V Low Battery Voltage Running Threshold. (Password level: 1.) Allowed values: 24~28 Vdc. (Default: 24 Vdc.)
Low Batt Stop	Sets 24V low battery voltage fault threshold for genset operation in all modes except rated Parameter: 24 V Low Battery Voltage Stopped Threshold. (Password level: 1.) Allowed values: 22~26 Vdc. (Default: 24 Vdc.)
12V Batt Flt Thresholds	
High Battery	Sets 12V high battery voltage fault threshold. Parameter: 12 V High Battery Voltage Threshold. (Password level: 1.) Allowed values: 14~17 Vdc. (Default: 16 Vdc.)
Weak Battery	Sets 12V weak battery voltage fault threshold Parameter: 12 V Weak Battery Voltage Threshold. (Password level: 1.) Allowed values: 6~10 Vdc. (Default: 8 Vdc.)
Low Battery	Sets 12V low battery voltage fault threshold for genset operation while in rated mode Parameter: 12 V Low Battery Voltage Running Threshold. (Password level: 1.) Allowed values: 12~16 Vdc. (Default: 12 Vdc.)
Low Batt Stop	Sets 12V low battery voltage fault threshold for genset operation in all modes except rated Parameter: 12 V Low Battery Voltage Stopped Threshold. (Password level: 1.) Allowed values: 11~13 Vdc. (Default: 12 Vdc.)
Batt Flt Set Times	
High Battery	The time delay until a high battery voltage condition is reported as a fault. Parameter: High Battery Voltage Set Time. (Password level: 1.) Allowed values: 2~60 seconds. (Default: 60 seconds.)
Weak Battery	The time delay until a weak battery condition is reported as a fault Parameter: Weak Battery Voltage Set Time. (Password level: 1.) Allowed values: 1~5 seconds. (Default: 2 seconds.)
Low Battery	The time delay until a low battery voltage condition is reported as a fault Parameter: Low Battery Voltage Set Time. (Password level: 1.) Allowed values: 2~60 seconds. (Default: 60 seconds.)
Char Alt Flt Dly	Sets the time delay for the charging alt failure fault Parameter: Charging Alternator Fault Time Delay. (Password level: 1.) Allowed values: 2~300 seconds. (Default: 120 seconds.)
Alt Freq Sw	Sets the genset nominal frequency. Parameter: Alternate Frequency Switch. (Password level: 1.) Allowed values: 50 Hz, 60 Hz. (Default: 60Hz.)
V/Hz Knee	The voltage will roll off (decrease) proportionally to the V/Hz setup, once the frequency drops below the set point in the V/Hz Knee Frequency. This allows the genset to recover faster when the frequency drops. Parameter: V/Hz Knee Frequency. (Password level: 1.) Allowed values: 0~10 Hz. (Default: 1 Hz.)

NAME	DESCRIPTION
V/Hz Slope	The amount of voltage roll off when the frequency is below the knee frequency Parameter: V/Hz Rolloff Slope. (Password level: 1.) Allowed values: 0~10 % / Hz. (Default: 2.2 % / Hz.)
F/S Gain Sel	Sets the rpm/Hz conversion factor which is a function of the poles of the alternator and/or any gearboxes Parameter: Frequency to Speed Gain Select. (Password level: 2.) Allowed values: 60 rpm/Hz, 30 rpm/Hz, 20 rpm/Hz, 36 rpm/Hz, Adjustable Freq/Speed Gain. (Default: 30 rpm/Hz.)
Adj F/S Gain	Sets the rpm/Hz conversion factor when the Freq to Speed Gain Select trim is set to this trim Parameter: Adjustable Freq/Speed Gain. (Password level: 2.) Allowed values: 0~240 rpm/Hz. (Default: 30 rpm/Hz.)
Prelube Fn	Selects whether the Prelube function is enabled or disabled. This is Setup mode interlocked Parameter: Prelube Function Enable. (Password level: 1.) Allowed values: Disabled, Enabled. (Default: Disabled.)
Nom Batt Vlt	Selects the genset's nominal battery operating voltage Parameter: Nominal Battery Voltage. (Password level: 2.) Allowed values: 12 V, 24 V. (Default: 24V.)
Strt to Rtd Rmp	The time over which the speed reference is to ramp from starting speed to rated speed Parameter: Starting to Rated Ramp Time. (Password level: 1.) Allowed values: 0~30 seconds. (Default: 1 seconds.)

Genset Setup (OEM Setup/Genset)

Application Rating

The PCC uses the application rating to protect the genset against overload conditions. The rating is measured in kVA.

The PCC stores up to twelve kVA ratings. Use these parameters to specify the appropriate one.

- *Application Rating Select*
- *Alternate Frequency Switch*
- *Single/3 Phase Connection*

Genset Frequency

Set the *Alternate Frequency Switch* to the desired genset frequency. The *Alternate Frequency Switch*

is restricted to the values allowed in *Frequency Options*.

You can monitor the genset frequency in *Genset Frequency*. Use *Frequency Adjust* to calibrate the measured value.

The PCC generates shutdown fault 1448 (Under frequency) if the genset frequency is *Underfrequency Threshold* under the *Alternate Frequency Switch* for *Underfrequency Delay*. The genset must also be running at 90% rated voltage.

The PCC generates warning fault 1449 (Overfrequency) if the genset frequency is *Overfrequency Threshold* over the *Alternate Frequency Switch* for *Overfrequency Delay*. The genset must also be running at 90% rated voltage.

Each label is described in the following table.

TABLE 3-29. OEM GENSET SETUP (OEM SETUP/GENSET)

NAME	DESCRIPTION
Gen Ser #	Serial number of identifying this genset. Parameter: Genset Serial Number. (Password level: 2.)
Gen Mod #	Number identifying the model of this genset. Parameter: Genset Model Number. (Password level: 2.)
Alt Ser #	Unique number identifying this gensets alternator serial number. Parameter: Alternator Serial Number. (Password level: 2.)
Alt Mod #	Number identifying this gensets alternator model number. Parameter: Alternator Model Number. (Password level: 2.)
Eng Ser #	Unique number identifying this genset's engine serial number. Parameter: Engine Serial Number. (Password level: 2.)

NAME	DESCRIPTION
Freq Options	Sets the allowed options for the Alternate Frequency Switch Parameter: Frequency Options. (Password level: 2.) Allowed values: 50 Hz or 60 Hz, 50 Hz Only, 60 Hz Only. (Default: 60Hz or 50Hz.)
Prime/Standby	Selects genset's standby/prime/base application rating. Parameter: Application Rating Select. (Password level: 1.) Allowed values: Standby, Prime, Base. (Default: Standby.)
Rem Flt Rst En	Parameter: Enable Remote Fault Reset. (Password level: 1.) Allowed values: Disable, Enable. (Default: Disabled.)
LCL Resp	Sets low coolant level fault response to None, Warning or Shutdown. Parameter: LCL Detection Response. (Password level: 2.) Allowed values: None, Warning, Shutdown. (Default: None.)
Engine Hours	Total engine run time Parameter: Engine Running Time.
Standby kVA Rating	
3Ph/50 Hz	KVA rating of genset when operating in Standby mode, at 50 Hz, and 3 phase. Parameter: Standby kVA rating (3 phase/ 50Hz). (Password level: 2.) Allowed values: 1~6000 kVA. (Default: 1 kVA.)
3Ph/60 Hz	KVA rating of genset when operating in Standby mode, at 60 Hz, and 3 phase. Parameter: Standby kVA rating (3 phase/ 60Hz). (Password level: 2.) Allowed values: 1~6000 kVA. (Default: 1 kVA.)
1Ph/50 Hz	KVA rating of genset when operating in Standby mode, at 50 Hz, and single phase. Parameter: Standby kVA rating (single phase/ 50Hz). (Password level: 2.) Allowed values: 1~6000 kVA. (Default: 1 kVA.)
1Ph/60 Hz	KVA rating of genset when operating in Standby mode, at 60 Hz, and single phase. Parameter: Standby kVA rating (single phase/ 60Hz). (Password level: 2.) Allowed values: 1~6000 kVA. (Default: 1 kVA.)
Prime kVA Rating	
3Ph/50 Hz	KVA rating of genset when operating in Prime Power mode, at 50 Hz, and 3 phase. Parameter: Prime kVA rating (3 phase/ 50Hz). (Password level: 2.) Allowed values: 1~6000 kVA. (Default: 1 kVA.)
3Ph/60 Hz	KVA rating of genset when operating in Prime Power mode, at 60 Hz, and 3 phase. Parameter: Prime kVA rating (3 phase/ 60Hz). (Password level: 2.) Allowed values: 1~6000 kVA. (Default: 1 kVA.)
1Ph/50 Hz	KVA rating of genset when operating in Prime Power mode, at 50 Hz, and single phase. Parameter: Prime kVA rating (single phase/ 50Hz). (Password level: 2.) Allowed values: 1~6000 kVA. (Default: 1 kVA.)
1Ph/60 Hz	KVA rating of genset when operating in Standby mode, at 60 Hz, and single phase. Parameter: Prime kVA rating (single phase/ 60Hz). (Password level: 2.) Allowed values: 1~6000 kVA. (Default: 1 kVA.)
Factory Input Locks	
Cust Fault 1	Prevents Input Function Pointer from being modified unless in Factory mode Parameter: Configurable Input #1 Factory Lock. (Password level: 2.) Allowed values: Not Locked, Locked. (Default: Not Locked.)
Cust Fault 2	Prevents Input Function Pointer from being modified unless in Factory mode Parameter: Configurable Input #2 Factory Lock. (Password level: 2.) Allowed values: Not Locked, Locked. (Default: Not Locked.)
Cool Level 5	Prevents Input Function Pointer from being modified unless in Factory mode Parameter: Coolant Level/Configurable Input #5 Factory Lock. (Password level: 2.) Allowed values: Not Locked, Locked. (Default: Locked.)

NAME	DESCRIPTION
Low Fuel 6	Prevents Input Function Pointer from being modified unless in Factory mode Parameter: Low Fuel/Configurable Input #6 Factory Lock. (Password level: 2.) Allowed values: Not Locked, Locked. (Default: Locked.)
Fault Rst 10	Prevents Input Function Pointer from being modified unless in Factory mode Parameter: Fault Reset/Configurable Input #10 Factory Lock. (Password level: 2.) Allowed values: Not Locked, Locked. (Default: Not Locked.)
Start Typ 11	Prevents Input Function Pointer from being modified unless in Factory mode Parameter: Start Type/Configurable Input #11 Factory Lock. (Password level: 2.) Allowed values: Not Locked, Locked. (Default: Not Locked.)
Rupt Bas 12	Prevents Input Function Pointer from being modified unless in Factory mode Parameter: Rupture Basin/Configurable Input #12 Factory Lock. (Password level: 2.) Allowed values: Not Locked, Locked. (Default: Locked.)
Cust Fault 13	Prevents Input Function Pointer from being modified unless in Factory mode Parameter: Configurable Input #13 Factory Lock. (Password level: 2.) Allowed values: Not Locked, Locked. (Default: Not Locked.)
Cust Fault 14	Prevents Input Function Pointer from being modified unless in Factory mode Parameter: Configurable Input #14 Factory Lock. (Password level: 2.) Allowed values: Not Locked, Locked. (Default: Not Locked.)
Output 1	Prevents Output Function Pointer and Invert Bypass from being modified unless in Factory mode Parameter: Configurable Output #1 Factory Lock. (Password level: 2.) Allowed values: Not Locked, Locked. (Default: Not Locked.)
Output 2	Prevents Output Function Pointer and Invert Bypass from being modified unless in Factory mode Parameter: Configurable Output #2 Factory Lock. (Password level: 2.) Allowed values: Not Locked, Locked. (Default: Not Locked.)
Output 3	Prevents Output Function Pointer and Invert Bypass from being modified unless in Factory mode Parameter: Configurable Output #3 Factory Lock. (Password level: 2.) Allowed values: Not Locked, Locked. (Default: Not Locked.)
Output 4	Prevents Output Function Pointer and Invert Bypass from being modified unless in Factory mode Parameter: Configurable Output #4 Factory Lock. (Password level: 2.) Allowed values: Not Locked, Locked. (Default: Not Locked.)
Rdy To Ld 5	Controls whether the output function is inverted or not. If bypassed the function is not inverted Parameter: Ready To Load / Configurable Output #5 Factory Lock. (Password level: 2.) Allowed values: Not Locked, Locked. (Default: Not Locked.)
Prime Pump 6	Prevents Output Function Pointer and Invert Bypass from being modified unless in Factory mode Parameter: Oil Priming Pump / Configurable Output #6 Factory Lock. (Password level: 2.) Allowed values: Not Locked, Locked. (Default: Locked.)
Local Stat 7	Prevents Output Function Pointer and Invert Bypass from being modified unless in Factory mode Parameter: Local Status / Configurable Output #7 Factory Lock. (Password level: 2.) Allowed values: Not Locked, Locked. (Default: Not Locked.)
Glow Plug 8	Prevents Output Function Pointer and Invert Bypass from being modified unless in Factory mode Parameter: Glow Plug / Configurable Output #8 Factory Lock. (Password level: 2.) Allowed values: Not Locked, Locked. (Default: Not Locked.)

NAME	DESCRIPTION
Dlyed Off 10	Prevents Output Function Pointer and Invert Bypass from being modified unless in Factory mode Parameter: Delayed Off / Configurable Output #10 Factory Lock. (Password level: 2.) Allowed values: Not Locked, Locked. (Default: Not Locked.)
Load Dump 11	Prevents Output Function Pointer and Invert Bypass from being modified unless in Factory mode Parameter: Load Dump / Configurable Output #11 Factory Lock. (Password level: 2.) Allowed values: Not Locked, Locked. (Default: Not Locked.)
Fail Shutdn Dly	Trim to set the time for a shutdown fault to be active and the genset not shutting down before the Fail to Shutdown fault occurs. Parameter: Fail To Shutdown Delay. (Password level: 2.) Allowed values: 0~30 seconds. (Default: 5 seconds.)
Battle Short	Trim to enable Battle Short. Parameter: Battle Short Enable. (Password level: 1.) Allowed values: Disable, Enable. (Default: Disabled.)
Gen Idle En	Enables or Disable idling of genset with external governor. Parameter: Genset Idle Enable. Allowed values: Disabled, Enabled. (Default: Enabled.)
Dly Shutdn En	Enables the Delayed Shutdown feature. Parameter: Delayed Shutdown Enable. (Password level: 1.) Allowed values: Disabled, Enabled. (Default: Disabled.)
Dly Shutdn Dly	Sets the shutdown fault delayed time delay for the Delayed Shutdown feature. Parameter: Delayed Shutdown Time Delay. Allowed values: 0~3 seconds. (Default: 2 seconds.)
Reset Fuel Cons	The reset trip fuel consumption command. Parameter: Reset Fuel Consumption. (Password level: 1.) Allowed values: Inactive, Active. (Default: Inactive.)
Reset Runs	The reset runs command. Parameter: Reset Runs. (Password level: 1.) Allowed values: Inactive, Active.
Reset Starts	The reset start attempts command. Parameter: Reset Start Attempts. (Password level: 1.) Allowed values: Inactive, Active.

SAVE RESTORE**HISTORY-ABOUT (HISTORY/ABOUT)**

This is reserved for future use.

Each label is described in the following table.

TABLE 3-30. HISTORY-ABOUT (HISTORY/ABOUT)

NAME	DESCRIPTION
Total Starts	Total number of start attempts. Parameter: Total Start Attempts. Allowed values: 0~65535.
Total Runs	Total number of genset runs. Parameter: Total Number of Runs. Allowed values: 0~65535.
Engine Hours	Total engine run time Parameter: Engine Running Time.
Control Hrs	Controller ON time in seconds. Upper limit is 136 years. Parameter: Controller On Time. Allowed values: 0~4294967295 hours.
Gen Mod #	Number identifying the model of this genset. Parameter: Genset Model Number. (Password level: 2.)
Gen Ser #	Serial number of identifying this genset. Parameter: Genset Serial Number.

NAME	DESCRIPTION
Nom Voltage	Genset nominal line-line voltage Parameter: Genset Nominal Voltage. (Password level: 1.) Allowed values: 1~45000 Vac. (Default: 1 Vac.)
Wye/Delta	Delta or Wye for Genset connection Parameter: Genset Delta/Wye Connection. (Password level: 1.) Allowed values: Delta, Wye. (Default: Wye.)
Rating Select	Selects genset's standby/prime/base application rating. Parameter: Application Rating Select. (Password level: 1.) Allowed values: Standby, Prime, Base. (Default: Standby.)
Control Type	Used by the PC Tool. Parameter: Controller Device Type. Allowed values: Unknown, PCC 2300, PCC 3300, PCC 1302.
kW Hours	Genset total net kWh accumulation Parameter: Genset Total Net kWh.
Firmware Ver	Version of S/W loaded into this control. Obtained from PPC Filename. Parameter: Firmware Version Number.
Calib Part	The unique calibration part number loaded into this control. Parameter: Calibration Part Number. (Password level: 3.)
Calib Date	The revision date of the calibration part number loaded into this control. Parameter: Calibration Revision Date. (Password level: 3.)
ECM Code	The calibration code the ECM is sending Parameter: ECM Code.
HMI Boot Ver	Parameter: HMI Local Parameter.
HMI Firmware Ver	Parameter: HMI Local Parameter.
50Hz kW Load Profile	This shows how long the genset has been running (50-Hz operation) at various percentages of its rated load.
60Hz kW Load Profile	This shows how long the genset has been running (60-Hz operation) at various percentages of its rated load.

ADVANCED STATUS**Genset Status (Adv Genset Status)**

Use this screen to select one of these screens. Each label is described in the following table.

TABLE 3-31. GENSET STATUS (ADV GENSET STATUS)

NAME	DESCRIPTION
Genset kWh+	
L1	Genset L1 positive kWh accumulation Parameter: Genset L1 Positive kWh. Allowed values: 0~4294967295 kWh. (Default: 0 kWh.)
L2	Genset L2 positive kWh accumulation Parameter: Genset L2 Positive kWh. Allowed values: 0~4294967295 kWh. (Default: 0 kWh.)
L3	Genset L3 positive kWh accumulation Parameter: Genset L3 Positive kWh. Allowed values: 0~4294967295 kWh. (Default: 0 kWh.)
Total kWh	Genset total net kWh accumulation Parameter: Genset Total Net kWh.
Genset kWh-	
L1	Genset L1 negative kWh accumulation Parameter: Genset L1 Negative kWh. Allowed values: 0~4294967295 kWh. (Default: 0 kWh.)
L2	Genset L2 negative kWh accumulation Parameter: Genset L2 Negative kWh. Allowed values: 0~4294967295 kWh. (Default: 0 kWh.)
L3	Genset L3 negative kWh accumulation Parameter: Genset L3 Negative kWh. Allowed values: 0~4294967295 kWh. (Default: 0 kWh.)
Total kWh	Genset total net kWh accumulation Parameter: Genset Total Net kWh.
Genset kVARh +	

NAME	DESCRIPTION
L1	Genset L1 positive kVARh accumulation Parameter: Genset L1 Positive kVARh. Allowed values: 0~4294967295 kVARh. (Default: 0 kVARh.)
L2	Genset L2 positive kVARh accumulation Parameter: Genset L2 Positive kVARh. Allowed values: 0~4294967295 kVARh. (Default: 0 kVARh.)
L3	Genset L3 positive kVARh accumulation Parameter: Genset L3 Positive kVARh. Allowed values: 0~4294967295 kVARh. (Default: 0 kVARh.)
Total kVARh	Genset total net kVARh accumulation Parameter: Genset Total Net kVARh.
Genset kVARh -	
L1	Genset L1 negative kVARh accumulation Parameter: Genset L1 Negative kVARh. Allowed values: 0~4294967295 kVARh. (Default: 0 kVARh.)
L2	Genset L2 negative kVARh accumulation Parameter: Genset L2 Negative kVARh. Allowed values: 0~4294967295 kVARh. (Default: 0 kVARh.)
L3	Genset L3 negative kVARh accumulation Parameter: Genset L3 Negative kVARh. Allowed values: 0~4294967295 kVARh. (Default: 0 kVARh.)
Total kVARh	Genset total net kVARh accumulation Parameter: Genset Total Net kVARh.
Genset kVAh	
L1	Energy output of L1 in KVAh. Parameter: Genset L1 kVAh. Allowed values: 0~4294967295 kVAh. (Default: 0 kVAh.)
L2	Genset L2 kVAh accumulation Parameter: Genset L2 kVAh. Allowed values: 0~4294967295 kVAh. (Default: 0 kVAh.)
L3	Genset L3 kVAh accumulation Parameter: Genset L3 kVAh. Allowed values: 0~4294967295 kVAh. (Default: 0 kVAh.)
Genset L-N Voltage	
L1-N	Genset L1N voltage% Parameter: Genset L1N Voltage%.
L2-N	Genset L2N voltage% Parameter: Genset L2N Voltage%.
L3-N	Genset L3N voltage% Parameter: Genset L3N Voltage%.
Gen Avg Volt	Genset average voltage percentage. Parameter: Genset Average Voltage%.
Genset L-L Voltage	
L1-L2	Genset L1L2 voltage% Parameter: Genset L1L2 Voltage%.
L2-L3	Genset L2L3 voltage% Parameter: Genset L2L3 Voltage%.
L3-L1	Genset L3L1 voltage% Parameter: Genset L3L1 Voltage%.
H/W Avg Volt	Monitor point for Genset 3 Phase Fast Average Voltage Percent Parameter: Genset 3 Phase Fast Average Voltage Percent.
Genset % Application	
L1 L2 L3	Alternator terminals.
kW	Monitors the genset application L1 KW percentage output. Parameter: Genset % Application L1 kW. Monitors the genset application L2 KW percentage output. Parameter: Genset % Application L2 kW. Monitors the genset application L3 KW percentage output. Parameter: Genset % Application L3 kW.

NAME	DESCRIPTION
kVA	Monitors the genset application L1 KVA percentage output. Parameter: Genset % Application L1 kVA. Monitors the genset application L2 KVA percentage output. Parameter: Genset % Application L2 kVA. Monitors the genset application L3 KVA percentage output. Parameter: Genset % Application L3 kVA.
Amps	Monitors the genset application L1 current percentage output. Parameter: Genset % Application L1 Current. Monitors the genset application L2 current percentage output. Parameter: Genset % Application L2 Current. Monitors the genset application L3 current percentage output. Parameter: Genset % Application L3 Current.
Genset % Standby (Amps)	
L1	Monitors the genset standby L1 current percentage output. Parameter: Genset % Standby L1 Current.
L2	Monitors the genset standby L2 current percentage output. Parameter: Genset % Standby L2 Current.
L3	Monitors the genset standby L3 current percentage output. Parameter: Genset % Standby L3 Current.
Genset % Total	
App Total kVA	Monitors the total genset application KVA percentage output. Parameter: Genset % Application Total kVA.
App Total kW	Monitors the total genset application KW percentage output. Parameter: Genset % Application Total kW.
Stdby Total kVA	Monitors the total genset standby KVA percentage output. Parameter: Genset % Standby Total kVA.
Stdby Total kW	Monitors the total genset standby KW percentage output. Parameter: Genset % Standby Total kW.
Genset Total kWh	
Positive	Genset total positive kWh accumulation Parameter: Genset Total Positive kWh.
Negative	Genset total negative kWh accumulation Parameter: Genset Total Negative kWh.
Net	Genset total net kWh accumulation Parameter: Genset Total Net kWh.
Genset Total kVARh	
Positive	Genset total positive kVARh accumulation Parameter: Genset Total Positive kVARh.
Negative	Genset total negative kVARh accumulation Parameter: Genset Total Negative kVARh.
Net	Genset total net kVARh accumulation Parameter: Genset Total Net kVARh.
Total kVAh	Genset total kVAh accumulation Parameter: Genset Total kVAh.
Total kVAR	Genset total kVAR Parameter: Genset Total kVAR.
L1 kVAR	Genset L1 kVAR Parameter: Genset L1 kVAR.
L2 kVAR	Genset L2 Kvar Parameter: Genset L2 kVAR.
L3 kVAR	Genset L3 Kvar Parameter: Genset L3 kVAR.
L1L2 Ph Diff	Genset L1L2 voltage phase angle Parameter: Genset L1L2 Phase Difference.
L2L3 Ph Diff	Genset L2L3 voltage phase angle Parameter: Genset L2L3 Phase Difference.
L3L1 Ph Diff	Genset L3L1 voltage phase angle Parameter: Genset L3L1 Phase Difference.

NAME	DESCRIPTION
Ph Rotation	Genset phase rotation Parameter: Genset Phase Rotation. Allowed values: L1-L2-L3, L1-L3-L2, Not Available.
Bargraph Mods	Used to monitor the amount of connected Bargraph modules. Parameter: Number of Connected Bargraph Modules. Allowed values: 0~255.
Prelube Mode	Set to a required mode based on the type of starting requirement Parameter: Prelube Mode. Allowed values: Crank After Prelube, Crank With Prelube, Prelube Only.

Controller Status (Adv Control Status)

Command Inputs

Some signals can come from multiple sources. Use the *Command Inputs* parameter to determine which source(s) is(are) active at any time. The *Command Inputs* parameters are bitmasks. Each bit represents each type of source.

TABLE 3-32. COMMAND INPUTS BITMASK

BIT	SOURCE
0	Hardware input
1	Configurable input (page 3-10)

2	PCCNet device (page 1-4)
3	Modbus network (page 1-4)
4	System bus
7	Any other source

For example, if a signal is active because the hardware input is active and the Modbus input is active, the *Command Inputs* value is 9 (00001001).

If a signal does not support a particular type of source, the bit value for the source is 0.

Each label is described in the following table.

TABLE 3-33. CONTROLLER STATUS (ADV CONTROL STATUS)

NAME	DESCRIPTION
Underfreq Thld	The frequency trip threshold for the load dump underfrequency condition Parameter: Load Dump Underfrequency Threshold. Allowed values: 0~90 Hz.
Start Countdn	Time remaining until start is initiated Parameter: Start Countdown. Allowed values: 0~300 seconds.
Stop Countdn	Time remaining until genset stops Parameter: Stop Countdown. Allowed values: 0~5000 seconds.
Time No Load	Amount of time the genset has run at no load Parameter: Time At No Load. Allowed values: 0~600 seconds.
Time Rtd Cldn	Amount of time spend in Rated Cooldown Parameter: Time at Rated Cooldown. Allowed values: 0~5000 seconds.
Exer Time Rem	Time remaining until exercise stop sequence begins Parameter: Exercise Time Remaining. Allowed values: 0~25 hours.
Config In #1	Configurable Input #1 input software state status. Gives software Inactive/Active state Parameter: Configurable Input #1 Switch. Allowed values: Inactive, Active.
Config In #2	Configurable Input #2 input software state status. Gives software Inactive/Active state Parameter: Configurable Input #2 Switch. Allowed values: Inactive, Active.
Config In #13	Configurable Input #13 input software state status. Gives software Inactive/Active state Parameter: Configurable Input #13 Switch. Allowed values: Inactive, Active.

NAME	DESCRIPTION
Config In #14	Configurable Input #14 input software state status. Gives software Inactive/Active state Parameter: Configurable Input #14 Switch. Allowed values: Inactive, Active.
Config In #5	This is the status of the Configurable Input #5. Parameter: Coolant Level/Configurable Input #5 Switch. Allowed values: Inactive, Active.
Config In #6	This is the status of the Configurable Input #6. Parameter: Low Fuel/Configurable Input #6 Switch. Allowed values: Inactive, Active.
Config In #10	This is the status of the Configurable Input #10. Parameter: Fault Reset/Configurable Input #10 Switch. Allowed values: Inactive, Active.
Config In #11	This is the status of the Configurable Input #11. Parameter: Start Type/Configurable Input #11 Switch. Allowed values: Inactive, Active.
Config In #12	This is the status of the Configurable Input #12. Parameter: Rupture Basin/Configurable Input #12 Switch. Allowed values: Inactive, Active.
Config Out #1	Indicates if the output's status is Inactive or Active Parameter: Configurable Output #1 Status. Allowed values: Inactive, Active.
Config Out #2	Indicates if the output's status is Inactive or Active Parameter: Configurable Output #2 Status. Allowed values: Inactive, Active.
Config Out #3	Indicates if the output's status is Inactive or Active Parameter: Configurable Output #3 Status. Allowed values: Inactive, Active.
Config Out #4	Indicates if the output's status is Inactive or Active Parameter: Configurable Output #4 Status. Allowed values: Inactive, Active.
Config Out #5	Indicates if the output's status is Inactive or Active Parameter: Ready To Load /Configurable Output #5 Status. Allowed values: Inactive, Active.
Config Out #6	Indicates if the output's status is Inactive or Active Parameter: Oil Priming Pump / Configurable Output #6 Status. Allowed values: Inactive, Active.
Config Out #7	Indicates if the output's status is Inactive or Active Parameter: Local Status / Configurable Output #7 Status. Allowed values: Inactive, Active.
Config Out #8	Indicates if the output's status is Inactive or Active Parameter: Glow Plug / Configurable Output #8 Status. Allowed values: Inactive, Active.
Config Out #10	Indicates if the output's status is Inactive or Active Parameter: Delayed Off / Configurable Output #10 Status. Allowed values: Inactive, Active.
Config Out #11	Indicates if the output's status is Inactive or Active Parameter: Load Dump / Configurable Output #11 Status. Allowed values: Inactive, Active.
Auto Switch	Status of the Auto Switch Input Parameter: Auto Switch. Allowed values: Inactive, Active.
Batt Chrgr Fail Sw	Battery Charger Failed Switch function output status; gives software Inactive/Active state Parameter: Battery Charger Failed Switch. Allowed values: Inactive, Active.

NAME	DESCRIPTION
High Alt Temp	High Alt Temp Switch function output status. Gives software Inactive/Active state Parameter: High Alt Temp Switch. Allowed values: Inactive, Active.
Low Coolant #2 Sw	Low Coolant #2 Switch function output status. Gives software Inactive/Active state Parameter: Low Coolant #2 Switch. Allowed values: Inactive, Active.
Low Eng Temp	Low Engine Temperature Switch function output status. Gives software Inactive/Active state Parameter: Low Engine Temperature Switch. Allowed values: Inactive, Active.
Lo Fuel Dy Tnk	Low Fuel In Day Tank Switch function output status. Gives software Inactive/Active state Parameter: Low Fuel In Day Tank Switch. Allowed values: Inactive, Active.
Alt Temp Time	Fault time delay from switch input. Parameter: High Alternator Temperature Switch Time.
Rem Start Inp	Bitmask to show the inputs to the Command output which are currently on Parameter: Remote Start Command Inputs.
Start Type In	Bitmask to show the inputs to the Command output which are currently on Parameter: Start Type Command Inputs.
Battle Short In	Indicates which of the battle short inputs are active. Parameter: Battle Short Command Inputs.
Coolant Level Sw	Coolant Level input software state status. Gives software Inactive/Active state Parameter: Coolant Level Switch.
Low Fuel Sw	Low Fuel input software state status. Gives software Inactive/Active state Parameter: Low Fuel Switch.
Start Type Sw	Start Type input software state status. Gives software Inactive/Active state Parameter: Start Type Switch.
Rupt Basin Sw	Rupture Basin input software state status. Gives software Inactive/Active state Parameter: Rupture Basin Switch.

Engine Status (Adv Engine Status)

Each label is described in the following table.

TABLE 3-34. ENGINE STATUS (ADV ENGINE STATUS)

NAME	DESCRIPTION
WIF Ind	Water in Fuel Indication Parameter: Water in Fuel Indicator. Allowed values: No, Yes.
Turbo 1 Spd	Monitor point for the Turbocharger 1 Speed Parameter: Turbocharger 1 Speed. Allowed values: 0~257000 rpm.
Boost 2 Pres	Monitor point for the Turbocharger 2 Boost Pressure Parameter: Turbocharger 2 Boost Pressure. Allowed values: 0~1160 psi.
Gov Strt Ramp	The state of the speed reference ramp Parameter: Speed Ramp State. Allowed values: Ramp Off, Ramp On.
Prelube Stat	The monitor point for the prelube state. Parameter: Prelube State. Allowed values: Complete, Armed, Prelube Output ON, Prelube Output OFF, Enable Crank.

NAME	DESCRIPTION
PreFil Oil Press	Monitor point for the Pre-Filter Oil Pressure Parameter: Pre-Filter Oil Pressure. Allowed values: 0~145 psi.
PstFil Oil Press	Monitor point for the Post-Filter Oil Pressure Parameter: Post-Filter Oil Pressure. Allowed values: 0~145 psi.
Bat Char Volt	The Battery Charger Alternator Flash Voltage after all scaling and validity checks. Parameter: Battery Charger Alternator Flash Voltage.
Manf Temp 2	Monitor point for the Intake Manifold 2 Temperature Parameter: Intake Manifold 2 Temperature. Allowed values: -40~410 degF.
Manf Temp 3	Monitor point for the Intake Manifold 3 Temperature Parameter: Intake Manifold 3 Temperature. Allowed values: -40~410 degF.
Manf Temp 4	Monitor point for the Intake Manifold 4 Temperature Parameter: Intake Manifold 4 Temperature. Allowed values: -40~410 degF.
Exhaust Port Temperature	
Port 1	Monitor point for the Exhaust Port 1 Temperature Parameter: Exhaust Port 1 Temperature. Allowed values: -459~3155 degF.
Port 2	Monitor point for the Exhaust Port 2 Temperature Parameter: Exhaust Port 2 Temperature. Allowed values: -460~3155 degF.
Port 3	Monitor point for the Exhaust Port 3 Temperature Parameter: Exhaust Port 3 Temperature. Allowed values: -460~3155 degF.
Port 4	Monitor point for the Exhaust Port 4 Temperature Parameter: Exhaust Port 4 Temperature. Allowed values: -460~3155 degF.
Port 5	Monitor point for the Exhaust Port 5 Temperature Parameter: Exhaust Port 5 Temperature. Allowed values: -460~3155 degF.
Port 6	Monitor point for the Exhaust Port 6 Temperature Parameter: Exhaust Port 6 Temperature. Allowed values: -460~3155 degF.
Port 7	Monitor point for the Exhaust Port 7 Temperature Parameter: Exhaust Port 7 Temperature. Allowed values: -460~3155 degF.
Port 8	Monitor point for the Exhaust Port 8 Temperature Parameter: Exhaust Port 8 Temperature. Allowed values: -460~3155 degF.
Port 9	Monitor point for the Exhaust Port 9 Temperature Parameter: Exhaust Port 9 Temperature. Allowed values: -460~3155 degF.
Port 10	Monitor point for the Exhaust Port 10 Temperature Parameter: Exhaust Port 10 Temperature. Allowed values: -460~3155 degF.
Port 11	Monitor point for the Exhaust Port 11 Temperature Parameter: Exhaust Port 11 Temperature. Allowed values: -460~3155 degF.
Port 12	Monitor point for the Exhaust Port 12 Temperature Parameter: Exhaust Port 12 Temperature. Allowed values: -460~3155 degF.
Port 13	Monitor point for the Exhaust Port 13 Temperature Parameter: Exhaust Port 13 Temperature. Allowed values: -460~3155 degF.

NAME	DESCRIPTION
Port 14	Monitor point for the Exhaust Port 14 Temperature Parameter: Exhaust Port 14 Temperature. Allowed values: -460~3155 degF.
Port 15	Monitor point for the Exhaust Port 15 Temperature Parameter: Exhaust Port 15 Temperature. Allowed values: -460~3155 degF.
Port 16	Monitor point for the Exhaust Port 16 Temperature Parameter: Exhaust Port 16 Temperature. Allowed values: -460~3155 degF.
Port 17	Monitor point for the Exhaust Port 17 Temperature Parameter: Exhaust Port 17 Temperature. Allowed values: -460~3155 degF.
Port 18	Monitor point for the Exhaust Port 18 Temperature Parameter: Exhaust Port 18 Temperature. Allowed values: -460~3155 degF.
Port 19	Monitor point for the Exhaust Port 19 Temperature Parameter: Exhaust Port 19 Temperature. Allowed values: -460~3155 degF.
Port 20	Monitor point for the Exhaust Port 20 Temperature Parameter: Exhaust Port 20 Temperature. Allowed values: -460~3155 degF.

PARALLELING**LOAD DEMAND STATUS**

Use this screen to select one of these screens.

Paralleling Status

This is reserved for future use.

Paralleling Setup

This is reserved for future use.

This is reserved for future use.

POWER STATUS

This is reserved for future use.



THIS PAGE LEFT INTENTIONALLY BLANK



4. Parameters

PARAMETERS THAT ARE NOT AVAILABLE IN THE OPERATOR PANEL

This section lists the parameters that may be mentioned in this manual but are not available in the Operator Panel. Many of these parameters can be viewed or adjusted using InPower or Modbus.

Note: The default values might not be the same in your genset. The values shown are based on the original settings for the PCC and may be adjusted when the genset is designed, when the genset is installed, or by other operators after installation.

TABLE 4-1. PARAMETERS THAT ARE NOT AVAILABLE IN THE OPERATOR PANEL

PARAMETER	INPOWER	MODBUS	DEFAULT VALUE	DESCRIPTION
Auto Switch Active State Selection	Yes		Active Closed	Auto switch input software logic state inversion bypass control
AVR Enable	Yes		Enabled	Enables or disables the AVR
Battery Charger AC Failure (HMI113)		Yes		Monitor point for the battery charger failure input from the PCCNET Annunciator.
Battle Short Switch (Modbus)	Yes	Yes	Inactive	Trim to enable Battle Short via Modbus.
Derate Request		Yes	0%	The requested % derate from the derate request logic
Genset Exercise Time	Yes	Yes	0 Hours	Sets the total exercise time not including warmup at idle or idle cooldown time
Governor Enable Engine Speed			1100 rpm	Sets the threshold to transition from open loop governor control to closed loop
Instantaneous High AC Voltage Threshold	Yes		130%	Percent of desired voltage at which Instantaneous High AC Voltage fault becomes active.
Local E-Stop Active State Selection	Yes		Active Open	Local E-stop input software logic state inversion bypass control
Low Coolant Level (HMI113)	Yes	Yes		Monitor point for the Low Coolant Level input from the PCCnet Annunciator.
Low Fuel Level (HMI113)	Yes	Yes		Monitor point for the Low Fuel Level input from the PCCnet Annunciator.
Manual Switch Active State	Yes		Active Closed	Manual input software logic state inversion bypass control
Manual Warmup Bypass	Yes	Yes	Normal	Use to command idle speed or to bypass idle warmup during a manual run
Max Setup Mode Time	Yes	Yes	600 Seconds	Max time allowed in Setup Mode.
Remote E-Stop Active State Selection	Yes		Active Open	Remote E-stop input software logic state inversion bypass control

PARAMETER	INPOWER	MODBUS	DEFAULT VALUE	DESCRIPTION
Remote Start Switch Active State Selection	Yes		Active Closed	Remote Start input software logic state inversion bypass control
Setup Mode Timer	Yes	Yes		Time spent in Setup Mode.

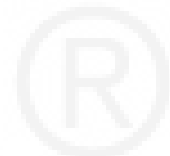

5. Troubleshooting

In this section, *italics* are used to identify a specific parameter by name.

SAFETY CONSIDERATIONS

High voltages are present when the set is running. Do not open the generator output box while the set is running.

⚠WARNING *Contacting high voltage components can cause electrocution, resulting in severe personal injury or death. Keep the output box covers in place during troubleshooting.*

When troubleshooting a set that is shut down, make certain the genset cannot be accidentally restarted. This includes, but is not limited to, these steps.

1. Put the PCC in Off mode (page 2-8).
2. Push one of the Emergency Stop buttons, and wait thirty seconds.
3. Isolate any power supplies (for example, for heaters or pumps) to the genset. This does not include the battery or battery charger, which are isolated in the next steps.
4. Turn off and remove power from the battery charger, if there is one.
5. **MAKE CERTAIN EXPLOSIVE BATTERY GASES ARE DISPELLED FROM BATTERY COMPARTMENT**, and then remove the negative (-) battery cable from the set starting battery.
6. Disable the starter, if it is possible for the genset to start without the battery (for example, an air starter).
7. Display a suitable “Maintenance In Progress” sign prominently.
8. Follow the appropriate lockout/tagout procedures.

⚠WARNING *Accidental starting of the genset during troubleshooting can cause severe personal injury or death. Disable the genset (see above) before troubleshooting.*

Note: Before servicing the PCC, it is recommended that all settings be recorded. This makes sure of correct and complete readjustment of the PCC in the event that all previous entries are lost during servicing.

Read **Safety Precautions**, and carefully observe all of the instructions and precautions in this manual.

TYPES OF EVENTS/FAULTS

The PCC generates these types of events/faults.

Shutdown Faults

The PCC generates shutdown faults to prevent damage to the genset.

When the PCC generates a shutdown fault, the shutdown fault becomes active. The PCC initiates a Shutdown Without Cooldown sequence (page 2-18).

Active shutdown faults appear in the Shutdown Faults screen (page 3-5). In addition, the PCC provides these indications as long as there is an active shutdown fault.

- The Shutdown LED (page 2-6) on the Operator Panel is on.
- Event 1541 (Common Shutdown) is active.
- Event 1483 (Common Alarm) is active.

You cannot start the genset until you clear the shutdown fault. Follow these steps to clear a shutdown fault.

1. Correct the condition(s) that caused the fault.
2. Make sure the emergency stop buttons are inactive, and change the PCC to Off mode (page 2-8).

Note: If *Enable Remote Fault Reset* is set to Enable, you can also clear shutdown faults in Auto mode. In this case, change the PCC to Auto mode (page 2-8), and make sure the exercise signal (page 2-8) and the remote start signal (page 2-9) are inactive. The PCC generates event 2941 (Remote Shutdown Fault Reset Occurrence) when shutdown faults are reset in Auto mode.

3. Activate the fault reset signal (page 5-3).

Faults that have been cleared appear in the Fault History screen (page 3-6).

Critical Shutdown Faults vs. Non-critical Shutdown Faults

The PCC always shuts down the genset when a critical shutdown fault occurs. Non-critical shutdown faults do not prevent the PCC from starting or running the genset when one of these features is active.

- Battle Short mode (page 5-3)
- Delayed Shutdown (page 5-4)

Table 5-1 identifies the critical shutdown faults.

TABLE 5-1. CRITICAL SHUTDOWN FAULTS

EVENT/FAULT CODE	DESCRIPTION
115	Eng Crank Sensor Error
234	Crankshaft Speed High
236	Both Engine Speed Signals Lost
359	Fail To Start
781	CAN data link failure
1245	Engine Shutdown Fault
1336	Cooldown Complete
1433	Local Emergency Stop
1434	Remote Emergency Stop
1438	Fail To Crank
1992	Crankshaft Sensor High
2335	AC Voltage Sensing Lost (Excitation Fault)
2914	Genset AC Meter Failed

All other shutdown faults are non-critical shutdown faults. The PCC still provides the usual indications that a shutdown fault has occurred, even if it overrides a non-critical shutdown fault.

Warning Faults

The PCC generates warning faults to warn the operator when unsafe conditions are occurring.

When the PCC generates a warning fault, the warning fault becomes active. However, active warning faults have no effect on genset operation. The genset can start, continue running, and stop as usual.

Active warning faults appear in the Warning Faults screen (page 3-5). In addition, the PCC provides these indications as long as there is an active warning fault.

- The Warning LED (page 2-6) on the Operator Panel is on.
- Event 1540 (Common Warning) is active.
- Event 1483 (Common Alarm) is active.

Follow these steps to clear a warning fault.

1. Correct the condition(s) that caused the fault.
2. Activate the fault reset signal (page 5-3).

Faults that have been cleared appear in the Fault History screen (page 3-6).

Derate Events

Derate events are warning faults in which the PCC also requests a reduction in the kW output level of the genset.

It is up to external devices to reduce the load. The PCC does not do anything else to reduce the kW output level.

If a derate event is active, *Derate Request*¹⁹ is the percentage of the current kW output level the PCC would like to have removed. In addition, if *Load Dump / Configurable Output #11 Output Function Pointer_* is set to Default, the Load Dump connection is active.

Events

The PCC generates events to notify external devices when certain conditions are met. The PCC may send notifications any of these ways.

- Configurable outputs (page 3-12)
- PCCNet devices (page 1-4) (For example, events might control a LED or a configurable output on a PCCNet device.)

It is up to the external devices to respond to an event when they are notified about one. Events do not appear in any screen in the Operator Panel.

FAULT RESET SIGNAL

This signal may come from any of these sources.

- PCC Fault Reset connection (typically, the Reset button on the Operator Panel)
- Reset button (page 2-6) on the Operator Panel
- Modbus networks (page 1-4)
- PC-based service tool, such as InPower (page 1-6)

This signal becomes active for one second when any of these sources changes from inactive to active. Then, the signal remains inactive until any of these sources changes from inactive to active again.

BATTLE SHORT MODE

Battle Short mode is used to satisfy local code requirements. While Battle Short mode is active, the PCC ignores non-critical shutdown faults (page 5-2) and continues to run the genset. Otherwise, genset operation remains the same.

⚠ *WARNING Use of Battle Short mode can cause a fire or electrical hazard, resulting in severe personal injury, death, and/or property and equipment damage. This mode must only be used during supervised, temporary operation of the genset.*

Battle Short mode must be set up at the factory or by an authorized service representative. Contact your local distributor for assistance.

Battle Short mode is active only when all of these conditions are met.

19. This parameter is not available in the Operator Panel. See Table 4-1 (page 4-1).

- *Battle Short Enable* is set to Enable.
- The ECM is set to enable Battle Short mode (Core 2 ECMs only).
- The Battle Short Switch or *Battle Short Switch (Modbus)*²⁰ is active.

The PCC generates warning fault 2942 (Shutdown Override Fail) if the Battle Short Switch is active but any of the other conditions are not met.

Battle Short mode is not a distinct mode of operation (page 2-8). The PCC is still in Off mode, Manual mode, or Auto mode while Battle Short mode is active. The PCC still follows the appropriate sequence of operation (page 2-11) to start the genset and to stop the genset.

The PCC generates warning fault 1131 (Battle Short Active) as long as Battle Short mode is active.

While Battle Short mode is active, the PCC ignores most shutdown faults and only initiates a Shutdown Without Cooldown sequence (page 2-18) if a critical shutdown fault (page 5-2) occurs.

When the PCC overrides a shutdown fault, it generates warning fault 1416 (Fail To Shut Down) after *Fail To Shutdown Delay* as long as Battle Short mode remains active. It also turns on the Shutdown LED.

⚠️WARNING *The faults that are overridden in Battle Short mode can affect genset performance and might cause permanent engine, alternator, or connected equipment damage. All shutdown faults, including those overridden in Battle Short mode, must be acted upon immediately to ensure the safety and well-being of the operator and the genset.*

Note: Any damage caused to the genset as a direct result of running in Battle Short mode is not covered by the warranty.

DELAYED SHUTDOWN

The PCC provides advance warning of an impending shutdown if these conditions are met.

- *Delayed Shutdown Enable* is set to Enable.
- The ECM is set to enable Battle Short mode (Core 2 ECMs only).
- A non-critical shutdown fault (page 5-2) occurs, and there are no critical shutdown faults.

When these conditions are met, the PCC generates warning fault 1124 (Delayed Shutdown) and waits *Delayed Shutdown Time Delay* before it shuts down the genset.

EVENT/FAULT LIST

These tables identify the faults and events the PCC can generate.

- Table 5-2. Shutdown faults.
- Table 5-3. Derate events.
- Table 5-4. Warning faults.
- Table 5-5. Events.

Note: Your genset may not be able to generate some faults or events.

These tables are organized by the default response/severity of each event/fault code. You can use InPower to raise the response/severity of an event or fault. For example, you can change an event to a warning fault or a warning fault to a shutdown fault. You cannot set the response/severity of an event or fault lower than its default value, and you cannot change the severity of any fault or event with an asterisk(*).

TABLE 5-2. SHUTDOWN FAULTS

EVENT/FAULT CODE	DESCRIPTION
111	Engine Control Module Critical Internal Failure
115	Eng Crank Sensor Error

20. This parameter is not available in the Operator Panel. See Table 4-1 (page 4-1).

EVENT/FAULT CODE	DESCRIPTION
151	High Coolant Temp
155	High Intake Manf 1 Temp
214	High Oil 1 Temp
228	Low Coolant Pressure
234	Crankshaft Speed High
235	Low Coolant Level
236	Both Engine Speed Signals Lost
254	FSO_PWM_HIGH_CONTROL_ERROR
266	High Fuel Temperature
342	Calibration Code Fail
359	Fail To Start
415	Low Oil Rifle Press
449	Inj Metering 1 Press High
556	Crankcase Press High
781	CAN data link failure
783	Intake Manf 1 Rate Error
1244	Engine Normal Shutdown
1245	Engine Shutdown Fault
1257	Ctrl Mod ID In State Fail
1336	Cooldown Complete
1433	Local Emergency Stop
1434	Remote Emergency Stop
1438	Fail To Crank
1443	Dead Battery
1445	Short Circuit
1446	High AC Voltage
1447	Low AC Voltage
1448	Under frequency
1459	Reverse Power
1461	Loss of Field (Reverse KVAR)
1472	Over Current
1517	Failed Module Shutdown
1918	Fuel Level Low
1992	Crankshaft Sensor High
2335	AC Voltage Sensing Lost (Excitation Fault)
2336	Bad Checksum
2661	At Least One Unacknowledged Most Severe Fault - Condition Exists
2814	Genset CT Ratio Low
2816	Genset PT Ratio Low
2896	Critical PCCnet Dev Fail
2914	Genset AC Meter Failed
2972	Field Overload

TABLE 5-3. DERATE EVENTS

EVENT/FAULT CODE	DESCRIPTION
146	Pre-High Engine Coolant Temperature
421	High Oil Temperature
488	High Intake Manf 1 Temp
1243	Engine Derated

TABLE 5-4. WARNING FAULTS

EVENT/FAULT CODE	DESCRIPTION
122	Manifold 1 Press High
123	Manifold 1 Press Low
124	Manifold 1 Press High

EVENT/FAULT CODE	DESCRIPTION
135	High Oil Rifle 1 Pressure
141	Low Oil Rifle 1 Pressure
143	Low Oil Rifle Pressure
144	High Coolant 1 Temp
145	Low Coolant 1 Temp
153	High Intake Manf 1 Temp
154	Low Intake Manf 1 Temp
187	Sensor Supply 2 Low
195	High Coolant 1 Level
196	Low Coolant 1 Level
197	Low Coolant Level
212	High Oil 1 Temperature
213	Low Oil 1 Temperature
221	Air Pressure Sensor High
222	Air Pressure Sensor Low
223	Oil Burn Valve Sol Low
224	Oil Burn Valve Sol High
227	Sensor Supply 2 Low
231	High Coolant Pressure
232	Low Coolant Pressure
238	Sensor Supply 3 Low
239	Main Supply High
245	Fan Control Low
261	High Fuel Temperature
263	High Fuel 1 Temperature
265	Low Fuel 1 Temperature
271	Low Fuel Pump Press
272	High Fuel Pump Press
281	Cylinder Press Imbalance
285	CAN Mux PGN Rate Err
286	CAN Mux Calibration Err
295	Key On Air Press Error
322	Inj 1 Solenoid Low Curr
323	Inj 5 Solenoid Low Curr
324	Inj 3 Solenoid Low Curr
325	Inj 6 Solenoid Low Curr
331	Inj 2 Solenoid Low Curr
332	Inj 4 Solenoid Low Curr
343	ECM Hardware Failure
351	Injector Supply Failure
352	Sensor Supply 1 Low
386	Sensor Supply 1 High
418	High H2O In Fuel
422	Coolant Level Data Error
425	Oil Temperature Error
427	CAN Data Link Degraded
435	Oil Press Switch Error
441	Low Battery 1 Voltage
442	High Battery 1 Voltage
451	Inj Metering 1 Press High
452	Inj Metering 1 Press Low
546	Fuel Delivery Press High
547	Fuel Delivery Press Low

EVENT/FAULT CODE	DESCRIPTION
553	APC Pressure High
554	APC Pressure Error
559	Inj Metering 1 Press Low
611	Engine Hot Shut Down
689	Crankshaft Speed Error
697	ECM Temperature High
698	ECM Temperature Low
731	Crankshaft Mech Misalign
781	CAN Data Link Failure
782	SAE J1939 Data Link 2 Engine Network No Data Received – Condition Exists
1124	Delayed Shutdown
1131	Battle Short Active
1132	Controlled Shutdown
1246	Unknown Engine Fault
1248	Engine Warning
1256	Ctrl Mod ID In State Error
1357	Oil Remote Level Low
1376	Camshaft Speed Error
1411	High Out Freq Adjust Pot
1412	High Droop Adjust Pot
1416	Fail To Shutdown
1417	Power Down Failure
1418	High Gain Adjust Pot
1427	Overspeed Relay Error
1428	LOP Relay Error
1429	HET Relay Error
1431	Pre-LOP Relay Error
1432	Pre-HET Relay Error
1435	Low Coolant Temperature
1439	Low Day Tank Fuel Sw
1441	Low Fuel Level
1442	Weak Battery
1444	Overload
1449	Overfrequency
1464*	Load Dump Fault
1469	Speed/Hz Mismatch
1471	Over Current
1518	Failed Module Warning
1548	Inj 7 Solenoid Low Curr
1549	Inj 8 Solenoid Low Curr
1551	Inj 10 Solenoid Low Curr
1552	Inj 11 Solenoid Low Curr
1553	Inj 12 Solenoid Low Curr
1554	Inj 13 Solenoid Low Curr
1555	Inj 14 Solenoid Low Curr
1556	Inj 15 Solenoid Low Curr
1557	Inj 16 Solenoid Low Curr
1597	ECM Device/Component
1622	Inj 9 Solenoid Low Curr
1689	Real Time Clock Power
1695	Sensor Supply 5 High
1696	Sensor Supply 5 Low
1843	Crankcase Press High

EVENT/FAULT CODE	DESCRIPTION
1844	Crankcase Press Low
1845	H2O In Fuel Sens High
1846	H2O In Fuel Sense Low
1852	Pre-High H2O In Fuel
1853	Annunciator Input 1 Fault
1854	Annunciator Input 2 Fault
1855	Annunciator Input 3 Fault
1891	Change Oil
1893	CAN EGR Valve Comm
1894	CAN VGT Comm Error
1896	EGR DL Valve Stuck
1899	Low EGR Dif Pressure
1911	Inj Metering 1 Press High
1917	Fuel Level High
1933	High EGR Data Link Volt
1934	Low EGR Data Link Volt
1935	EGR DL Cmd Source Err
1942	THD AZ Error
1944	HMI 113 Out Config Error
1961	High EGR DL EDU Temp
1974	Crankcase Press High
2185	Sensor Supply 4 High
2186	Sensor Supply 4 Low
2215	Fuel Pump Press Low
2249	APC 2 Pressure Low
2261	Fuel Pump Press High
2262	Fuel Pump Press Low
2265	High Fuel Lift Pump Volt
2266	Low Fuel Lift Pump Volt
2292	APC Flow High
2293	APC Flow Low
2311	EFI Control Valve Fail
2342	Too Long In Idle
2377	High Fan Control Voltage
2539	High Voltage Bias
2541	Low Voltage Bias
2545	Keysw Reset Required
2555	Low GHC 1 Voltage
2556	High GHC 1 Voltage
2653	Exhaust St 2 Temp High
2657	Exhaust St 1 Temp High
2678	Charging Alternator Fail
2815	Genset CT Ratio High
2817	Genset PT Ratio High
2895	PCCnet Device Failed
2922	High Genset Neutral Curr
2934	High Ambient Temp
2935	Low Ambient Temp
2936	Fuel Level High
2937	Fuel Level Low
2938	Ground Fault Switch
2939	MODBUS Failure
2942	Shutdown Override Fail

EVENT/FAULT CODE	DESCRIPTION
2943	Manual Sw Config Fail
2944	Auto Switch Config Fail
2945	Rupture Basin Switch
2946	Exhaust St 2 Temp Low
2947	Exhaust St 1 Temp Low
2948	Exhaust St 2 Temp High
2949	Exhaust St 1 Temp High
2951	Alternator 1 Temp High
2952	Alternator 1 Temp Low
2953	Alternator 1 Temp High
2954	Alternator 2 Temp High
2955	Alternator 2 Temp Low
2956	Alternator 2 Temp High
2957	Alternator 3 Temp High
2958	Alternator 3 Temp Low
2959	Alternator 3 Temp High
2971	Test/Exercise Fault
2973	Charge Press IR Error
2977	Low Coolant Level 2 Sw
2978	Low Intake Manf 1 Temp
2979	High Alternator Temp Sw
2981	High Drive Bearing Temp
2982	Low Drive Bearing Temp
2983	High Drive Bearing Temp
2984	High Free Bearing Temp
2985	Low Free Bearing Temp
2986	High Free Bearing Temp
2992	High Intake Manf 1 Temp
2993	Battery Charger Sw Fail

TABLE 5-5. EVENTS

EVENT/FAULT CODE	DESCRIPTION
1122	Rated to Idle Delay
1312	Configurable Input #2
1317	Configurable Input #13
1318	Configurable Input #14
1463*	Not In Auto
1465*	Ready to Load
1483*	Common Alarm
1540	Common Warning
1541	Common Shutdown
1573	Configurable Input #1
2941	Remote Shutdown Fault Reset Occurrence

TROUBLESHOOTING PROCEDURES

Read **Safety Precautions**, and carefully observe all of the instructions and precautions in this manual.

When the PCC generates a fault, follow these steps to try to clear it.

If the Shutdown LED is on,

1. Make sure the emergency stop buttons are inactive.
2. Change the PCC to Off mode (page 2-8).
3. Activate the fault reset signal (page 5-3).

If the Shutdown LED is off, just activate the fault reset signal (page 5-3).

If the fault is not cleared, see **How to Obtain Service** (page 5-10).

HOW TO OBTAIN SERVICE

At Cummins Power Generation, we want to deliver more than just good service. The process starts with an accurate description of generator set information, such as fault code numbers and troubleshooting procedures performed, without which no repair can possibly be performed accurately.

Before contacting your local distributor, locate the name plate on the side of the generator output box, and have the following information available.

Model of Control _____

Control Part Number and Serial Number _____

Describe the control issue _____

Are there any fault codes on the operator panel? _____

If so, list the fault codes on the operator panel. _____

To find the closest distributor,

1. Go to <http://www.cumminspower.com>.
2. Click on "Distributor Locator".

⚠WARNING *Incorrect service or replacement of parts can result in severe personal injury, death, and/or equipment damage. Service personnel must be trained and experienced to perform electri-*

cal and mechanical service. Read Safety Precautions, and carefully observe all of the instructions and precautions in this manual.



THIS PAGE LEFT INTENTIONALLY BLANK



Cummins



Cummins Power Generation

1400 73rd Ave. NE
Minneapolis, MN 55432 USA

Phone 1 763 574 5000

Toll-free 1 800 888 6626

Fax 1 763 574 5298

Email ask.powergen@cummins.com

www.cumminspower.com

Cummins®, the "C" logo, and "Our energy working for you." are trademarks of Cummins Inc.

©2008 Cummins Power Generation, Inc. All rights reserved.

