

OPERATOR'S MANUA AND PARTS CATALOG

FOR

EK-EM

SERIES

ELECTRIC GENERATING SETS

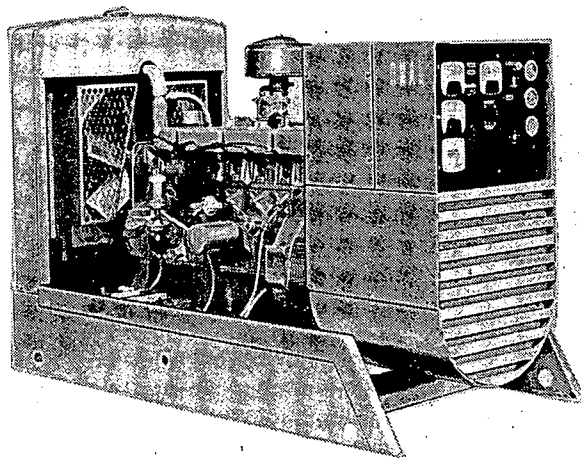

Page 11

BEGIN SPEC. C

FILE COPY
LITERATURE SECTION
RETURN TO FILE
TECH. PUB. DEPT.

SAFETY PRE.

TABLE OF CONTENTS

TITLE	PAGE
Introduction	1
Safety Precautions	2
Specifications	4
Description	9
Installation	13
Operation	22
General Maintenance	27
Parts Catalog	35

The need for an international standard of measurement has been increased by today's improved communication and transportation between countries.

This has prompted formation of modernized metrics known as the International System of Units, officially abbreviated SI.

ONAN products appear on the world market, therefore both metric and the present American system of units (CU) will be found in this manual.

To assist in familiarization, refer to the following terms.

TERM	METRIC	ENGLISH
Length	millimetre (mm)	Inch (in)
Pressure	kilopascals (kPa)	pounds per square inch (PSI)
Mass (Weight)	kilogram (kg)	pound (lb)
Volume (Liquid)	litre	gallon (gal)
Power	kilowatt	horsepower (HP)
Frequency	hertz (Hz)	cycles per second (CPS)
Energy	Joules (J)	BTU
Battery Capacity	Coulomb (C)	Ampere Hour (AH)
Revolutions per Minute	r/min	rpm
Temperature	Celsius (°C)	Fahrenheit (°F)

The customary unit of Brake Horsepower (BHP) becomes kilowatts (kW) when converted to SI metric units. This kW rating should not be confused with the kW rating of the generator which will always be lower due to losses inherent with any electrical induction device.

WARNING

TO AVOID POSSIBLE PERSONAL INJURY OR EQUIPMENT DAMAGE, A QUALIFIED ELECTRICIAN OR AN AUTHORIZED SERVICE REPRESENTATIVE MUST PERFORM INSTALLATION AND ALL SERVICE.

TABLE OF CONTENTS

INTRODUCTION

FOREWORD

This manual is applicable to the EK/EM Series electric generating sets each consisting of an ONAN UR generator, driven by a Ford C5PG Gas/Gaso Engine. See *SPECIFICATIONS* for generator sizes.

The manual is divided into two sections.

Section 1 provides information in installation, operation and troubleshooting.

Section 2 is a Parts Catalog for ONAN optional and standard equipment.

The manual should be used in conjunction with the Ford engine manual, for specific engine information.

MODEL IDENTIFICATION

Identify your model by referring to the MODEL and SPECIFICATION NO. as shown on the Onan nameplate. Electrical characteristics are shown on the lower portion of the nameplate.

<u>30.0</u>	<u>EK</u>	<u>15R</u>	<u>/</u>	<u>1</u>	<u>G</u>
1	2	3		4	5

1. Indicates Kilowatt rating (30 kW).
2. Factory code for SERIES identification.
3. 15 = 60 Hz. Reconnectible
515 = 50 Hz. Reconnectible
R—Indicates remote starting feature.
4. Factory code for designating optional equipment.
5. Specification letter. (Advances when factory makes production modifications.)

When contacting a dealer or the factory regarding the set, always mention the complete Model, Spec No. and Serial No. as given on the Onan nameplate. This nameplate information is necessary to properly identify your unit among the many manufactured. Refer to the engine nameplate when requesting information from its manufacturer. The Onan nameplate is located on the right side of the generator; the Ford nameplate is on the right hand side on the valve cover.

Left side and right side are considered when viewed from the engine or front end of the generator set.

WARNING Onan uses this symbol throughout this manual to warn of possible personal injury.

CAUTION This symbol refers to possible equipment damage.

EXHAUST WARNING

INTRO.

SAFETY PRECAUTIONS

Throughout this manual you will find eye-catching flags containing Warnings and Cautions. These will alert you to conditions that could result in danger to you or the equipment, if the notice is ignored.

ONAN recommends that you read your manual and become thoroughly acquainted with it and your equipment before you start your unit. The accumulated experience of ONAN engineers is available to you, enabling you to operate your set in the most efficient and safest manner possible. These recommendations and the following safety precautions are for your protection. Study and know them!

REMEMBER. Most accidents are caused by failure to follow simple and fundamental safety rules or precautions.

Most accidents can be prevented!

KNOW YOUR MANUAL—KNOW YOUR EQUIPMENT

WARNING

Set forth below are a number of potential hazards which could result in some degree of personal injury. The suggested procedures should be adhered to.

General

- Keep your electric generating set and the surrounding area clean and free from obstructions. Remove all oil deposits; keep the floor clean and dry.
- Provide appropriate fire extinguishers and install them in convenient locations. Consult your local fire department for the correct type of extinguisher to use. Do not use foam on electrical fires. Use extinguisher rated ABC by NFPA.
- Make sure that all fasteners on the generating set are secure. Tighten supports and clamps, keep guards in position over fans, driving belts, etc.
- Do not wear loose clothing in the vicinity of moving parts, or jewelry while working on electrical equipment. Loose clothing and jewelry can become caught in moving parts. Jewelry can short out electrical contacts; cause shock or burning.
- If necessary to make adjustments while the unit is running, use extreme caution when close to hot exhausts, moving parts, etc.

- Do not stand on a wet floor while working on electrical equipment. Use rubber insulative mats placed on dry wood platforms.

Fuel System

- DO NOT fill fuel tanks while engine is running, unless tanks are outside engine compartment. Fuel contact with hot engine or exhaust is a potential fire hazard.
- DO NOT SMOKE OR USE AN OPEN FLAME in the vicinity of the generator set or fuel tank. Internal combustion engine fuels are highly flammable.

REMEMBER—IF YOU CAN SMELL FUMES—A POSSIBLE EXPLOSION AND FIRE CONDITION EXISTS!

- Make sure that oily rags are not left on or near the engine. Oil soaked rags are combustible and present hazardous walking conditions.
- Fuel lines must be of steel piping, adequately secured, and free from leaks. Piping at the engine should be approved flexible line. Do not use copper piping on flexible lines as copper will work harden and become brittle.
- Your engine installation should be equipped with a means of positive fuel shutoff in applications when fuel is conducted from a remote source. Fuels under pressure (e.g. natural gas or liquefied petroleum gas) should be controlled by a positive shutoff valve, preferably automatic, in addition to any valve integral with the carburetor or gas regulator equipment.

Exhaust System

- Exhaust products of any internal combustion engine are toxic and can cause serious personal injury, if inhaled. All engine installations, especially those within a confine, should be equipped with an exhaust system to discharge gases to the atmosphere. Do not use exhaust gases to heat a compartment.
- Inspect exhaust system regularly to assure that system is free of leaks.

Coolant System

- Coolants under pressure have a higher boiling point than that of water. DO NOT open a radiator or heat exchanger pressure cap or break a system while the engine is running, and in no case until the system pressure has been bled off.
- Radiator fan belts are guarded for your protection. DO NOT remove covers or guards.
- Keep your hands away from moving parts.

Ventilation System

- Check remote radiators frequently. Remove any dirt, debris, bird nests, etc.
- Check ventilation louvres frequently. Make sure that free-fall louvres and motor operated louvres open and close properly and that there is no restriction in the free-air flow.

Electrical System

- The electrical installation exterior to your generator should have been performed by qualified licensed electricians. All local and state

codes should have been consulted and complied with. It is essential that all load circuit breakers adequately protect electrical functions, all circuits are properly grounded and wiring is correct capacity.

- Tag open switches.
- DON'T tamper with interlocks.
- Before starting work on the generating set, disconnect batteries. This will prevent inadvertent starting of the set.
- Use extreme caution when making adjustments on the electrical components in the control cabinet while the engine is running. High voltages are present and could cause serious personal injury.
- DO NOT SMOKE while servicing batteries. Verify correct polarity of battery cables before connecting. Lead acid batteries give off a highly explosive hydrogen gas which can be ignited by electrical arcing or by smoking. When connecting batteries, connect the ground lead last.

SPECIFICATIONS

30 kW EK

ENGINE DETAILS

Engine Manufacturer	Ford
Engine Series	C5PG
Number of Cylinders.....	6
Displacement.....	300-in ³ (4.9 litre)
BHP @ 1800 r/min.....	80 (59.68 kW)
Compression Ratio	8.4:1
Bore	4.00-inch (101.6 mm)
Stroke	3.98-inch (101.09 mm)
Fuel	Gas/Gaso
Battery Voltage.....	12
Battery Group—One 12-Volt, 74 A.H. (266 kC)	Type 60
Starting Method	Solenoid Shift
Governor Regulation.....	5% Max. No Load—Full Load
Battery Charging Current	35-Amperes

GENERATOR DETAILS

Type.....	UR15 60 Hz	UR515 50 Hz
Rating (Watts)		
60 Hertz Continuous Standby	30 000 (37.5 kVA)	
50 Hertz Continuous Standby	25 000 (31.25 kVA)	
AC Voltage Regulation.....	±2%	
60 Hertz r/min.....	1800	
50 Hertz r/min.....	1500	
Output Rating	0.8 PF	
AC Frequency Regulation.....	3 Hz Max	

CAPACITIES AND REQUIREMENTS

Cooling System, Engine and Radiator	20-quarts (19 litres)
Engine Oil Capacity (Filter, Lines, Crankcase).....	7-quarts (6.6 litres)
Exhaust Connection (inches pipe thread)	2

AIR REQUIREMENTS (1800 r/min)

Engine Combustion.....	100 ft ³ /min (0.05 m ³ /s)
Radiator Cooled Engine.....	5 335 ft ³ /min (2.52 m ³ /s)
Total for Radiator Cooled Model	5 435 ft ³ /min (2.6 m ³ /s)
Alternator Cooling Air (1800 r/min).....	1 000 ft ³ /min (0.5 m ³ /s)
(1500 r/min).....	833 ft ³ /min (0.4 m ³ /s)
Fuel Consumption at Rated Load	
Gasoline (Regular)	4.9 gal/hr (5.15 cm ³ /s)
Natural Gas (1000 BTU/ft ³ [37.25 MJ/m ³]).....	600-ft ³ /hr (0.28 m ³ /min)
LPG (2500 BTU/ft ³ [93.1 MJ/m ³]).....	245-ft ³ /hr (0.12 m ³ /min)

GENERAL

Height	45.56-inches (1.16 m)
Width	33.00-inches (0.84 m)
Length	71.81-inches (1.82 m)
Approximate Weight (Mass)	1395-lb (633 kg)
	1550-lb (703 kg)

SPECIFICATIONS

45 kW EM

ENGINE DETAILS

Engine Manufacturer	Ford
Engine Series	C5PG
Number of Cylinders	6
Displacement	300-in ³ (4.9 litre)
BHP @ 1800 r/min	98 (73 kW)
Compression Ratio	8.4:1
Bore	4.00-inch (101.6 mm)
Stroke	3.98-inch (101.09 mm)
Fuel	Gas/Gaso
Battery Voltage	12
Battery Group—One 12-Volt, 74 A.H. (266 kC)	Type 60
Starting Method	Solenoid Shift
Governor Regulation	5% Max. No Load—Full Load
Battery Charging Current	35-Amperes

GENERATOR DETAILS

Type	UR15 60 Hz	UR515 50 Hz
Rating (Watts)		
60 Hertz Continuous Standby	45 000 (56.25 kVA)	
50 Hertz Continuous Standby	37 500 (46.87 kVA)	
AC Voltage Regulation	±2%	
60 Hertz r/min	1800	
50 Hertz r/min	1500	
Output Rating	0.8 PF	
AC Frequency Regulation	3 Hz Max	

CAPACITIES AND REQUIREMENTS

Cooling System, Engine and Radiator	20-quarts (19 litres)
Engine Oil Capacity (Filter, Lines, Crankcase)	7-quarts (6.6 litres)
Exhaust Connection (inches pipe thread)	2

AIR REQUIREMENTS (1800 r/min)

Engine Combustion	125-ft ³ /min (0.059 m ³ /s)
Radiator Cooled Engine	5 335-ft ³ /min (2.52 m ³ /s)
Total for Radiator Cooled Model	5 460-ft ³ /min (2.6 m ³ /s)
Alternator Cooling Air (1800 r/min)	1000-ft ³ /min (0.5 m ³ /s)
(1500 r/min)	833-ft ³ /min (0.4 m ³ /s)
Fuel Consumption at Rated Load	
Gasoline (Regular)	7.3-gal/hr (7.68 cm ³ /s)
Natural Gas (1000 BTU/ft ³ [37.25 MJ/m ³])	690 ft ³ /hr (0.32 m ³ /min)
LPG (2500 BTU/ft ³ [93.1 MJ/m ³])	290 ft ³ /hr (0.14 m ³ /min)

GENERAL

Height	45.56 inches (1.16 m)
Width	33.00 inches (0.84 m)
Length	73.19 inches (1.86 m)
Approximate Weight (Mass)	3-phase 1455 lb (660 kg)
	1-phase 1610 lb (730 kg)

TABLE 1
SERIES EK " " " GENERATOR VOLTAGE/CURRENT OPTIONS

VOLTS	FREQ	PHASE	AMPERES	DOUBLE DELTA	SERIES DELTA	PARALLEL WYE	SERIES WYE	REF VOLTAGE WIRE (W12) TAP
110/220	50 Hz	1	142*	x				H6
115/230	50 Hz	1	136*	x				H6
120/240	60 Hz	1	156*	x				H5
110/190	50 Hz	3	95			x		H3
115/200	50 Hz	3	90			x		H4
120/208	50 Hz	3	87			x		H4
120/208	60 Hz	3	104			x		H3
110/220	50 Hz	3	82		x			H6
127/220	50 Hz	3	82			x		H5
127/220	60 Hz	3	98			x		H4
115/230	50 Hz	3	78		x			H6
120/240	60 Hz	3	90		x			H5
139/240	60 Hz	3	90			x		H5
220/380	50 Hz	3	47				x	H3
230/400	50 Hz	3	45				x	H4
240/416	50 Hz	3	43				x	H4
240/416	60 Hz	3	52				x	H3
254/440	50 Hz	3	41				x	H5
254/440	60 Hz	3	49				x	H4
277/480	60 Hz	3	45				x	H5
9X 347/600	60 Hz	3	36					H5—Not Reconnectible
3 120/240	60 Hz	1	156					H5—Not Reconnectible

30 kW 37.5 kVA 60 Hz
25 kW 31.25 kVA 50 Hz

* - These current values are available only from special long stack units (B125 option). When standard 3 phase unit is connected into Double Delta configuration, maximum current is 2/3 that of value given.

SERIES EM

**TABLE 1A
GENERATOR VOLTAGE/CURRENT OPTIONS**

VOLTS	FREQ	PHASE	AMPERES	DOUBLE DELTA	SERIES DELTA	PARALLEL WYE	SERIES WYE	REF VOLTAGE WIRE (W12) TAP
110/220	50 Hz	1	213*	x				H6
115/230	50 Hz	1	204*	x				H6
120/240	60 Hz	1	234*	x				H5
110/190	50 Hz	3	142			x		H3
115/200	50 Hz	3	135			x		H4
120/208	50 Hz	3	130			x		H4
120/208	60 Hz	3	156			x		H3
110/220	50 Hz	3	123		x			H6
127/220	50 Hz	3	123			x		H5
127/220	60 Hz	3	148			x		H4
115/230	50 Hz	3	118		x			H6
120/240	60 Hz	3	135		x			H5
139/240	60 Hz	3	135			x		H5
220/380	50 Hz	3	71				x	H3
230/400	50 Hz	3	68				x	H4
240/416	50 Hz	3	65				x	H4
240/416	60 Hz	3	78				x	H3
254/440	50 Hz	3	62				x	H5
254/440	60 Hz	3	74				x	H4
277/480	60 Hz	3	68				x	H5
9X 347/600	60 Hz	3	54					H5—Not Reconnectible
3 120/240	60 Hz	1	234					H5—Not Reconnectible

45 kW 56.25 kVA 60 Hz
37.5 kW 46.87 kVA 50 Hz

* - These current values are available only from special long stack units (B125 option). When standard 3 phase unit is connected into Double Delta configuration, maximum current is 2/3 that of value given.

120/240 VOLT, 1 PHASE, 60 HERTZ

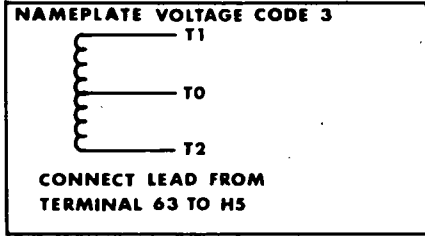

347/600 VOLT, 3 PHASE, 60 HERTZ

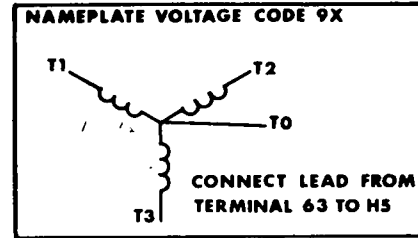

+

THIS DIAGRAM APPLIES TO 12 LEAD GENERATORS ONLY

*ADD
REVISED*

NAMEPLATE VOLTAGE CODE	VOLTAGE	PHASES	HERTZ	CONNECT LEAD FROM TERMINAL 63 TO:	GENERATOR CONNECTION	GENERATOR CONNECTION SCHEMATIC DIAGRAM	GENERATOR CONNECTION WIRING DIAGRAM (WITH CURRENT TRANSFORMERS WHEN USED)			
15	120/240	1	60	H5	DOUBLE DELTA					
515	115/230 110/220	1	50	H6 H6						
15	120/240	3	60	H5	SERIES DELTA					
515	115/230 110/220	3	50	H6 H6						
15	120/208 127/220	3	60	H3 H4 H5	PARALLEL WYE					
515	110/190 115/200 120/208 127/220	3	50	H3 H4 H4 H5						
15	240/416 254/440 277/480	3	60	H3 H4 H5				SERIES WYE		
515	220/380 230/400 240/416 254/440	3	50	H3 H4 H4 H5						

98C2193

+

FIGURE 1. OPTIONAL VOLTAGE CONNECTIONS

DESCRIPTION

GENERAL

An Onan EK or EM series electric generating set is a complete unit consisting of an engine driven AC generator, with standard and optional controls and accessories as ordered.

ENGINE

The engine on these units is a Ford C5PG as described in the engine manual. Basic measurements and requirements will be found under *SPECIFICATIONS*. For operation, maintenance and service information, consult the Ford manual.

AC GENERATOR

The generator is an ONAN Type UR, 12 lead, 4-pole revolving field, reconnectable, brushless unit. The main rotor is attached directly to the engine flywheel, therefore engine speed determines generator output frequency. The 60 Hz set operates at 1800 r/min, the 50 Hz at 1500 r/min. Excitation is achieved as follows—

Residual alternating current from the stator winding is applied to the voltage regulator, where it is compared with a reference voltage, rectified and returned to the field winding of the exciter. Current then induced in the exciter rotor is rectified and fed into the generator rotor. This induces a current in generator stator which is applied to the load.

CONTROL PANEL

The following is a brief description of each of the standard controls and instruments located on the face of the panel. See Figure 2.

DC Panel

Panel Light and Switch: Illuminates control panel.

Oil Pressure Gauge: Indicates pressure of lubricating oil in engine (wired to a sensor unit located on the engine).

Water Temperature Gauge: Indicates temperature of circulating coolant in engine. (Wired to a sensor unit located on the engine.)

Battery Charge Rate DC Ammeter: Indicates battery charging current.

Run/Stop/Reset-Remote Switch: Starts and stops the unit locally or transfers control to a remote location. Resets engine monitor relay in Stop/Reset position.

Warning Light: Indicates "Fault" in engine operation.

AC Panel

AC Voltmeter: Indicates AC generator output voltage. Dual range instrument: measurement range in use shown on indicator light.

Voltage Regulator: Rheostat, provides approximately plus or minus 5% adjustment of the rated output voltage.

Exciter Circuit Breaker: Provides generator exciter and regulator protection from overheating, in the event of certain failure modes of the generator, exciter and voltage regulator.

Running Time Meter: Registers the total number of hours, to 1/10th, that the unit has run. Use it to keep a record for periodic servicing. Time is accumulative, meter cannot be reset.

Voltmeter Phase Selector Switch: Selects phases of generator output to be measured by the AC voltmeter.

OPTIONAL EQUIPMENT

DC Panel

Warning Lights: Eliminates the one "Fault" light and substitutes five indicator (see Figure 3) lights to give warning of—

- Overcrank
- Overspeed
- Low oil pressure
- High engine temperature
- Low engine temperature

Operation of these lights will be discussed in conjunction with engine monitor panel.

Reset Switch: Manual reset for engine monitor after shut-down.

Lamp Test: Press to test warning lamp bulbs (when engine is running only), on five light panels.

AC Panel

AC Ammeter: Indicates AC generator output current. Dual range in use shown on indicator lights.

Frequency Meter: Indicates the frequency of the generator output in hertz. It can be used to check engine speed. (Each hertz equals 30 r/min.)

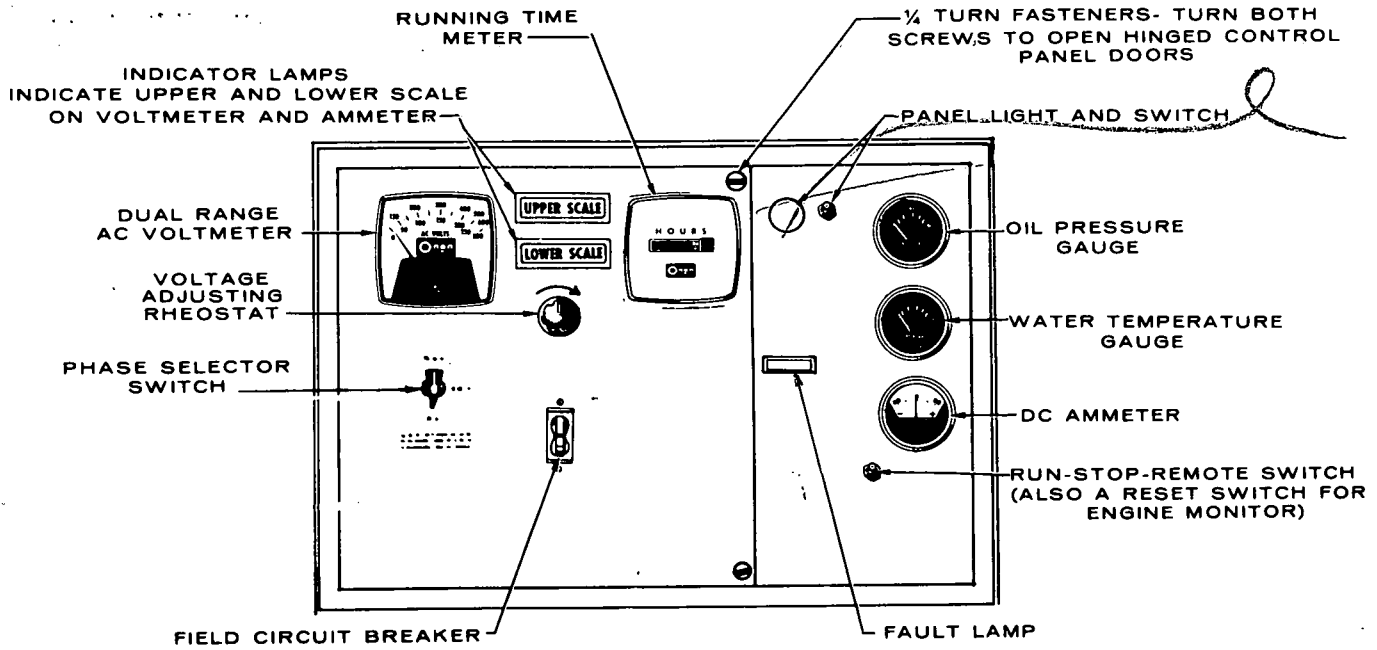

FIGURE 2. TYPICAL CONTROL PANEL (ONE FAULT LAMP)

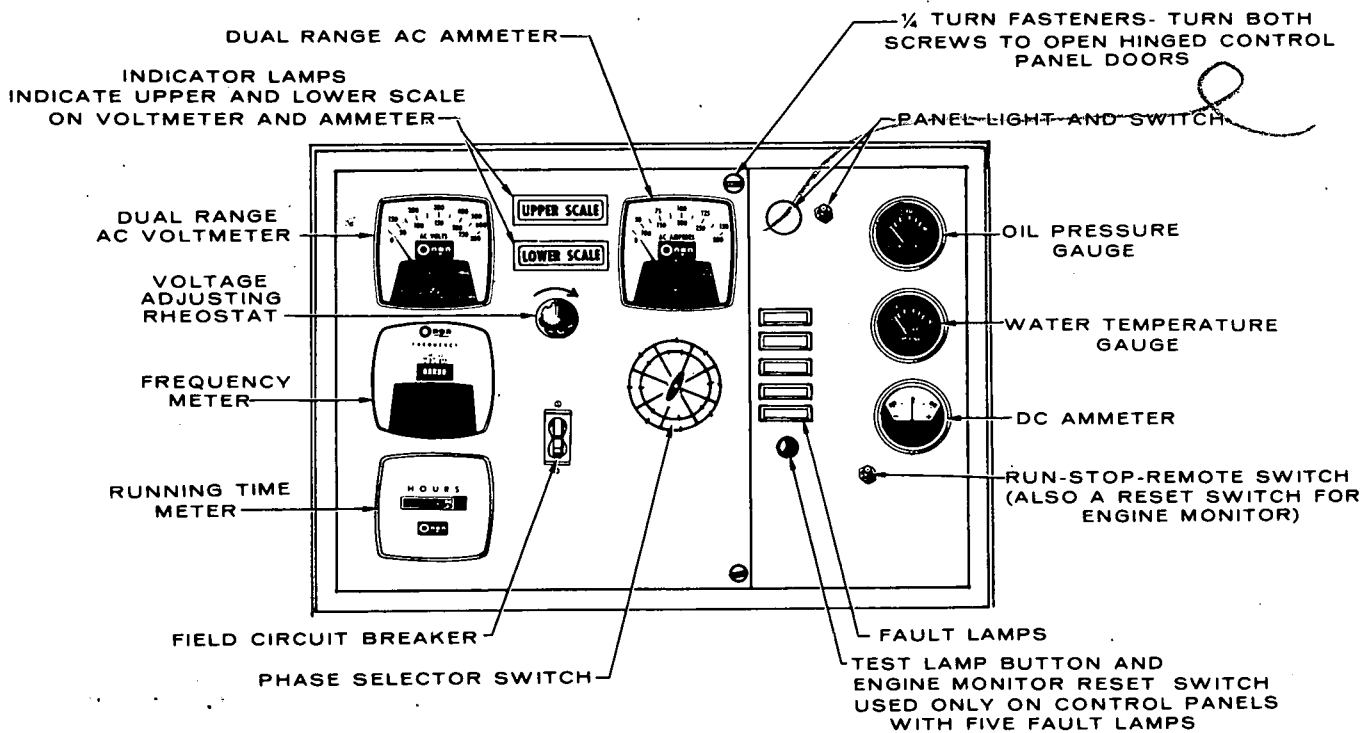

FIGURE 3. OPTIONAL CONTROL PANEL (FIVE FAULT LAMPS)

CONTROL PANEL INTERIOR

The only equipments discussed in this section will be those which the operator may have reason to adjust or inspect for service.

Terminal Board (TB) 21: Connection of wire W12 to terminals H3, H4, H5, and H6 is made at this point, to change reference voltage when reconnecting generator for different voltages. Refer to Figure 1.

Voltage Regulator, Begin Spec F: Solid state unit, consisting of printed circuit board VR21; an SCR bridge CR21, with a commutating reactor L21 are located in the control panel as part of the voltage regulator system. AC output from generator is controlled at predetermined level regardless of load; regulation is plus or minus 2% from no load to full load, at 0.8 P.F.

Voltage Regulator, Prior to Spec F: Solid state unit consisting of printed circuit board VR21.

An exciter-regulator assembly designated VR22 containing an SCR bridge circuit and commutating reactor is mounted on the generator end bell (see Figure 4) and works in conjunction with VR21.

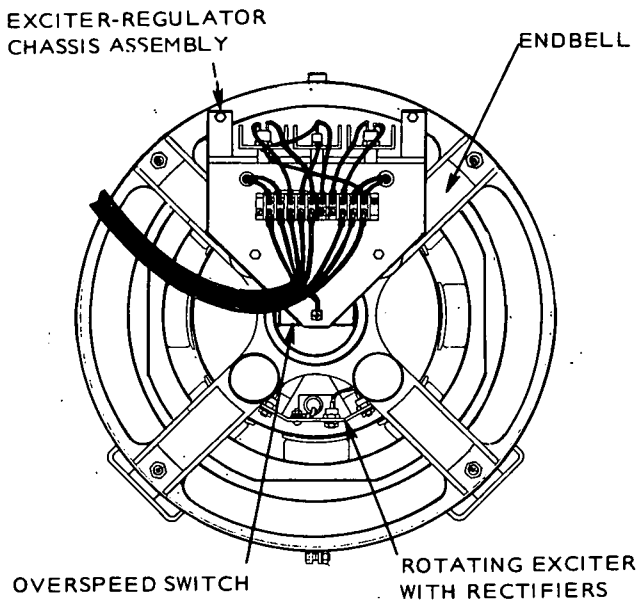

FIGURE 4. REGULATOR ASSEMBLY
(Prior to Spec F)

Engine Monitor: Printed circuit plug-in modules provide the following functions:

1. A 75 second cranking period.
2. Approximately a 12.5-second time delay for oil pressure buildup.
3. An external alarm contact to light a fault lamp and shut down the set for alarm conditions such as:
 - a. Overcrank (failed to start after cranking 75 seconds).
 - b. Overspeed (engine speed reaches 2100 r/min).
 - c. Low oil pressure 14 psi (96.5 kPa).
 - d. High engine temperature 215° F (102° C) ²⁰⁵⁰

CAUTION High Engine Temperature Cutoff will shut down engine in an overheat condition only if coolant level is sufficiently high to physically contact shutdown switch. Loss of coolant will allow engine to overheat without protection of shutdown device, thereby causing severe damage to the engine. It is therefore imperative that adequate engine coolant levels be maintained, to ensure operational integrity of cooling system and engine coolant overheat shutdown protection.

On standard control panels, all four alarms are wired into one common fault lamp; on units with five fault lamps, four have shutdown alarms, the fifth (low engine temperature) lights a fault lamp only. Refer to Table 2.

Standard Cranking Module: Limits engine cranking time to 75 seconds. If engine fails to start after 75 seconds the engine monitor lights a fault lamp and opens the cranking circuit.

OPTIONAL MODULES

Cycle Cranker: Plug-in module replaces standard cranking circuit. Automatically provides a 15-second crank time and a 10-second rest time for three ON and two OFF cycles in 65 seconds. If engine fails to start, after 75 seconds the engine monitor lights a fault lamp and opens the cranking circuit. The ON and OFF cycle times are nominal and can be adjusted at potentiometers on the cranker module board.

Pre-Alarm: Gives advance warning for low oil pressure or high engine temperature. Requires two sensors each for engine temperature and oil pressure.

TABLE 2. FAULT LAMP OPTIONS

SYSTEM	FAULT	FAULT LAMP	STOP ENGINE	EXTERNAL ALARM	PRE-ALARM
PENN STATE SINGLE LIGHT	Overcrank	x	x	x	
	Overspeed	x	x	x	
	Low Oil Pressure	x		x	
	High Engine Temperature	x		x	
STANDARD SINGLE LIGHT	Overcrank	x	x	x	
	Overspeed	x	x	x	
	Low Oil Pressure	x	x	x	
	High Engine Temperature	x	x	x	
5 LIGHT	Overcrank	x	x	x	
	Overspeed	x	x	x	
	Low Oil Pressure	x	x	x	
	High Engine Temperature	x	x	x	
	Low Engine Temperature	x			
5 LIGHT PRE-ALARM	Overcrank	x	x	x	
	Overspeed	x	x	x	
	Low Oil Pressure	x	*	x	x
	High Engine Temperature	x	*	x	x
	Low Engine Temperature	x			

* - With additional optional sensors.

ENGINE SENSORS

Resistance units and switches in the engine temperature and oil pressure monitoring and shut-down systems are sealed units and are not repairable.

For location, refer to Figures 5 and 6. When replacing a sensor, do not substitute, use recommended items. Resistance units are matched to the gauge they supply, and cut-off switches are close-tolerance actuation parts, made for a specific application.

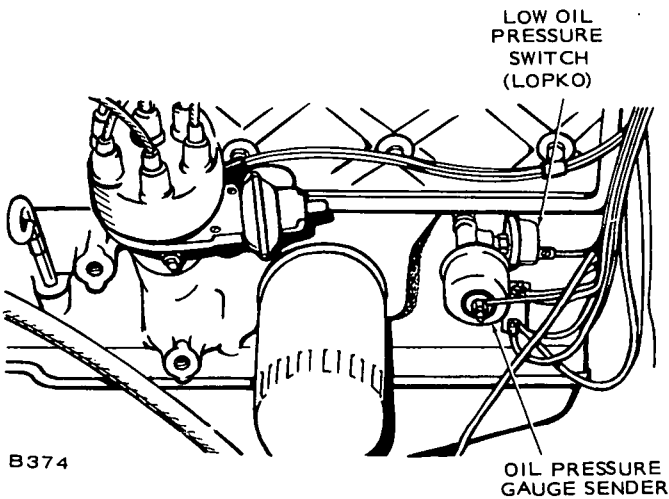
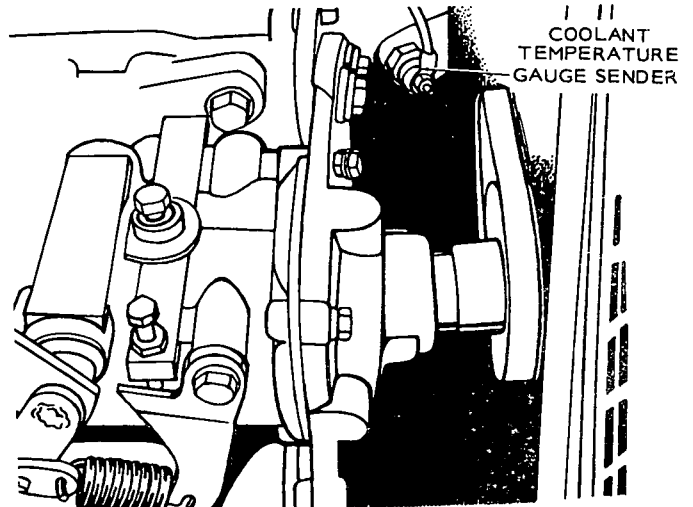
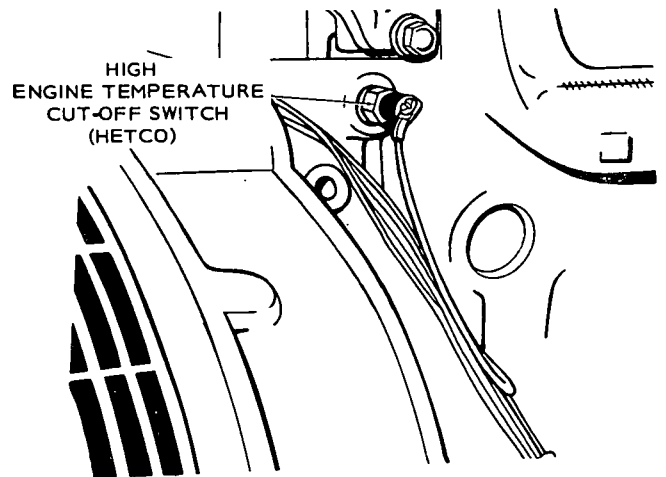

FIGURE 5. OIL PRESSURE MONITORS

FIGURE 6. ENGINE TEMPERATURE MONITORS

INSTALLATION

GENERAL

Installations must be considered individually. Use these instructions as a general guide. All installations must meet regulations of state and local building codes, fire ordinances, etc., which may affect installation details. See Figures 7 and 8. Refer to *ONAN Technical Bulletin T-030* for further installation information.

Requirements to be considered prior to installation:

1. Level mounting surface.
2. Adequate cooling air.
3. Adequate fresh induction air.
4. Discharge of circulated air.
5. Discharge of exhaust gases.
6. Electrical connections.
7. Fuel installation.
8. Water supply (city water cooling).
9. Accessibility for operation and servicing.
10. Vibration isolation.
11. Noise levels.

LOCATION

Provide a location that is protected from the weather and is dry, clean, dust free and well ventilated. If practical, install inside a heated building for protection from extreme weather conditions.

MOUNTING

Generator sets are mounted on a rigid skid base which provides proper support. The engine-generator assembly is isolated from the skid base by rubber mounts which provide adequate vibration isolation for normal installations. For installations where vibration control is critical, install additional spring-type isolators between skid base and foundation.

For convenience in general servicing and changing crankcase oil, mount set on raised pedestal at least 6-inches (150 mm) high.

VENTILATION

Generator sets create considerable heat which must be removed by proper ventilation. Outdoor installations rely on natural air circulation but indoor installations need properly sized and positioned vents for the required air flow. See *SPECIFICATIONS* for the air required to operate with rated load under normal conditions at 1800 r/min.

Radiator set cooling air travels from the rear of the set and is removed by a pusher fan which blows out through the radiator. Locate the air inlet to the rear of the set.

Locate the cooling air outlet directly in front of the radiator and as close as possible. The opening free area must be at least as large as the radiator area. Length and shape of the air outlet duct should offer minimum restriction to air flow. Use a duct of canvas or sheet metal between the radiator and the air outlet opening. The duct prevents recirculation of heated air.

For operation outside a building, a shelter housing with electrically operated louvres is available as an option. Transformers connected across the generator output supply current to the motors.

When the generator is operating, current in the transformers actuate the motors and open the louvres. The louvres are held open for the duration of the set operation, then are closed by return springs when the set is shut down.

City water cooled sets do not use the conventional radiator. A constantly changing water flow cools the engine. Sufficient air movement and fresh air must be available to properly cool the generator, disperse heat convected off the engine and support combustion in the engine.

Installations require an auxiliary fan (connected to operate only when the unit is running) of sufficient size to assure proper air circulation and evacuation of fumes.

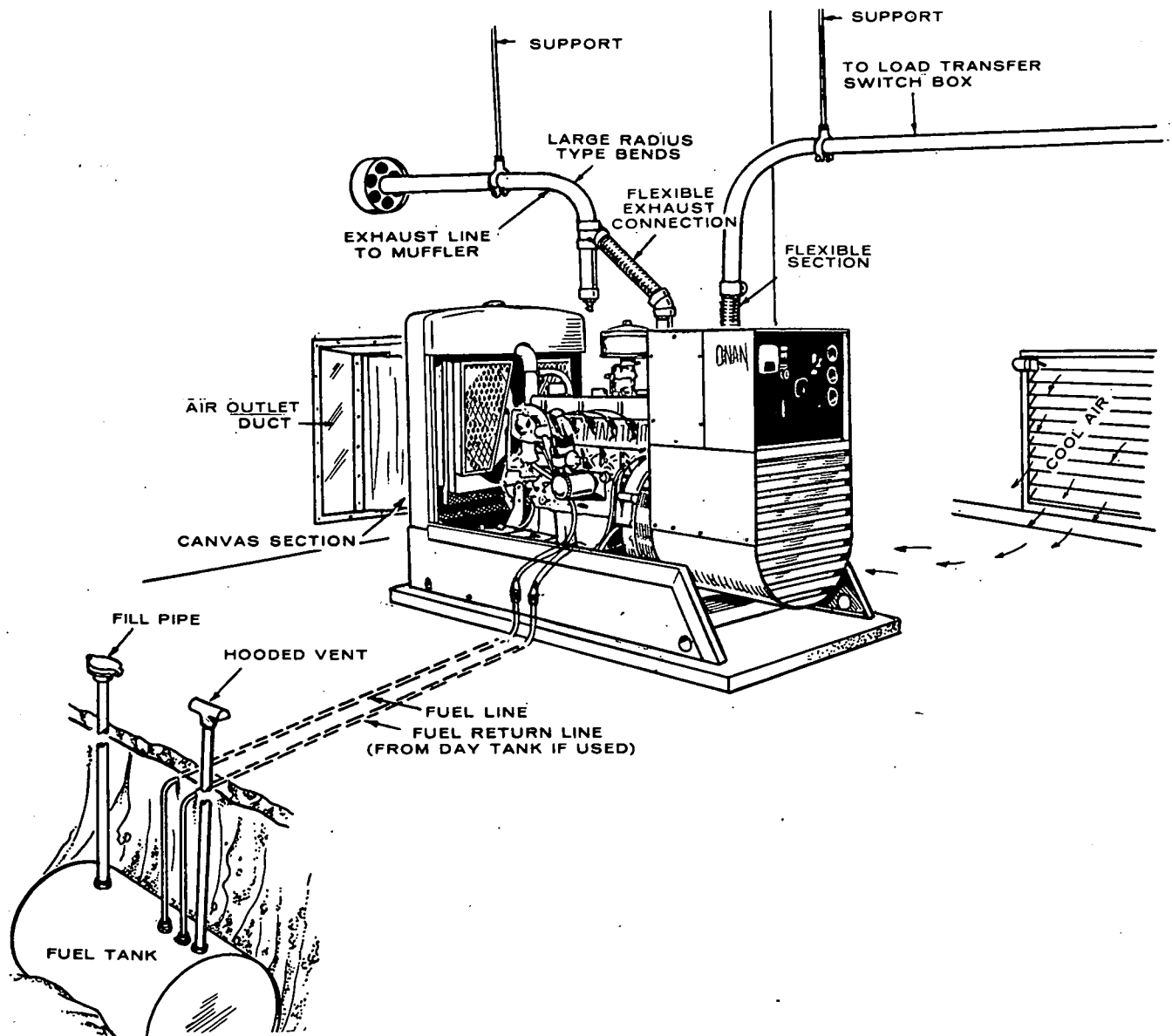

FIGURE 7. TYPICAL INSTALLATION

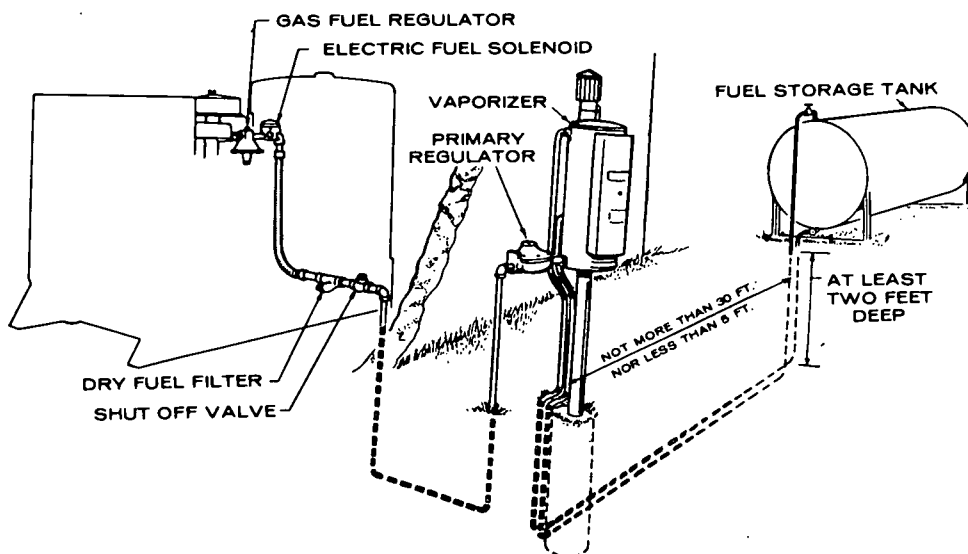

FIGURE 8. TYPICAL INSTALLATION OF LPG WITHDRAWAL SYSTEM

COOLING SYSTEM

Standard Radiator Cooling, uses a set mounted radiator and engine driven pusher type fan to cool engine water jacket. Air travels from the generator end of the set, across the engine and out through the radiator. An integral discharge duct adapter flange surrounds the radiator grille.

Heat Exchanger Cooling (optional), uses a shell and tube type heat exchanger instead of the standard radiator and fan. Engine jacket coolant circulates through the shell side of the heat exchanger, while raw cooling water is pumped through the tubes. Engine coolant and raw water do not mix. This type of cooling separation is necessary when the raw water contains scale forming lime, or other impurities.

This system reduces set enclosure airflow requirements and noise levels. Proper operation depends upon a constant supply of raw water for heat removal. The engine coolant side of the system may be protected from freezing; the raw water side cannot. See Figure 9 for typical installation.

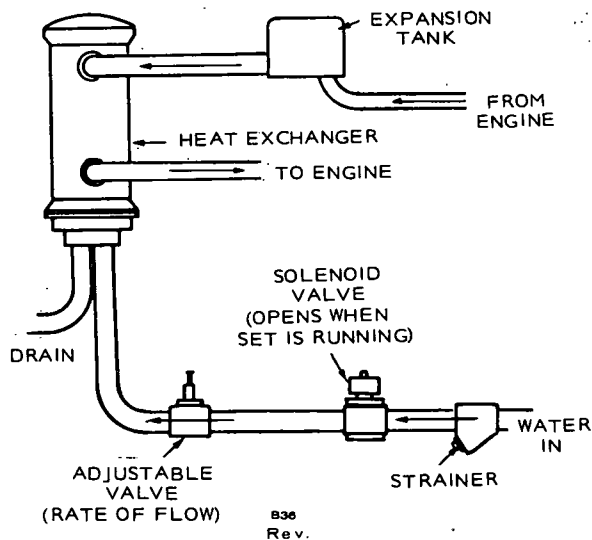

FIGURE 9. TYPICAL HEAT EXCHANGER SYSTEM

Standpipe Cooling (optional) substitutes a mixing (tempering) tank for the standard radiator and fan. Cooling water circulating through the engine jacket is mixed with raw water in the tank. Because raw water flows through the engine jacket, it must not contain scale forming impurities or fouling of the engine water passages will occur. Fouling results in engine overheating and costly repair bills.

This system reduces set enclosure airflow requirements and noise levels. Proper operation is dependent on a constant supply of cooling water. The system cannot be protected from freezing. See Figure 10.

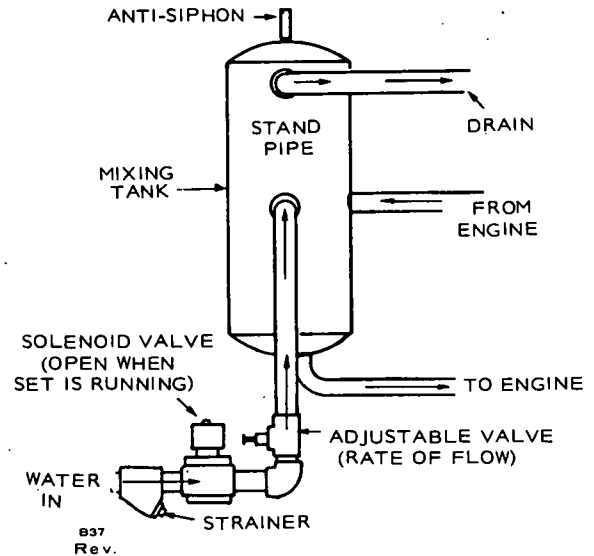

FIGURE 10. TYPICAL STANDPIPE SYSTEM

Remote Radiator Cooling (optional), substitutes a remote mounted radiator and an electrically driven fan, for the set mounted components. Removal of the radiator and fan from the set reduces set enclosure airflow requirements and noise levels without forcing dependence on a continuous cooling water supply. The remote radiator system can be completely protected against freezing.

This system must be designed to meet specific requirements of the application.

Water Jacket Heater (optional) may be installed to keep engine coolant warm while engine is shut down. It heats and circulates the coolant within the engine, which reduces start-up time and engine wear caused by cold starts. It is electrically operated and thermostatically controlled.

Direct Flow Installation

With this system, a city or raw water cooling supply under pressure forces water directly into the engine, through the engine and to the outlet. An adjustable valve controls the incoming water flow rate to obtain correct engine water temperature, as measured at engine coolant water outlet while the generator set is operating under full load. A solenoid valve is coordinated with the generator set system to open during set operation.



Restrict inlet water pressure to a maximum of 7 psi or 48.3 kPa, otherwise engine gaskets and seals will leak.

Raw water cooling is often undesirable because:

1. The water supply must be very clean or engine deposits will result.
2. A high temperature differential between the cold incoming water into the engine and warm discharged water can put damaging stresses on engine components (no overall uniform engine temperature).

COOLING CONNECTIONS

The radiator cooled (standard) set does not require any external connections except as discussed under *Ventilation*. Allow clearance around the set for access to service the radiator and fan belts. See Figure 7.

Heat Exchanger and Standpipe cooled sets must be connected to a pressurized supply of cold water. Make connections to the set with flexible pipe to absorb vibration. On the cool water line install a solenoid valve to shut off the flow when the set is shut down and a rate of flow valve to control engine temperature. This valve can be either manual or automatic. Actual rate of flow will depend on inlet water temperature and applied load.

Adjust the flow to maintain water temperature between 165° F and 195° F (73.9° C and 90.6° C) while viewing the water temperature gauge.

Before filling cooling system check all hardware for security. This includes hose clamps, capscrews, fittings and connections. Use flexible coolant lines with heat exchanger, standpipe or remote mounting radiator.

Remote radiator plumbing will vary with installation. All systems must comply with the following conditions—

1. Make all connections to the set and to the radiator with flexible pipe.
2. Install an auxiliary circulating pump if the horizontal distance between the engine and pump exceeds 15-feet (4.65 m).
3. Install a hot-well system to relieve excess engine water jacket pressure if the top of the radiator is more than 15-feet (4.65 m) above the center-line of the engine crankshaft.

EXHAUST

WARNING Inhalation of exhaust gases can result in death.

Engine exhaust gas must be piped outside building or enclosure. Do not terminate exhaust pipe near inlet vents or combustible materials. An approved thimble (Figure 11) must be used where exhaust pipes pass through walls or partitions. Pitch exhaust pipes downward or install a condensation trap (Figure 12) at the point where a rise in the exhaust system begins. Avoid sharp bends; use sweeping long radius elbows. Provide adequate support for mufflers and exhaust pipes. Refer to Figure 7 for a typical exhaust installation. Shield or insulate exhaust lines if there is danger of personal contact. Allow at least 9-inches (230 mm) of clearance if the pipes run close to a combustible wall or partition. Use a pipe at least as large as the 2-inch (50 mm) pipe size outlet of the engine.

Suspend the pipe from the enclosure structure and attach to engine with a flexible section. Place muffler as close to engine as possible to reduce condensation damage and carbon fouling.

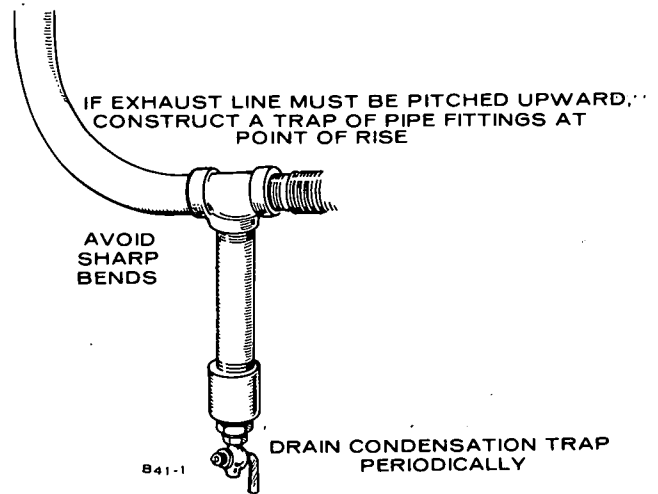

FIGURE 12. EXHAUST CONDENSATION TRAP

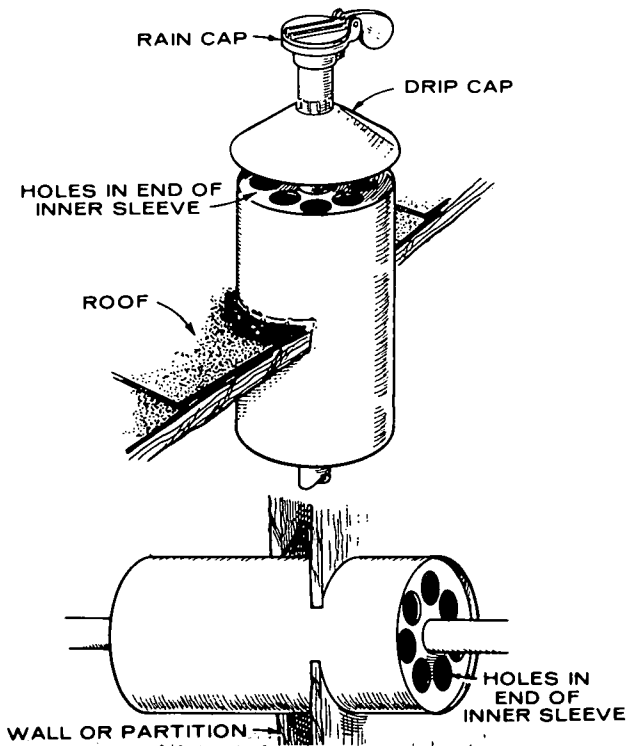

FIGURE 11. TYPICAL EXHAUST THIMBLE

Minimum diameters and maximum lengths of pipe (with critical muffler[s]) are as follows:

Single Exhaust system:

- 2.5-inch (67 mm) pipe 9-feet (3 m)
- 3.0-inch (76 mm) pipe 89-feet (27 m)
- 3.5-inch (90 mm) pipe 168-feet (51 m)

Maximum permissible exhaust restriction (back pressure) is 20.4-inches (508 mm) H₂O manometer, or 11.8 ounces (5.1 kPa) gauge.

FUEL SYSTEM

Ford engines used on EK/EM sets are designed to operate on gasoline (average regular grade of 93 octane), natural gas with thermal rating of 1000 BTU/ft³ (37.25 MJ/m³) or liquefied petroleum gas (LPG) Propane at 2500 BTU/ft³ (93.13 MJ/m³).

FUEL CONNECTIONS

Before starting any type of fuel installation, ONAN recommends that the regulations described in Pamphlet 58 of the National Fire Prevention Association (NFPA) be studied. All pertinent state and local codes, most of which are governed by NFPA 58, must be complied with, and the installation must be inspected before the unit is put in service.

Fuels under pressure (e.g. natural gas or LPG) must be controlled by a positive shut off valve, preferably automatic, in addition to any valve integral with the carburetor or gas regulator equipment.

Connection of gasoline fuel inlet line requires a 1/8-inch pipe fitting to an adapter on skid base.

Lift to fuel pump should not exceed 6 feet (2 m), horizontal distance between set and fuel tank should not exceed 50 feet (15 m). Use 3/8-inch tubing up to 25 feet (12.5 m), 1/2-inch up to 50 feet (15 m).

Optional Day Tank: The engine may be equipped with a one quart reservoir tank to replenish fuel lost from the carburetor by evaporation during shutdown. See Figure 13. Connect a 5/16-inch return line between the reservoir upper side fitting (this fitting has a restricted orifice and must be used) and the main supply tank. Be sure the return line has a continuous drop to the main supply tank with no dip-and-rise where fuel could collect and form a vent seal. See that the top center opening of the tank is tightly plugged.

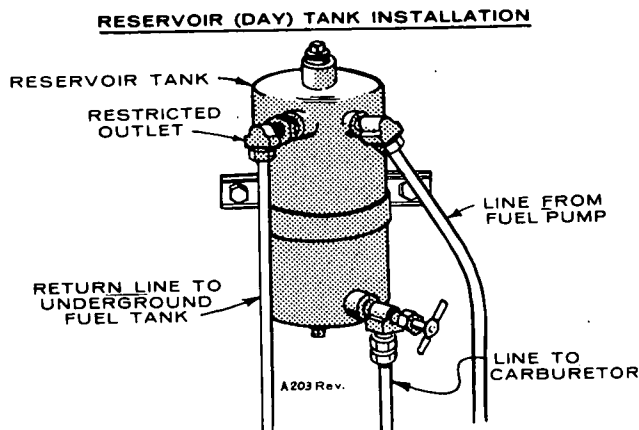

FIGURE 13. DAY TANK INSTALLATION

Natural or Manufactured Gas: On sets equipped with an Impco carburetor, gas pressure at the carburetor must be set at 3-ounces (1.3 kPa) gauge, or 5-inch (127 mm) water column, manometer, with the engine running at 1800 r/min on no load.

Thermac regulator is designed for a maximum line pressure of 6-ounces (2.6 kPa) gauge, or 10.38-inches (263.6 mm) water column, manometer.

If line pressure is excessive, install a suitable pressure reducing regulator. Be sure to comply with all local regulations such as:

- Recommended electric shutoff valve.
- Hand shutoff valve at the fuel source.
- Supply line filter.

Use a short length of approved flexible connection between the supply pipe and the set regulator inlet.

Combination Gas-Gasoline: Combination gas-gasoline sets are designed for normal operation on gas fuel, with provision for emergency operation on gasoline. Both gas and gaso procedures must be followed. A reservoir tank is sometimes provided, so a fuel return line may be necessary as described for gasoline fuel.

BATTERY

Starting the unit requires 12-volt battery current. Use one 12-volt (see specification) battery for a normal installation. Connect the battery as in Figure 14. Necessary battery cables are on unit. Service battery as necessary. Infrequent set use (as in emergency standby service) may allow battery to self-discharge to the point where it cannot start the unit. If installing an automatic transfer switch that has no built-in charge circuit, connect a separate trickle charger. Onan automatic transfer switches include such a battery charging circuit.

WARNING

Do not smoke while servicing batteries. Lead acid batteries give off explosive gases while being charged.

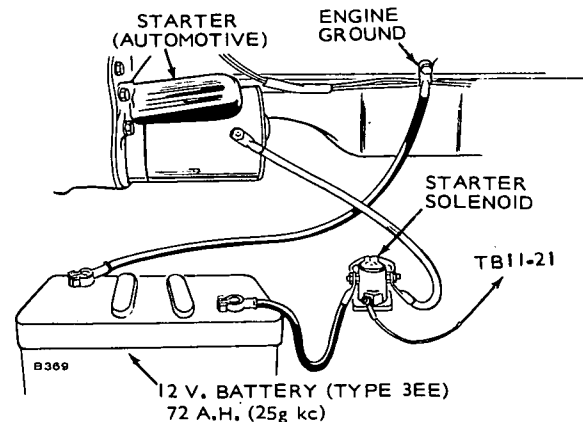

FIGURE 14. BATTERY CONNECTION

REMOTE CONTROL CONNECTIONS

Provision is made for addition of remote starting. This is accomplished on a 4 place terminal block situated within the control box. Connect one or more remote switches across remote terminal and B+ terminal as shown in Figure 15. If the distance between the set and remote station is less than 1000-feet (305 m), use No. 18 AWG wire; between 1000- and 2000-feet (305 m and 610 m), use No. 16 AWG wire.

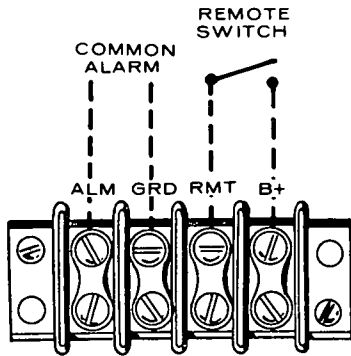

FIGURE 15. REMOTE START CONNECTION (TB12)

WIRING CONNECTIONS

Most local regulations require that wiring connections be made by a licensed electrician and that the installation be inspected and approved before operation. All connections, wire sizes, etc. must conform to requirements of electrical codes in effect at the installation site.

Generator set grounding must be in accordance with National Electrical Code (NFPA 70-1975) Article 250.

If the installation is for standby service, a double throw transfer switch must always be used. Connect this switch (either automatic or manual) so that it is impossible for commercial power and generator current to be connected to the load at the same time. See Figure 16. Instructions for connecting an automatic load transfer control are included with such equipment.

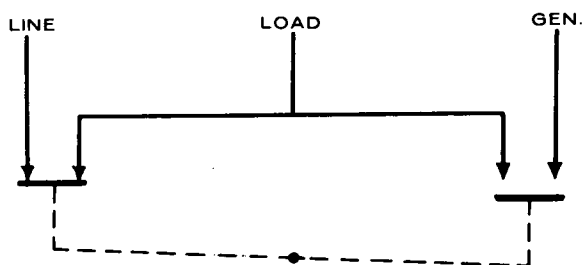

NOTE: SHOWN WITH LINE CONNECTED TO LOAD.

FIGURE 16. LOAD TRANSFER SWITCH (TYPICAL FUNCTION)

Control Box Connections: The factory ships these 12 lead generators with load connection wires NOT connected together in the control box. These 12 wires are labeled T1 through T12 and must be brought together before making load connections. Proceed as follows:

1. Remove either right, left or top panel from control box. See Figure 17.
2. Connect wires together as shown on panel drawing and in Figure 1 according to voltage desired.
3. Open hinged control panel doors. Connect lead from terminal 63 to correct terminal for voltage desired. These terminals are labeled H2, H3, H4, H5 and H6. See Figure 18.

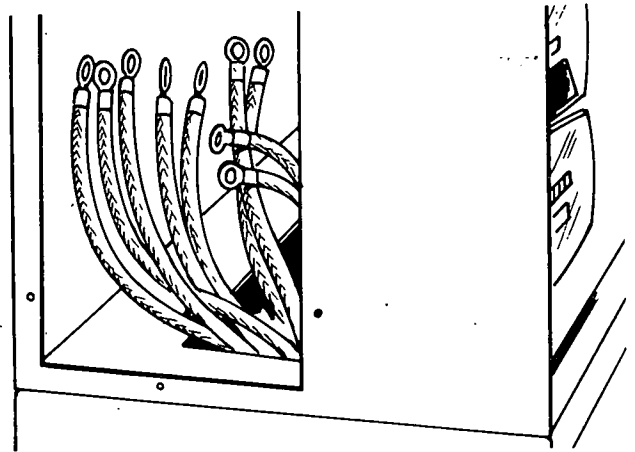

FIGURE 17. CONTROL BOX (SIDE PANEL REMOVED)

4. Close front panel and secure with 1/4 turn fasteners.
5. Connect load wires to generator leads.

Preceding instructions do not apply to models designated Code 3 or 9X; this connection is made at the factory. The installer must only connect load wires.

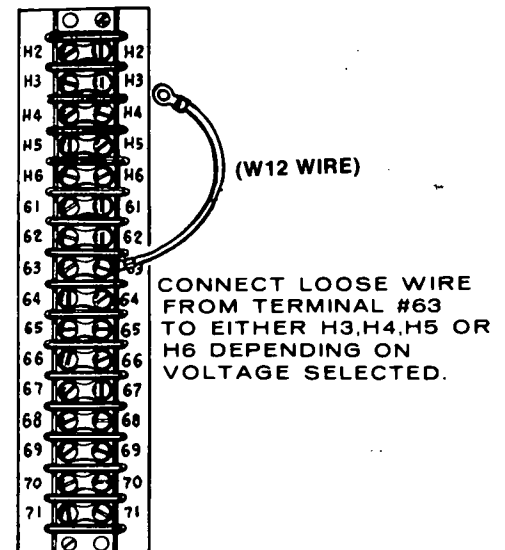

FIGURE 18. REFERENCE VOLTAGE CONNECTION (TB21)

120/240 Volt, Single Phase, 12 Lead: Terminal connection L0 can be grounded (neutral). For 120 volts, connect the hot load wires to either the L1 or L2 connection, Figure 19. Connect the neutral load wire to the grounded L0 connection. Two 120 volt circuits are thus available, with not more than 1/3 the rated capacity of the set available on either circuit. If using both circuits, be sure to balance the load between them.

For 240 volts, connect one load wire to the L1 connection and the second load wire to the L2 connection. Terminal connection L0 is not used for 240 volt service.

Only 2/3 of rated current is available from this connection.

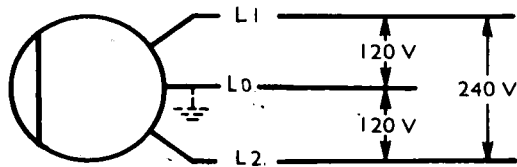

FIGURE 19. 120/240 V. 1-PHASE DOUBLE DELTA

120/240 Volt, 3 Phase, Delta Connected Set; 12 Lead:

The 3 phase Delta connected set is designed to supply 120 and 240 volt, 1 phase current and 240 volt, 3 phase current, Figure 20. For 3 phase operation, connect the three load wires to generator terminals L1, L2 and L3—one wire to each terminal. For 3 phase operation the L0 terminal is not used.

For 120/240 volt, 1 phase, 3 wire operation, terminals L1 and L2 are the "hot" terminals. The L0 terminal is the neutral, which can be grounded if required. For 120 volt service, connect the black load wire to either the L1 or L2 terminal. Connect the neutral (white) wire to the L0 terminal. Two 120 volt circuits are available. Connect between any two 3-phase terminals for 240 volt 1-phase loads.

Any combination of 1 phase and 3 phase loading can be used at the same time as long as total current does not exceed the NAMEPLATE rating of the generator. If no 3 phase output is used, usable 1 phase output is 2/3 of 3 phase kVA.

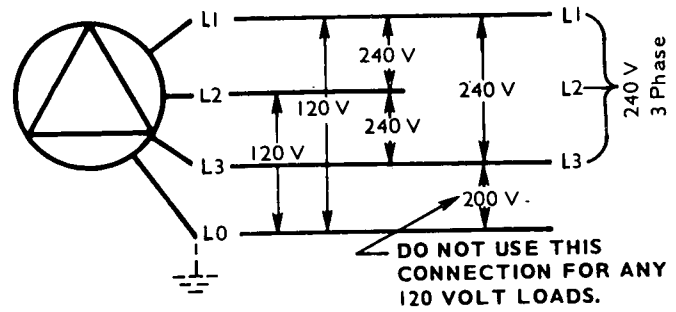

FIGURE 20. 120/240 V. 3-PHASE DELTA

3 Phase, Wye Connected Set: The 3 phase, 4 wire set produces line to neutral voltage and line to line voltage. Line to neutral voltage is the lower voltage as noted on the unit nameplate, line to line voltage is the higher nameplate voltage.

For 3 phase loads, connect separate load wires to each of the set terminals L1, L2 and L3. Single phase output of the higher nameplate voltage is obtained between any two 3 phase terminals as shown in Figure 21.

The terminal marked L0 can be grounded. For 1 phase loads, connect the neutral (white) load wire to the L0 terminal. Connect the black load wire to any one of the other three terminals—L1, L2 or L3. Three separate 1 phase circuits are available, with not more than 1/6 the rated capacity of the set from any one circuit.

If using 1 phase and 3 phase current at the same time, use care to properly balance the 1 phase load, and not to exceed rated line current.

Figure 21 shows load connections for 120/208 voltage. Other voltages are available from either parallel wye or series wye illustration in Figure 1.

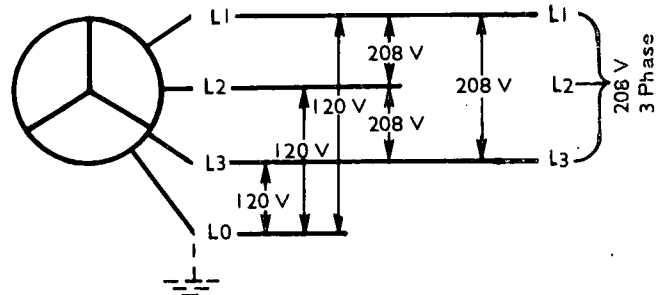

FIGURE 21. 120/208 V. 3-PHASE WYE

120/240 Volt, 1 Phase, 3 Wire Unit (3R Units):

Terminal post T0 is the grounded (neutral) terminal. For 120 volt current, connect the "hot" load wire to either the T1 or T2 terminal. Connect the neutral load wire to the T0 terminal. Two 120 volt circuits are thus available, with not more than 1/2 the rated capacity of the set available on each circuit. Balance the load as closely as possible (Figure 22).

For 240 volt current, connect one load wire to terminal T1 and the second load wire to terminal T2. Terminal T0 is not used for 240 volt service.

CAUTION If using both 120 and 240 volt current at the same time, use care not to overload either circuit.

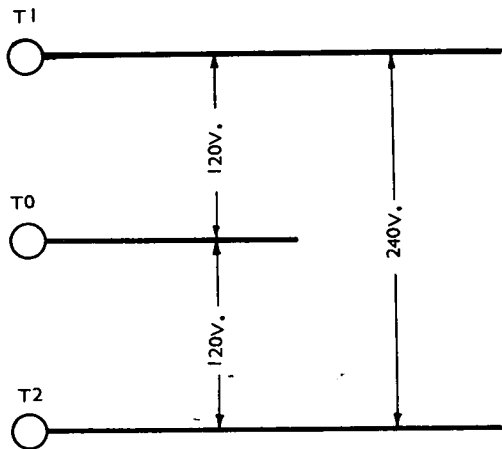

FIGURE 22. 120/240 V. 1-PHASE (CODE 3)

OPERATION

GENERAL

ONAN EK/EM Series electric generating sets are given a complete running test under various load conditions and are thoroughly checked before leaving the factory. Inspect your unit closely for loose or missing parts and damage which may have occurred in transit. Tighten loose parts, replace missing parts and repair any damage before putting set into operation.

PRESTART SERVICING

Lubrication System: Engine oil was drained prior to shipment. Fill engine to capacities shown. After engine has been run, check dipstick, add oil to bring level to safe mark (see Figure 23). Record total capacity for future oil changes. Do not mix brands nor grades of lubricating oils.



FIGURE 23. OIL LEVEL DIPSTICK

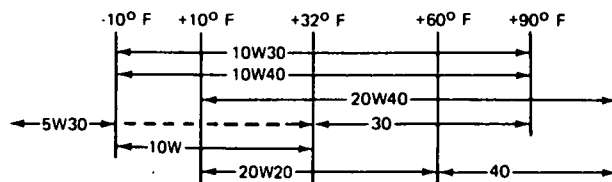

Oil capacities (nominal)

Oil Pan and Filter — 7-quarts (6.6 litres)

Cooling System: Cooling system was drained prior to shipment. Fill cooling system before starting. Nominal capacity is 20-quarts (19 litres). For units using either a radiator or heat exchanger (city water cooled), fill the system with clean soft water. Use a good rust and scale inhibitor additive. If a possibility exists of a radiator cooled set being exposed to freezing temperatures use anti-freeze with an ethylene-glycol base. During initial engine run, check the coolant level several times and replenish if necessary to compensate for air pockets which may have formed during filling. Refer to Ford engine manual for additional information.

CAUTION

1. Verify that the electric solenoid valve used with city water cooled sets is open before initial starting of set to allow coolant chambers to fill. Overheating and damage to the engine could result from non-compliance.

2. If engine is equipped with a cooling system filter, do not use antifreeze with an anti-leak formula. The stop leak element can prevent or retard the coolant flow through the filter, thereby eliminating the filtering process completely.

WARNING

Be careful when checking coolant under pressure. It is advisable to shut engine down and bleed off pressure before removing pressure cap. Severe burns could result from contact with hot coolant.

Fuel: If the set uses gasoline fuel, see that the fuel supply tank is properly filled with automotive "regular" gasoline. Do not use highly leaded premium grade gasoline. Check with the fuel supplier for assurance that the fuel supplied meets the specifications. Make every effort to keep the fuel supply clean.

If the set is equipped for gas fuel, see that the fuel supply is turned on. Observe all safety precautions regarding the use of gas fuel.

Combination Gas-Gasoline: A set designed for normal operation on gas fuel with provision for emergency operation on gasoline fuel, is equipped with a gas-gasoline toggle switch. Throw the switch to the appropriate position according to the type of fuel in use.

Check all connections in fuel system for security, to ensure that pressure will not bleed off when engine is not in use. Pressure should be maintained for immediate starting if unit is on standby service.

BATTERIES

Ensure that the cable connections to the batteries are secure. Coat connections with petroleum based or non-conductive grease to retard formation of corrosive deposits.

Check level of electrolyte to be at split ring mark. Measure specific gravity of electrolyte: SG 1.280 at 80° F (26.7° C). If distilled water has been added or specific gravity is less than 1.280, place batteries on charge until desired reading is reached. Do not over charge.

STARTING

When the preceding service functions have been performed, recheck to verify unit is ready to start.

1. Crankcase filled.
2. Cooling system filled.
3. Batteries charged and connected.
4. Fuel solenoid valve open.

To start, move the "run-stop/reset-remote" switch to the "run" position. The engine should start after a few seconds of cranking. Immediately after start, observe the oil pressure gauge. Normal oil pressure is between 30- and 55-psi (207- and 380 N•m). Check the following gauges:

1. DC Ammeter—10 to 30 amperes.
2. AC Voltmeter—AC generator output voltage.
3. Frequency Meter—AC generator output frequency.

After running 10 minutes under load the water temperature gauge should have stabilized at 180° to 195° F (82° to 90° C). On city water cooled units an adjustable valve is connected in the water supply line. Adjust the hand wheel valve to provide a water flow that will keep the water temperature gauge reading within the range of 165° F to 195° F (74° C to 90° C).

Break-In Note: Run set at 50 percent rated load for the first half-hour of initial operation after reaching operating temperature.

Non-Start: If after a few seconds of cranking engine fails to start, or starts and runs then stops and fault lamp lights, refer to appropriate troubleshooting chart, Table 3 or Table 4.

STOPPING

To reduce and stabilize engine temperatures, run the engine at no load for three to five minutes before shutting down.

Move the run-stop/reset-remote switch to stop position to shut down the set.

NO LOAD OPERATION

Periods of no load operation should be held to a minimum. If it is necessary to keep the engine running for long periods of time when no electric output is required, best engine performance will be obtained by connecting a "dummy" electrical load. Such a load could consist of heater elements, etc.

EXERCISE PERIOD

Generator sets on continuous standby service are required to be operative at essential loads from a cold start in a short period of time in the event of a power outage.

This imposes severe conditions on the engine. Friction of dry piston rings upon dry cylinder walls causes scuffing and rapid wearing. These can be relieved by exercising the set at least once a week for a minimum time of 30 minutes per exercise period. Preferably, run the set under at least 50 percent load to allow the engine to reach normal operating temperature. This will keep engine parts lubricated, maintain fuel prime, prevent electrical relay contacts from oxidizing and insure easy emergency starts. ONAN automatic transfer switches contain an optional exercise switch which, by pre-selection, will start, determine run period and shut down a set on a weekly frequency. For example, the switch can be set for time of start, length of run, A.M. or P.M. and day of week.

After each exercise period, top up fuel tank, check engine for leaks and unit for general condition. Locate cause of leaks (if any) and correct.

HIGH ALTITUDE

Ratings apply to altitudes up to 1000 feet (304 m) standard cooling, normal ambients and specified fuels. Consult factory or nearest authorized Onan distributor for operating characteristics under other conditions.

Engine horsepower loss is approximately 3 percent for each 1000 feet (304 m) of altitude above sea level for a naturally aspirated engine. Use lower power requirement at high altitudes to prevent smoke, over-fueling and high temperatures.

HIGH TEMPERATURES

1. See that nothing obstructs air flow to-and-from the set.
2. Keep cooling system clean.
3. Use correct SAE No. oil for temperature conditions.

LOW TEMPERATURES

1. Use correct SAE No. oil for temperature conditions. Change oil only when engine is warm.
2. Use fresh fuel. Protect against moisture condensation.
3. Keep fuel system clean and batteries in a well charged condition.
4. Partially restrict cool air flow but use care to avoid overheating.
5. Connect water jacket heater when set is not running.
6. Refer to Ford manual for further information.

**TABLE 3.
TROUBLESHOOTING ENGINE SHUTDOWN SYSTEM
(Engines with only one fault lamp)**

SYMPTOM	CORRECTIVE ACTION
1. Engine stops cranking and fault lamp lights, after cranking approximately 75 seconds.	1. See engine service manual for troubleshooting fuel system, ignition system, etc. After correcting problem, reset engine monitor relay by placing Run-Stop/Reset-Remote switch to Stop/Reset, then back to the required running position.
2. Fault lamp lights immediately after engine starts.	2. Check for: Overspeed condition as engine starts.
3. Fault lamp lights and engine shuts down after running for a period.	3. Check the following: a. Oil level. Engine will shut down if sensor is closed. b. Check engine manual for troubleshooting oil system. c. High engine temperature. Check coolant level; check water flow (city water cooled systems); check radiator for free air flow, and fan belts for tightness. See engine manual for troubleshooting cooling system. d. Check for faulty oil pressure sensor or faulty high engine temperature sensor.
4. Engine runs, shuts down and cranks for 75-seconds. Cranking cycle stops; fault lamp lights.	4. Check fuel supply. Check ignition system.
5. Fault lamp lights, no fault exists.	5. To check a no-fault condition, disconnect leads from TB11 terminals 29, 30 and 31. If fault lamp lights with leads disconnected, replace engine monitor board. Reconnect leads.

TABLE 4.
TROUBLESHOOTING ENGINE SHUTDOWN SYSTEM
(Units with five fault lamps)

SYMPTOM	CORRECTIVE ACTION
1. Overcrank fault lamp lights and engine stops cranking after approximately 75-seconds.	1. See engine service manual for troubleshooting fuel system, ignition system, etc. After correcting fault, reset engine monitor relay by placing Run-Stop/Reset-Remote switch to Stop/Reset position, depressing Reset button, then to the required running position.
2. Engine runs, shuts down, cranks for 75-seconds, cranking cycle stops, overcrank light ON.	2. Check fuel supply, check ignition.
3. *Low oil pressure shutdown.	3. Check — a. Oil level. Replenish if necessary. b. Sensor. Faulty sensor will shut down engine. c. Refer to engine service manual for troubleshooting guide for oil system.
4. *High engine temperature shutdown.	4. Check— a. Coolant level. Replenish if necessary. b. City water cooled sets. Check water flow, valves, etc. c. Check sensor; check thermostat. d. Radiator model, check fan belts, radiator for obstructions, etc.
5. Overspeed shutdown.	5. Check governor and throttle linkages for freedom of movement. Check overspeed switch.
6. Overspeed light on, no shutdown.	6. Disconnect wire at TB11-29. Light on after reset; replace engine monitor board.
7. *Low oil pressure light ON. No shutdown.	7. Disconnect wire at TB11-30. Light ON after relay reset. Replace engine monitor board.
8. *High engine temperature light ON. No shutdown.	8. Disconnect wire at TB11-31. Light ON after relay reset. Replace engine monitor board.

*NOTE: Not applicable on Pennsylvania State models.

OUT-OF-SERVICE PROTECTION

Generator sets removed from service for extended periods of time should be protected from rust and corrosion. Onan recommends the following protective procedure—

For One Month

1. Run the engine at 1800 r/min and treat the upper cylinders by spraying an engine preservative oil (SAE 10) into the carburetor air intake for about two minutes. Open the throttle for a short burst of speed, then shut off the ignition and allow the engine to come to a stop while continuing to spray the oil into the carburetor air intake. Disconnect and remove battery.
2. Leave the Spark plugs installed and cover all engine openings with dust-proof caps or shields.
3. Drain the oil, water and gasoline.

For Indefinite Period

1. Drain the crankcase completely and refill with an engine preservative oil (SAE 10).
2. Run the engine until it is completely out of gasoline, then restart and run it on an unleaded, undyed gasoline for at least 10 minutes. Run the engine at 1800 r/min and treat the upper cylinders by spraying an engine preservative oil (SAE 10) into the carburetor air intake for about two minutes. Open the throttle for a short burst of speed, shut off the ignition and allow the engine to come to a stop while continuing to spray the oil into the carburetor air intake.
3. Disconnect and remove battery. Follow standard battery storage procedure. Apply film of non-conductive grease to terminal lugs.
4. Drain the oil and gasoline. Drain the water at the bottom of the radiator and side of the block.
5. Remove all grease and oil from the exterior surfaces of the engine.
6. Leave the spark plugs installed.
7. Seal all engine openings and accessories with water resistant adhesive tape. Mask off all areas to be used for electrical contact.
8. Make sure all surfaces are dry, then spray all taped openings, all engine accessories including ignition wiring, and all exterior surfaces of the engine with an ignition insulation compound.
9. Fill fuel tank to prevent condensate contaminates.
10. Provide suitable cover for entire unit.

RETURNING UNIT TO SERVICE

1. Remove cover and all protective wrapping. Remove plug from exhaust outlet.
2. Refill crankcase with correct viscosity oil.
3. Clean and check battery. Measure specific gravity (1.260 at 25° C (77° F) and verify level to be at split ring. If specific gravity is low, charge until correct value is obtained. If level is low, add distilled water and charge until specific gravity is correct. DO NOT OVERCHARGE.

WARNING

Do not smoke while servicing batteries. Explosive gases are emitted from batteries in operation. Ignition of these gases can cause serious personal injury.

4. Connect batteries.
5. Fill coolant system as described under *PRESTART SERVICE*.
6. Verify that no loads are connected to the generator.
7. Start engine.

After engine has started, excessive blue smoke will be exhausted and the engine will run rough until the rust inhibitor or oil has burned away.

8. After start, apply load to at least 50% of rated capacity.
9. Check all gauges to be reading correctly. Unit is ready for service.

BATTERY, HOT LOCATION

Batteries will self discharge very quickly when installed where the ambient temperature is consistently above 90° F (32.2° C), such as in a boiler room. To lengthen battery life, dilute the electrolyte from its normal 1.275 specific gravity reading at full charge to a 1.225 reading. The cranking power is reduced slightly when the electrolyte is so diluted, but if the temperature is above 90° F (32.2° C), this should not be noticed. The lengthened battery life will be worth the effort.

1. Fully charge the battery.
2. With the battery still on charge, draw off the electrolyte above the plates in each cell. DO NOT ATTEMPT TO POUR OFF; use an hydrometer or filler bulb and dispose of it in a safe manner. Avoid skin or clothing contact with the electrolyte.
3. Refill each cell with distilled water, to normal level.
4. Continue charging for 1 hour at a 4- to 6-hour rate.
5. Test each cell. If the specific gravity is still above 1.255, repeat steps 2, 3, and 4 until the reading is reduced to 1.225. Usually, repeating steps twice is sufficient.

GENERAL MAINTENANCE

GENERAL

Establish and adhere to a definite schedule of maintenance inspection and servicing, application and environment being the governing factors in determining such a schedule. If your set is a prime power application, base your schedule on operating hours. Use the running time meter to log hours run; maintain an accurate record of hours and service for warranty support.

A set on stand-by duty will need servicing at times other than those recommended by Onan and the engine manufacturer. Refer to Ford manual for engine services and maintenance procedures. Adjust your schedule to satisfy the following conditions—

- Continuous duty (prime power)
- Standby power
- Extremes in ambient temperature
- Exposure to elements
- Exposure to salt water or sea air
- Exposure to dust, sand, etc.

Consult with your ONAN distributor or dealer for a schedule of maintenance and service more suitable to the unique environment and application of your set.

WARNING Before commencing any maintenance work on the engine, generator, control panel, automatic transfer switch or associated wiring, disconnect batteries. Failure to do so could result in damage to the unit or serious personal injury in the event of inadvertent starting.

TABLE 5. OPERATOR MAINTENANCE SCHEDULE

MAINTENANCE ITEMS	OPERATIONAL HOURS			
	10	50	200	400
Inspect Complete Set for Leaks, etc.	x1			
Check Engine Oil Level	x1			
Check Radiator Coolant Level	x1			
Check Fuel	x1			
Check Governor Oil Level*		x		
Check Air Cleaner (Clean or Replace as Necessary)		x2		
Check Electrolyte Level of Battery		x7		
Stop-Solenoid Linkage, Lubricate Governor Linkage*		x2		
Change Engine Oil & Filter		x2		
Check All Hardware, Fittings, Clamps, Fasteners, etc.		x4		
Adjust Drive Belt Tension			x3	
Change Governor Oil*			x	
Clean Fuel Lift Pump			x	
Clean Sediment Bowl & Filter			x	
Check Starter			x5	
Clean & Inspect Battery Charging (DC) Alternator			x	
Check AC Generator			x6	
Inspect Spark Plugs, Replace if Necessary			x	
Replace Fuel Filter Element				x2
Adjust Valve Clearances				x
Inspect Ign. Points, Replace if Necessary*				

x1 - After every run or exercise period.

x2 - Perform more often in extremely dusty conditions.

x3 - Adjust to 1/2-inch (12.5 mm) depression between pulleys.
Refer to Ford engine manual.

x4 - Or every 3 months.

x5 - Oil front bearing sparingly; check brushes.

x6 - Check brushes (if installed), replace if worn to 5/8-inch (15.9 mm) or if damaged. DO NOT LUBRICATE.

x7 - Or every two weeks.

* - See Figure 36.

NOTE: The above schedule is a minimum requirement.

ENGINE

General: Basic maintenance procedures are contained within the Ford manual, which should be used in conjunction with the set manual, except in such cases where instructions state otherwise. Then, the new information unique to the EK/EM set shall take precedence.

Air Filter: Remove wing nut in center of filter cover. See Figure 24. Remove cover and filter. Tap filter on a flat surface to remove adherent dirt. Place a light source inside the filter and inspect for free air passage. If necessary, apply a low pressure air source (30-psi [207 kPa] OSHA) to the inside of the filter to remove as much dirt as possible. Inspect interior housing. Vacuum clean if dirty, or remove housing and wipe clean.

CAUTION Do not clean filter housing while still installed. Loose dirt entering intake could damage carburetor or engine.

Replace air filter every 50 hours of operational time; more often in extremely dusty conditions.

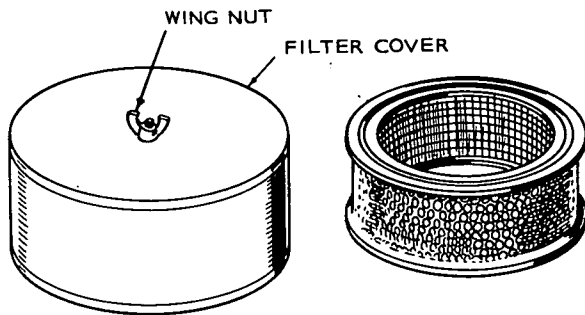

FIGURE 24. AIR CLEANER

Engine Oil Filter: Spin-off type, should be replaced with every oil change, at 50 hours of operational time.

Remove and discard old filter, wipe oil from exposed adapter recess. See Figure 25. Coat gasket of new filter with clean lubricating oil and place in position on adapter. Hand-tighten filter until gasket contacts adapter face then advance one-half turn. DO NOT OVERTIGHTEN.

Clean all oil residues from engine, then fill crankcase. Refer to *Prestart Servicing*. Run engine and check for oil leaks; make necessary repairs. Note oil change in engine logbook.

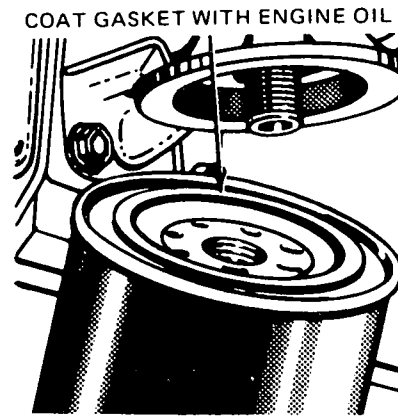

FIGURE 25. OIL FILTER ASSEMBLY

Fuel Filter: Replace filter every 200 operational hours or as conditions require. Unscrew the filter housing from the fuel pump (Figure 26) and remove the filter element and gasket. Discard the element and gasket. Clean the filter housing in a petroleum cleaning solvent.

Place a new filter element over the spout in the fuel pump valve housing cover.

Be sure to use the proper type element for the installation.

Coat a new gasket with a light engine oil and position the gasket on the filter housing. Screw the filter housing onto the fuel pump. Hand tighten the filter until the gasket contacts the pump, and then advance it 1/8 turn. Start the engine and check for leaks.

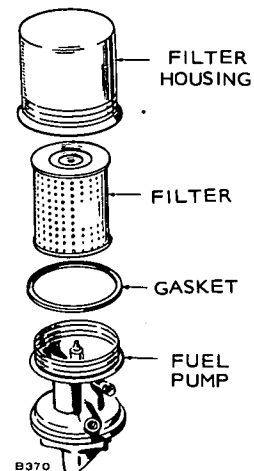

FIGURE 26. FUEL FILTER ASSEMBLY

Crankcase Ventilation (PCV) Valve: Push fit in valve rocker cover. Remove and clean at every oil change. After cleaning, shake valve to ensure ball is free, then reinstall.

CARBURETORS

The following carburetors were installed by ONAN for a specific application and engine output. Use these instructions and adjustment procedures in preference to those given in the Ford engine manual.

Carburetor, Gasoline: Carburetors have main and idle adjusting needle valves. The main adjusting needle, at the bottom of the carburetor, affects operation at heavier load conditions. The idle adjusting needle, at the side of the carburetor, affects operation at light and no load conditions. For location of adjustments, see Figure 27.

Under normal circumstances, factory carburetor adjustments should not be disturbed. If adjustments have been changed, an approximate setting of 1-1/2 turn open for idle needle and one turn open for main needle will permit starting. Adjust temporarily for smoothest running. Allow engine to thoroughly warm up before making final adjustment.

To adjust "idle" (no load) needle, see that no loads are connected to the generator. Slowly turn idle adjusting needle out until engine speed drops slightly. Turn needle in just to the point where speed returns to normal.

To adjust main needle, apply a full electrical load. Turn the main needle in until engine speed begins to drop. Slowly turn needle out until speed no longer rises. Try various electrical loads. If engine speed

fluctuates at any load, turn main adjusting needle out slightly. Do not turn out more than 1/2 turn beyond original full load setting. If stable speed cannot be obtained by such carburetor adjustment, a change in governor sensitivity adjustment will probably be necessary.

Combination Carburetor, Gas Operation: If the engine is equipped with a combination carburetor (Figure 28), see that the gasoline shut-off valve is closed. The electric choke must be adjusted so that the adjustable cover is turned 10 to 12 notches counterclockwise from the "*" mark. When properly adjusted, the electric choke will be completely open even at very low temperatures.

Gas fuel main adjustment should be made at full load only.

Carburetor, Gas: Engines equipped for natural gas operation use a gas carburetor with combined regulator. Carburetor adjustments are the same as the combination gas-gasoline carburetor.

Conversion kits are available for LPG operation (Figures 30 and 31). Contact your local Onan representative for information. Give complete Model, Spec No. and Serial No. of set when requesting conversion information.

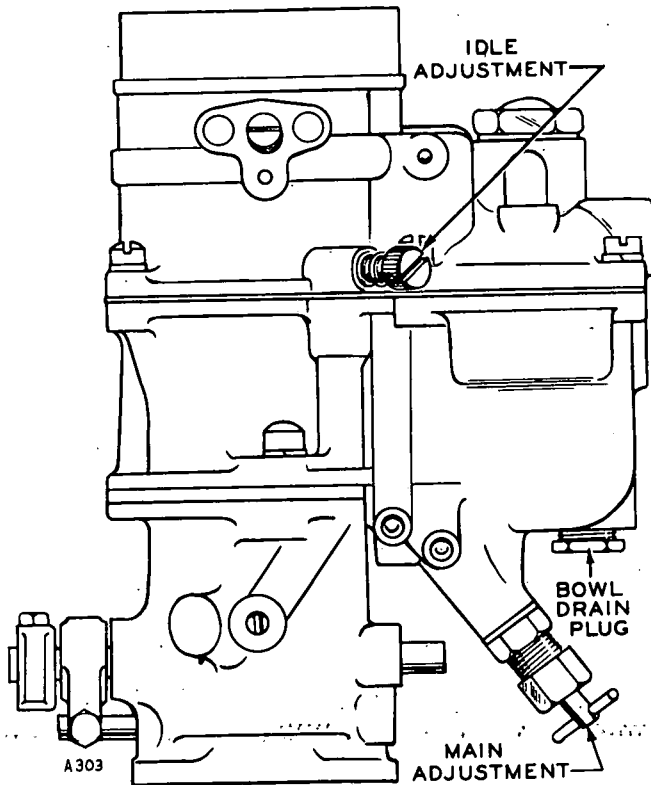

FIGURE 27. GASOLINE CARBURETOR

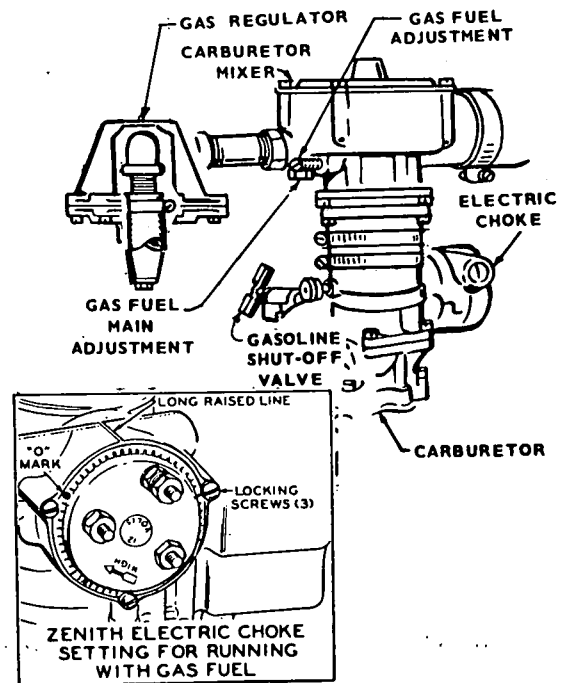

FIGURE 28. COMBINATION CARBURETOR

Electric Choke: A 12 volt electric choke (Figure 29) with vacuum booster is used on all engines. The adjustable choke cover is held in place by three screws. Perimeter of the cover is divided into sections by small raised marks. One mark is labeled zero and the twelfth mark from zero is labeled with an asterisk (*), which indicates normal adjustment setting. A long raised line on top of the choke housing is used as the reference mark. Normal setting for the choke is made when the asterisk mark lines up with reference line.

If overchoking occurs, loosen three locking screws and turn choke cover slightly to the left (counterclockwise). Do not turn very far. One or two notches will usually be sufficient. Tighten locking screws. To increase choking action, turn choke cover slightly to the right (clockwise). Retighten cover screws.

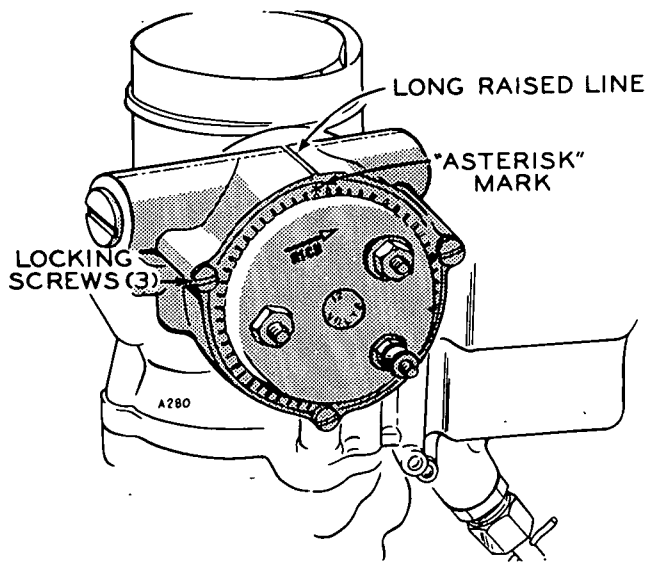

FIGURE 29. ELECTRIC CHOKE

Anti-Dieseling Control: Normally factory adjustment should not be changed. Adjustment procedure is included with governor adjustment.

The anti-dieseling control is a device to hold the throttle closed during engine shutdown. This ensures prompt stopping and prevents backfiring. A spring and linkage hold the throttle closed during shutdown. A solenoid is energized to overcome spring tension and permits the governor to open the throttle for engine running.

Governor (Includes Anti-dieseling Control): The governor controls the speed of the engine, and therefore the frequency of the voltage. Engine speed affects AC output voltage. Use either a tachometer or frequency meter to check engine speed for proper governor adjustment.

1. **Governor linkage**—With engine stopped, throttle held wide open, and tension on governor spring, adjust the governor linkage length by rotating the ball joint on the link so that the throttle stop lever clears the stop pin by not less than 1/32".
2. **Anti-diesel control**—Move override and no load stops (set screws on wire link, Figure 32) away from override lever so that they have no effect on engine speed.
3. **Warm up**—Start the engine and allow it to reach operating temperature.
4. **Speed**—With no electrical load connected, adjust the speed adjusting screw to obtain 1890 r/min (63 hertz) for a 60 hertz set or 1590 r/min (53 hertz) for a 50 hertz set. Apply a full electrical load. The speed drop from the no load figure should be no more than 90 r/min (3 hertz) and no less than 45 r/min (1-1/2 hertz). An incorrect speed drop from no load to full load necessitates a sensitivity adjustment.

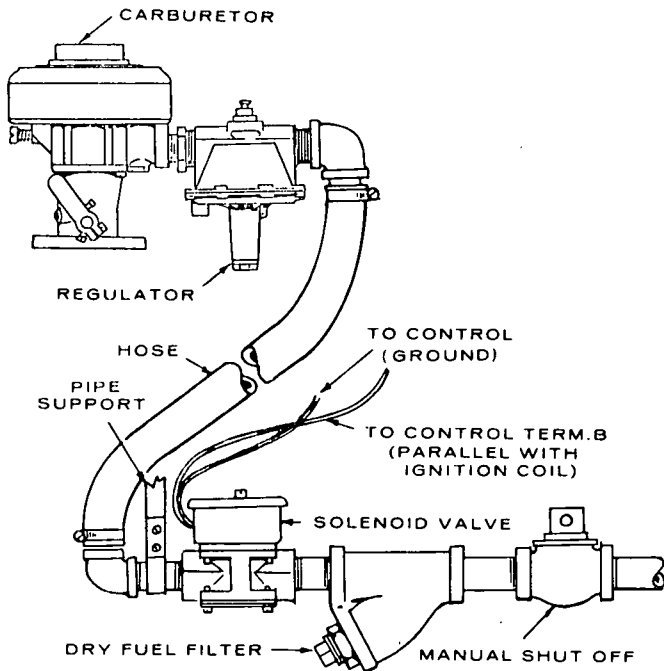

FIGURE 30. LPG VAPOR WITHDRAWAL

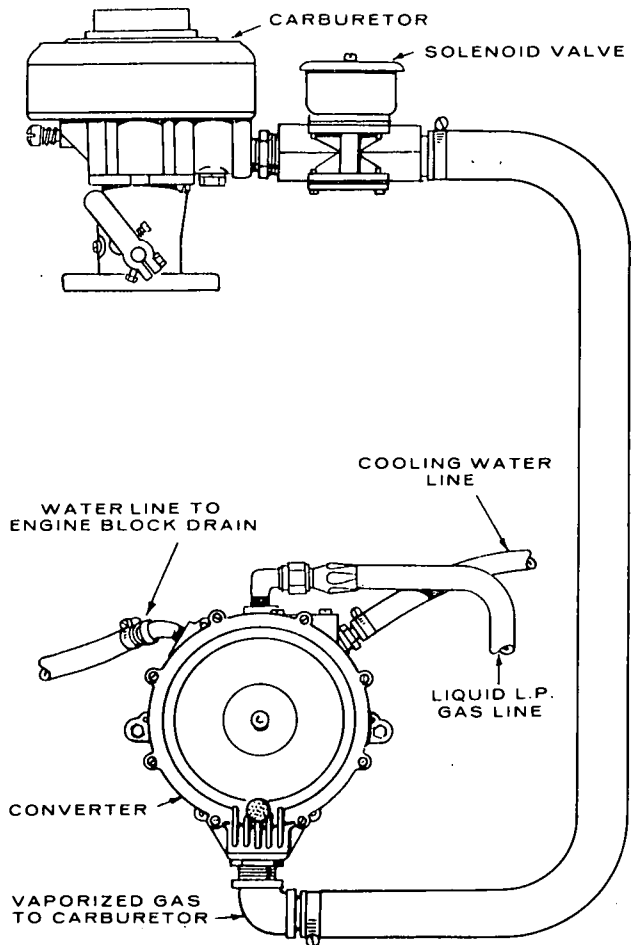

FIGURE 31. LPG LIQUID WITHDRAWAL

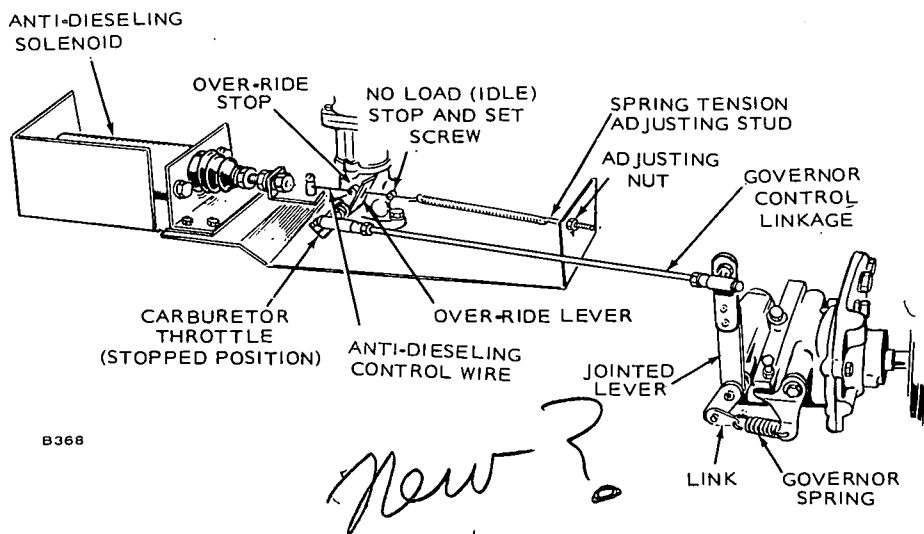

FIGURE 32. ANTI-DIESEL CONTROL

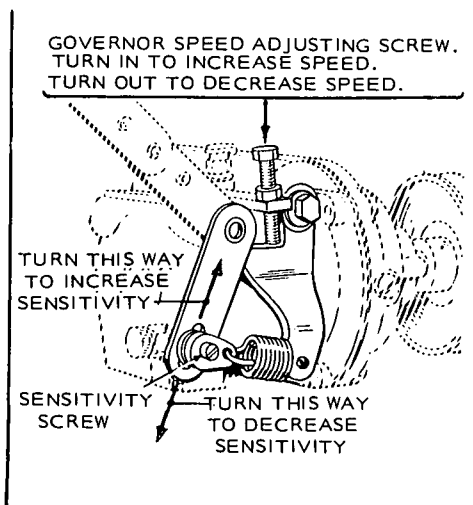

FIGURE 33. GOVERNOR ADJUSTMENT

5. **Sensitivity**—If engine tends to hunt (alternately increase and decrease speed) under load conditions, increase sensitivity screw on which the spring link pivots.

Any change in the setting of the sensitivity screw will require correcting the speed screw adjustment. Turning the sensitivity screw clockwise causes a slight speed increase which can be corrected by turning the speed screw slightly counterclockwise to decrease spring tension.

6. **General**—Be sure that all lock nuts are tightened as adjustments are completed. Governors cannot operate properly if there is any binding, sticking, or excessive looseness in the connecting linkage or carburetor throttle assembly. A lean fuel mixture, or a cold engine may cause hunting.

7. **Output**—Check the AC output voltage.

8. **Throttle Stop**—With the engine stopped, see that the throttle stop lever screw (attaching the override lever, Figure 34) engages the carburetor throttle stop pin by $1/4$ to $1/2$ turn. This can be done by backing off the screw until it just clears the stop pin, then turning in $1/4$ to $1/2$ turn. This provides a "cracked open" throttle for good starting characteristics. Do not adjust the screw so far as to cause the engine to "diesel" and refuse to stop, thus defeating the purpose of the anti-dieseling control.

9. **Anti-dieseling control**—

- See that the wire linkage is securely attached to the solenoid plunger. Do not shorten or lengthen this connection unless the spring tension at the opposite end cannot be fully adjusted by its stud. See Figure 32.
- Set the override stop (located nearer the solenoid) on the wire linkage to about $1/32$ inch from the slotted override lever on the carburetor so that it does not interfere with wide open throttle when the solenoid is fully engaged (plunger all-the-way in, as when engine is running).
- See that anti-dieseling control spring tension is just enough to positively bend governor's jointed lever and hold throttle closed during stopping. Spring tension adjusting stud serves also to rotate spring as necessary to hold linkage stops horizontally to engage flat against override lever.
- Set no load stop (set screw, located nearer the spring) on wire linkage $1/32$ inch away from override lever while set is running at rated speed with electrical load removed (no load). Start and stop set to check adjustment.

Be sure that all lock nuts are tightened as adjustments are completed.

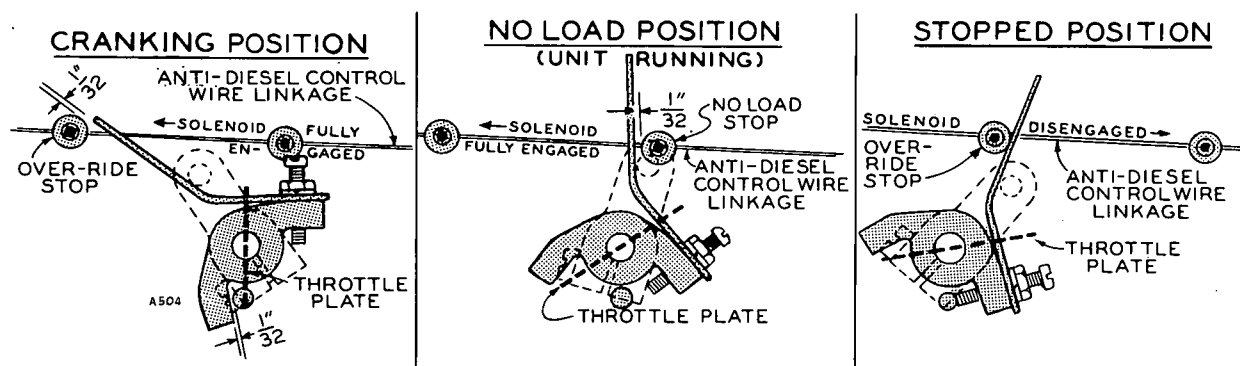

FIGURE 34. THROTTLE STOP

Drive Belt Adjustment: Separate belts are used to drive fan, governor and alternator (Figure 35). Maintain correct adjustment of these belts to provide proper engine cooling and alternator output. Check belts for cracks and wear occasionally, and replace when necessary.

To adjust fan belt, loosen fan bracket screws, then move bracket up or down until a deflection of 1/2 inch (13 mm) is obtained between crankshaft pulley and fan pulley, with light thumb pressure on the belt.

To adjust alternator or governor belt, loosen link clamp screw and the mounting bolts, move alternator or governor toward or away from engine until a deflection of 1/2 inch (13 mm) is obtained between pulleys, with light thumb pressure on belt.

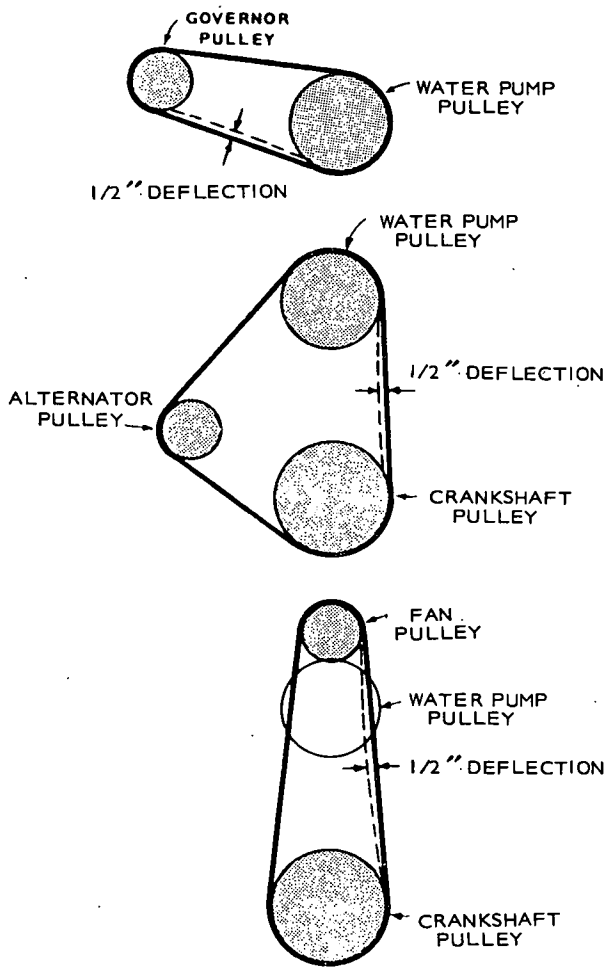

FIGURE 35. DRIVE BELT ADJUSTMENT

BATTERIES

Check the condition of the starting batteries at least every two weeks. See that connections are clean and tight. A light coating of grease will retard corrosion at terminals. Keep the electrolyte at the proper level above the plates by adding distilled water.

TUNE UP

ONAN suggests that the following specifications for tune up be used in preference to those given in the Ford manual. This is due to a difference in r/min (no idle speed) and removal of automatic vacuum advance.

TABLE 6. TUNE-UP SPECIFICATIONS

ADJUSTMENTS	EK SERIES	EM SERIES
Spark Plug Gap, All Models	.028"	.028"
Spark Plug Gap, Gas Only Models	.025"	.025"
Ignition Points — Gap Setting	.024" - .026"	.024" - .026"
Dwell Angle	35° - 39°	35° - 39°
Valve Clearance Setting	Zero Lash	Zero Lash

CONNECTIONS (Fuel, Exhaust, etc.)

Operator should periodically make a complete visual inspection of the unit while running at rated load.

Some of the things to check for are as follows:

1. Check fuel and oil lines for possible leakage.
2. Inspect exhaust lines and mufflers for possible leakage and cracks.
3. Periodically or daily drain moisture from condensation traps.
4. Inspect water lines and connections for leaks and security.
5. Inspect electrical wires for security.

MAINTENANCE

Refer to Table 5 for Operator Maintenance Schedule.

Governor oil level should be even with bottom of the oil level plug. When adding oil to the governor, the oil should just start to flow out of the oil level plug hole. Do not overfill.

AC GENERATOR

There are no brushes, brush springs or collector rings on these generators, therefore they require very little servicing. Periodic inspections, to coincide with engine oil changes, will ensure good performance.

Inspection: Inspect generator and control box for loose or broken wires and parts. Check diodes and printed circuit boards for excessive dust, grease or moisture. Blow these assemblies out periodically with filtered, low pressure, compressed air.

CAUTION

Excessive foreign matter on diodes and heat sinks will cause overheating and possible failure.

Generator Bearing

Inspect the bearing for evidence of outer case rotation every 1000 hours while the unit is running.

If unit is used for "prime power," replace the bearing every 10,000 hours or two years. If the unit is used for "standby," replace the bearing every five years.

Deterioration of the bearing grease due to oxidation makes this replacement necessary.

If generator requires major repair or servicing, contact an authorized Onan dealer or distributor.

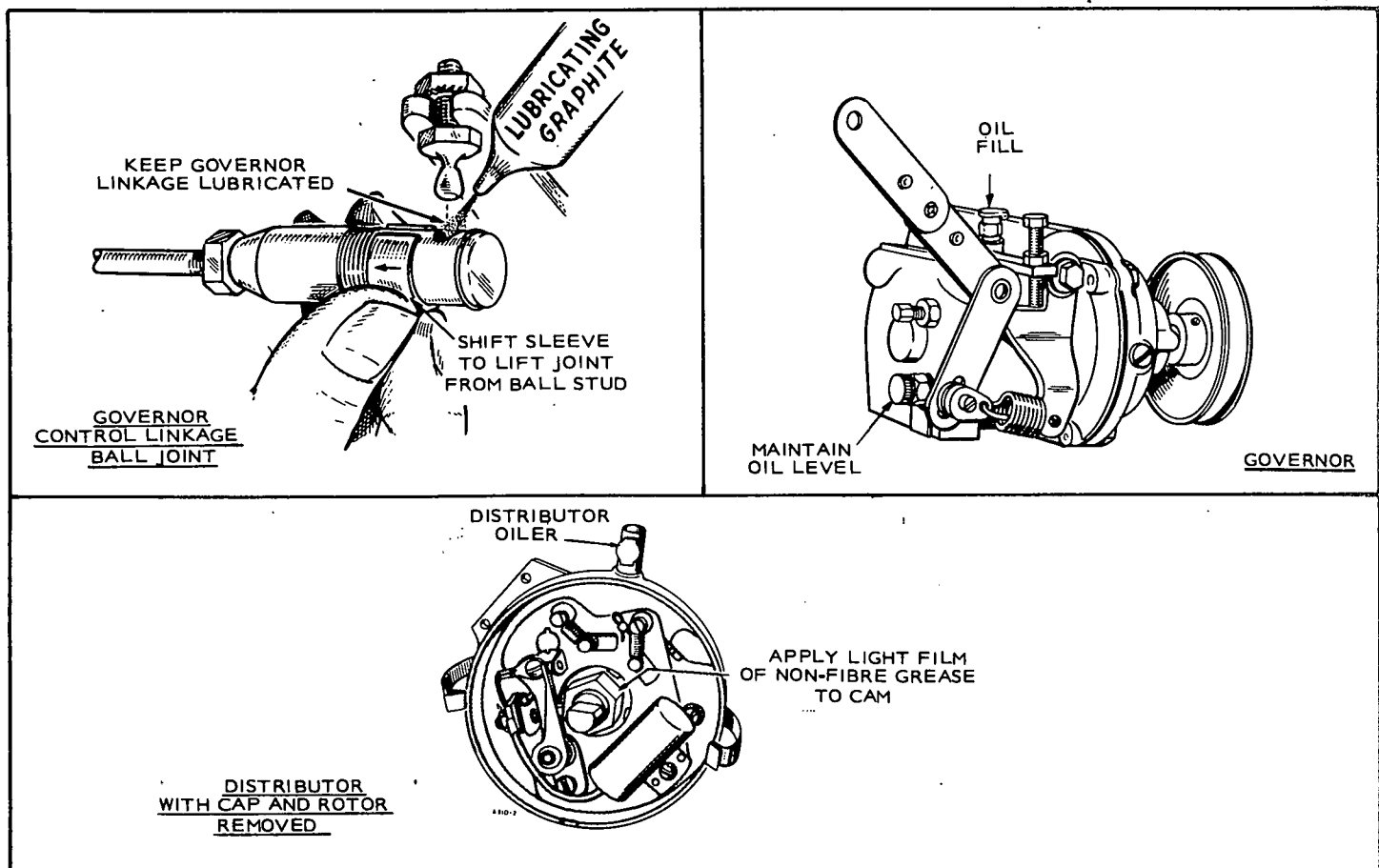

FIGURE 36. MAINTENANCE

PARTS CATALOG NOTICE!

ITEMS REFERENCED AS **OPTIONAL** INDICATE PART IS FACTORY INSTALLED AND MAY NOT BE APPLICABLE TO ALL MODELS. FOR FIELD CONVERSIONS ADDITIONAL PARTS ARE USUALLY REQUIRED.

INSTRUCTIONS FOR ORDERING REPAIR PARTS

ONAN PARTS

All parts in this list are Onan parts. For Onan parts or service, contact the dealer from whom you purchased this equipment or your nearest authorized service station. To avoid errors or delay in filling your order, please refer to the Onan nameplate and give the complete MODEL, SPECIFICATION and SERIAL NUMBER.

Onan ELECTRIC GEN SET			
MODEL <input type="text"/>			
SERIAL NO. <input type="text"/>			
IMPORTANT ALWAYS GIVE ABOVE NOS. WHEN ORDERING PARTS			
CONTINUOUS <input type="text"/>		RATING	
HERTZ-60 RPM - 1800			
3 PHASE		1 PHASE	
KW <input type="text"/>	KVA <input type="text"/>	KW <input type="text"/>	KVA <input type="text"/>
VOLTS 120/208 127/220 139/240 120/240 240/416			
AMPS <input type="text"/>			
VOLTS 254/440 277/480 347/600 120/240			
AMPS <input type="text"/>			
BAT. <input type="text"/> VOLTS			
MANUFACTURED BY ONAN DIV OF ONAN CORPORATION MINNEAPOLIS, MINN 55432, U.S.A. FOR ELECT. EQUIPMENT ONLY 			

FORD PARTS

All Ford parts must be ordered from the Ford Motor Company of Dearborn, Michigan, or your nearest authorized distributor. When ordering parts, refer to the Ford nameplate and give the complete SERIAL, TYPE and OPTIONS NUMBER.

<i>Ford</i> REG. U.S. PAT. OFF.	
INDUSTRIAL ENGINE	
SERIAL	
<input type="text"/>	
TYPE	OPTIONS
<input type="text"/>	<input type="text"/>

This catalog applies to the standard EK and EM generator sets as listed below. These sets are powered by a Ford engine (see Ford manual). Engine parts modified or added by Onan will be in this list and have Onan part numbers. These supersede similar parts listed in the Ford manual. Onan parts are arranged in groups of related items and are identified by a reference. All parts illustrations are typical. Using the Model and Spec No. from the set nameplate, select the Parts Key No. (1, 2, etc., in the last column) that applies to your set. This Parts Key No. represents parts that differ between models. Unless otherwise mentioned, parts are interchangeable. Right and left sides are determined by facing the front end of the engine.

ELECTRIC GENERATING SET DATA TABLE

MODEL AND SPEC NO.*	ELECTRICAL DATA				PARTS KEY NO.
	WATTS	HERTZ	PHASE	WIRE	
25.0EK-515R/	25,000	50	£	12	1
30.0EK-3R/	30,000	60	1	3	1
30.0EK-15R/	30,000	60	£	12	1
30.0EK-9XR/	30,000	60	3	4	1
37.5EM-515R/	37,500	50	£	12	2
45.0EM-3R/	45,000	60	1	3	2
45.0EM-15R/	45,000	60	£	12	2
45.0EM-9XR/	45,000	60	3	4	2
Pennsylvania Approved Sets	See special parts list following the main parts list.				

* - The Specification Letter advances (A to B, B to C, etc.) with manufacturing changes.

£ - These sets are reconnectible; refer to Specifications (Generator Details).

REPLACEMENT ENGINE

100-0904

1

EK & EM (Ford Motor Company Model C5PG-6005-A, Spec SO-30B)

General Description:

Includes — Complete Cylinder Block, Oil Pan, Water Pump, Oil Filter, Fuel Pump and Filter, Starter Motor, Spark Plugs, Front Support, Flywheel Housing Plate, Thermostat, and Alternator Mounting Brackets.

Excludes — Carburetor, Air Cleaner, Charge Generator, Oil Pressure, Water Temperature Gauge Senders, Oil Pressure Switch, High Water Temperature Cut Off Switch, Anti-Dieseling Control, Radiator, Fan Blades & Belts, Muffler and Exhaust Tube.

* - Engine listed is for Standard Spec 1 (Radiator Cooled) generator sets, for all other models refer to factory. For EK generator sets Spec A through F also order 141-0627 Carburetor and 145-0467 Restrictor Plate.

COOLING, OIL DRAIN AND EXHAUST GROUP

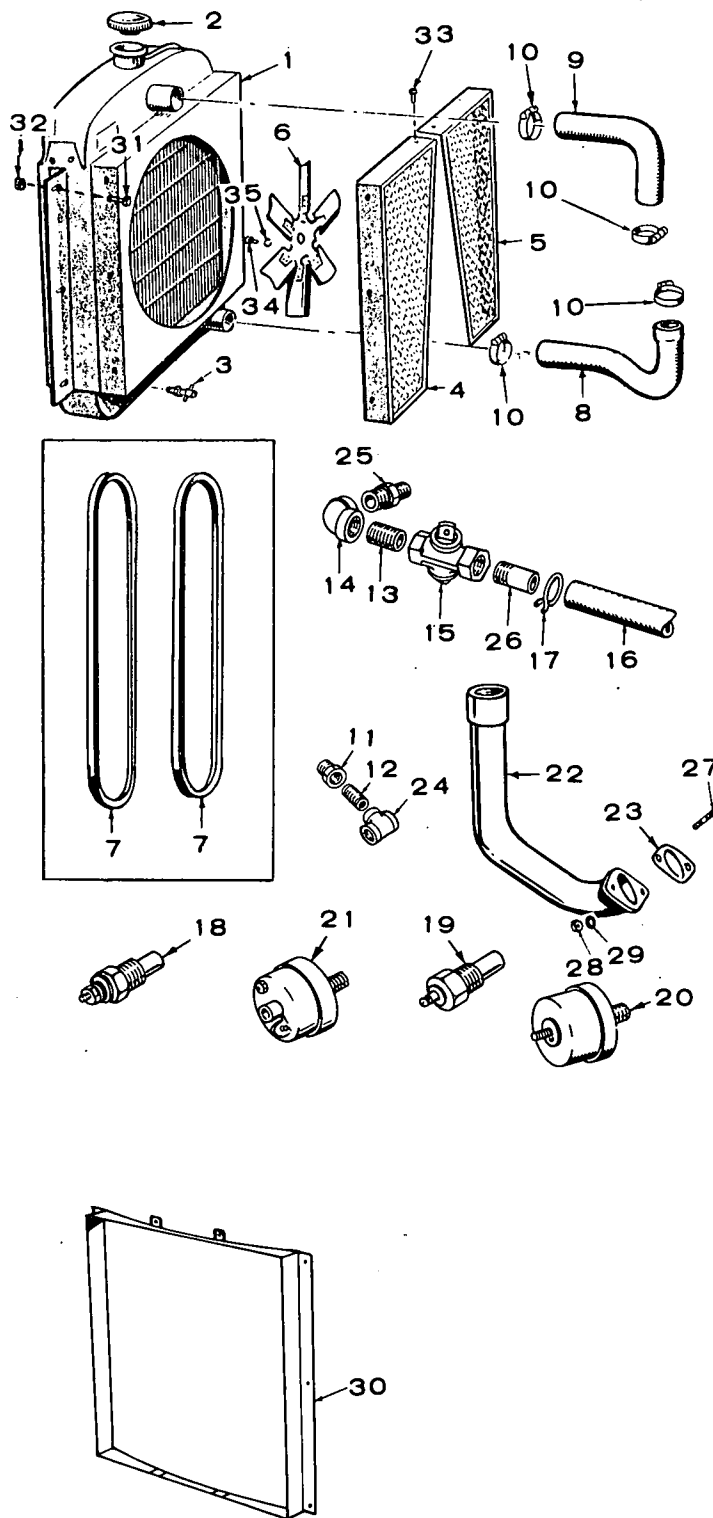

REF. NO.	PART NO.	QTY. USED	PART DESCRIPTION
1	RADIATOR		
	130-0660	1	Key 1
	130-0604	1	Key 2
2	130-0449	1	Cap, Radiator
3	504-0028	1	Valve, Radiator Drain
4	130-0352	1	Guard, Fan (Right Hand)
5	130-0351	1	Guard, Fan (Left Hand)
6	130-0355	1	Blade, Fan
7	BELT		
	511-0075	1	Fan
	511-0074	1	Water Pump
8	503-0490	1	Hose, Lower - Radiator
9	503-0491	1	Hose, Upper - Radiator
10	CLAMP, HOSE		
	503-0311	3	2-1/8 x 1/2"
	503-0365	1	2-1/4 x 1/2"
11	505-0007	2	Bushing, Reducer (1/4 x 1/8")
12	505-0098	1	Nipple, Close (1/8 x 3/4") - Low Oil Pressure Switch
13	505-0101	1	Nipple, Pipe - Oil Drain
14	505-0039	1	Elbow, Oil Drain
15	504-0030	1	Valve, Oil Drain
16	503-0484	1	Hose, Oil Drain
17	503-0131	1	Clamp, Hose - Oil Drain
18	193-0104	1	Sender, Water Temperature
19	309-0178	1	Switch, Water Hi-Temperature
20	193-0108	1	Sender, Oil Pressure
21	309-0169	1	Switch, Low Oil Pressure
22	155-1107	1	Tube, Exhaust
23	155-0923	1	Gasket, Exhaust Tube
24	505-0059	1	Tee (1/8") - Low Oil Pressure Switch
25	102-0652	1	Adapter, Oil Drain
26	505-0135	1	Nipple, Half - Oil Drain
27	520-0404	2	Stud, Exhaust Flange
28	870-0203	2	Nut, Hex (7/16-20)
29	850-0055	2	Washer, Lock - Spring (7/16")
30	405-1054	1	Flange, Adapter - Air Duct - Optional
31	821-0014	6	Screw, Cap - Lockinghead - (5/16-18 x 1/2")
32	870-0113	6	Nut, Retainer (5/16-18)
33	815-0181	8	Screw, Tapping - Lockinghead - (#18 x 3/4")
34	800-0026	4	Screw, Cap - Hexhead - (#18 x 3/4")
35	850-0045	4	Washer, Lock - Spring (5/16")

ANTI-DIESELING GROUP

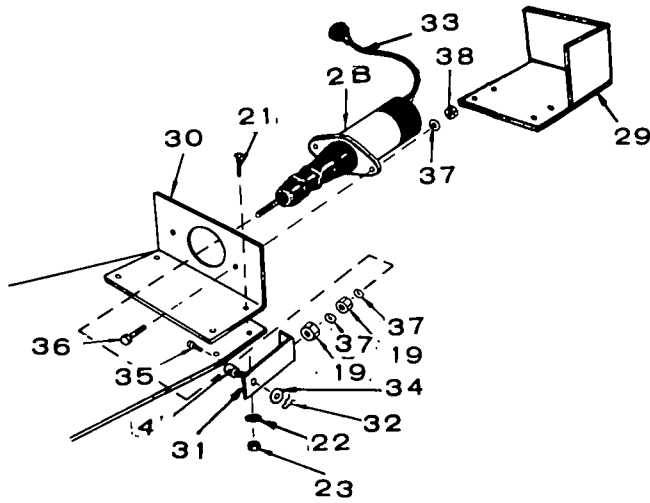
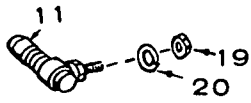
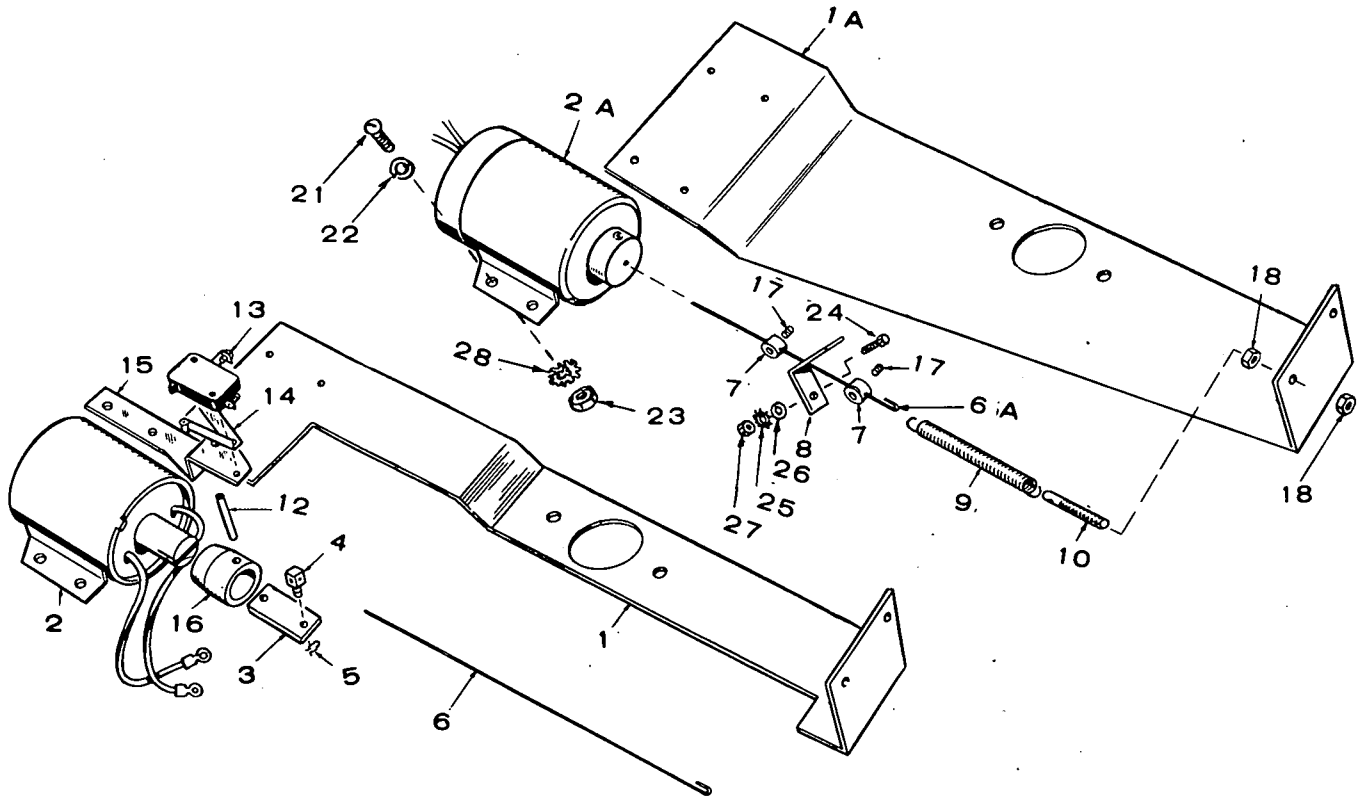

ANTI-DIESELING GROUP

REF. NO.	PART NO.	QTY. USED	PART DESCRIPTION	REF. NO.	PART NO.	QTY. USED	PART DESCRIPTION
	BRACKET, ANTI-DIESELING CONTROL			23	860-0008	4	Nut, Hex - Solenoid Mounting (8-32)
1	145-0182	1	Early Spec C Models				
1A	145-0422	1	Use Began During Spec C	24	815-0134	1	Screw, Machine (Fillister) - Override Arm Mounting (8-36 x 3/4")
	SOLENOID, ANTI-DIESELING						
2	307-0259	1	Early Spec C Models				
2A	307-1093	1	Use Began During Spec C through E	25	853-0005	1	Washer, Lock (External Shakeproof) - Override Arm Mounting (#8)
2B	307-1356	1	Begin Spec F				
3	145-0164	1	Extension, Solenoid Arm (Early Spec C Models)	26	526-0048	1	Washer, Flat - Override Arm Mounting (.172" ID x 3/8" OD x 1/32" THK) - Brass
4	152-0155	1	Swivel, Choke Lever				
5	516-0059	1	Pin, Cotter (Early Spec C Models)	27	870-0055	1	Nut, Hex - Override Arm Mounting (8-32)
	LINK, THROTTLE						
6	145-0166	1	Early Spec C Models	28	856-0002	1	Washer, Lock (External/Internal Shakeproof) - Override Arm Mounting (#8)
6A	145-0421	1	Use Began During Spec C				
7	145-0165	2	Stop, Throttle	29	307-1327	1	*Shield, Anti-Dieseling Solenoid (Begin Spec F)
8	145-0163	1	Arm, Override	30	307-1323	1	*Bracket, Anti-Dieseling Solenoid Mounting (Begin Spec F)
9	145-0158	1	Spring, Throttle				
10	150-0096	1	Stud, Governor Adjusting	31	307-1330	1	*Bracket, Solenoid (Begin Spec F)
11	150-0638	1	Joint, Ball	32	516-0059	1	*Pin, Cotter - Swivel Choke Lever (Begin Spec F)
12	516-0086	1	Pin, Roll (Early Spec C Models)	33	334-0028	1	*Lead, Anti-Dieseling Solenoid
13	309-0155	1	Switch, Micro (Early Spec C Models)	34	526-0006	2	*Washer, Flat - Arm Swivel Mounting (15/64" ID x 1/2" OD x 3/64" THK)
14	309-0133	1	Actuator (Early Spec C Models)	35	815-0104	1	*Screw, Machine (Fillister Head) - 8-32 x 5/16"
15	309-0131	1	Bracket, Micro Switch (Early Spec C Models)	36	800-0003	2	*Screw, Cap (Hexhead) - Solenoid to Bracket Mounting (1/4-20 x 1/2")
16	309-0132	1	Cam, Micro Switch (Early Spec C Models)				
17	803-0002	2	Screw, Set (Socket) - Throttle Stop - (8-32 x 3/16")	37	850-0040	4	*Washer, Lock (Spring) - Solenoid to Bracket Mounting (1/4")
18	870-0053	2	Nut, Hex - Governor Adjusting Stud (10-32)	38	862-0001	2	*Nut, Hex - Solenoid to Bracket Mounting (1/4-20)
19	115-0025	1	Nut, Hex - Ball Joint - (1/4-28)				
20	850-0045	1	Washer, Lock (Spring) - Ball Joint - (1/4")				
21	812-0079	4	Screw, Cap (Roundhead) - Solenoid Mounting - (8-32 x 1/2")				
22	850-0025	4	Washer, Lock (Spring) - Solenoid Mounting (#8)				

* - These Parts were used on some Spec E Models above Serial #173734205

GOVERNOR, ALTERNATOR, AND IGNITION COIL GROUP

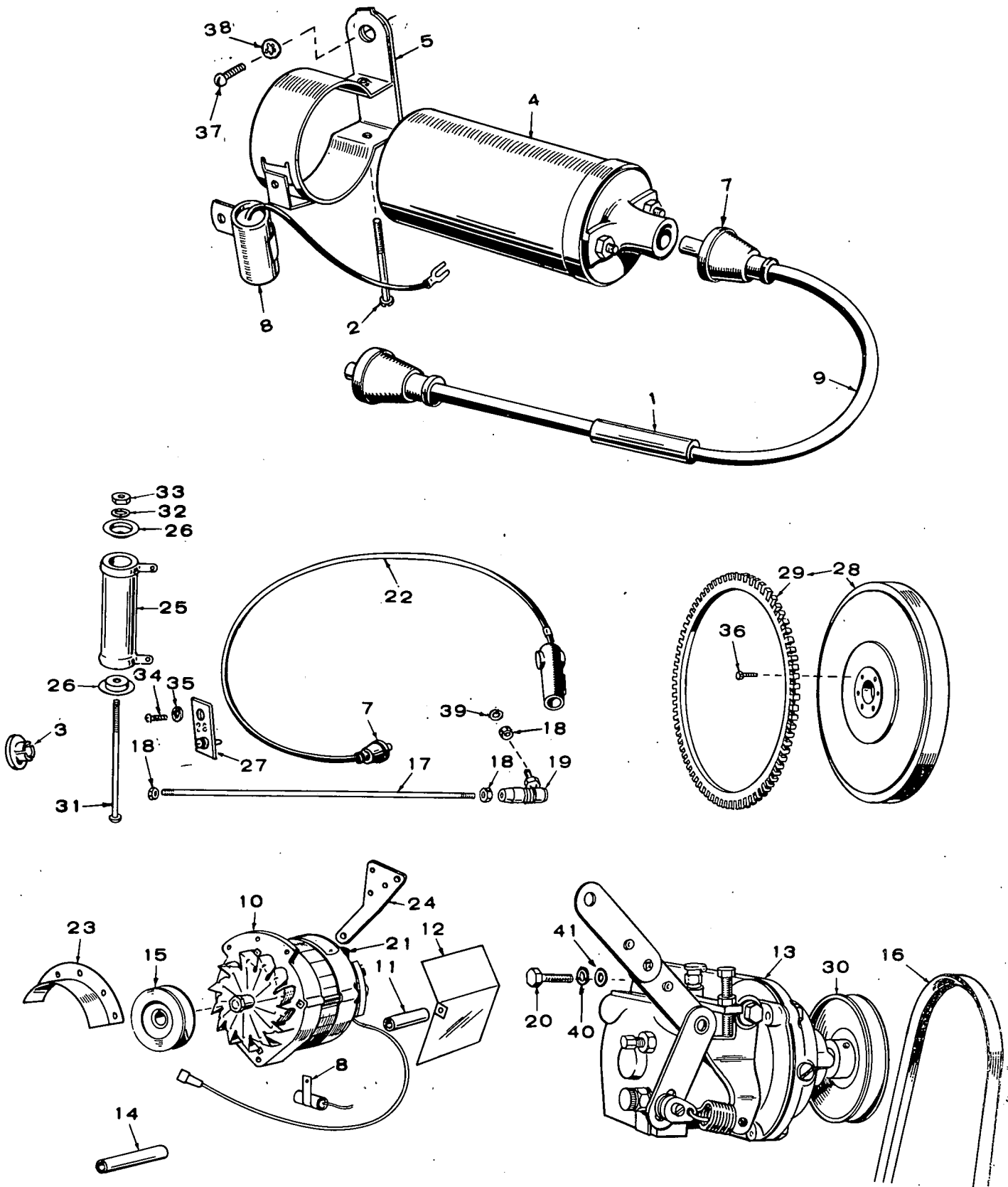

GOVERNOR, ALTERNATOR, AND IGNITION COIL GROUP

REF. NO.	PART NO.	QTY. USED	PART DESCRIPTION	REF. NO.	PART NO.	QTY. USED	PART DESCRIPTION
1	314-0006	1	Suppressor, Distributor	23	191-0725	1	Guard, Alternator Belt
2	166-0286	1	Screw, Coil Bracket	24	151-0316	1	Bracket, Governor
3	517-0090	1	Plug, Distributor Vacuum Advance	25	304-0045	1	Resistor, Fixed - Early Spec C Models
4	166-0278	1	Coil, Ignition	26	304-0015	2	Washer, Centering - Resistor
5	160-1045	1	Bracket, Coil	27	332-1292	1	Bracket Assembly, Terminal
7	160-0558	8	Nipple, Ignition Cables	28	104-0719	1	Flywheel, Includes Ring Gear
8	312-0058	2	Condenser, (1) Coil, (1) Alternator	29	104-0723	1	Gear, Ring
9	167-1528	1	Cable, Coil to Distributor	30	512-0051	1	Pulley, Governor Drive
10	191-0665	1	*Alternator (Motorola #70D44039B)	31	813-0118	1	Screw (10-32 x 4-1/2") - Resistor Mounting
11	191-0571	1	Spacer, Alternator Mounting	32	850-0030	1	Washer, Lock - Spring (#10)
12	191-0578	1	Heat Shield, Alternator	33	870-0053	1	Nut, Hex (10-32)
13	151-0312	1	**Governor	34	800-0026	1	Screw, Cap - Hexhead - (5/16-18 x 3/4")
14	191-0716	1	Spacer, Alternator	35	850-0045	1	Washer, Lock - Spring (5/16")
15	191-0623	1	Pulley, Alternator	36	104-0745	6	Bolt, Flywheel Mounting
16	511-0077	1	Belt, V (Governors on sets with air cooled exhaust manifold)	37	815-0190	1	Screw, Cap - Roundhead - (8-32 x 3/8")
16	511-0078	1	Belt, V (Governors on sets with water cooled exhaust manifold)	38	854-0007	1	Washer, Lock - Internal - (#8)
17	520-0214	1	Stud, Linkage	39	850-0040	1	Washer, Lock - Spring (1/4")
18	115-0025	3	Nut, Linkage Stud	40	850-0050	3	Washer, Lock - Spring (3/8")
19	150-0638	1	Joint, Ball	41	526-0030	3	Washer, Flat (13/32" ID x 7/8" OD x 1/8" THK)
20	801-0050	3	Screw, Cap - Hexhead (3/8-24 x 1")				
21	191-0732	1	Regulator, Alternator				
22	CABLE, SPARK PLUG						
	167-1525	1	Cylinder #1				
	167-1526	1	Cylinder #2				
	167-1527	1	Cylinder #3				
	167-1529	1	Cylinder #4				
	167-1530	1	Cylinder #5				
	167-1531	1	Cylinder #6				

* - For components contact your nearest Motorola dealer or Motorola Automotive Products, Inc., 9401 W. Grand Ave., Franklin Park, Illinois 60131.

** - Check Governor nameplate and order components from your nearest Hoof Products Company dealer.

AIR HEATER GROUP — OPTIONAL EQUIPMENT

REF. NO.	PART NO.	QTY. USED	PART DESCRIPTION
	133-0204	1	Heater Assembly, Carburetor Air (Includes Parts Marked *)
1	133-0201	1	*Duct, Carburetor Heater
2	133-0202	1	*Ring, Carburetor Heater
3	406-0105	3	*Fastener
4		1	*Hose, Flexible (Order 12" of Bulk Hose #503-0151)
5	133-0203	1	*Adapter, Carburetor Air Heater
6	505-0217	1	*Nipple (1/4 x 4-1/2")
7	812-0077	6	Screw, Tapping (Roundhead) - (#32 x 3/8")
8	850-0025	6	Washer, Lock (Spring) - #8
9		1	*Stripping, Weather (Order 24" of Bulk Stripping (895-0098))
10	140-0261	1	Cleaner, Air

* - Included in 133-0204 Carburetor Air Heater Assembly.

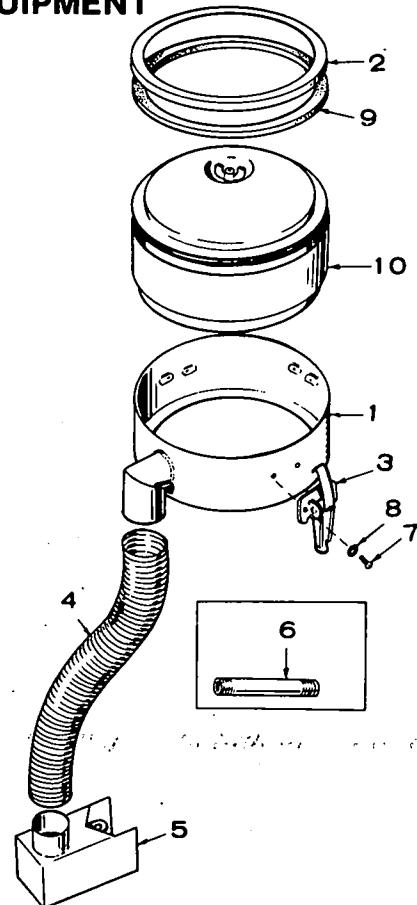

RESERVOIR (DAY) TANK GROUP — OPTIONAL EQUIPMENT

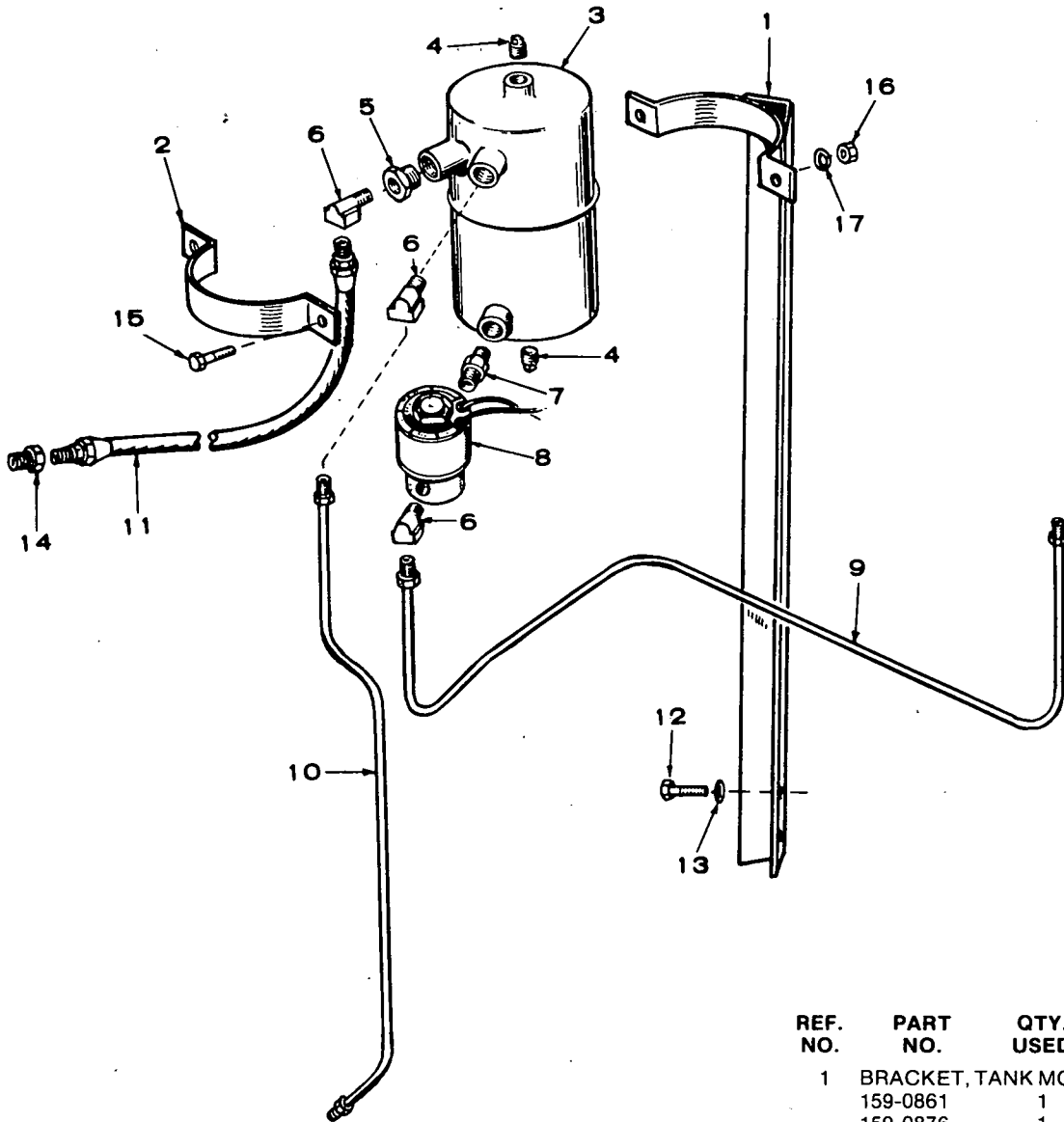

REF. NO.	PART NO.	QTY. USED	PART DESCRIPTION
1	BRACKET, TANK MOUNTING		
	159-0861	1	One Quart
	159-0876	1	Two Quart
2	CLAMP, TANK MOUNTING		
	159-0680	1	One Quart
	159-0875	1	Two Quart
3	TANK, RESERVOIR		
	159-0294	1	One Quart
	159-0746	1	Two Quart
4	505-0057	2	Plug
5	159-0705	1	Reducer, Restricted
6	502-0002	3	Elbow, Male
7	502-0082	1	Nipple, Solenoid Valve to Tank
8	307-0565	1	Valve, Solenoid (12 Volt)
9	159-0859	1	Line, Fuel - Tank to Carburetor
10	159-0860	1	Line, Fuel - Tank to Fuel Pump
11	501-0010	1	Line, Flexible Fuel
12	800-0071	2	Screw, Cap (Hexhead) - (7/16-14 x 1")
13	850-0055	2	Washer, Lock (Spring) - (7/16")
14	502-0003	1	Connector, Inverted Male
15	800-0005	2	Screw, Cap (Hexhead) - (1/4-20 x 3/4")
16	862-0001	2	Nut, Hex (1/4-20)
17	850-0040	2	Washer, Lock (Spring) - (1/4")

GASOLINE FUEL SYSTEM GROUP

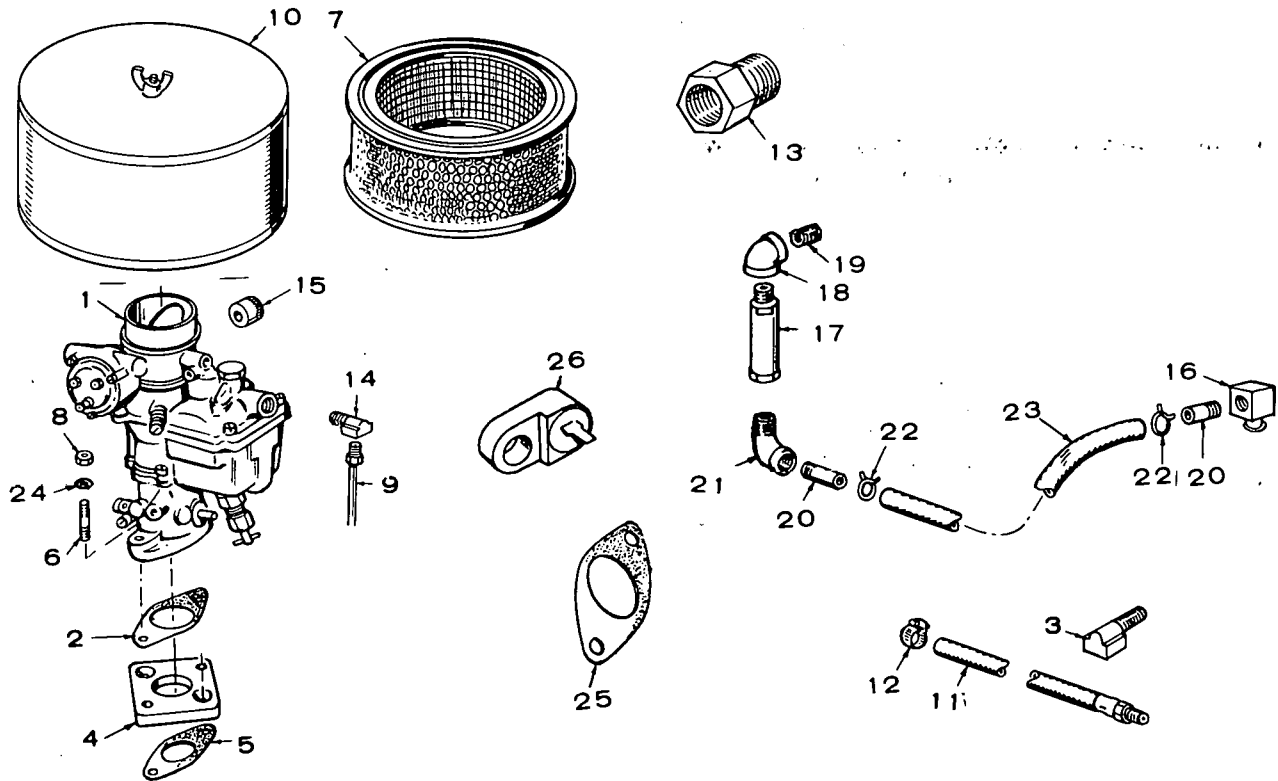

REF. NO.	PART NO.	QTY. USED	PART DESCRIPTION
1	*CARBURETOR (Zenith #28B10)		
	141-0575	1	Key 1 (Spec C through F)
	141-0627	1	Key 1 (Begin Spec G)
	141-0627	1	Key 2
2	145-0120	1	Gasket, Carburetor Mounting
3	502-0002	1	Elbow, Fuel Pump Outlet
4	148-0593	1	Adapter, Carburetor
5	154-0133	2	Gasket, Carburetor Adapter
6	520-0311	2	Stud, Carburetor Mounting
7	140-1089	1	Element, Air Cleaner
8	104-0091	2	Nut, Carburetor Mounting (3/8-24)
9	149-1052	1	Line, Fuel Pump to Carburetor
10	140-1083	1	Cleaner, Air (Includes Element)
11	501-0134	1	Line, Fuel to Pump
12	503-0373	1	Clamp, Fuel Line
13	502-0354	1	Adapter, Fuel Line
14	502-0002	1	Elbow, Carburetor Inlet
15	141-0372	1	Knob, Choke Shaft
16	123-1044	1	Adapter, Breather
17	123-0910	1	Valve, Breather
18	505-0038	1	Elbow, 90° (Breather)
19	505-0071	2	Nipple (Breather)
20	505-0302	2	Nipple, Half (Breather)
21	505-0011	1	Elbow, Street (Breather)
22	503-0614	2	Clamp, Hose (Breather)
23		1	Hose, Breather (Order 24" of Bulk Hose 503-0110)
24	854-0020	2	Washer, Lock (Internal Shakeproof) - Carburetor Mounting - (3/8")
25	145-0467	1	Plate, Carburetor Restrictor (EK Begin Spec G)
26	309-0269	1	Switch, Low Engine Temperature

For Components, contact your nearest Zenith Carburetor dealer or Zenith Carburetor Division, The Bendix Corporation, 696 Hart Avenue, Detroit, Michigan 48214

LIQUID PETROLEUM FUEL SYSTEM GROUP OPTIONAL EQUIPMENT

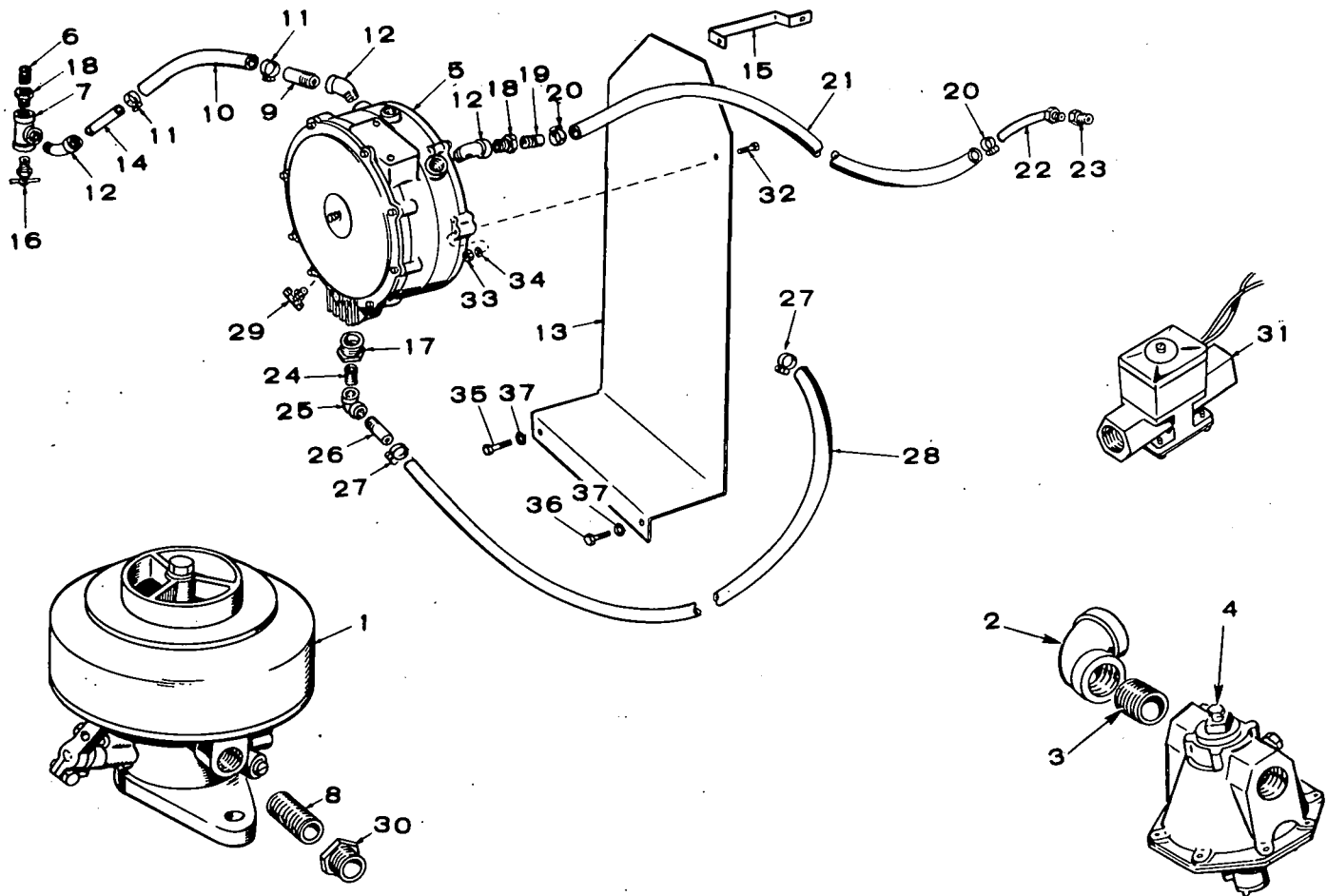

REF. NO.	PART NO.	QTY. USED	PART DESCRIPTION	REF. NO.	PART NO.	QTY. USED	PART DESCRIPTION
1	148-0643	1	*Carburetor (Impco #125-19)	21		1	Hose (12" of Bulk #503-0110)
2	505-0132	1	Elbow, Carburetor Inlet (3/4" x 90°)	22	130-0678	1	Line
3	505-0102	1	Nipple, Carburetor Inlet to Primary Regulator (3/4" x 1") - 2 used on LPG Vapor	23	502-0103	1	Connector
4	148-0637	1	Regulator, Gas - Primary - LPG Vapor Only	24	505-0102	1	Nipple, Pipe (3/4 x 1-3/8")
5	148-0625	1	Converter, LPG	25	505-0132	1	Elbow, Pipe (3/4 x 90°)
6	505-0099	1	Nipple (3/8 x 1")	26	505-0324	1	Nipple, Half (3/4 x 2")
7	505-0060	1	Tee (3/8")	27	503-0189	2	Clamp, Hose (1-3/16 to 1-1/2")
8	505-0100	1	Nipple (1/2 x 1-1/8")	28		1	Hose (29" of Bulk Hose #503-0249)
9	505-0135	1	Nipple, Half (3/8")	29	504-0005	1	Valve, Drain
10		1	Hose (11" of Bulk Hose #503-0386)	30	505-0021	1	Bushing, Reducer (3/4 x 1/2")
11	503-0183	2	Clamp, Hose (11/16 to 1-1/16")	31	307-0312	1	Valve, Solenoid
12	505-0119	3	Elbow, Street (3/8 x 45°)	32	800-0009	2	Screw, Cap (Hexhead) - (1/4-20 x 1-1/2")
13	148-0603	1	Bracket, Converter Mounting	33	862-0001	2	Nut, Hex (1/4-20")
14	505-0125	1	Nipple, Pipe (3/8 x 6")	34	850-0040	2	Washer, Lock (Spring) - (1/4")
15	148-0604	1	Brace, Converter Mounting Bracket	35	800-0069	1	Screw, Cap (Hexhead) - (7/16-14 x 3/4")
16	504-0028	1	Valve, Drain	36	800-0071	1	Screw, Cap (Hexhead) - (7/16-14 x 1")
17	505-0129	1	Bushing, Reducer (1 x 3/4")	37	850-0055	2	Washer, Lock (Spring) - (7/16")
18	505-0017	2	Bushing, Reducer (3/8 x 1/4")				
19	505-0010	1	Nipple, Half (1/4 x 1")				
20	503-0032	2	Clamp, Hose (7/8")				

* - For components contact your nearest Impco Dealer or Impco Division, 16916 Gridley Place, Cerritos, California, 90701

GAS AND GAS-GASOLINE FUEL SYSTEM GROUP OPTIONAL EQUIPMENT

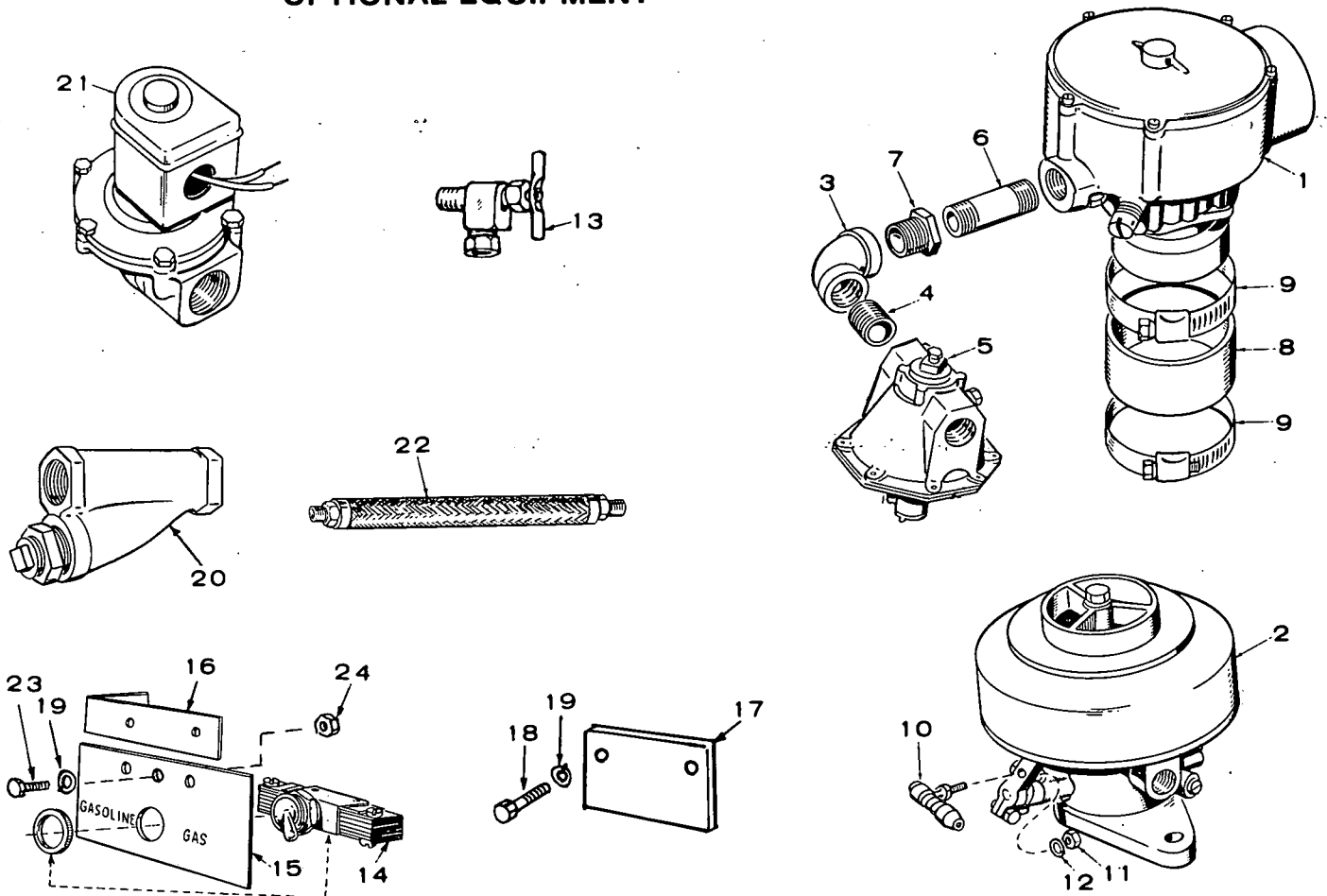

REF. NO.	PART NO.	QTY. USED	PART DESCRIPTION	REF. NO.	PART NO.	QTY. USED	PART DESCRIPTION
1	148-0691	1	*Carburetor (Mixer) - Gas-Gasoline Sets - (Impco #100M-4)	15	308-0150	1	Plate, Switch Mounting - Gas-Gasoline Sets
2	148-0643	1	*Carburetor (Mixer), Gas Only Sets - (Impco #125-29)	16	306-0155	1	Bracket, Switch Plate Mounting - Gas-Gasoline Sets
3	505-0132	1	Elbow, Gas Regulator - (3/4" x 90°)	17	149-0638	1	Cover, Fuel Pump Hole - Gas Only Sets
4	505-0102	1	Nipple, Gas Regulator (3/4 x 1-3/8")	18	800-0025	2	Screw, Cap (Hexhead) - (5/16-18 x 5/8")
5	148-0597	1	Regulator, Gas	19	850-0045	4	Washer, Lock (Spring) - 5/16" (2) Fuel Pump Hole Cover (2) Switch Mounting Plate
6	505-0100	1	Nipple (1/2 x 1-1/8")	20	149-0752	1	Strainer, Fuel (1") - Optional
7	505-0021	1	Bushing, Reducer - (3/4 x 1/1")	21	307-0836	1	Valve, Solenoid (1" - 12-Volt) - Optional
8	503-0542	1	Hose, Adapter - Gas-Gasoline Sets	22	503-0273	1	Line, Fuel (Flexible - 1" x 12") - Optional
9	503-0465	2	Clamp, Adapter Hose - Gas-Gasoline Sets	23	800-0026	2	Screw, Cap (Hexhead) - #18 x 3/4"
10	150-0638	1	Joint, Ball - Gas Only Sets	24	862-0015	2	Nut, Hex - (5/16-18)
11	115-0025	1	Nut, Hex (1/4-28)				
12	850-0040	1	Washer, Lock (Spring) - 1/4"				
13	504-0007	1	Valve, Fuel Pump Inlet - Gas-Gasoline Sets				
14	308-0005	1	Switch, Toggle - Gas-Gasoline Sets				

* - For components contact your nearest Impco Dealer or Impco Division, 16916 Gridley Place, Cerritos, California 90701

GENERATOR GROUP

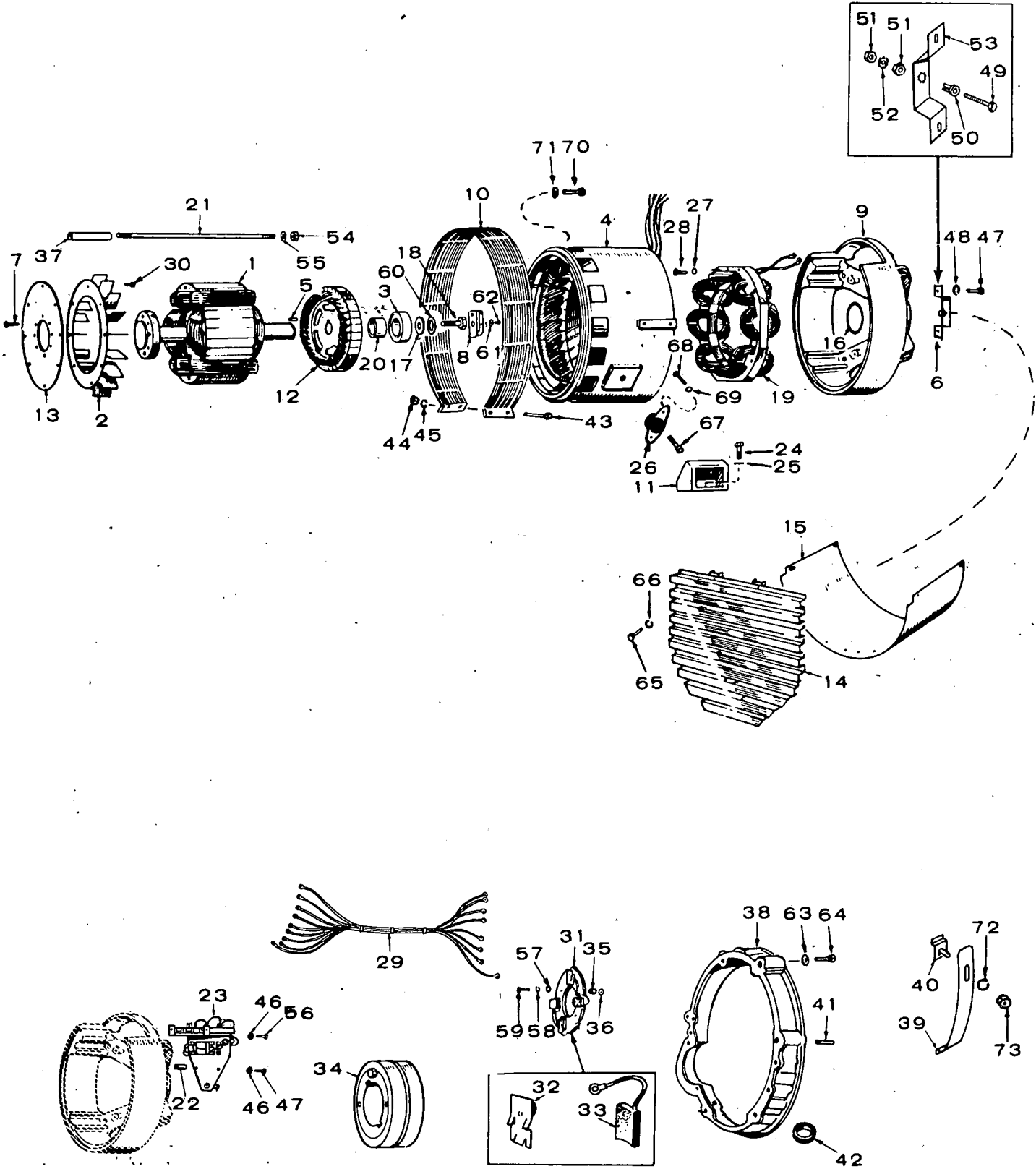

GENERATOR GROUP

REF. NO.	PART NO.	QTY. USED	PART DESCRIPTION	REF. NO.	PART NO.	QTY. USED	PART DESCRIPTION
1		1	Rotor Assembly, Wound (Includes Collector Ring on Early Brush Type Generators)	37	503-0611	4	Hose, Insulator
2	205-0089	1	Blower	38	231-0149	1	Adapter, Generator
3	510-0101	1	Bearing	39	232-2210	2	Cover, Adapter Slot
4		1	Stator Assembly, Wound	40	232-2211	2	Catch, Adapter Slot.Cover
5	515-0145	1	Key, Exciter Rotor - Brushless Generator	41	516-0152	2	Pin, Generator Adapter Alignment
6	150-1456	1	Bracket and Contact Assembly - Begin Spec F (Includes Parts Marked †)	42	508-0001	1	Grommet, Rubber - Generator Adapter
7	805-0033	8	Bolt, Place (5/8-11 x 1")	43	800-0008	2	Screw, Cap - Hex Head (1/4-20 x 1-1/4")
8	150-0717	1	Switch Assembly, Overspeed	44	862-0001	2	Nut, Hex (1/4-20)
9	211-0185	1	Bell, End	45	850-0040	2	Washer, Lock - Spring (1/4")
10	234-0368	1	Screen, Generator	46	853-0013	4	Washer, Lock - ET (1/4") - Spec B through F
11	232-2106	2	Bracket, Generator Mounting	47	800-0003	2	Screw, Cap - Hex Head (1/4-20 x 1/2")
12	201-1739	1	Rotor Assembly, Wound - Exciter (See Separate Group for Components) - Brushless Generator	48	850-0040	2	Washer, Lock - Spring (1/4")
13	232-2078	1	Disc, Generator Drive	49	150-0723	1	†Point, Overspeed Switch
14	234-0370	1	Grille, Generator Air Inlet	50	870-0250	1	†Nut, Insulation - Overspeed Switch
15	234-0361	1	Wrapper, Generator End Bell	51	862-0001	2	†Nut, Hex (1/4-20)
16	509-0125	1	Seal, "O" Ring - Bearing	52	853-0013	1	†Washer, Lock - ET (1/4")
17	526-0238	1	Washer, Bearing Retainer	53	150-1356	1	†Bracket, Overspeed Switch
18	800-0513	1	Screw, Cap - Hex Head (3/4-10 x 1-1/2")	54	862-0011	4	Nut, Hex - Machine (3/8-16)
19	220-2353	1	Stator Assembly, Wound - Exciter - Brushless Generator	55	850-0050	4	Washer, Lock - Spring (3/8")
20	232-2102	1	Spacer, Bearing - Brushless Generator	56	800-0009	2	Screw, Cap - Hex Head (1/4-20 x 1-1/2") - Spec B through F
21	STUD, GENERATOR THROUGH			57	526-0018	4	Washer, Flat (17/64" I.D. x 5/8" O.D. x 1/16" Thick) - Brush Type Generators
	520-0721	4	1 Phase Generator	58	850-0040	4	Washer, Lock - Spring (1/4") - Brush Type Generator
	520-0718	4	3 Phase Generator	59	114-0023	4	Screw, Cap - Hex Head (1/4-20 x 1-1/4") - Brush Type Generator
22	305-0481	1	Spacer, Voltage Regulator Chassis Mounting	60	850-0079	1	Washer, Lock - Spring (3/4")
23	CHASSIS ASSEMBLY, VOLTAGE REGULATOR (See Separate Group For Components) - SPEC A THROUGH E			61	856-0010	1	Washer, Lock EIT (3/8")
	305-0489	1	Brush Type Generator	62	812-0189	1	Screw, Machine - Round Head (3/8-16 x 3/4")
	305-0491	1	Brushless Generator	63	850-0055	9	Washer, Lock - Spring (7/16")
24	800-0091	4	Screw, Cap - Hex Head (1/2-13 x 1-1/4")	64	800-0072	9	Screw, Cap - Hex Head (7/16-14 x 1-1/4")
25	850-0060	4	Washer, Lock - Spring (1/2")	65	812-0146	4	Screw, Machine - Round Head (1/4-20 x 3/8")
26	402-0030	2	Mount, Vibration - Generator End	66	850-0040	4	Washer, Lock - Spring (1/4")
27	850-0040	4	Washer, Lock - Spring (1/4")	67	800-0520	2	Screw, Cap - Hex Head (3/4-10 x 1")
28	800-0009	4	Screw, Cap - Hex Head (1/4-20 x 1-1/2")	68	800-0071	4	Screw, Cap - Hex Head (7/16-14 x 1")
29	338-0521	1	Harness Assembly, Voltage Regulator	69	850-0055	4	Washer, Lock - Spring (7/16")
30	805-0018	8	Bolt, Place (3/8-16 x 1")	70	800-0051	8	Screw, Cap - Hex Head (3/8-16 x 1-1/4")
31	212-0342	1	Rig Assembly, Brush - Includes Brushes and Springs Brush Type Generators	71	850-0050	8	Washer, Lock - Spring (3/8")
32	212-1105	4	Spring, Brush Brush Type Generator	72	850-0040	2	Washer, Lock - Spring (1/4")
33	214-0046	4	Brush Brush Type Generator	73	862-0001	2	Nut, Hex (1/4-20)
34	204-0083	1	Ring, Collector Brush Type Generator				
35	212-1225	4	Spacer, Brush Rig Mounting - Early Brush Type Generators				
36	526-0018	4	Washer, Brush Rig Mounting - Early Brush Type Generators				

* - Order by description giving complete Model, Spec and Serial Number.

† - Included in 150-1456 Bracket and Contact Assembly.

VOLTAGE REGULATOR GROUP

- SPEC A THROUGH E

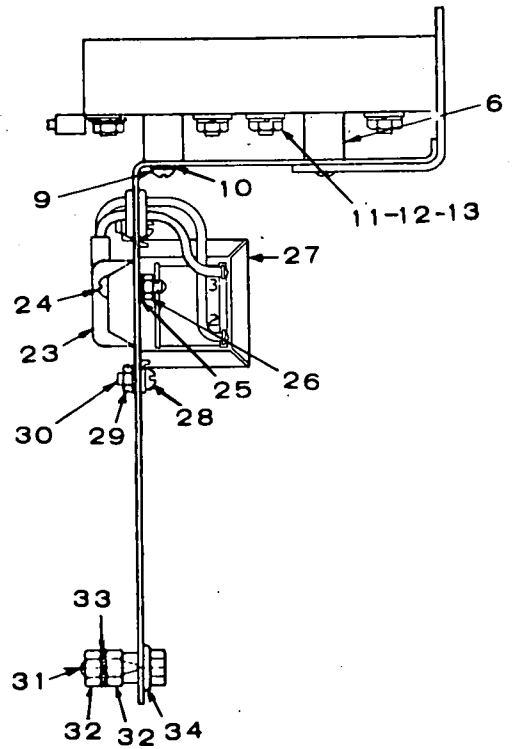
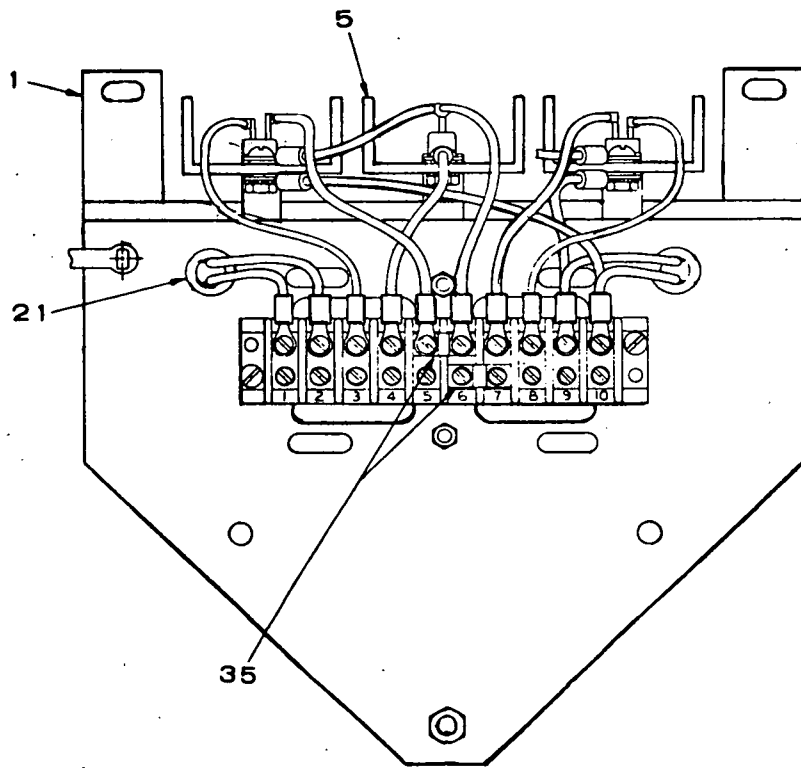
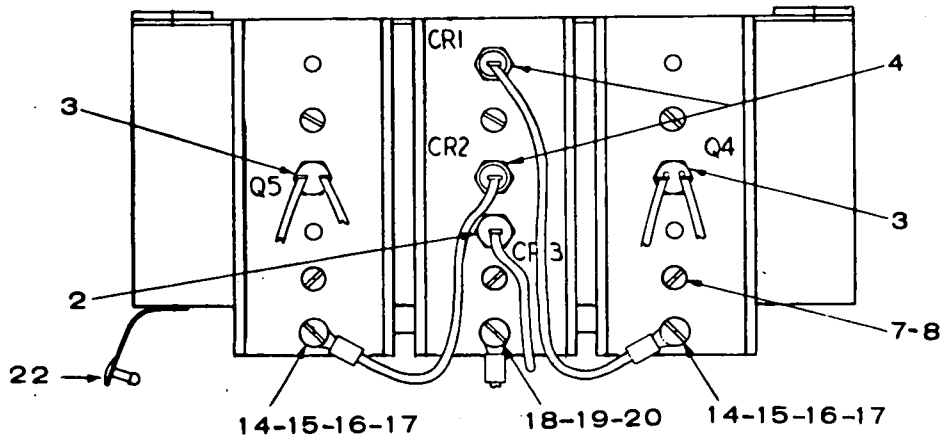

VOLTAGE REGULATOR GROUP - SPEC A THROUGH E

REF. NO.	PART NO.	QTY. USED	PART DESCRIPTION	REF. NO.	PART NO.	QTY. USED	PART DESCRIPTION
CHASSIS ASSEMBLY, VOLTAGE REGULATOR (Complete) 305-0491				17	871-0007	2	*†Nut, Hex - Rectifier Lead to Heat Sink (#8-32)
	305-0489	1	Brushless Generator (Includes Parts Marked *)	18	812-0079	1	*†Screw, Machine Roundhead - Terminal Block Lead to Heatsink (#8-32 x 1/2")
1	305-0482	1	*†Chassis, Voltage Regulator	19	853-0005	1	*†Washer, Lock - ET - Terminal Block to Heat Sink (#8)
2	358-0029	1	*†Rectifier, Silicon (CR3)	20	871-0007	1	*†Nut, Hex - Terminal Block Lead to Heat Sink (#8-32)
3	RECTIFIER, SILICON CONTROLLED			21	508-0002	2	*†Grommet, Rubber
	364-0014	2	*Brushless Generator (Q4 & Q5)	22	332-1415	1	*†Clamp, Cable
	364-0012	2	†Brush Type Generator (Q4 & Q5)	23	332-1266	1	*†Block, Terminal
4	RECTIFIER, SILICON			24	812-0081	2	*†Screw Machine - Roundhead - Terminal Block Mounting (#8-32 x 5/8")
	358-0035	2	*Brushless Generator (CR1 & CR2)	25	853-0005	2	*†Washer, Lock - ET - Terminal Block Mounting (#8)
	358-0031	2	†Brush Type Generator (CR1 & CR2)	26	860-0008	2	*†Nut, Hex - Terminal Block Mounting (#8-32)
5	363-0048	3	*†Heat Sink, Rectifier	27	REACTOR ASSEMBLY, COMMUTATOR		
6	332-1265	6	*†Insulator, Stand off	315-0343	1	*Brushless Generator	
7	812-0077	6	*†Screw, Roundhead - Heat Sink Mtg. (8-32 x 3/8")	315-0341	1	†Brush Type Generator	
8	853-0005	6	*†Washer, Lock - ET - Heat Sink Mtg. (#8)	28	812-0077	2	*†Screw, Machine - Roundhead - Reactor Mtg. (#8-32 x 3/8")
9	812-0077	6	*†Screw, Machine Roundhead - Stand off Insulator Mtg. (#8-32 x 3/8")	29	853-0005	2	*†Washer, Lock - ET - Reactor Mounting (#8)
10	853-0005	6	*†Washer, Lock - ET Stand off Insulator Mtg. (#8)	30	860-0008	2	*†Nut, Hex - Reactor Mtg. (#8-32)
11	871-0010	3	*†Nut, Hex - Rectifier Mounting (CR1, CR2 & CR3) (#10-32)	31	150-0723	1	*†Point, Contact - Overspeed Switch
12	526-0009	3	*†Washer, Flat (7/32" I.D. x 1/2" O.D. x 1/16" Thick) - Rectifier Mtg. (CR1, CR2 & CR3)	32	862-0001	2	*†Nut, Hex - Contact Point (1/4-20)
13	850-0030	3	*†Washer, Lock - Spring - Rectifier Mtg. (CR1, CR2 & CR3) (#10)	33	853-0013	1	*†Washer, Lock - ET Contact Point (1/4)
14	812-0079	2	*†Screw, Machine - Roundhead - Rectifier Lead to Heat Sink (#8-32 x 1/2")	34	870-0250	2	*†Nut, Insulator - Contact Point (1/4)
15	526-0048	2	*†Washer, Flat (Brass) (.172" I.D. x 3/8" O.D. x 1/32" Thick)	35	332-1043	2	*†Jumper - Terminal Block
16	853-0005	2	*†Washer, Lock - ET - Rectifier Lead to Heat Sink (#8)	* - Parts included in 305-0491 Voltage Regulator. † - Parts included in 305-0489 Voltage Regulator.			

MOUNTING AND HOUSING GROUP

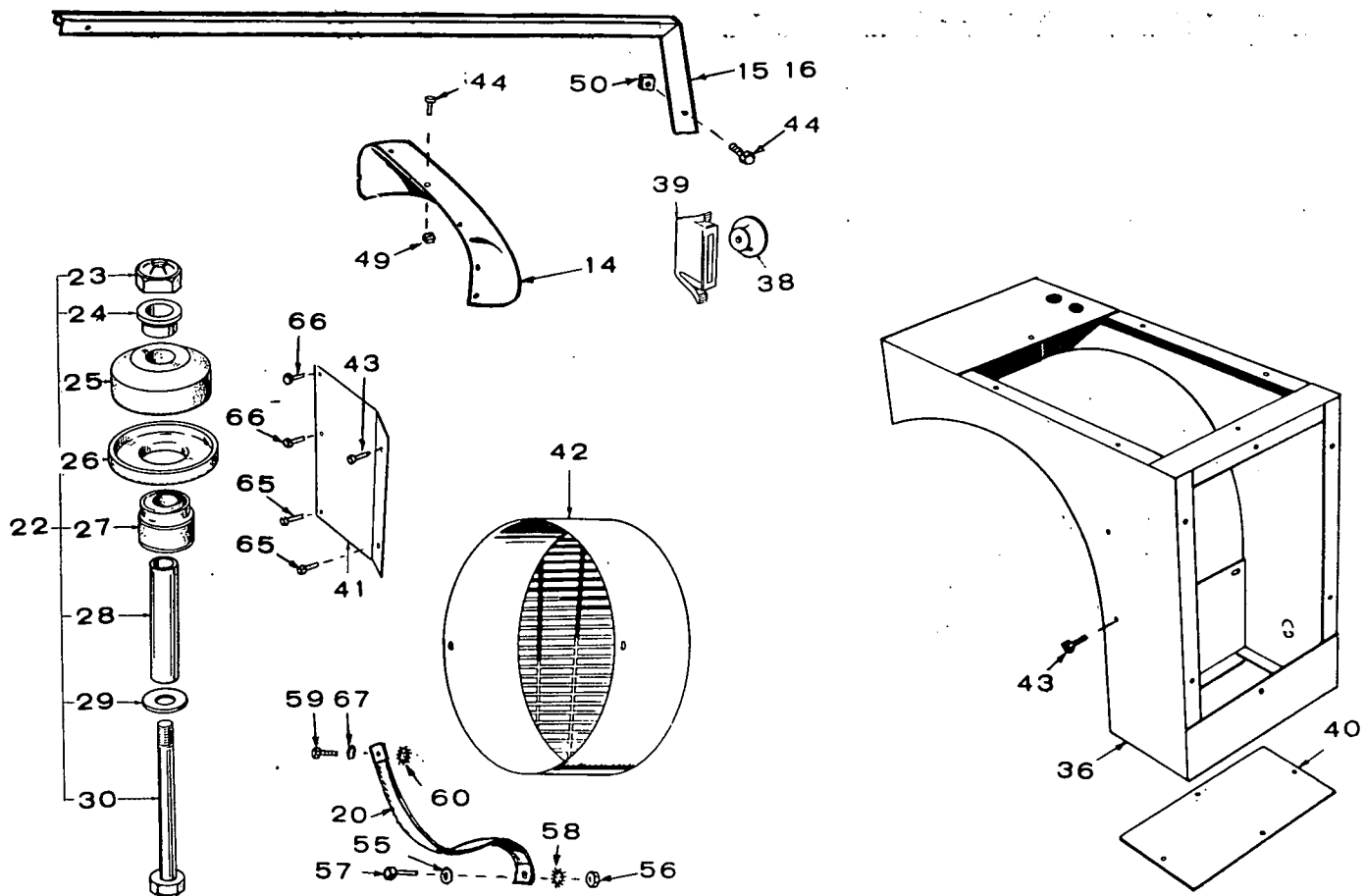
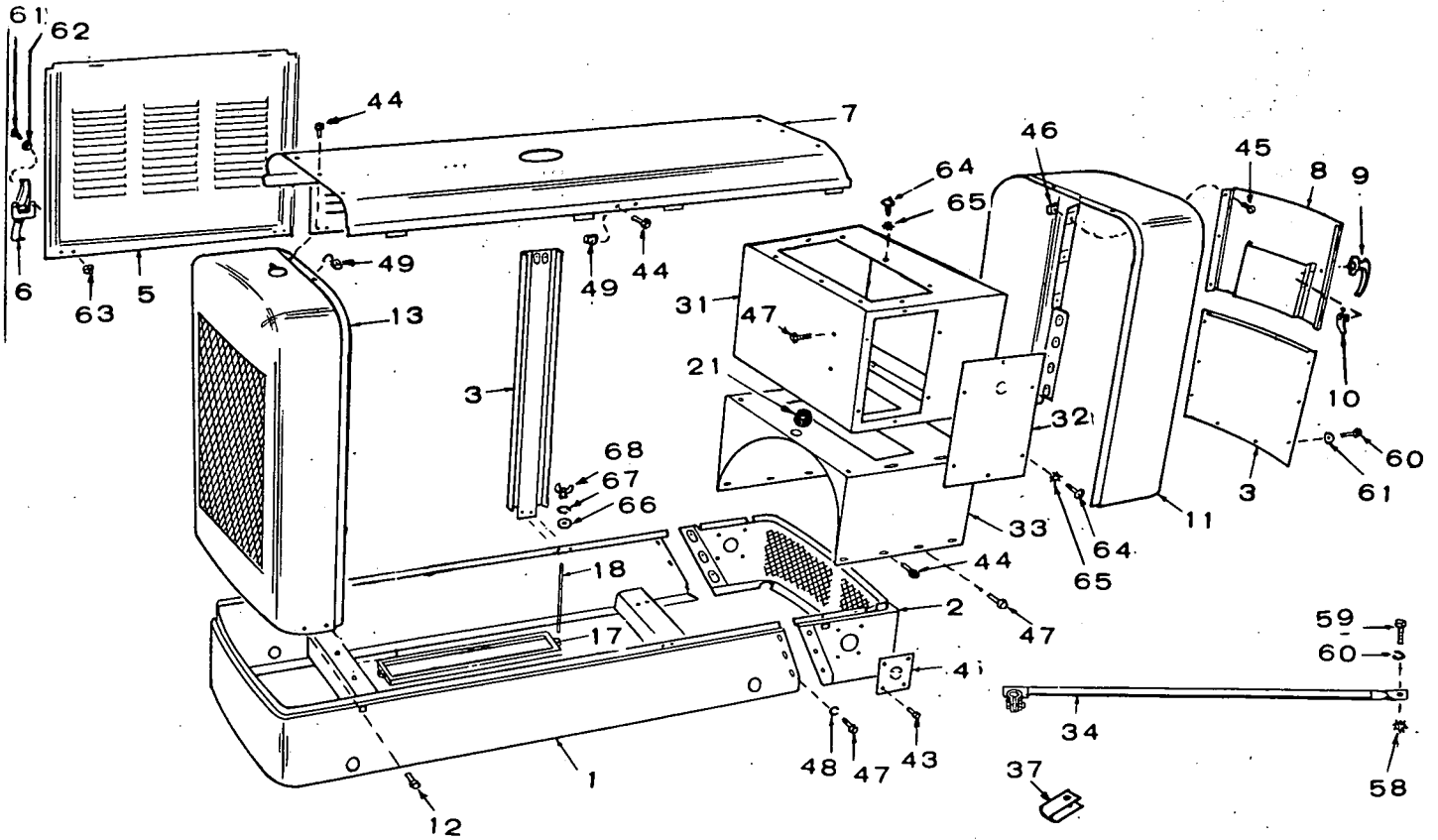

MOUNTING AND HOUSING GROUP

REF. NO.	PART NO.	QTY. USED	PART DESCRIPTION	REF. NO.	PART NO.	QTY. USED	PART DESCRIPTION
1	403-0902	1	Chassis, Front	35	416-0667	1	Tray, Battery
2	403-0894	1	Chassis, Rear - Housed Sets	36	301-3191	1	Junction Box, Output - Housed Sets
3	405-1780	1	Panel, Rear Housing Access - Housed Sets	37	416-0096	4	Clamp, Battery Cable
4	403-0895	2	Cover, Conduit Opening - Housed Sets	38	406-0002	1	Knob, Door - Housed Sets (Used on Some Early Models)
5	405-1808	4	Panel, Side Door - Housed Sets	39	406-0335	2	Catch, Door - Housed Sets (Used on Some Early Models)
6	406-0105	8	Clamp, Door - Housed Sets	40	301-3195	1	Plate, Junction Box Bottom - Housed Sets
7	405-1809	1	Panel, Top - Housed Sets	41	301-3196	1	Bracket, Junction Box - Housed Sets
8	405-1777	1	Panel, Rear Door - Housed Sets	42	234-0369	1	Cover, End Bell - Housed Sets
9	406-0157	1	Handle, Door (Includes Keys) - Housed Sets	43	821-0010	As Req.	Screw, Cap (Self Locking) - 1/4-20 x 1/2"
10	406-0089	1	Catch, Door - Housed Sets	44	821-0016	4	Screw, Cap (Self Locking) - 5/16-18 x 3/4" - Housed Sets
11	405-1812	1	Panel, Rear - Housed Sets	45	809-0059	3	Screw, Tapping (Pan Head) - #14 x 1/2" - Housed Sets
12	821-0014	As Req.	Screw, Cap (Locking Head) - (5/16-18 x 1/2")	46	870-0106	3	Nut, Speed - #14
13	405-1811	1	Panel, Front - Radiator Cooled Sets	47	800-0048	6	Screw, Cap (Hexhead) - 3/8-16 x 3/4" - Housed Sets
14	405-1409	1	Extension, Radiator Hood - Unhoused Radiator Cooled Sets	48	850-0050	6	Washer, Lock (Spring) - 3/8" - Housed Sets
15	403-0903	1	Trim, Right Hand Chassis - Unhoused Sets	49	870-0113	As Req.	Nut, Retainer - (5/16-18)
16	403-0904	1	Trim, Left Hand Chassis - Unhoused Sets	50	870-0020	6	Nut, Weld - (5/16-18)
17	416-0612	1	Frame, Battery Hold-down	51	800-0003	4	Screw, Cap (Hexhead) - 1/4-20 x 1/2"
18	520-0663	2	Stud, Battery Hold-down	52	526-0018	8	Washer, Flat (17/64" ID x 5/8" OD x 1/16" THK)
19	405-1814	2	Support, Housing Center - Housed Sets	53	850-0040	4	Washer, Lock (Spring) - 1/4"
20	337-0090	1	Strap, Ground	54	862-0001	4	Nut, Hex (1/4-20)
21	508-0001	1	Grommet, Rubber - Control Box Housing (2 used on Housed Sets)	55	850-0060	3	Washer, Lock (Spring) - 1/2"
22	402-0338	1	Mounting Assembly, Engine End - (Includes Parts Marked *)	56	862-0016	3	Nut, Hex - (1/2-13)
23	870-0068	1	*Nut, Huglock (7/16-20)	57	800-0091	1	Screw, Cap (Hexhead) - Ground Strap (1/2-13 x 1-1/4")
24	402-0337	1	*Spacer, Engine Mount	58	856-0013	1	Washer, Lock (External/Internal) - 1/2"
25	402-0010	1	*Mount, Rubber (Front)	59	800-0071	1	Screw, Cap (Hexhead) - Ground Strap (7/16-14 x 1")
26	402-0012	1	*Cup, Metal	60	856-0012	1	Washer, Lock (External/Internal) - 7/16" Ground Strap
27	402-0011	1	*Mount, Rubber (Lower)	61	813-0098	22	Screw, Machine (Roundhead) - (10-32 x 3/8")
28	403-0633	1	*Spacer, Mount	62	850-0030	22	Washer, Lock (Spring) - #10 - Housed Sets
29	526-0141	1	*Washer, Flat (15/32" ID x 1-1/4" OD x 1/8" THK)	63	870-0053	16	Nut, Hex (10-32) - Housed Sets
30	801-0080	1	*Screw, Cap (Hexhead) - (7/16-20 x 3-1/2" lg)	64	815-0026	18	Screw, Machine (Trusshead) - (10-32 x 3/8")
31	301-3155	1	Housing, Control Box - Unhoused Sets	65	853-0018	18	Washer, Lock (External) - #10
32	PANEL, CONTROL BOX HOUSING			66	526-0115	2	Washer, Flat (11/32" ID x 11/16" OD x 1/16" THK)
	301-3156	3	Unhoused Sets	67	850-0045	2	Washer, Lock (Spring) - 5/16"
	301-3156	2	Housed Sets - (Also Unhoused Sets With Circuit Breaker)	68	865-0007	2	Nut, Wing - Battery Hold-down (5/16-18)
	301-3156	1	Housed Sets With Circuit Breaker				
33	301-3154	1	Saddle, Control Box Housing - Unhoused Sets				
34	CABLE, BATTERY						
	416-0049	1	14-1/2" long				
	416-0613	1	10" long				

* - Parts Included in 402-0338 Engine Mounting Assembly.

CONTROL GROUP (ENGINE INSTRUMENTS PORTION)

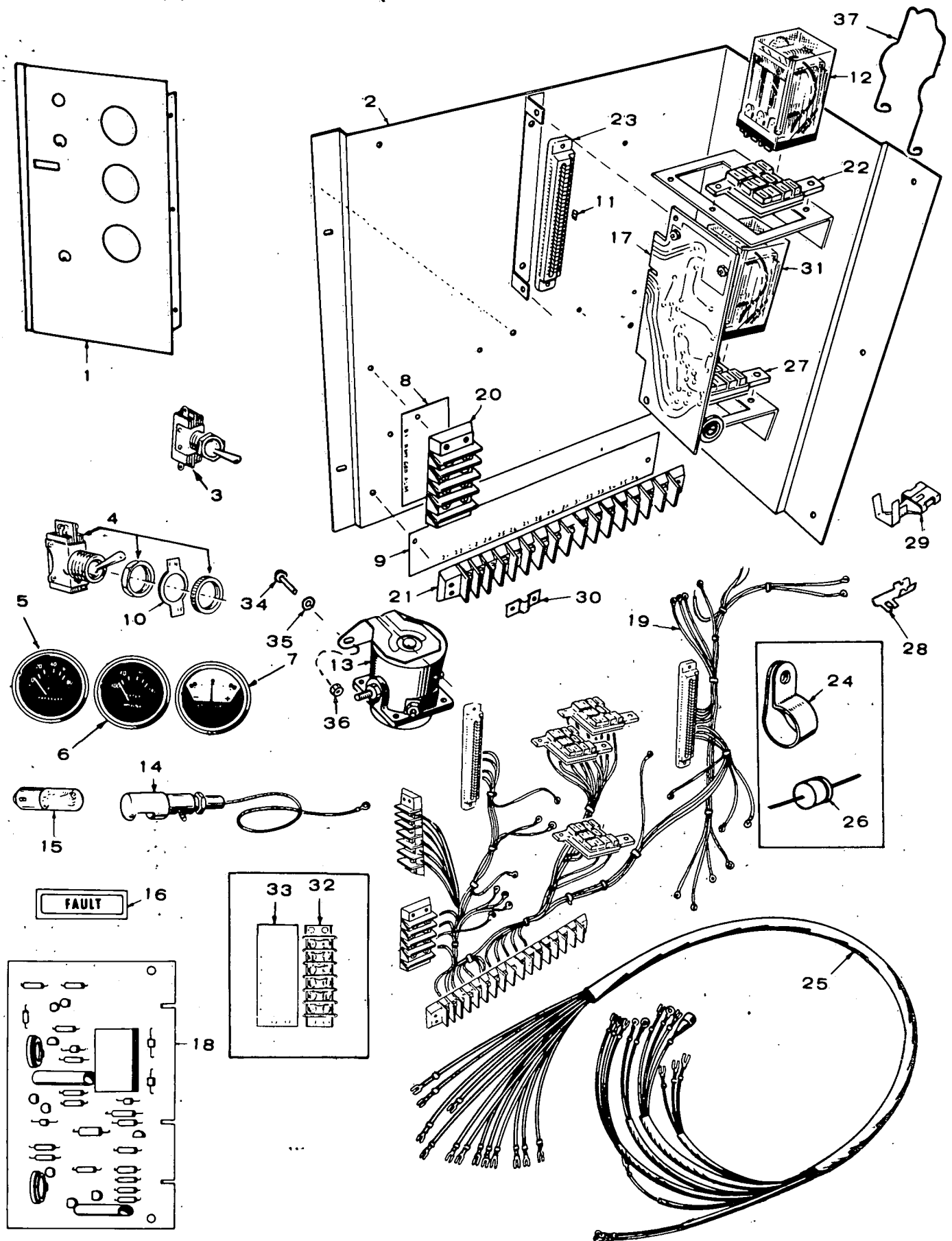

CONTROL GROUP (ENGINE INSTRUMENT PORTION)

REF. NO.	PART NO.	QTY. USED	PART DESCRIPTION	REF. NO.	PART NO.	QTY. USED	PART DESCRIPTION
1	PANEL ONLY, ENGINE CONTROL			18	MONITOR, ENGINE CONTROL (See Separate Group for Components)		
	301-3165	1	Sets With One Fault Light		300-0679	1	Sets With One Fault Light - Standard
	301-3267	1	Sets With Five Fault Lights - Optional		300-0681	1	Sets With Five Fault Lights - Optional.
2	301-3253	1	Bracket, Engine Control	19	HARNESSE ASSEMBLY, WIRING - CONTROL (Includes Parts Marked *)		
3	308-0138	1	Switch, Selector		338-0527	1	Sets With One Fault Light - Standard
4	308-0002	1	Switch, Panel Light		338-0535	1	Sets With Five Fault Lights - Optional
5	193-0107	1	Gauge, Oil Pressure	20	332-0537	1	*Block, Terminal - 4 Place
6	193-0106	1	Gauge, Water Temperature	21	332-0795	1	*Block, Terminal - 16 Place
7	302-0061	1	Ammeter, Charge (30-0-30)	22	323-0765	2	*Socket, Relay - 11 Place
8	332-1239	1	Strip, Marker (B+, Remote, Ground Alarm)	23	332-1271	2	*Housing, Printed Circuit Board Terminal
9	332-1241	1	Strip, Marker (21 through 36)	24	332-0051	1	Clip, Tinnerman
10	308-0003	1	Plate, Switch (On-Off)	25	338-0533	1	Harness Assembly, Wiring - Engine to Control
11	332-1276	2	Plug, Keying (Sets With Five Fault Lights Use Quantity of 1)	26	357-0004	1	Rectifier, Diode (Part of Standard Cranker Control)
12	307-1058	2	Relay (1) Start-Disconnect, (1) Ignition	27	323-0764	1	*Socket, Relay - 8 Place
13	307-1031	1	Relay, Start Solenoid (Mounted in Chassis)	28	332-1269	As Req.	*Terminal, PC Board
14	322-0073	1	Holder, Lamp	29	332-1280	As Req.	*Terminal, Crimp
15	322-0074	1	Lamp, Panel	30	332-1043	1	*Jumper, Terminal - Sets With One Fault Light
16	LAMP, FAULT			31	307-1061	1	Relay, Starter Protection - Begin Spec D
	322-0128	1	Standard Sets	32	332-0699	1	*Block, Terminal (6 Place) - Sets With Five Fault Lights
	322-0107	1	Overcrank (Optional)	33	332-1240	1	*Strip, Marker (53 through 58) - Sets With Five Fault Lights
	322-0111	1	Overspeed (Optional)	34	312-0148	2	Screw, Cap (Roundhead) - (1/4-20 x 1/2")
	322-0108	1	Low Oil Pressure (Optional)	35	850-0040	2	Washer, Lock (Spring) - (1/4")
	322-0109	1	High Engine Temperature (Optional)	36	862-0001	2	Nut, Hex - (1/4-20)
	322-0110	1	Low Engine Temperature (Optional)	37	307-1157	3	Spring, Relay Hold-down
17	CONTROL, CRANKER						
	300-0733	1	Standard Cranker				
	300-0714	1	Cycle Cranker (Optional) - See Separate Group for Components				

* - Included in Wiring Harness Assembly.

CONTROL GROUP (AC OUTPUT PORTION)

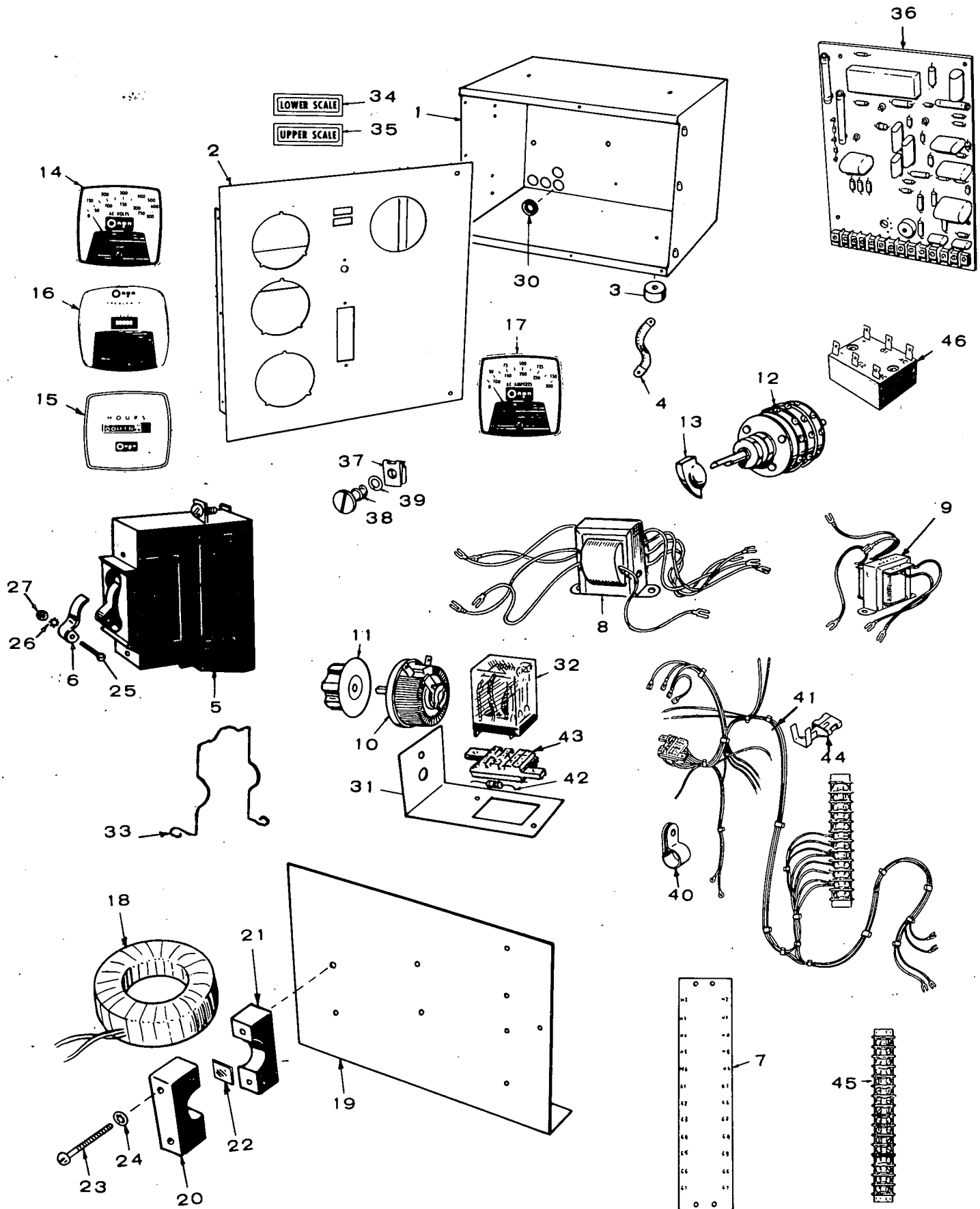

CONTROL GROUP (AC OUTPUT PORTION)

REF. NO.	PART NO.	QTY. USED	PART DESCRIPTION	REF. NO.	PART NO.	QTY. USED	PART DESCRIPTION
1	301-3158	1	Box Only, Control	18	TRANSFORMER, CURRENT		
2	PANEL ONLY, CONTROL				302-0209	2	25.0EK-53R, 30.0EK-3R, 37.5EM-53R & 45.0EM-3R Sets
	301-3167	1	Sets Without Meter Panel 25.0EK-53R, 30.0EK-3R, 37.5EM-53R & 45.0EM-3R Sets		302-0079	3	25.0EK-515R, 30.0EK-15R & 37.5EM-515R Sets
	301-3168	1	25.0EK-515R, 30.0EK-15R, 37.5EM-515R & 45.0EM-15R Sets		302-0106	3	45.0EM-15R Sets
	301-3341	1	30.0EK-9XR & 45.0EM-9XR Sets		302-0117	3	30.0EK-9XR Sets
	301-3169	1	Sets With Meter Panel 25.0EK-53R, 30.0EK-3R, 37.5EM-53R & 45.0EM-3R Sets		302-0076	3	45.0EM-9XR Sets
	301-3170	1	25.0EK-515R, 30.0EK-15R, 37.5EM-515R & 45.0EM-15R Sets	19	302-0729	1	Bracket, Transformer Mounting
	301-3342	1	30.0EK-9XR & 45.0EM-9XR Sets	20	CLAMP, TRANSFORMER MOUNTING - UPPER		
3	402-0078	4	Rubber, Mounting - Control Box		302-0235	2	25.0EK-53R, 30.0EK-3R, 37.5EM-53R & 45.0EM-3R Sets
4	337-0049	1	Strap, Ground		302-0235	3	25.0EK-515R, 30.0EK-15R, 37.5EM-515R, 45.0EM-15R, 30.0EK-9XR & 45.0EM-9XR Sets
5	BREAKER, CIRCUIT			21	CLAMP, TRANSFORMER MOUNTING - LOWER		
	320-0002	1	Brush Type Generator Key 1		302-0236	2	25.0EK-53R, 30.0EK-3R, 37.5EM-53R & 45.0EM-3R Sets
	320-0018	1	Key 2		302-0236	3	25.0EK-515R, 30.0EK-3R, 37.5EM-515R, 45.0EM-15R, 30.0EK-9XR & 45.0EM-9XR Sets
	320-0431	1	Brushless Generator	22	SHIM, TRANSFORMER MOUNTING		
6	320-0307	1	Lock, Circuit Breaker Handle (Penn State)		302-0253	2	25.0EK-53R, 30.0EK-3R, 37.5EM-53R & 45.0EM-3R Sets
7	STRIP, MARKER				302-0253	3	25.0EK-515R, 30.0EK-15R, 37.5EM-515R, 45.0EM-15R, 30.0EK-9XR & 45.0EK-9XR Sets
	332-1248	1	Sets Without Meter Panel	23	813-0110	6	Screw, Roundhead Machine - Transformer Mounting (10-32 x 2")
	332-1242	1	Sets With Meter Panel	24	854-0010	6	Washer, Internal Lock - Transformer Mounting (#10)
8	315-0342	1	Transformer, Voltage	25	815-0203	1	Screw, Roundhead (10-32 x 7/8")
9	REACTOR, COMMUTATOR (Begin Spec F)			26	854-0010	2	Washer, Internal Lock (#10)
	315-0384	1	With Leads and Terminals	27	871-0010	3	Nut, Hex (10-32)
	315-0343	1	Without Leads and Terminals	28	526-0049	2	Washer, Flat
10	303-0170	1	Rheostat	29	856-0003	1	Washer, External/Internal Lock
11	303-0032	1	Knob, Rheostat	30	508-0001	4	Grommet, Rubber
12	SWITCH, SELECTOR			31	301-3244	1	Bracket, Relay Mounting - 25.0EK-515R, 30.0EK-15R, 37.5EM-515R & 45.0EM-15R Sets
	308-0012	1	Sets Without Meter Panel	32	307-1061	1	Relay, Voltage Selector - 25.0EK-515R, 30.0EK-15R, 37.5EM-515R & 45.0EM-15R Sets
	308-0284	1	Sets With Meter Panel	33	307-1157	1	Spring, Relay Hold-down
13	303-0076	1	Knob, Selector Switch	34	322-0130	1	Light, Lower Scale - 25.0EK-515R, 30.0EK-15R, 37.5EM-515R & 45.0EM-15R Sets
14	VOLTMETER			35	322-0131	1	Light, Upper Scale - 25.0EK-515R, 30.0EK-15R, 37.5EM-515R & 45.0EM-15R Sets
	302-0421	1	25.0EK-53R, 30.0EK-3R, 37.5EM-3R and 45.0EM-3R Sets	36	BOARD ASSEMBLY, PRINTED CIRCUIT (See Separate Group for Components)		
	302-0718	1	25.0EK-515R, 30.0EK-15R, 37.5EM-515R & 45.0EM-15R Sets		332-1264	1	Brush Type Generator
	302-0779	1	30.0EK-9XR & 45.0EM-9XR Sets		332-1268	1	Brushless Generator
15	METER, RUNNING TIME			37	406-0332	2	Fastener
	302-0469	1	Sets With Meter Panel 50 Hertz Sets				
	302-0466	1	60 Hertz Sets				
16	METER, FREQUENCY						
	302-0256	1	Sets With Meter Panel 50 Hertz Sets				
	302-0221	1	60 Hertz Sets				
17	AMMETER, AC (Sets With Meter Panel)						
	302-0412	2	25.0EK-53R, 30.0EK-3R, 37.5EM-53R & 45.0EM-3R Sets				
	302-0719	1	25.0EK-515R, 30.0EK-15R & 37.5EM-515R Sets				
	302-0720	1	45.0EM-15R Sets				
	302-0405	1	30.0EK-9XR Sets				
	302-0406	1	45.0EM-9XR Sets				

NOTE: The 332-1264 Printed Circuit Board Assembly is no longer available—order 332-1268 Printed Circuit Board Assembly.

CONTROL GROUP (AC OUTPUT PORTION)

REF. NO.	PART NO.	QTY. USED	PART DESCRIPTION
38	406-0333	2	Stud, Fastener
39	406-0334	2	Washer, Stud Fastener
40	332-0050	2	Clip, Tinnerman
41	HARNES, WIRING - AC CONTROL (Includes Parts Marked *)		SETS WITHOUT METER PANEL
	338-0765	1	30.0EK-3R & 45.0EM-3R
	338-0764	1	25.0EK-515R, 30.0EK-15R, 37.5EM-515R & 45.0EM-15R
	338-0766	1	30.0EK-9XR & 45.0EM-9XR
	SETS WITH METER PANEL		
	338-0735	1	30.0EK-3R & 45.0EM-3R
	338-0730	1	25.0EK-515R, 30.0EK-15R, 37.5EM-515R, 45.0EM-15R
	339-0759	1	30.0EK-9XR & 45.0EM-9XR
42	350-0556	1	Resistor (47,000-Ohm, 1/2 Watt)
43	323-0764	1	Socket, Relay
44	332-1280	As Req.	Terminal, Crimp
45	BLOCK, TERMINAL		
	332-0607	1	Sets Without Meter Panel (12 Place)
	332-0795	1	Sets With Meter Panel (16 Place)
46	305-0524	1	Bridge, Rectifier (Begin Spec F)

CRANKER CYCLE CONTROL GROUP - 12 VOLT (Optional Equipment)

REF. NO.	PART NO.	QTY. USED	PART DESCRIPTION
	300-0714		Control, Cranker Cycle - 12 Volt
C1	356-0039	1	Capacitor, Electrolytic (100 Mfd, 10 Volt)
C2	355-0010	1	Capacitor, Plastic Dielectric (.0022 Mfd, 100 VDC, 10%)
CR1	359-0027	1	Diode, Zener
CR2	357-0004	1	Diode, Rectifier (400 MA, 400 Volt)
CR3	357-0004	1	Diode, Rectifier (400 MA, 400 Volt)
CR4	357-0004	1	Diode, Rectifier (400 MA, 400 Volt)
H1	812-0061	2	Screw, Machine, Round Head (#6-32 x 3/8")
H2	853-0003	2	Washer, Lock - External Tooth (#6)
H3	860-0006	2	Nut, Hex (#6-32)
Q1	362-0008	1	Transistor
Q2	362-0008	1	Transistor
Q3	362-0017	1	Transistor
Q4	362-0026	1	Transistor
Q5	362-0019	1	Transistor
R1	303-0171	1	Potentiometer (100,000-Ohm, 1/4 Watt)
R2	350-0560	1	Resistor, Composition (0.1 Megohm, 1/2 Watt, 10%)
R3	350-0548	1	Resistor, Composition (10,000-Ohm, 1/2 Watt, 10%)
R4	303-0171	1	Potentiometer (100,000-Ohm, 1/4 Watt)
R5	350-0558	1	Resistor, Composition (68,000-Ohm, 1/2 Watt, 10%)
R6	350-0420	1	Resistor, Composition (24,000-Ohm, 1/2 Watt, 5%)
R7	350-0546	1	Resistor, Composition (6800-Ohm, 1/2 Watt, 10%)
R8	350-0520	1	Resistor, Composition (47-Ohm, 1/2 Watt, 5%)
R9	350-0548	1	Resistor, Composition (10,000-Ohm, 1/2 Watt, 10%)
R10	350-0500	1	Resistor, Composition (1-Ohm, 1/2 Watt, 10%)
R11	352-0152	1	Resistor, Wirewound (25-Ohm, 5 Watt, 5%)
TB1	332-1275	1	Printed Wiring Board

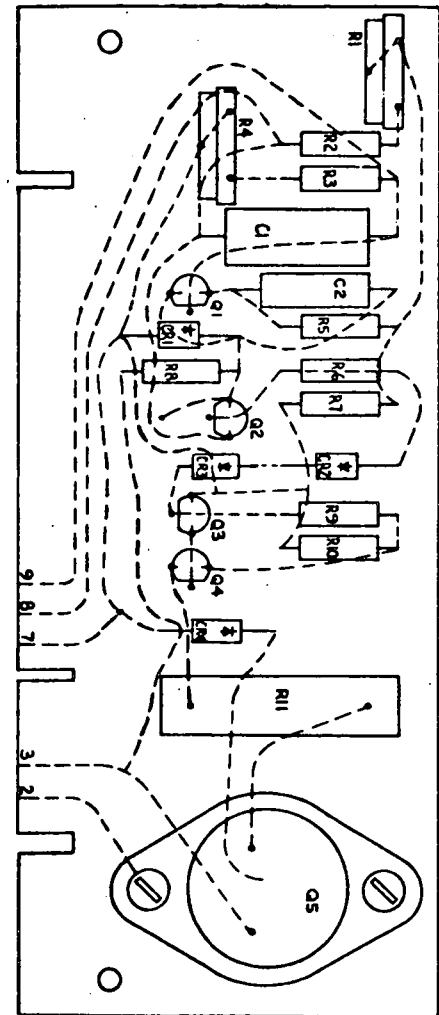

EXCITER ROTOR GROUP (BRUSHLESS GENERATOR)

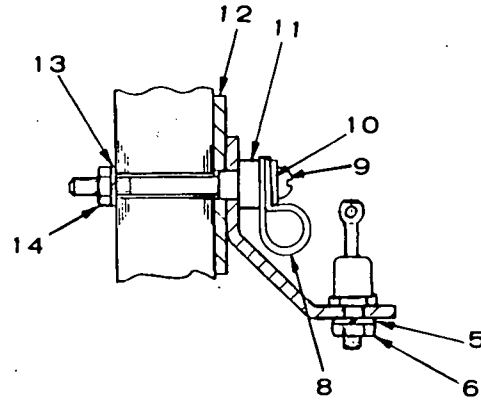
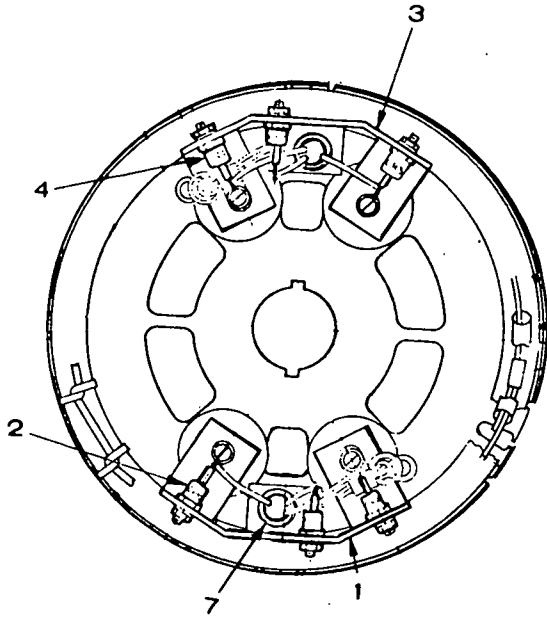

REF. NO.	PART NO.	QTY. USED	PART DESCRIPTION
	201-1739	1	Rotor Assembly, Wound - Exciter (Complete)
1	363-0055	1	Heat Sink, Rectifier - Negative
2	358-0015	3	Rectifier, Diode - Negative (CR4, CR5 & CR6)
3	363-0054	1	Heat Sink, Rectifier - Positive
4	358-0016	3	Rectifier, Diode - Positive (CR1, CR2 & CR3)
5	850-0030	6	Washer, Lock Spring (#10) Diode Mounting
6	870-0053	6	Nut, Hex - Diode Mounting (10-32)
7	508-0093	2	Grommet, Rubber
8	332-0050	2	Clip, Wire
9	813-0110	4	Screw, Roundhead - Heat Sink Mounting (10-32 x 2")
10	526-0009	4	Washer, Flat - Heat Sink Mounting (#10)
11	508-0124	4	Bushing, Insulating - Heat Sink Mounting
12	508-0156	4	Washer, Insulating - Heat Sink Mounting
13	850-0030	4	Washer, Lock Spring - Heat Sink Mounting (#10)
14	870-0053	4	Nut, Hex - Heat Sink Mtg. (10-32)

PRINTED CIRCUIT BOARD ASSEMBLY GROUP (AC)

332-1264 - Printed Circuit Board, Complete

BRUSH TYPE GENERATOR

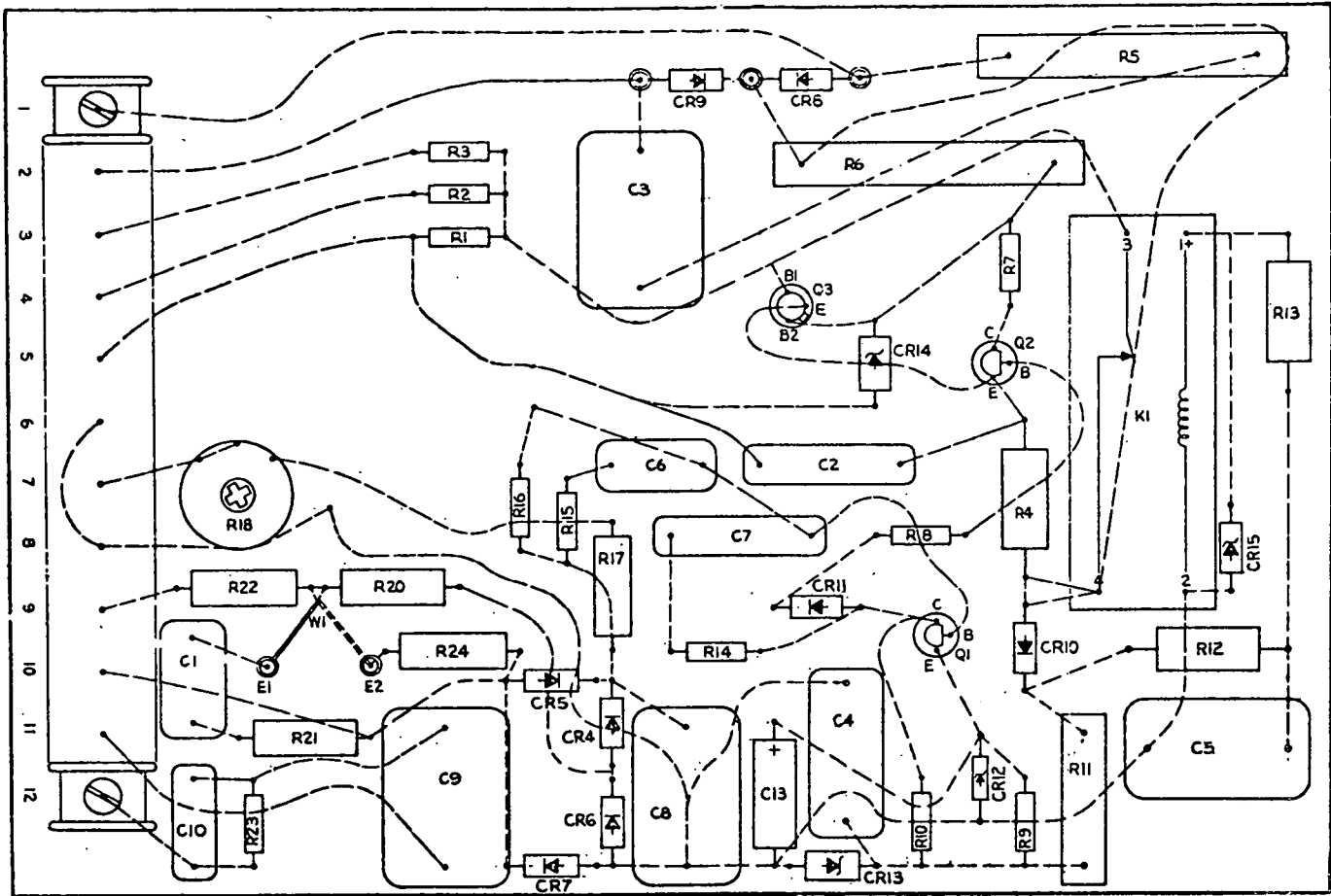

REF. NO.	PART NO.	QTY. USED	PART DESCRIPTION	REF. NO.	PART NO.	QTY. USED	PART DESCRIPTION
TB1	332-1252	1	Terminal Block	R6	353-0039	1	Resistor, Fixed (5,000-Ohm, 15 Watt)
C1	355-0018	1	Capacitor (.47 Mfd., 100 Volt)	R7	350-0398	1	Resistor (3,000-Ohm, 1/2 Watt)
C2, C7	355-0005	2	Capacitor (.22 Mfd., 200 Volt)	R8, R16	350-0447	2	Resistor (330,000-Ohm, 1/2 Watt)
C3, C9	355-0017	2	Capacitor (.47 Mfd., 400 Volt)	R9, R10	350-0423	2	Resistor (33,000-Ohm, 1/2 Watt)
C4	355-0006	1	Capacitor (.47 Mfd., 200 Volt)	R11	352-0151	1	Resistor, Fixed (15,000-Ohm, 5 Watt)
C5, C8	355-0016	2	Capacitor (1 Mfd., 100 Volt)	R12	350-1014	1	Resistor (13,000-Ohm, 2 Watt)
C6	355-0015	1	Capacitor (.1 Mfd., 200 Volt)	R13	350-1007	1	Resistor (6,800-Ohm, 2 Watt)
C10	355-0014	1	Capacitor (.047 Mfd., 200 Volt)	R14	350-0443	1	Resistor (220,000-Ohm, 2 Watt)
C13	356-0039	1	Capacitor (100 Mfd., 10 Volt)	R15	350-0435	1	Resistor (100,000-Ohm, 1/2 Watt)
CR4 thru 11	357-0014	8	Rectifier, Silicon	R17	351-0524	1	Resistor, Metal Film (13,000-Ohm, 1/4 Watt)
CR12	359-0035	1	Diode, Zener (6.8 Volt)	R18	303-0168	1	Potentiometer
CR13	359-0025	1	Diode, Zener (20 Volt)	R20, R22	351-0520	2	Resistor, Metal Film (28,000-Ohm, 1/4 Watt)
CR14	359-0026	1	Diode, Zener (18 Volt)	R21	351-0522	1	Resistor, Metal Film (5,110-Ohm, 1/4 Watt)
CR15	359-0015	1	Diode, Zener (24 Volt)	R24	351-0523	1	Resistor, Metal Film (8,870-Ohm, 1/4 Watt)
K1	307-1063	1	Relay, Magnetic Reed				
Q1, Q2	362-0017	2	Transistor, Silicon (NPN)				
Q3	361-0004	1	Transistor, Unijunction				
R1, R23	350-0355	2	Resistor (47-Ohm, 1/2 Watt)				
R2, R3	350-0351	2	Resistor (33-Ohm, 1/2 Watt)				
R4	350-1075	1	Resistor (4.7-Megohm, 2 Watt)				
R5	353-0040	1	Resistor, Fixed (270-Ohm, 10 Watt)				

PRINTED CIRCUIT BOARD ASSEMBLY GROUP (AC,

332-1268 - Printed Circuit Board, Complete

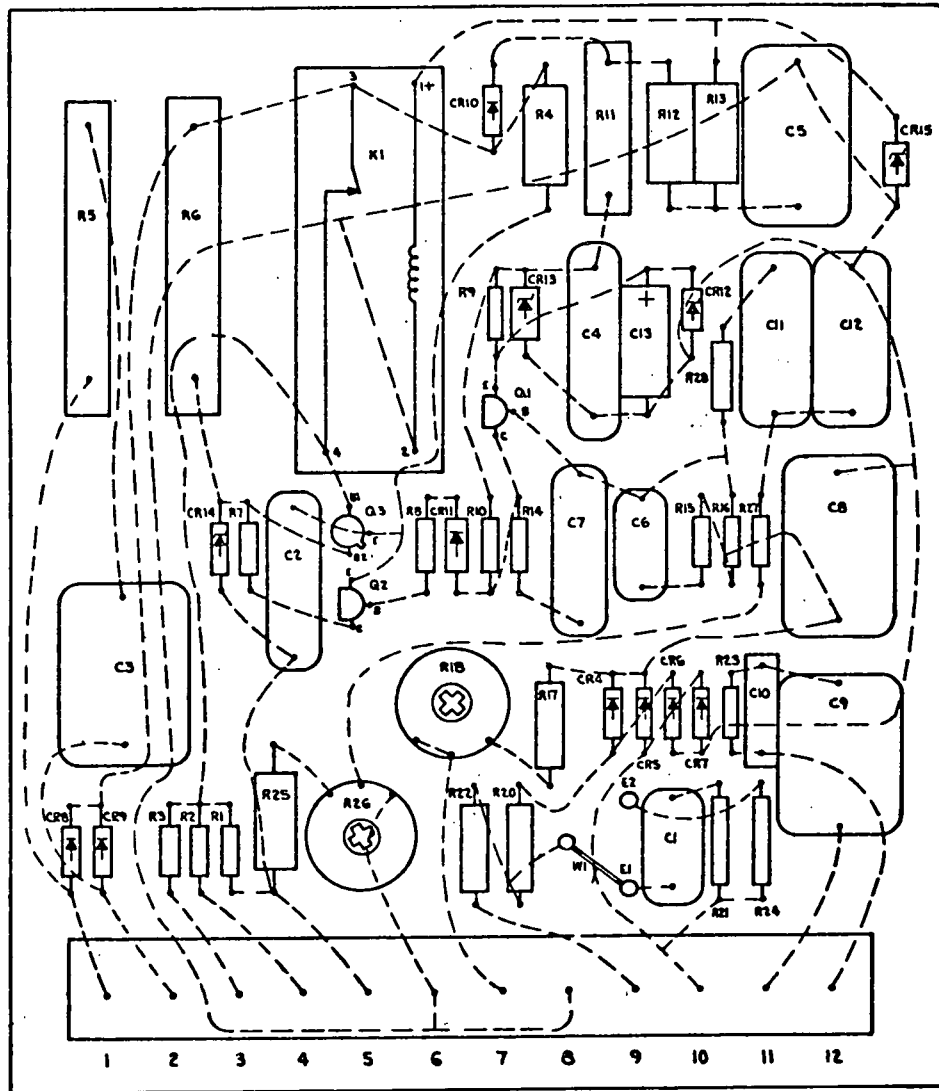

REF. NO.	PART NO.	QTY. USED	PART DESCRIPTION	REF. NO.	PART NO.	QTY. USED	PART DESCRIPTION
TB1	332-1252	1	Terminal Block	R6	353-0039	1	Resistor, Fixed (5,000-Ohm, 15 Watt)
C1	355-0018	1	Capacitor (.47 Mfd., 100 Volt)	R7	350-0398	1	Resistor (3,000-Ohm, 1/2 Watt)
C2, C7	355-0005	2	Capacitor (.22 Mfd., 200 Volt)	R8, R16	350-0447	2	Resistor (330,000-Ohm, 1/2 Watt)
C3, C9	355-0017	2	Capacitor (.47 Mfd., 400 Volt)	R9, R10	350-0423	2	Resistor (33,000-Ohm, 1/2 Watt)
C4, C12	355-0006	2	Capacitor (.47 Mfd., 200 Volt)	R11, R12	352-0151	2	Resistor, Fixed (15,000-Ohm, 5 Watt)
C5, C8	355-0016	2	Capacitor (1 Mfd., 100 Volt)	R13	350-1007	1	Resistor (6,800-Ohm, 2 Watt)
C6	355-0015	1	Capacitor (.1 Mfd., 200 Volt)	R14	350-0443	1	Resistor (220,000-Ohm, 2 Watt)
C10	355-0014	1	Capacitor (.047 Mfd., 200 Volt)	R15, R27	350-0435	2	Resistor (100,000-Ohm, 1/2 Watt)
C11	355-0020	1	Capacitor (.1 Mfd., 400 Volt)	R17	351-0521	1	Resistor, Metal Film (12,100 Ohm, 1/4 Watt)
C13	356-0039	1	Capacitor (100 Mfd., 10 Volt)	R18	303-0168	1	Potentiometer
CR4 thru 11	357-0014	8	Rectifier, Silicon	R20, R22	351-0520	2	Resistor, Metal Film (28,000-Ohm, 1/4 Watt)
CR12	359-0016	1	Diode, Zener (6.8 Volt)	R21	351-0522	1	Resistor, Metal Film (5,110-Ohm, 1/4 Watt)
CR13	359-0025	1	Diode, Zener (20 Volt)	R24	351-0523	1	Resistor, Metal Film (8,870-Ohm, 1/4 Watt)
CR14	359-0026	1	Diode, Zener (18 Volt)	R25	350-1011	1	Resistor (10,000-Ohm, 2 Watt)
CR15	359-0015	1	Diode, Zener (24 Volt)	R26	303-0164	1	Potentiometer
K1	307-1063	1	Relay, Magnetic Reed	R28	350-0459	1	Resistor (1.0 Megohm, 1 Watt)
Q1, Q2	362-0017	2	Transistor, Silicon (NPN)		517-0127	2	Cover, Potentiometer (Not Illustrated)
Q3	361-0004	1	Transistor, Unijunction				
R1, R23	350-0355	2	Resistor (47-Ohm, 1/2 Watt)				
R2, R3	350-0351	2	Resistor (33-Ohm, 1/2 Watt)				
R4	350-1075	1	Resistor (4.7 Megohm, 2 Watt)				
R5	353-0040	1	Resistor, Fixed (270-Ohm, 10 Watt)				

MOUNTED FUEL TANK ASSEMBLY

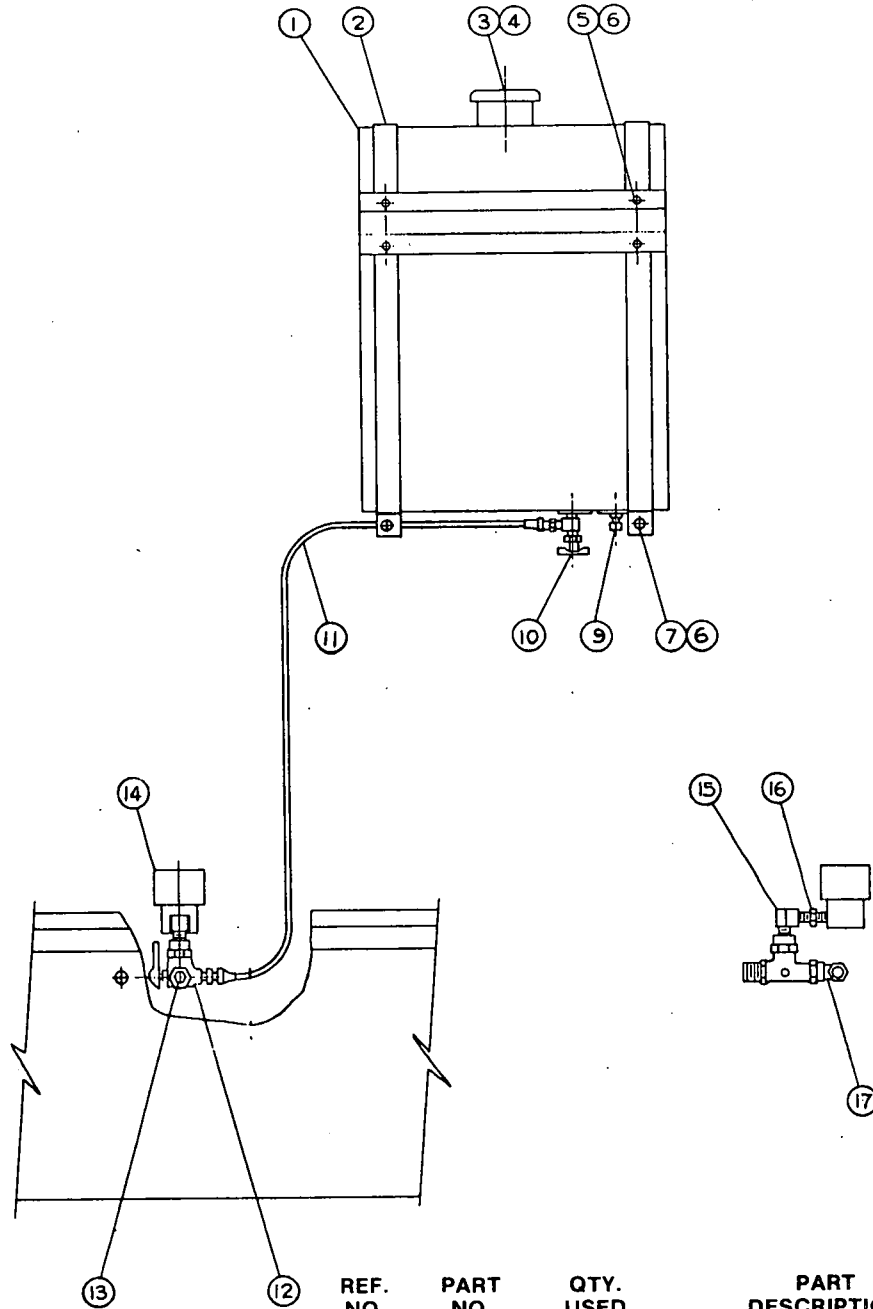

REF. NO.	PART NO.	QTY. USED	PART DESCRIPTION
1	159-0490	1	Tank, Fuel (20 Gal.)
2	159-0489	1	Strap Assembly, Fuel Tank
3	159-0512	1	Cap & Indicator Assembly
4	159-0751	1	Gasket, Fuel Tank Filler Neck
5	812-0150	8	Screw (1/4-20 x 5/8") - Roundhead Sheet Metal
6	850-0040	10	Washer, Lock (1/4)
7	812-0158	2	Screw (1/4-20 x 2") - Roundhead Sheet Metal
9	505-0057	1	Plug, Pipe (1/8)
10	504-0007	1	Valve, Shut-off
11	501-0011	1	Line, Fuel (52") - Flexible
12	504-0004	1	Valve
13	505-0274	1	Plug, Hex (1/8)
14	307-0565	1	Valve, Fuel Solenoid
15	502-0020	1	Elbow, Inverted
16	502-0082	1	Nipple, Hex
17	502-0002	1	Elbow, Inverted

CITY WATER COOLING INSTALLATION — UNHOUSED (OPTIONAL)

179-0216

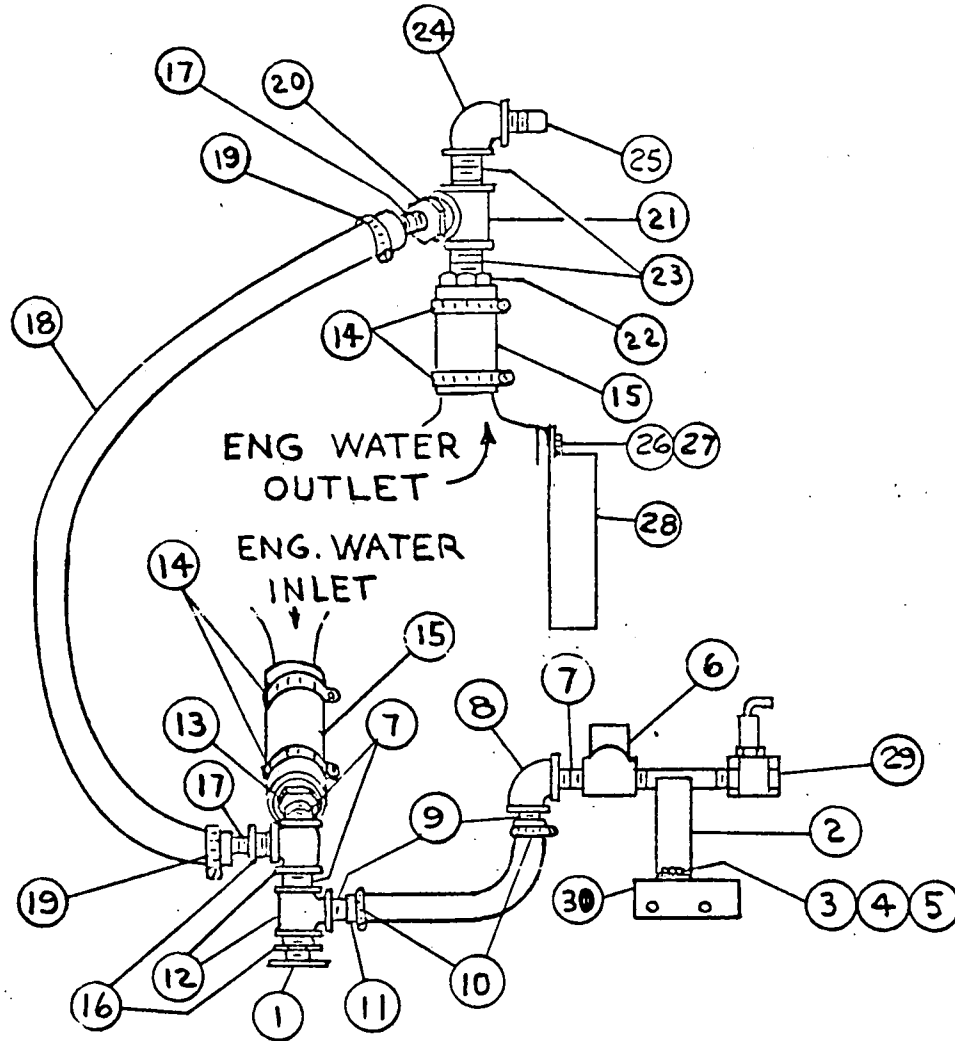

REF. NO.	PART NO.	QTY. USED	PART DESCRIPTION	REF. NO.	PART NO.	QTY. USED	PART DESCRIPTION
1	504-0003	1	Valve, Drain	16	505-0018	2	Bushing, Reducer (1/2 x 1/4)
2	110-0526	1	Nipple & Bracket Assembly	17	505-0010	2	Nipple, Half (1/4 x 1")
3	800-0007	2	Screw (1/4-20 x 1")	18		1	Hose, Water (Order 30" of Bulk Hose #503-0110)
4	850-0040	2	Washer, Lock (1/4")	19	503-0032	2	Clamp, Hose
5	862-0001	2	Nut, Hex (1/4-20)	20	505-0020	1	Bushing, Reducer (3/4 x 1/4)
6	307-0833	1	Valve, Water	21	505-0166	1	Tee (3/4)
7	505-0100	3	Nipple, Close (1/2")	22	110-1543	1	Adapter
8	505-0040	1	Elbow (1/2 x 90°)	23	505-0102	2	Nipple, Close (3/4)
9	505-0185	2	Nipple, Half (1/2 x 1-1/2)	24	505-0132	1	Elbow (3/4 x 90°)
10	503-0189	2	Clamp, Hose	25	505-0324	1	Nipple, Half (3/4 x 2")
11		1	Hose, Water (Order 11" of Bulk Hose #503-0191)	26	850-0055	2	Washer, Lock (7/16)
12	505-0108	2	Tee (1/2)	27	800-0069	2	Screw (7/16-14 x 3/4)
13	110-0576	1	Adapter, Hose	28	130-0782	1	Guard, Belt
14	503-0365	4	Clamp, Hose	29	504-0019	1	Valve
15		2	Hose, Water (Order 3" of Bulk Hose #503-0356)	30	130-0499	1	Bracket, Heat Exchanger

WATER JACKET HEATER INSTALLATION (OPTIONAL)

179-0218

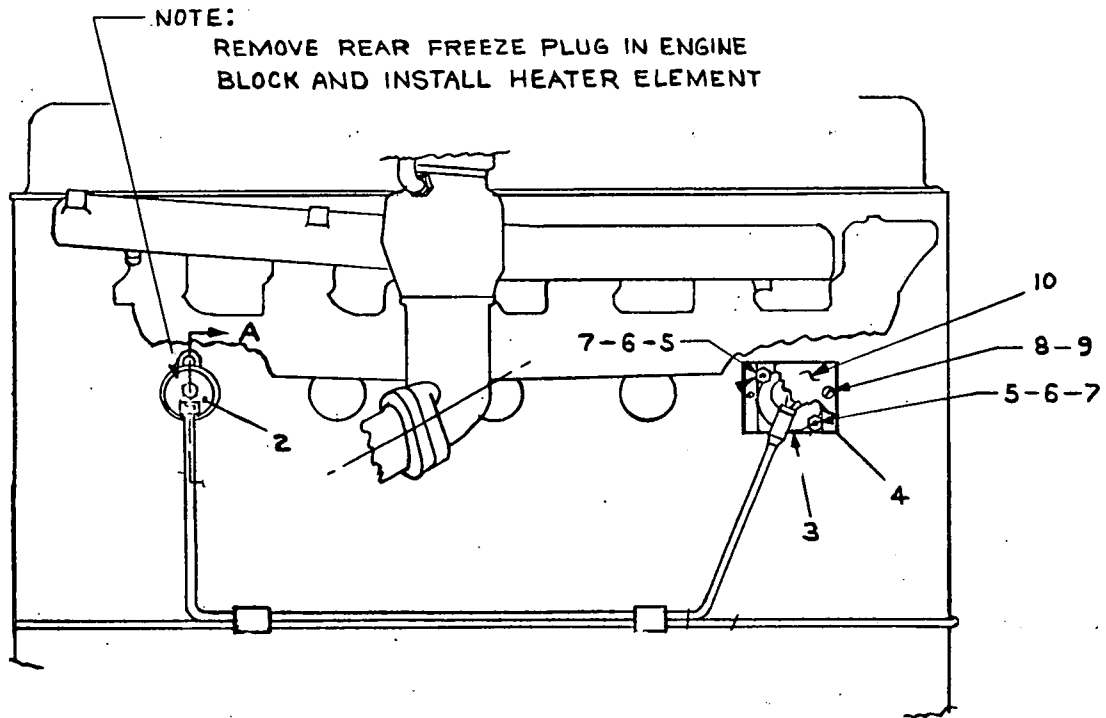

REF. NO.	PART NO.	QTY. USED	PART DESCRIPTION
2	333-0118	1	Kit, Engine Heater
3	309-0106	1	Thermostat
4	333-0012	1	Box, Thermostat
5	520-0446	2	Stud (3/16 x 3/4")
6	850-0030	2	Washer, Lock (#10)
7	870-0053	2	Nut, Hex (10-32)
8	850-0025	2	Washer, Lock (#8)
9	812-0075	2	Screw, Roundhead Sheet Metal (8-32 x 1/4")
10	333-0013	1	Cover, Thermostat Box

STANDPIPE COOLING INSTALLATION (OPTIONAL)

179-0225

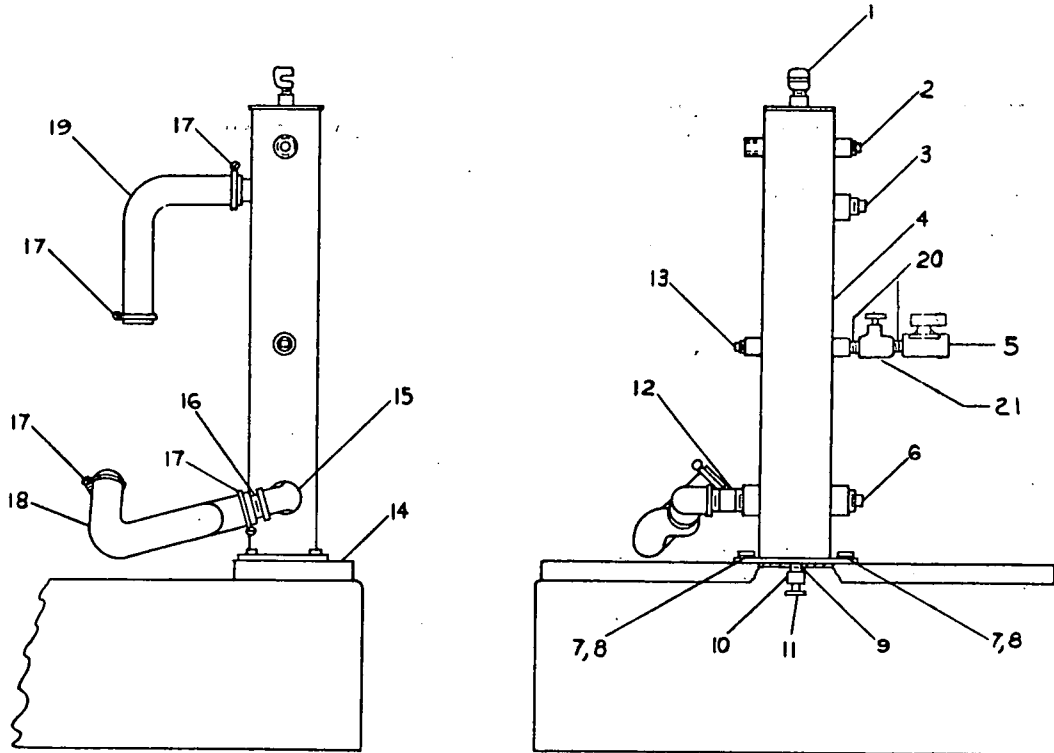

REF. NO.	PART NO.	QTY. USED	PART DESCRIPTION
1	504-0062	1	Valve, Vacuum Relief
2	505-0130	1	Plug (3/4)
3	505-0140	1	Plug (1")
4	130-0659	1	Standpipe
5	307-0833	1	Valve, Water (12 Volt)
6	505-0359	1	Plug (1-1/4)
7	850-0050	4	Washer, Lock (3/8)
8	800-0048	4	Screw (3/8-16 x 3/4") - Hex Head Cap
9	505-0101	1	Nipple, Close (3/8)
10	505-0028	1	Coupling (3/8)
11	504-0028	1	Valve, Drain
12	505-0258	1	Nipple (1-1/4 x 3")
13	505-0056	1	Plug, Steel (1/2)
14	130-0636	1	Support, Standpipe
15	505-0183	1	Elbow, Reducer (1-1/2 x 1-1/4)
16	505-0385	1	Nipple, Half (1-1/2)
17	503-0365	4	Clamp, Hose
18	503-0490	1	Hose (1-3/4 x 15-1/2")
19	503-0491	1	Hose (1-3/4" ID - Molded)
20	505-0100	2	Nipple, Close (1/2)
21	504-0019	1	Valve, Globe

ENGINE HEATER INSTALLATION—OPTIONAL EQUIPMENT

179-0299

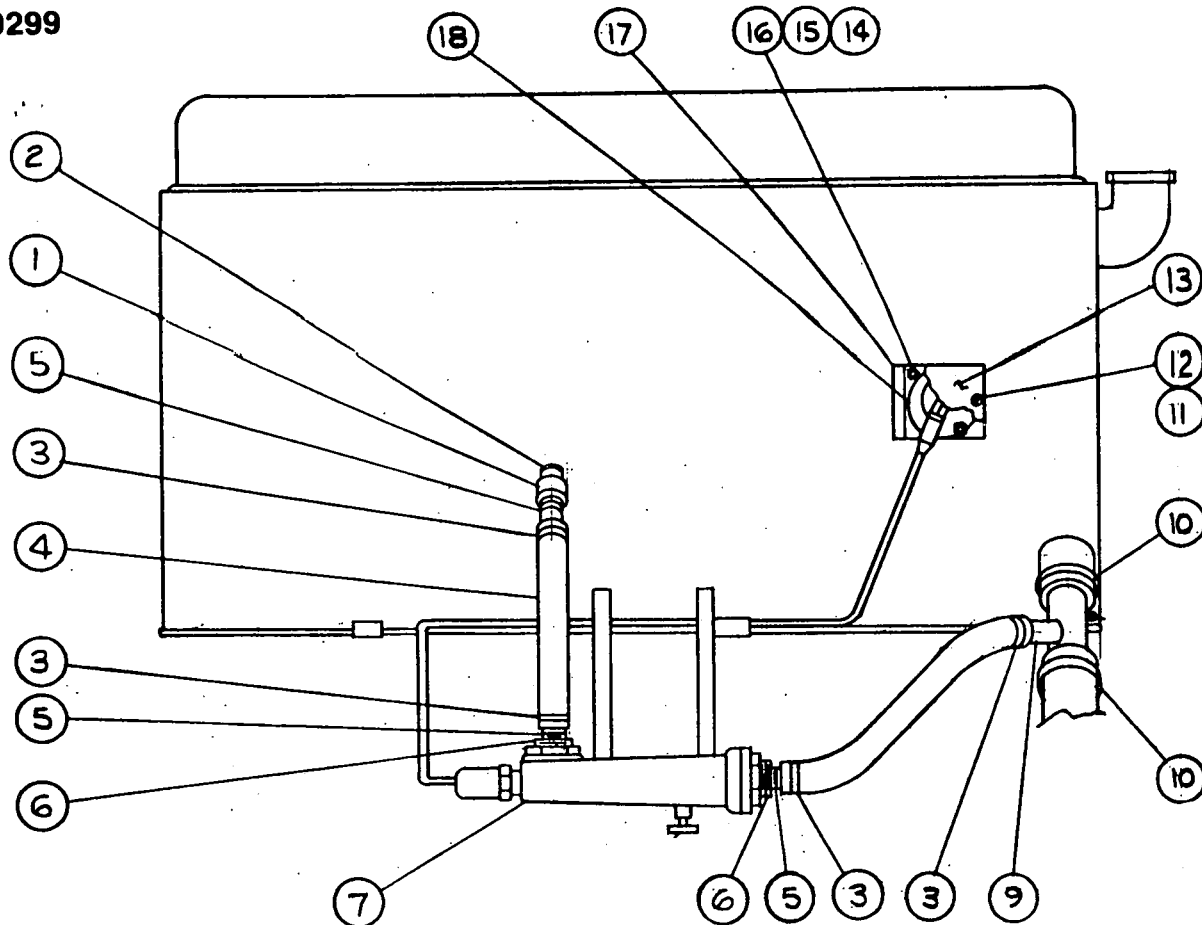

REF. NO.	PART NO.	QTY. USED	PART DESCRIPTION
1	505-0190	1	Elbow (1/2 x 45°)
2	505-0106	1	Nipple, Short - (1/2 x 1-1/2")
3	503-0189	4	Clamp, Hose
4		1	Hose, Water (Order 18" of #503-0191 Hose)
5	505-0185	3	Nipple, Half - (1/2")
6	505-0021	2	Bushing, Reducer - (1/2 x 3/4")
7	333-0093	1	Heater, Engine
8		1	Hose, Water (Order 18" of #503-0191 Hose)
9	503-0517	1	Adapter, Hose
10	503-0311	2	Clamp, Hose
11	850-0025	2	Washer, Lock - (#8)
12	812-0075	2	Screw, Round Head - (8-32 x 1/4")
13	333-0013	1	Cover, Thermostat Box
14	520-0446	2	Stud - Thermostat Box Mounting (#10-32 x 3/4")
15	850-0030	2	Washer, Lock - (#10)
16	870-0053	2	Nut (10-32)
17	333-0012	1	Box, Thermostat
18	309-0029	1	Thermostat

STANDPIPE COOLING WITH MARSH REGULATOR INSTALLATION (OPTIONAL)

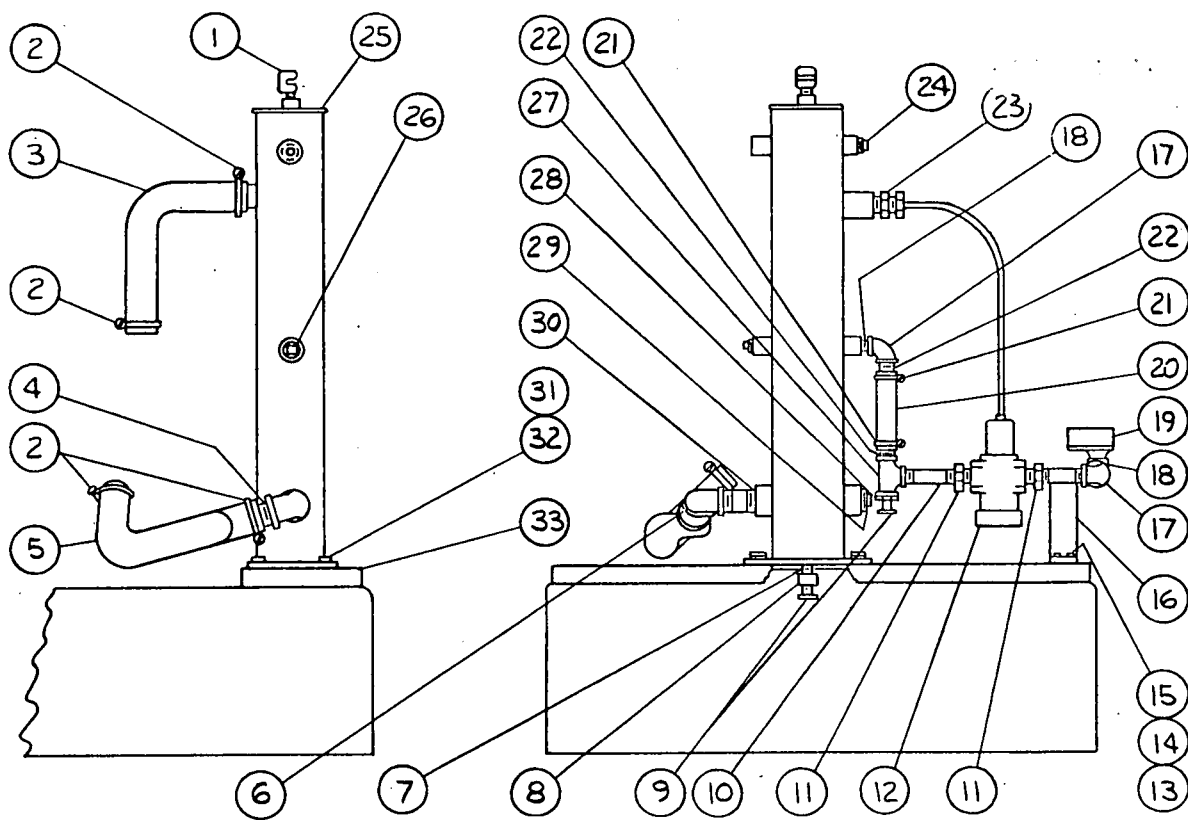

REF. NO.	PART NO.	QTY. USED	PART DESCRIPTION
1	504-0062	1	Valve, Vacuum Relief
2	503-0365	4	Clamp, Hose
3	503-0491	1	Hose, Water
4	505-0385	1	Nipple, Half (1-1/2")
5	503-0490	1	Hose, Water
6	505-0183	1	Elbow, Reducer (1-1/2 x 1-1/4)
7	505-0101	1	Nipple, Close (3/8)
8	505-0028	1	Coupling (3/8)
9	504-0028	2	Valve, Drain
10	505-0002	1	Nipple, Pipe (1/2 x 3")
11	505-0021	2	Bushing, Reducer (3/4 x 1/2)
12	309-0241	1	Valve, Water Temperature Control (Marsh)
13	800-0027	2	Screw, Hex Head Cap - (5/16-18 x 7/8")
14	850-0045	2	Washer, Lock (5/16)
15	862-0015	2	Nut, Hex (5/16-18)
16	110-0526	1	Nipple Assembly, Waterline
17	505-0040	2	Elbow (1/2)

REF. NO.	PART NO.	QTY. USED	PART DESCRIPTION
18	505-0100	2	Nipple, Close (1/2)
19	307-0833	1	Valve, Water (12 Volt)
20	503-0437	1	Hose, Water
21	503-0189	2	Clamp, Hose
22	505-0185	2	Nipple, Half (1/2")
23	505-0129	1	Bushing, Reducer (1" x 3/4)
24	505-0130	1	Plug, Square Head (3/4)
25	130-0659	1	Standpipe
26	505-0056	1	Plug, Steel (1/2)
27	505-0108	1	Tee (1/2)
28	505-0019	1	Bushing, Reducer (1/2 x 3/8)
29	505-0359	1	Plug, Square Head (1-1/4)
30	505-0258	1	Nipple, Pipe (1-1/4 x 3")
31	850-0050	4	Washer, Lock (3/8)
32	800-0048	4	Screw, Hex Head Cap - (3/8-16 x 3/4")
33	130-0636	1	Bracket, Standpipe Mounting
34	130-0782	1	Guard, Belt
35	800-0069	2	Screw (7/16-14 x 3/4") -
36	850-0055	2	Washer, Lock (7/16) -

HEAT EXCHANGER WITH MARSH REGULATOR INSTALLATION (OPTIONAL)

179-0329

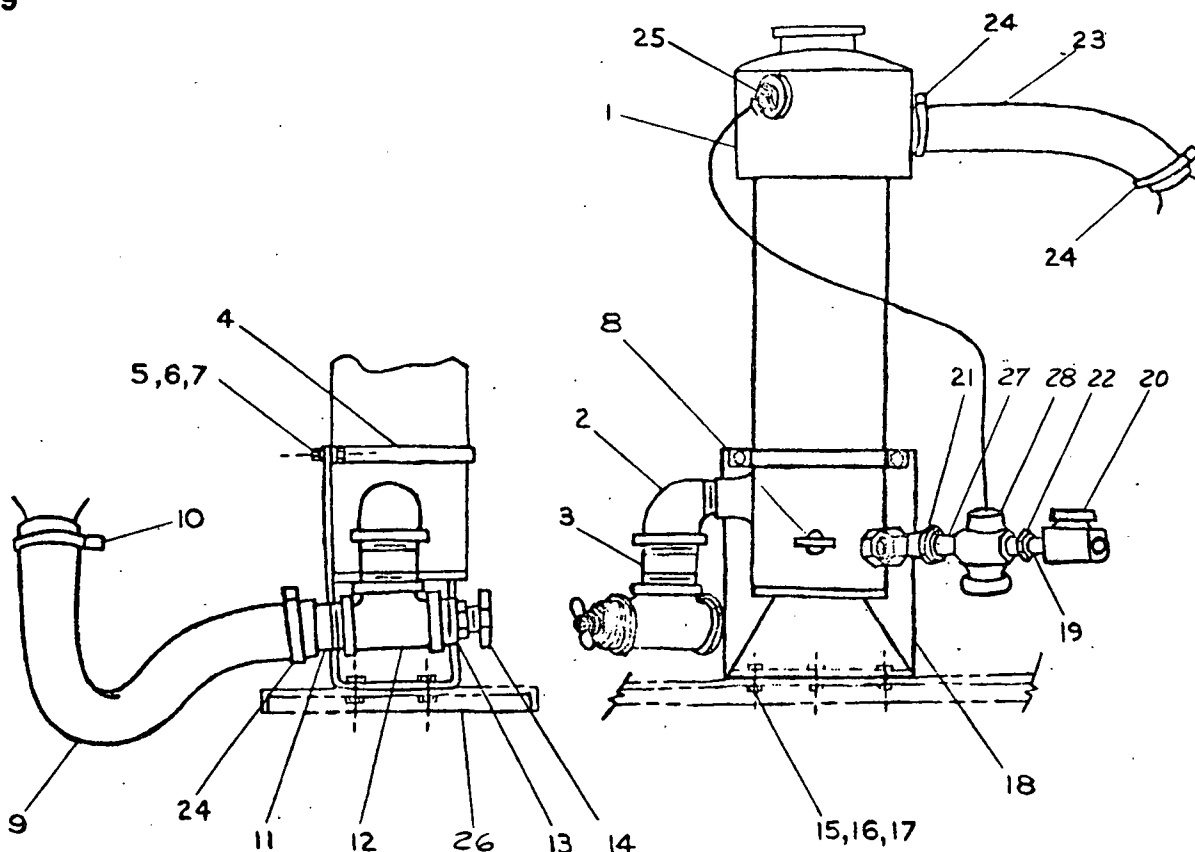

NOTE: 1. Not Shown on Drawing.

REF. NO.	PART NO.	QTY. USED	PART DESCRIPTION	REF. NO.	PART NO.	QTY. USED	PART DESCRIPTION
1	130-0796	1	Exchanger, Heat	17	862-0015	2	Nut, Hex (5/16-18)
2	505-0462	1	Elbow, Street (1/2 x 90°)	18	130-0803	1	Bracket, Heat Exchanger Mounting
3	505-0220	1	Nipple (1-1/2 x 1-3/4")	19	505-0100	1	Nipple (1/2 x 1-1/8")
4	130-0802	1	Strap, Heat Exchanger Mounting	20	307-0833	1	Valve, Solenoid
5	800-0004	2	Screw, Hex Head Cap - (1/4-20 x 5/8")	21	505-0691	1	Elbow, Street (3/4 x 45°)
6	850-0040	2	Washer, Lock (1/4)	22	505-0021	1	Bushing, Reducer (3/4 x 1/2)
7	862-0001	2	Nut, Hex (1/4-20)	23	503-0491	1	Hose, Radiator (1-3/4 ID - Molded)
8	504-0005	1	Valve, Drain (1/8 NPT)	24	503-0311	3	Clamp, Hose
9	503-0490	1	Hose, Radiator (1-3/4" ID x 15-1/2")	25	505-0129	1	Bushing, Reducer (1 x 3/4)
10	503-0269	1	Clamp, Hose	26	130-0805	1	Bracket, Heat Exchanger
11	505-0444	1	Nipple, Half (1-1/2 x 2-1/4")	27	505-0102	1	Nipple, Close (3/4)
12	505-0317	1	Tee (1-1/2")	28	309-0241	1	Valve, Water Temperature Control
13	505-0426	1	Bushing, Reducer (1-1/2 x 1/4)		850-0055	2	Washer, Lock (7/16) - (See Note 1)
14	504-0003	1	Valve, Drain (1/4 NPT)		800-0069	2	Screw (7/16-14 x 3/4") - (See Note 1)
15	800-0026	2	Screw, Hex Head Cap - (5/16-18 x 3/4")		130-0782	1	Guard, Belt (See Note 1)
16	850-0045	2	Washer, Lock (5/16")				

EXHAUST MUFFLER INSTALLATION — TOP MOUNTED (OPTIONAL)

179-0355

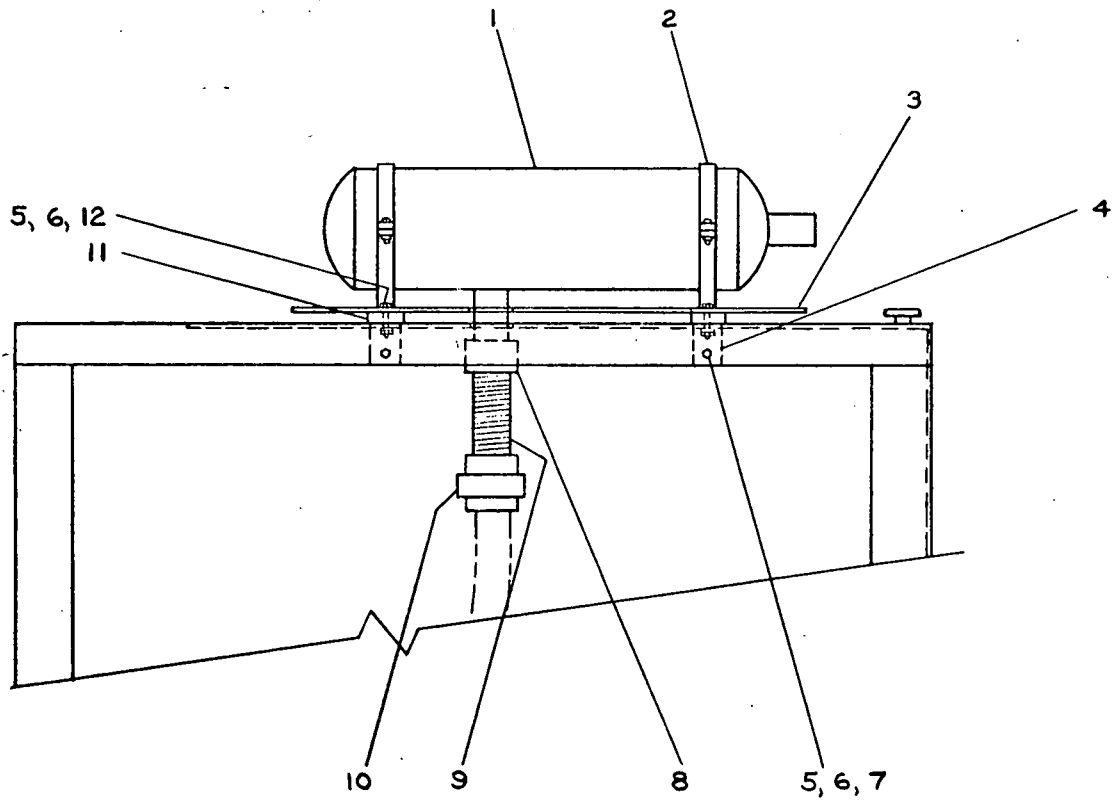

REF. NO.	PART NO.	QTY. USED	PART DESCRIPTION
1	155-0988	1	Muffler
2	140-0649	2	Band
3	155-0978	1	Shield, Heat
4	155-0789	2	Support
5	862-0015	10	Nut (5/16-18)
6	850-0045	10	Washer, Lock (5/16)
7	800-0026	6	Screw (5/16-18 x 3/4")
8	505-0203	1	Coupling (2")
9	155-1112	1	Tube Assembly, Exhaust
10	505-0454	1	Union (2")
11	526-0172	8	Spacer
12	800-0028	4	Screw (5/16-18 x 1")
13	155-1383	1	Shield, Rain

WATER COOLED MANIFOLD INSTALLATION (OPTIONAL)

179-0362

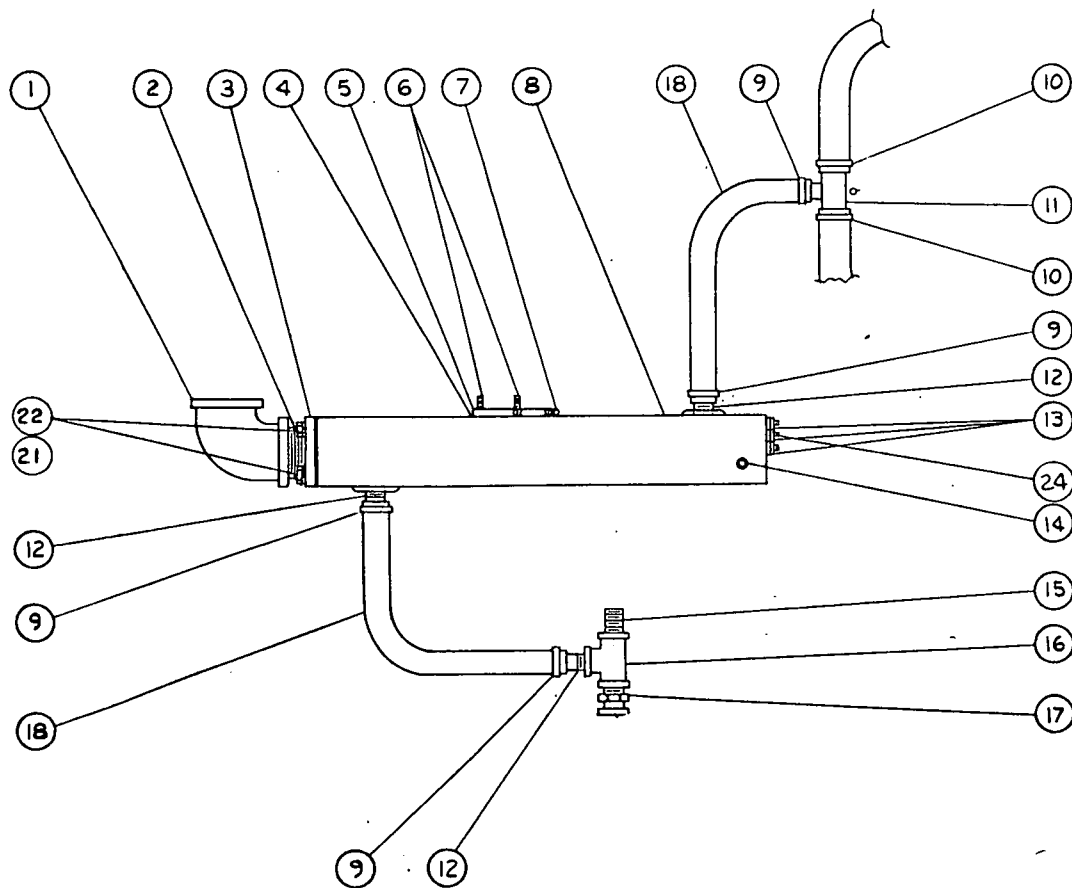

REF. NO.	PART NO.	QTY. USED	PART DESCRIPTION
1	505-0175	1	Elbow (2" x 90°)
2	505-0172	1	Nipple, Close (2")
3	154-1335	1	Flange, Exhaust Manifold
4	145-0120	1	Gasket, Carburetor
5		1	Mount, Carburetor (Included With Item 8)
6	520-0311	2	Stud (3/8 x 1-5/8")
7	505-0271	1	Nipple (1/4 x 3-1/2")
8	154-1334	1	Manifold, Water Cooled
9	503-0189	4	Clamp, Hose
10	503-0269	2	Clamp, Hose (2-1/4 x 1/2")
11	503-0517	1	Adapter, Hose
12	505-0185	3	Nipple, Half (1/2 x 1-1/2")
13	526-0030	3	Washer, Flat (3/8")
14	505-0057	1	Plug (1/8")
15	505-0106	1	Nipple, Short (1/2 x 1-1/2") (See Note 3)
16	505-0108	1	Tee (1/2")
17	505-0018	1	Bushing, Reducer (1/2 x 1/4)
18		2	Hose, Water (Order 14" of Bulk Hose #503-0191)
19	511-0078	1	Belt, Governor (See Note 2)
20	520-0515	1	Linkage, Governor (See Note 2)
21	800-0051	4	Screw (3/8-16 x 1-1/4") - Hex Head Cap
22	526-0066	4	Washer, Flat (3/8)
23	801-0027	4	Screw (5/16-24 x 7/8") (See Note 4)
24	520-0238	2	Stud (3/8 x 1-13/16")

CITY WATER COOLING WITH WATER COOLED MANIFOLD INSTALLATION — UNHOUSED (OPTIONAL)

179-0365

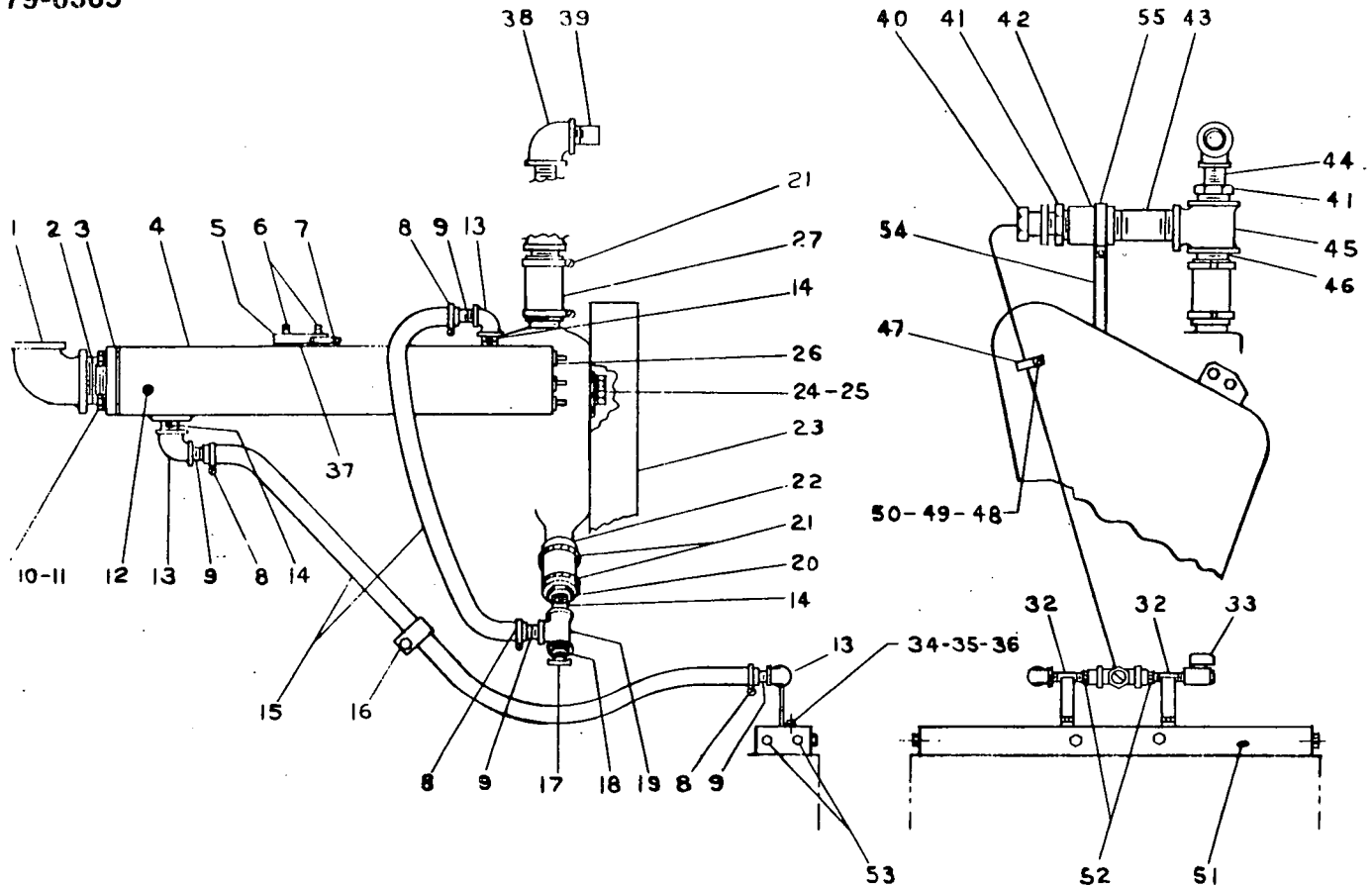

REF. NO.	PART NO.	QTY. USED	PART DESCRIPTION	REF. NO.	PART NO.	QTY. USED	PART DESCRIPTION
1	505-0175	1	Elbow (2 x 90°)	32	110-0526	2	Bracket & Nipple Assembly
2	505-0172	1	Nipple (2 x 2), Close	33	307-0833	1	Valve, Solenoid
3	154-1335	1	Flange, Exhaust Manifold	34	800-0005	4	Screw (1/4-20 x 3/4")
4	154-1334	1	Manifold, Exhaust - Water Cooled	35	850-0040	4	Washer (1/4"), Lock
5		1	Mount, Carburetor (Included with Item 4)	36	862-0001	4	Nut (1/4-20)
6	520-0311	2	Stud (3/8 x 1-5/8")	37	145-0120	1	Gasket, Carburetor
7	505-0271	1	Nipple (1/4 x 3-1/2")	38	505-0051	1	Elbow (3/4 x 90°)
8	503-0189	4	Clamp, Hose	39	505-0324	1	Nipple (3/4"), Half
9	505-0185	4	Nipple (1/2 x 1-1/2") - Half	40	309-0241	1	Valve, Water Temperature Control
10	850-0050	7	Washer (3/8"), Lock	41	505-0289	2	Bushing, Reducer
11	800-0052	4	Screw (3/8-16 x 1-1/2")	42	505-0032	1	Coupling (1-1/2")
12	505-0057	1	Plug (1/8")	43	505-0109	1	Nipple (1-1/2 x 2-1/2")
13	505-0040	3	Elbow (1/2")	44	505-0102	1	Nipple (3/3"), Close
14	505-0100	3	Nipple (1/2"), Close	45	505-0317	1	Tee (1-1/2")
15		1	Hose, Water (Order 63" of Bulk Hose #503-0191)	46	505-0385	1	Nipple (1-1/2"), Half
16	148-0274	1	Bracket, Hose	47	332-0050	1	Clip, Wire
17	504-0003	1	Valve, Drain	48	812-0079	1	Screw (8-32 x 1/2"), Round Head
18	505-0018	1	Bushing, Reducer - (1/2 x 1/4)	49	850-0025	1	Washer (#8), Lock
19	505-0108	1	Tee (1/2")	50	860-0009	1	Nut (#8-32)
20	110-0576	1	Plug, Hose Adapter	51	130-0499	1	Bracket, Heat Exchanger
21	503-0365	4	Clamp, Hose	52	505-0021	2	Bushing (3/4 x 1/2"), Reducer
22		1	Hose, Water (Order 3" of Bulk Hose #503-0356)	53	821-0014	6	Screw, Lock - (5/16-18 x 1/2")
23	130-0782	1	Guard, Belt	54	130-0757	1	Bracket, Tee, Support
24	850-0055	2	Washer (7/16"), Lock	55	130-0522	1	Clamp
25	800-0069	2	Screw (7/16-14 x 3/4")		526-0030	3	*Washer - Governor Mounting
26	526-0029	3	Washer (7/16-14 x 3/4")		518-0178	1	*Clip, Cable - Solenoid Lead
27		1	Hose, Water (Order 2" of Bulk Hose #503-0356)		520-0515	1	*Stud - Governor Link
					511-0078	1	*Belt, Vee - Governor

HEAT EXCHANGER INSTALLATION (OPTIONAL)

179-0370

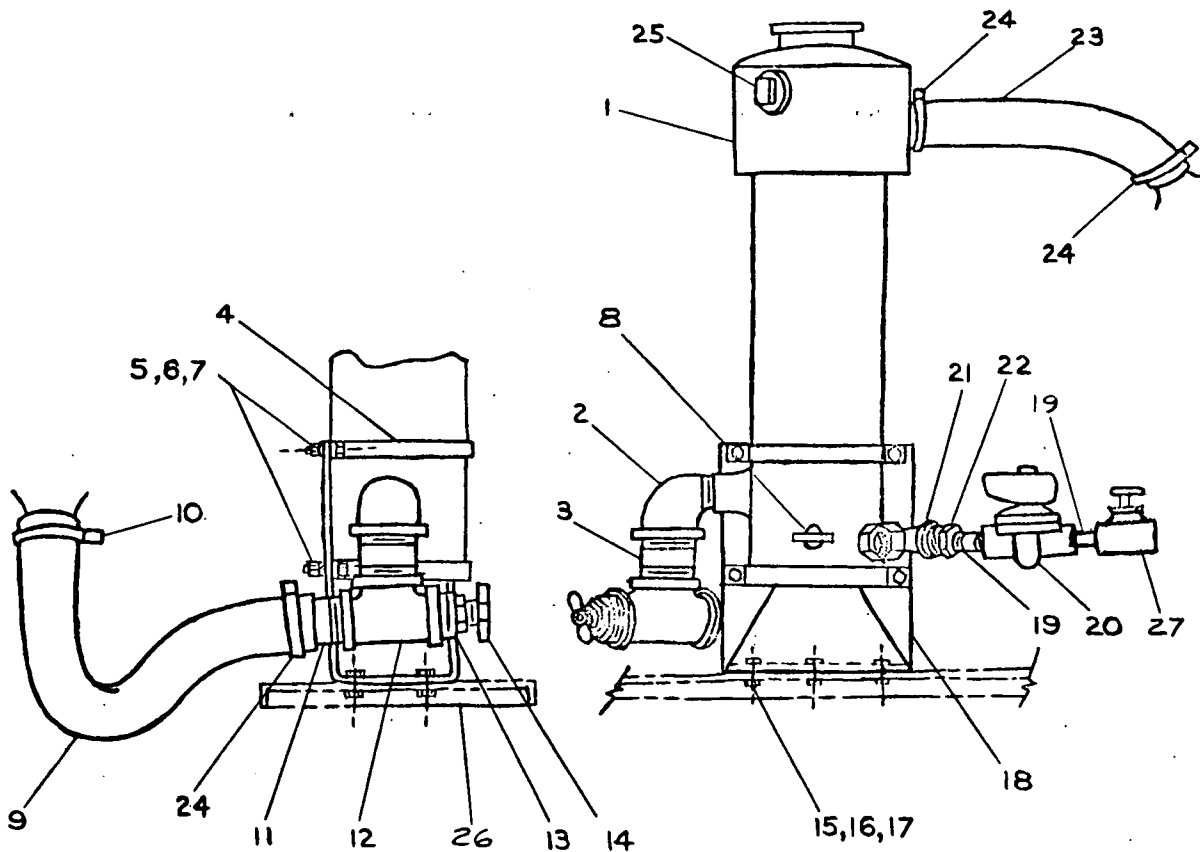

REF. NO.	PART NO.	QTY. USED	PART DESCRIPTION
1	130-0796	1	Exchanger, Heat
2	505-0462	1	Elbow, Street (1-1/2 x 90°)
3	505-0642	1	Nipple (1-1/2 x 4")
4	130-0802	2	Strap, Heat Exchanger Mounting
5	800-0004	4	Screw (1/4-20 x 5/8")
6	850-0040	4	Washer, Lock (1/4)
7	862-0001	4	Nut, Hex (1/4-20)
8	504-0005	1	Valve, Drain (1/8 NPT)
9	503-0490	1	Hose, Radiator (1-3/4 ID x 15-1/2")
10	503-0269	1	Clamp, Hose
11	505-0444	1	Nipple, Half (1-1/2" x 2-1/4")
12	505-0317	1	Tee (1-1/2")
13	505-0426	1	Bushing, Reducer (1-1/2 x 1/4)
14	504-0003	1	Valve, Drain (1/4 NPT)
15	800-0026	2	Screw, Hex Head Cap - (5/16-18 x 3/4")

REF. NO.	PART NO.	QTY. USED	PART DESCRIPTION
16	850-0045	2	Washer, Lock (5/16)
17	862-0015	2	Nut, Hex (5/16-18)
18	130-0819	1	Bracket, Heat Exchanger Mounting
19	505-0100	2	Nipple (1/2 x 1-1/8")
20	307-0833	1	Valve, Solenoid
21	505-0691	1	Elbow, Street (3/4 x 45°)
22	505-0021	1	Bushing, Reducer (3/4 x 1/2)
23	503-0491	1	Hose, Radiator (1-3/4 ID - Molded)
24	503-0311	3	Clamp, Hose
25	505-0140	1	Plug (1")
26	130-0805	1	Bracket, Heat Exchanger
27	504-0019	1	Valve, Globe
29	850-0055	2	Washer, Lock (7/16) -
30	800-0069	2	Screw, Hex Head Cap - (7/16-14 x 3/4") -
31	130-0782	1	Guard, Belt

ENGINE CONTROL MONITOR GROUP - 12 VOLT (STANDARD SETS WITH ONE FAULT LIGHT)

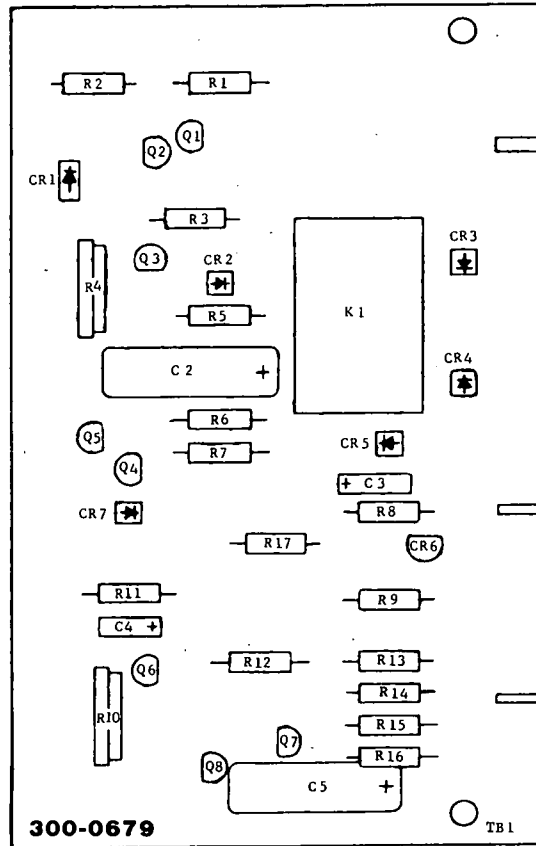

REF. NO.	PART NO.	QTY. USED	PART DESCRIPTION	REF. NO.	PART NO.	QTY. USED	PART DESCRIPTION
	300-0679		Monitor, Engine Control - 12 Volt	R1	350-0536	1	Resistor, Composition (1000-Ohm, 1/2 Watt, 10%)
C1			Not used	R2	350-0526	1	Resistor, Composition (100-Ohm, 1/2 Watt, 10%)
C2	355-0005	1	Capacitor, Plastic Dielectric (.22 Mfd, 200 VDC, 10%)	R3	350-0548	1	Resistor, Composition (10,000-Ohm, 1/2 Watt, 10%)
C3	356-0040	1	Capacitor, Electrolytic (10 Mfd, 20 Volt)	R4	303-0169	1	Potentiometer (3.5 Meg Ohm, 1/4 Watt, 30%)
C4	356-0030	1	Capacitor, Electrolytic (1 Mfd, 35 Volt)	R5	350-0572	1	Resistor, Composition (1-Meg Ohm, 1/2 Watt, 10%)
C5	355-0005	1	Capacitor, Plastic Dielectric (.22 Mfd, 200 VDC, 10%)	R6	350-0552	1	Resistor, Composition (22,000-Ohm, 1/2 Watt, 10%)
CR1	359-0027	1	Diode, Zener (1 Watt, 7.5 Volt, 5%)	R7	350-0536	1	Resistor, Composition (1000-Ohm, 1/2 Watt, 10%)
CR2	357-0004	1	Diode, Rectifier (400 MA, 400 Volt)	R8	350-0505	1	Resistor, Composition (2.7-Ohm, 1/2 Watt, 10%)
CR3	357-0004	1	Diode, Rectifier (400 MA, 400 Volt)	R9	350-0517	1	Resistor, Composition (27-Ohm, 1/2 Watt, 10%)
CR4	357-0004	1	Diode, Rectifier (400 MA, 400 Volt)	R10	303-0169	1	Potentiometer (3.5-Meg Ohm, 1/4 Watt, 30%)
CR5	357-0004	1	Diode, Rectifier (400 MA, 400 Volt)	R11	350-0584	1	Resistor, Composition (10-Meg Ohm, 1/2 Watt, 10%)
CR6	364-0017	1	Diode, Rectifier (8 Amp, 30 Volt)	R12	350-0529	1	Resistor, Composition (270-Ohm, 1/2 Watt, 10%)
CR7	357-0004	1	Diode, Rectifier (400 MA, 400 Volt)	R13	350-0529	1	Resistor, Composition (270-Ohm, 1/2 Watt, 10%)
K1	307-1039	1	Relay, Armature (12 Volt)	R14	350-0529	1	Resistor, Composition (270-Ohm, 1/2 Watt, 10%)
Q1	361-0003	1	Transistor	R15	350-0540	1	Resistor, Composition (2200-Ohm, 1/2 Watt, 10%)
Q2	362-0025	1	Transistor	R16	350-0540	1	Resistor, Composition (2200-Ohm, 1/2 Watt, 10%)
Q3	362-0025	1	Transistor	R17	350-1128	1	Resistor, Composition (220-Ohm, 2 Watt, 10%)
Q4	361-0003	1	Transistor	TB1	332-1246	1	Printed Wiring Board
Q5	362-0025	1	Transistor				
Q6	362-0025	1	Transistor				
Q7	362-0008	1	Transistor				
Q8	362-0008	1	Transistor				

ENGINE CONTROL MONITOR GROUP - 12 VOLT OPTIONAL (5 Fault Lights)

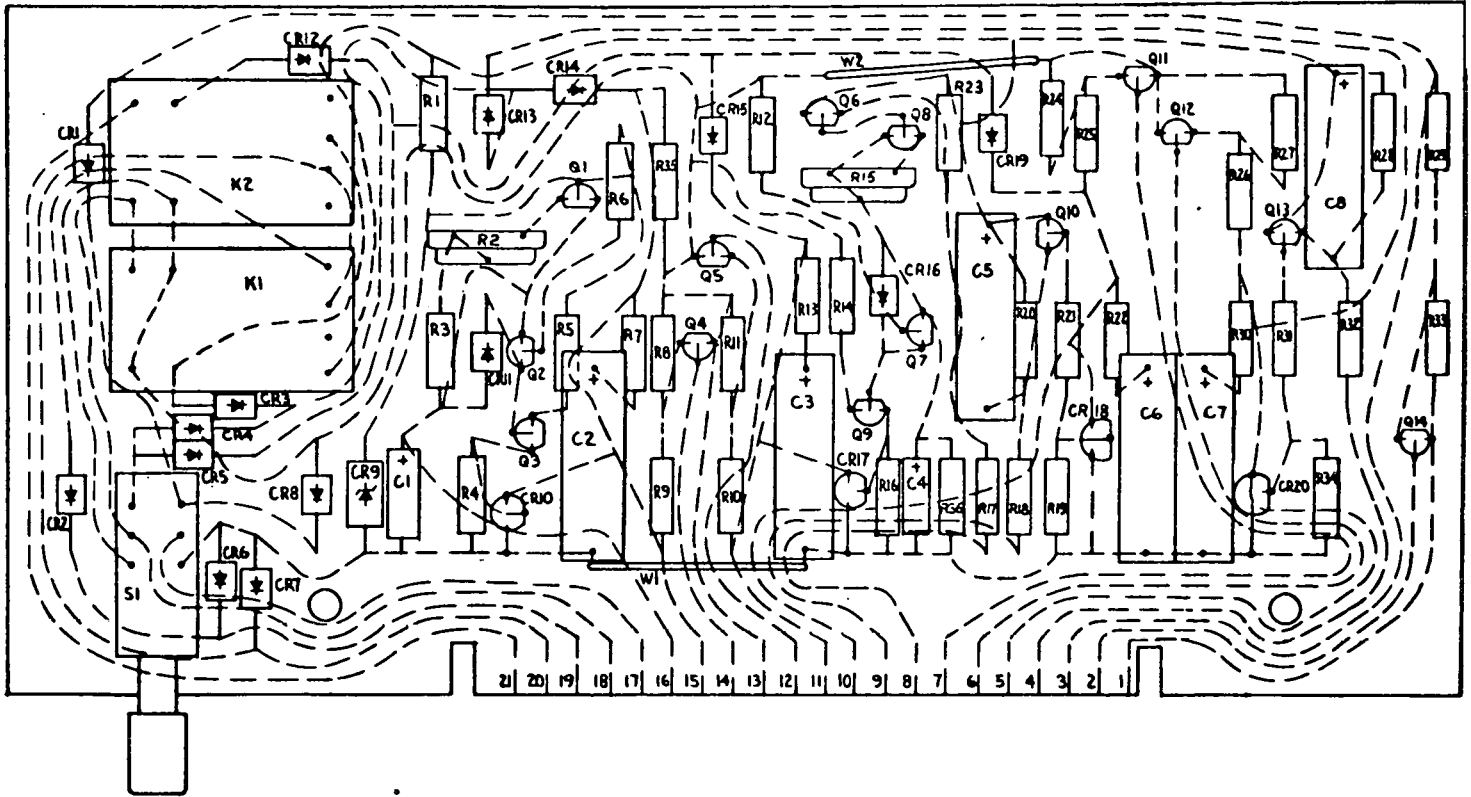

REF. NO.	PART NO.	QTY. USED	PART DESCRIPTION	REF. NO.	PART NO.	QTY. USED	PART DESCRIPTION
	300-0681		Monitor, Engine Control - 12 Volt - Optional	CR12	357-0004	1	Diode, Rectifier (400 MA, 400 Volt)
C1	356-0040	1	Capacitor, Electrolytic (10 Mfd, 20 Volt)	CR13	357-0004	1	Diode, Rectifier (400 MA, 400 Volt)
C2	355-0005	1	Capacitor, Plastic Dielectric (.22 Mfd, 200 VDC, 10%)	CR14	357-0004	1	Diode, Rectifier (400 MA, 400 Volt)
C3	355-0005	1	Capacitor, Plastic Dielectric (.22 Mfd, 200 VDC, 10%)	CR15	357-0004	1	Diode, Rectifier (400 MA, 400 Volt)
C4	356-0030	1	Capacitor, Electrolytic (1 Mfd, 35 Volt)	CR16	357-0004	1	Diode, Rectifier (400 MA, 400 Volt)
C5	355-0005	1	Capacitor, Plastic Dielectric (.22 Mfd, 200 VDC, 10%)	CR17	364-0017	1	Diode, Rectifier (8 Amp, 30 Volt)
C6	355-0005	1	Capacitor, Plastic Dielectric (.22 Mfd, 200 VDC, 10%)	CR18	364-0017	1	Diode, Rectifier (8 Amp, 30 Volt)
C7	355-0005	1	Capacitor, Plastic Dielectric (.22 Mfd, 200 VDC, 10%)	CR19	357-0004	1	Diode, Rectifier (400 MA, 400 Volt)
C8	355-0005	1	Capacitor, Plastic Dielectric (.22 Mfd, 200 VDC, 10%)	CR20	364-0017	1	Diode, Rectifier (8 Amp, 30 Volt)
CR1	357-0004	1	Diode, Rectifier (400 MA, 400 Volt)	CR21	357-0004	1	Diode, Rectifier (400 MA, 400 Volt)
CR2	357-0004	1	Diode, Rectifier (400 MA, 400 Volt)	K1	307-1039	1	Relay, Armature (12 Volt)
CR3	357-0004	1	Diode, Rectifier (400 MA, 400 Volt)	K2	307-1039	1	Relay, Armature (12 Volt)
CR4	357-0004	1	Diode, Rectifier (400 MA, 400 Volt)	Q1	362-0025	1	Transistor
CR5	357-0004	1	Diode, Rectifier (400 MA, 400 Volt)	Q2	362-0025	1	Transistor
CR6	357-0004	1	Diode, Rectifier (400 MA, 400 Volt)	Q3	361-0003	1	Transistor
CR7	357-0004	1	Diode, Rectifier (400 MA, 400 Volt)	Q4	362-0008	1	Transistor
CR8	357-0004	1	Diode, Rectifier (400 MA, 400 Volt)	Q5	362-0008	1	Transistor
CR9	359-0027	1	Diode, Zener (1 Watt, 7.5 Volt, 5%)	Q6	362-0008	1	Transistor
CR10	364-0017	1	Diode, Rectifier (8 Amp, 30 Volt)	Q7	362-0031	1	Transistor
CR11	357-0004	1	Diode, Rectifier (400 MA, 400 Volt)	Q8	362-0031	1	Transistor
				Q9	361-0003	1	Transistor
				Q10	362-0008	1	Transistor
				Q11	362-0008	1	Transistor
				Q12	362-0008	1	Transistor
				Q13	362-0008	1	Transistor
				Q14	362-0008	1	Transistor
				R1	350-0526	1	Resistor, Composition (100-Ohm, 1/2 Watt, 10%)
				R2	303-0169	1	Potentiometer (3.5 Megohm, 1/4 Watt, 30%)
				R3	350-0572	1	Resistor, Composition (1 Megohm, 1/2 Watt, 10%)

ENGINE CONTROL MONITOR GROUP - 12 VOLT OPTIONAL (5 Fault Lights)

REF. NO.	PART NO.	QTY. USED	PART DESCRIPTION	REF. NO.	PART NO.	QTY. USED	PART DESCRIPTION
R4	350-0517	1	Resistor, Composition (27-Ohm, 1/2 Watt, 10%)	R21	350-0529	1	Resistor, Composition (270-Ohm, 1/2 Watt, 10%)
R5	350-0536	1	Resistor, Composition (1000-Ohm, 1/2 Watt, 10%)	R22	350-0505	1	Resistor, Composition (2.7-Ohm, 1/2 Watt, 10%)
R6	350-0548	1	Resistor, Composition (10,000-Ohm, 1/2 Watt, 10%)	R23	350-0529	1	Resistor, Composition (270-Ohm, 1/2 Watt, 10%)
R7	350-0505	1	Resistor, Composition (2.7-Ohm, 1/2 Watt, 10%)	R24	350-0529	1	Resistor, Composition (270-Ohm, 1/2 Watt, 10%)
R8	350-0529	1	Resistor, Composition (270-Ohm, 1/2 Watt, 10%)	R25	350-0540	1	Resistor, Composition (2200-Ohm, 1/2 Watt, 10%)
R9	350-0540	1	Resistor, Composition (2200-Ohm, 1/2 Watt, 10%)	R21	350-0380	1	Resistor, Composition (510-Ohm, 1/2 Watt, 5%)
R10	350-0380	1	Resistor, Composition (510-Ohm, 1/2 Watt, 5%)	R27	350-0529	1	Resistor, Composition (270-Ohm, 1/2 Watt, 10%)
R11	350-0529	1	Resistor, Composition (270-Ohm, 1/2 Watt, 10%)	R28	350-0529	1	Resistor, Composition (270-Ohm, 1/2 Watt, 10%)
R12	350-0552	1	Resistor, Composition (22,000-Ohm, 1/2 Watt, 10%)	R29	350-0540	1	Resistor, Composition (2200-Ohm, 1/2 Watt, 10%)
R13	350-0505	1	Resistor, Composition (2.7-Ohm, 1/2 Watt, 10%)	R30	350-0505	1	Resistor, Composition (2.7-Ohm, 1/2 Watt, 10%)
R14	350-0536	1	Resistor, Composition (1000-Ohm, 1/2 Watt, 10%)	R31	350-0529	1	Resistor, Composition (270-Ohm, 1/2 Watt, 10%)
R15	303-0169	1	Potentiometer (3.5 Megohm, 1/4 Watt, 30%)	R32	350-0540	1	Resistor, Composition (2200-Ohm, 1/2 Watt, 10%)
R16	350-0517	1	Resistor, Composition (27-Ohm, 1/2 Watt, 10%)	R33	350-0529	1	Resistor, Composition (270-Ohm, 1/2 Watt, 10%)
R17	350-0540	1	Resistor, Composition (2200-Ohm, 1/2 Watt, 10%)	R34	350-0517	1	Resistor, Composition (27-Ohm, 1/2 Watt, 10%)
R18	350-0540	1	Resistor, Composition (2200-Ohm, 1/2 Watt, 10%)	R35	350-1128	1	Resistor, Composition (220-Ohm, 2 Watt, 10%)
R19	350-0517	1	Resistor, Composition (27-Ohm, 1/2 Watt, 10%)	R36	350-0584	1	Resistor, Composition (10 Megohm, 1/2 Watt, 10%)
R20	350-0529	1	Resistor, Composition (270-Ohm, 1/2 Watt, 10%)	S1	308-0280	1	Switch, Push - DPDT (1A, 28 VDC/.45A, 115 VAC)
				TB1	332-1231	1	Printed Wiring Board

SPECIAL PARTS LIST

FOR EK AND EM SERIES PENNSYLVANIA APPROVED GENERATING SETS

Refer first to this list for Pennsylvania Approved sets. Parts not in this list refer to the main parts list (Key 1 for EK and Key 2 for EM). When referring to the main parts list, reference to Spec letter or voltage also applies to these sets.

These sets are recognized by the numbers 30 (Gasoline Fuel), 31 (Gaseous Fuel), or 131 (Liquid Petroleum Fuel) appearing in the model. These numbers may appear just before or after the diagonal line (/). The number appearing after the diagonal line signifies a standard Pennsylvania Approved set (Example: 45.0EM15R31/1E).

GAS AND GAS-GASOLINE FUEL SYSTEM GROUP

REF. NO.	PART NO.	QTY. USED	PART DESCRIPTION
20	149-0752	1	Strainer, Fuel (1")
21	307-0836	1	Valve, Solenoid (1" - 12 Volt)
22	503-0273	1	Line, Fuel - Flexible (1" x 12")

CONTROL GROUP (AC OUTPUT PORTION)

REF. NO.	PART NO.	QTY. USED	PART DESCRIPTION
	320-0307	1	Lock, Circuit Breaker Handle

CONTROL GROUP (ENGINE INSTRUMENTS PORTION)

REF. NO.	PART NO.	QTY. USED	PART DESCRIPTION
3	SWITCH, SELECTOR		
	308-0138	1	Spec A through D
	308-0327	1	Begin Spec E
18	300-0730	1	Monitor, Engine Control (See Separate Group for Components)

ENGINE CONTROL MONITOR GROUP - 12 VOLT PENN STATE (1 Fault Light)

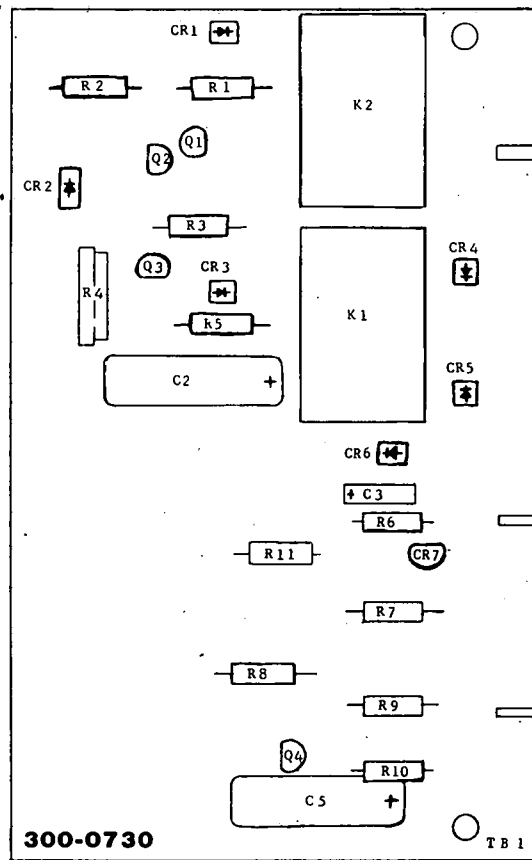

REF. NO.	PART NO.	QTY. USED	PART DESCRIPTION	REF. NO.	PART NO.	QTY. USED	PART DESCRIPTION
	300-0730		Monitor, Engine Control - 12 Volt (Penn State)	Q2	362-0025	1	Transistor
C1			Not used	Q3	362-0025	1	Transistor
C2	355-0005	1	Capacitor, Plastic Dielectric (.22 Mfd, 200 VDC, 10%)	Q4	362-0008	1	Transistor
C3	356-0040	1	Capacitor, Electrolytic (10 Mfd, 20 Volt)	R1	350-0536	1	Resistor, Composition (1000-Ohm, 1/2 Watt, 10%)
C4			Not used	R2	350-0526	1	Resistor, Composition (100-Ohm, 1/2 Watt, 10%)
C5	355-0005	1	Capacitor, Plastic Dielectric (.22 Mfd, 200 VDC, 10%)	R3	350-0552	1	Resistor, Composition (22,000-Ohm, 1/2 Watt, 10%)
CR1	357-0004	1	Diode, Rectifier (400 MA, 400 Volt)	R4	303-0169	1	Potentiometer (3.5 Megohm, 1/4 Watt, 30%)
CR2	359-0027	1	Diode, Zener (1 Watt, 7.5 Volt, 5%)	R5	350-0572	1	Resistor, Composition (1 Megohm, 1/2 Watt, 10%)
CR3	357-0004	1	Diode, Rectifier (400 MA, 400 Volt)	R6	350-0505	1	Resistor, Composition (2.7-Ohm, 1/2 Watt, 10%)
CR4	357-0004	1	Diode, Rectifier (400 MA, 400 Volt)	R7	350-0517	1	Resistor, Composition (27-Ohm, 1/2 Watt, 10%)
CR5	357-0004	1	Diode, Rectifier (400 MA, 400 Volt)	R8	350-0529	1	Resistor, Composition (270-Ohm, 1/2 Watt, 10%)
CR6	357-0004	1	Diode, Rectifier (400 MA, 400 Volt)	R9	350-0529	1	Resistor, Composition (270-Ohm, 1/2 Watt, 10%)
CR7	364-0017	1	Diode, Rectifier (8 Amp, 30 Volt)	R10	350-0540	1	Resistor, Composition (2200-Ohm, 1/2 Watt, 10%)
K1	307-1039	1	Relay, Armature (12 Volt)	R11	350-0971	1	Resistor, Composition (220-Ohm, 2 Watt, 5%)
K2	307-1039	1	Relay, Armature (12 Volt)	TB1	332-1246	1	Printed Wiring Board
Q1	361-0003	1	Transistor				



**MANUFACTURER'S
LIMITED
WARRANTY**

Onan extends to the original purchaser of goods for use, the following warranty covering goods manufactured or supplied by Onan, subject to the qualifications indicated.

- (1) Onan warrants to original purchaser for the periods set forth below that goods manufactured or supplied by it will be free from defects in workmanship and material, provided such goods are installed, operated, and maintained in accordance with Onan's written instructions, and further provided, that installation inspection and initial start-up on commercial-industrial generator set or power system installations are conducted by an Onan Authorized Distributor or its designated service representative.

PRODUCT APPLICATION	PERIOD OF WARRANTY
<input type="checkbox"/> Goods used in personal, family and household applications.	One (1) year from date of purchase.
<input type="checkbox"/> Goods used in commercial-industrial applications.	One (1) year from date of purchase.
<input type="checkbox"/> Commercial-industrial stationary generator sets.	One (1) year from date of initial start-up.
<input type="checkbox"/> Commercial-industrial, standby power systems with nominal operating speeds of 1800 rpms or less which are installed in the U.S. or Canada (must include Onan supplied generator sets, automatic transfer switch, exerciser and running time meter).	* Five (5) years or 1500 hours, whichever occurs first from the date of initial start-up. Labor allowance for the first two (2) years or 1500 hours, whichever occurs first from the date of initial start-up.
<input type="checkbox"/> Commercial-industrial, standby power systems with nominal operating speeds of 1800 rpms or less which are installed outside the U.S. or Canada (must include Onan supplied generator set, automatic transfer switch, exerciser and running time meter).	* Two (2) years or 1500 hours, whichever occurs first from the date of initial start-up.
<input type="checkbox"/> Repair or replacement parts.	Ninety (90) days from date of purchase, excludes labor.

* Must be registered on Form No. 23C065, to be provided and completed by seller.

- (2) Onan's sole liability and Purchaser's sole remedy for a failure of goods to perform as warranted shall be limited to the repair or replacement of goods returned to Onan's factory at 1400 73rd Avenue N.E., Minneapolis, Minnesota 55432, or to an Onan Authorized Distributor or its designated service representative, transportation prepaid.

Except as indicated below, this warranty does not include travel time and mileage labor for removal of Onan product from its application and reinstallation.

a) Removal and Reinstallation

- i. *Garden Tractor Engines*—Onan will pay up to a maximum of two (2) hours labor for warranty work requiring removal and reinstallation of Onan industrial engines in garden tractor applications performed by an Onan Authorized Distributor or its designated service representative.
- ii. *Vehicles*—Onan will pay one (1) hour labor for warranty work requiring removal and reinstallation performed by an Onan Authorized Distributor or its designated service representative on vehicle applications utilizing a POWER DRAWER® and Onan supplied sliding tray generator set installations.

b) Travel Time and Mileage

- i. *Marine Generator Set Installations*—Onan will, for six (6) months after date of purchase, pay travel time up to four (4) hours and mileage costs up to one hundred fifty (150) miles related to warranty repairs, provided, such travel and repairs are performed by an Onan Authorized Distributor or its designated service representative.
- ii. *Commercial-Industrial Standby Generator Set and System Installations*—Provided the generator set or system is permanently wired in a stationary installation, Onan will, for six (6) months after initial start-up, pay travel time up to four (4) hours and mileage costs up to one hundred fifty (150) miles for warranty repairs performed by an Onan Authorized Distributor or its designated service representative.

(3) THERE IS NO OTHER EXPRESS WARRANTY.

IMPLIED WARRANTIES INCLUDING MERCHANTABILITY AND FITNESS FOR A PARTICULAR PURPOSE, ARE LIMITED TO PERIODS OF WARRANTY SET FORTH ABOVE AND TO THE EXTENT PERMITTED BY LAW, ANY AND ALL IMPLIED WARRANTIES ARE EXCLUDED.

IN NO EVENT IS ONAN LIABLE FOR INCIDENTAL OR CONSEQUENTIAL DAMAGES.

(4) All claims must be brought to the attention of Onan or an Onan Authorized Distributor or its designated service representative within thirty (30) days after discovery that goods or parts fail to perform as warranted.

(5) THIS WARRANTY SHALL NOT APPLY TO:

- a) Cost of maintenance, adjustments, installation and start-up.
- b) Failures due to normal wear, accident, misuse, abuse, negligence or improper installation.
- c) Products which are altered or modified in manner not authorized by manufacturer in writing.
- d) Failure of goods caused by defects in the system or application in which the goods are installed.
- e) Telephone, telegraph, teletype or other communication expenses.
- f) Living and travel expenses of persons performing service, except as specifically included in Section 2.
- g) Rental equipment used while warranty repairs are being performed.
- h) Overtime labor requested by purchaser.
- i) Starting batteries.

(6) No person is authorized to give any other warranties or to assume any other liabilities on Onan's behalf, unless made or assumed in writing by an officer of Onan, and no person is authorized to give any warranties or assume any other liability on behalf of Seller unless made or assumed in writing by Seller.

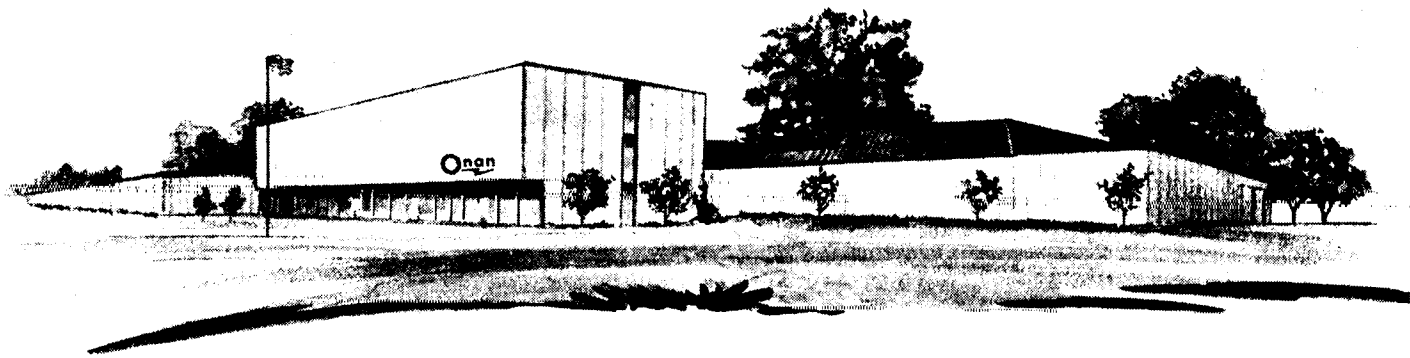

ONAN 1400 73RD AVENUE N.E. • MINNEAPOLIS, MINNESOTA 55432
A DIVISION OF ONAN CORPORATION

