

**Onan**

***Engine***

**Operator's Manual**

**P216, P218  
P220, P224**

**Performer Series**

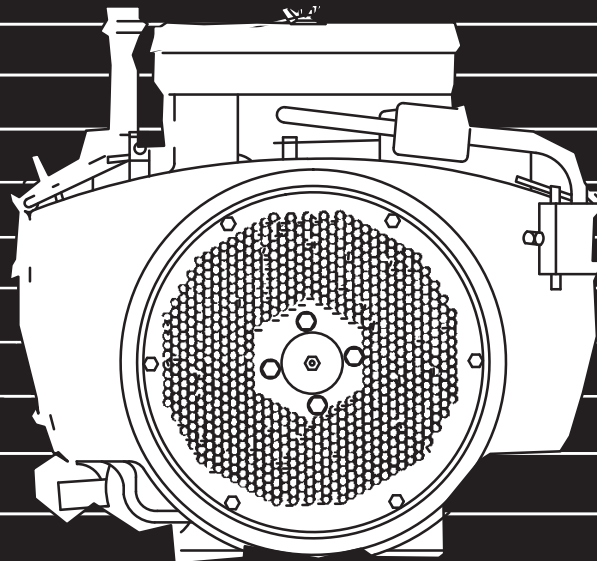

**Supplement: 965-1077**

**Date: 02-02**

**To Be Insert In—**

Manual 965-0182B, dated 01-01

---

***Purpose:*** This supplement transmits updated engine oil recommendations on Page 4 and the revised Periodic Maintenance Schedule on Page 9 of Manual 965-0182B dated 01-01. Insert this Supplement and attachments under the front cover.

***Attachments:*** Attached are two sheets, one printed with Pages 3 and 4 back to back and the other with Pages 9 and 10 back to back for replacement of the respective manual sheets by the customer.

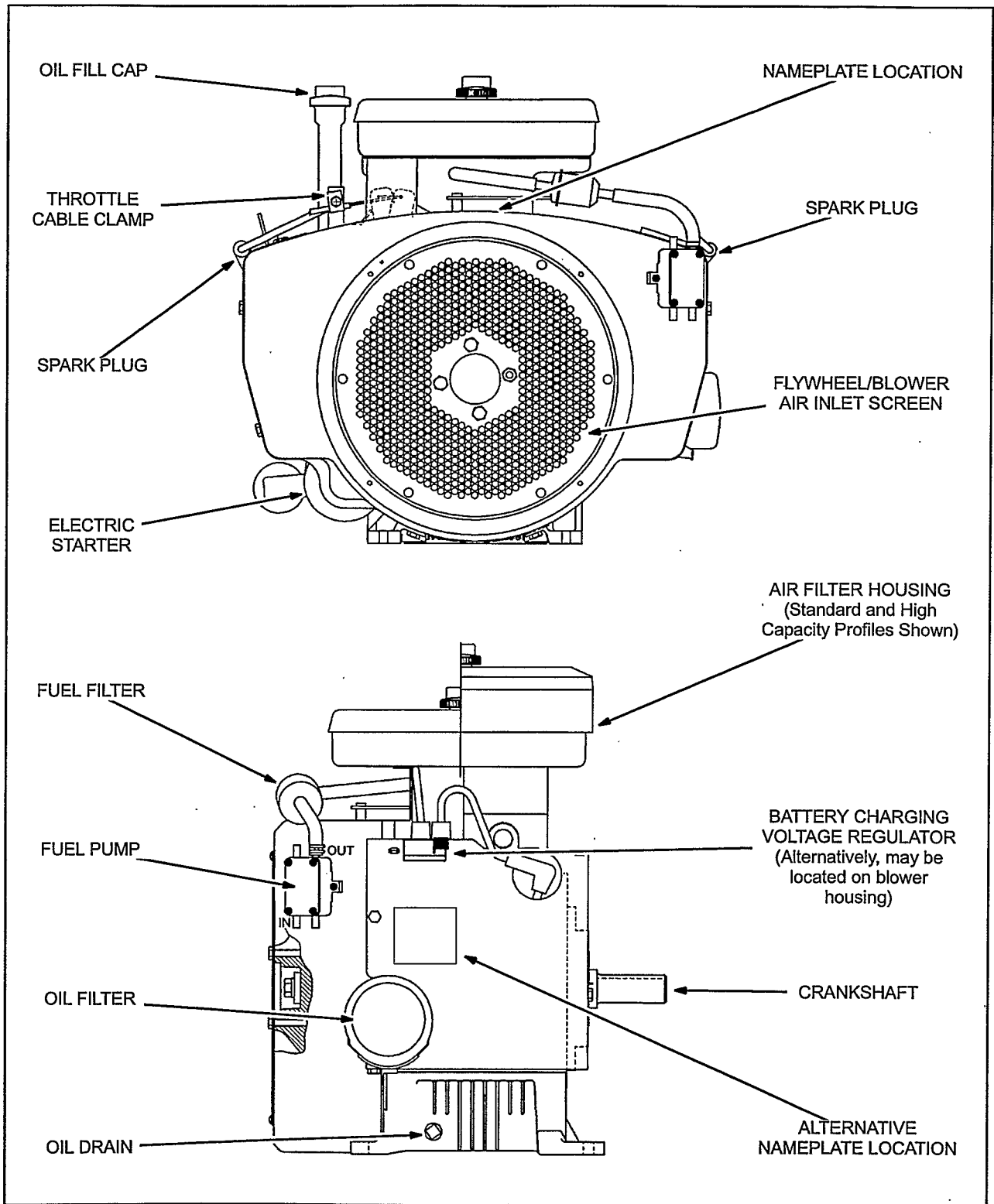

FIGURE 2. TYPICAL ENGINE CONFIGURATION

## FUEL RECOMMENDATIONS

**⚠ WARNING** *Gasoline and LPG are highly flammable fuels and can cause severe personal injury or death. Do not smoke if you smell gas or gasoline or are near fuel tanks or fuel-burning equipment or are in an area sharing ventilation with such equipment. Keep flames, sparks, pilot lights, electrical arcs, switches, arc-producing equipment and all other sources of ignition well away. Keep a type ABC fire extinguisher nearby.*

### Gasoline Models

Use clean, fresh unleaded gasoline having a minimum octane rating (Anti-Knock Index) of 87.

During some times of the year only mandated "oxygenated" gasolines may be available. These are acceptable for use, but not preferable. Leaded gasoline may be used but will result in the extra maintenance required for removing combustion chamber and spark plug deposits. Do not use gasoline or gasoline additives (de-icers) containing methanol because methanol can be corrosive to fuel system components.

**⚠ CAUTION** *Do not use gasoline or gasoline additives containing methanol because methanol can be corrosive to fuel system components.*

*Avoid using highly leaded gasolines and lead additives because of the extra engine maintenance that will be required.*

### LPG Models

Use clean, fresh HD-5 grade liquified petroleum gas (LPG) or equivalent product consisting of at least 90

percent propane. Commercial LPG may contain more than 2.5 percent butane which can result in poor fuel vaporization and poor engine starting in low ambient temperatures (below 32° F (0° C)).

### Natural Gas Models

Use commercially available natural gas fuel.

## ENGINE OIL RECOMMENDATIONS

Use API (American Petroleum Institute) performance Class **SJ**, **SH** or **SG** engine oil, which may be in combination with performance Class CH-4, CG-4 or CF-4 (for example: SJ/CH-4). Also look for the SAE (Society of Automotive Engineers) viscosity grade. Referring to Table 1, choose the viscosity grade appropriate for the ambient temperatures expected until the next scheduled oil change.

Single-grade SAE 30 oil is preferable when temperatures are consistently above freezing. Multigrade oils are better when wide temperature variations are expected.

TABLE 1. OIL VISCOSITY VS. TEMPERATURE

EXPECTED AMBIENT TEMPERATURES	SAE VISCOSITY GRADE
32° F (0° C) and higher	30
10° F to 100° F (-12° C to 38° C)	15W-40 (OnaMax)
0° F to 80° F (-18° C to 27° C)	10W-30 10W-40
-20° F to 50° F (-28° C to 10° C)	5W-30

# Periodic Maintenance

Periodic maintenance is essential for top engine performance. Use Table 2 as a guide for normal periodic maintenance. Under hot or dusty operating conditions some maintenance operations should be performed more frequently, as indicated by the footnotes in the table. Keep a log of maintenance performed and the hours run. Recording maintenance

will help you keep it regular and provide a basis for supporting warranty claims.

Maintenance, replacement or repair of emission control devices and systems may be performed by any engine repair establishment or individual. However, warranty work must be completed by an authorized Onan dealer or distributor.

**TABLE 2. PERIODIC ENGINE MAINTENANCE SCHEDULE**

MAINTENANCE OPERATION	MAINTENANCE FREQUENCY						
	Break-in		Every Day or Every 8 Hours	Every 50 Hours	Every Month	Every 150 Hours	Every 450 Hours
	After First 24 Hours	After First 50 Hours					
Inspect Engine			x <sup>1</sup>				
Check Oil Level			x				
Clean Air Cleaner Foam Wrapper				x <sup>2</sup>			
Clean Cylinder Cooling Fins				x <sup>2</sup>			
Check Starting Battery					x <sup>4</sup>		
Change Engine Oil—Standard (Low Profile) Base	x			x <sup>2, 3</sup>			
Change Engine Oil—Medium and High Capacity Bases	x					x <sup>2, 3</sup>	
Change Engine Oil Filter	x					x <sup>2, 3</sup>	
Replace Fuel Filter (if so equipped)							x
Replace Air Cleaner Element						x <sup>2</sup>	
Replace Spark Plugs							x
Adjust Engine Valve Clearance (Model P224 only)		x <sup>5</sup>					x <sup>5</sup>
Adjust Engine Valve Clearance (Models P216, P218 and P220)							x <sup>5</sup>
Clean Cylinder Heads of Deposits							x <sup>5, 6</sup>

1. Check for oil, fuel and exhaust leaks, loose parts and unusual noises and vibrations.
2. Perform more often when operating in dusty conditions.
3. Perform more often when operating in hot conditions.
4. See instructions for battery care provided by the equipment or battery manufacturer.
5. Must be performed by a qualified mechanic according to the engine Service Manual.
6. Clean more often when using leaded fuel or running the engine continuously under light load. Onan 4C carburetor and combustion cleaner is recommended every 200 hours of operation.

## DAILY (8 HOUR) MAINTENANCE

The operator should check the following before the first start of the day and after every eight hours of operation:

1. Inspect fuel lines and fittings for leaks. Repair leaks immediately.
2. Look and listen for exhaust system leaks while the engine is running. Look for cracks and severe rusting in the muffler and tailpipe. Have all leaks repaired before continuing to operate the equipment.

**▲WARNING** *Hot exhaust parts can cause severe burns. Allow the engine time to cool before servicing the exhaust system.*

3. Check the engine for dirt and debris and clean the flywheel air inlet screen and cylinder cooling fins as necessary.

**▲CAUTION** *A clogged flywheel air inlet screen or dirty cooling fins can cause overheating and engine damage. Keep the cooling fins and air inlet screen clean.*

4. Check the engine oil level. The equipment must be parked on a level surface and the engine stopped. To get an accurate reading, wait a minute or so to allow the oil to settle in the crankcase if the engine has been running.

**▲WARNING** *Crankcase pressure can blow hot engine oil out the fill tube causing severe burns. Always stop the engine before removing the oil fill cap.*

Turn the oil fill cap (Figure 3) counterclockwise and then lift it from the fill tube. Wipe the dipstick clean and push it back into the oil fill tube until the cap seats and then withdraw it to check the oil level.

If the oil level is low, add API Class SG or SH oil (also SG/CD, SG/CE, SH/CD or SH/CE) having

an SAE viscosity grade appropriate for the expected temperatures, as indicated by Table 1.

DO NOT FILL TO A LEVEL ABOVE THE FULL MARK ON THE DIPSTICK. Drain the excess oil if too much has been added.

**▲CAUTION** *Too much oil can cause high oil consumption, high operating temperatures and oil foaming. Too little oil can cause severe engine damage. Keep the oil level between the Full and Add marks on the dipstick.*

Reinstall the dipstick and cap after checking or adding oil, turning it clockwise until it is secure.

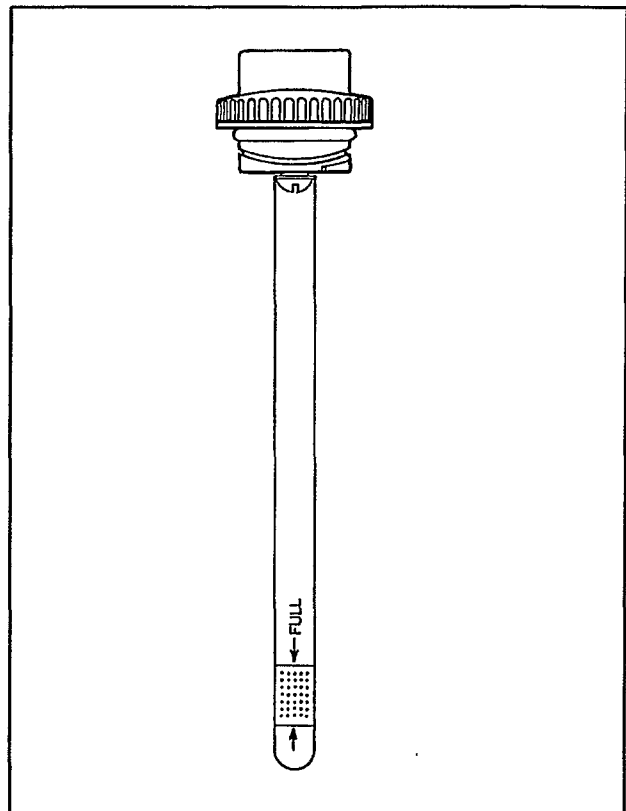

FIGURE 3. OIL FILL CAP AND DIPSTICK

---

# Safety Precautions

---

Thoroughly read the OPERATOR'S MANUAL before operating the engine. Safe operation and top performance can be obtained only with proper operation and maintenance.

The following symbols in this Manual alert you to potential hazards to the operator, service person and equipment.

**⚠ DANGER** Alerts you to an immediate hazard which will result in severe personal injury or death.

**⚠ WARNING** Alerts you to a hazard or unsafe practice which can result in severe personal injury or death.

**⚠ CAUTION** Alerts you to a hazard or unsafe practice which can result in personal injury or equipment damage.

Electricity, fuel, exhaust, moving parts and batteries present hazards which can result in severe personal injury or death.

## GENERAL PRECAUTIONS

- Keep ABC fire extinguishers handy.
- Make sure all fasteners are secure and torqued properly.
- Keep the engine and its compartment clean. Excess oil and oily rags can catch fire. Dirt and gear stowed in the compartment can restrict cooling air.
- Before working on the engine, disconnect the negative (–) battery cable at the battery to prevent starting.
- Use caution when making adjustments while the engine is running—hot, moving or electrically live parts can cause severe personal injury or death.
- Used engine oil has been identified by some state and federal agencies as causing cancer or reproductive toxicity. Do not ingest, inhale, or contact used oil or its vapors.
- Benzene and lead in some gasolines have been identified by some state and federal agencies as causing cancer or reproductive toxicity. Do not ingest, inhale or contact gasoline or its vapors.
- Do not work on the engine when mentally or physically fatigued or after consuming alcohol or drugs.
- Carefully follow all applicable local, state and federal codes.

- **⚠ WARNING** *This engine is not designed or intended for use in aircraft. Such use can lead to engine failure, severe personal injury or death.*

## FUEL IS FLAMMABLE AND EXPLOSIVE

- Keep flames, cigarettes, sparks, pilot lights, electrical arc-producing equipment and switches and all other sources of ignition well away from areas where fuel fumes are present and areas sharing ventilation.
- DO NOT fill the fuel tank while the engine is running.
- Fuel lines must be copper or steel tubing or piping, adequately secured and free of leaks.
- Use approved flexible fuel hose for connections at the engine. Do not use copper tubing as a flexible connector—vibration will cause it to work-harden and break. Use non-conductive hose if the fuel line could become a path for cranking current.
- The fuel line must have a manual shutoff valve unless the highest fuel level in the supply tank is lower than the connection at the engine.

## ENGINE EXHAUST IS DEADLY!

- Learn the symptoms of carbon monoxide poisoning in this Manual.
- Inspect the exhaust system every time the engine is started and after every eight hours of operation. If the exhaust noise changes, shut down the engine immediately and have it inspected.
- DO NOT use engine cooling air to heat a room.
- Make sure there is ample fresh air when operating the engine in a confined area.

## MOVING PARTS CAN CAUSE SEVERE PERSONAL INJURY OR DEATH

- Do not wear loose clothing or jewelry near moving parts such as PTO shafts, fans, belts and pulleys.
- Keep hands away from moving parts.
- Keep guards in place over fans, belts, pulleys, etc.

## BATTERY GAS IS EXPLOSIVE

- WEAR SAFETY GLASSES and DO NOT SMOKE while servicing batteries.
- When disconnecting or reconnecting battery cables, always disconnect the negative (–) battery cable first and reconnect it last to reduce arcing.

---

# Table of Contents

---

TITLE .....	PAGE
<b>SAFETY PRECAUTIONS</b> .....	Inside Front Cover
<b>INTRODUCTION</b> .....	2
About This Manual .....	2
Nameplate .....	2
Fuel Recommendations .....	4
Engine Oil Recommendations .....	4
Starting Batteries .....	5
Exhaust System .....	5
<b>OPERATION</b> .....	6
Pre-Start Checks .....	6
Starting .....	6
Engine Break-In .....	7
Operation In Dusty Conditions .....	7
Operation In Hot Weather .....	7
Operation In Cold Weather .....	7
Out-of-Service Protection .....	8
Returning The Engine To Service .....	8
<b>PERIODIC MAINTENANCE</b> .....	9
Daily (8 Hour) Maintenance .....	10
Engine Oil And Filter Change .....	11
Air Cleaner Maintenance .....	12
Cooling System Maintenance .....	13
Fuel Filter Replacement .....	13
Spark Plug Replacement .....	13
<b>ADJUSTMENTS</b> .....	14
Carburetor Adjustments .....	14
Reconnecting The Choke Cable .....	14
Engine Speed Adjustments .....	15
<b>TROUBLESHOOTING</b> .....	16
<b>SPECIFICATIONS</b> .....	17
<b>INFORMATION FOR CALIFORNIA ENGINE USERS</b> .....	18

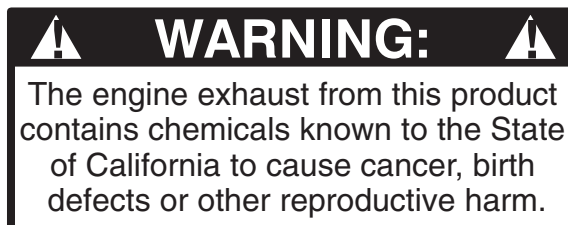



---

# Introduction

---

## ABOUT THIS MANUAL

This manual covers the operation and maintenance of the horizontal-shaft Performer Series of engines. Each operator of the power equipment should study this engine manual carefully and observe all of its instructions and precautions. Proper use and periodic maintenance are responsibilities of the operator(s) and are essential for top performance.

**⚠WARNING** *Unauthorized modifications or replacement of fuel, exhaust, air intake or speed control system components that affect engine emissions are prohibited by law in the State of California.*

**⚠WARNING** *LPG (liquified petroleum gas) is flammable and explosive and can cause asphyxiation. NFPA 58, Section 1.6 requires all persons handling LPG to be trained in proper handling and operating procedures.*

**⚠WARNING** *Improper service or parts replacement can lead to severe personal injury or death and to damage to equipment and property. Service personnel must be qualified to perform electrical and mechanical service.*

## NAMEPLATE

**Model and Serial Numbers:** Whenever contacting an Onan dealer or distributor for information, parts or service, always provide the model number and the serial number marked on the nameplate of the engine. (The serial number is in the row marked “S/N”, just below the model number.) Figure 1 illustrates a typical engine nameplate and Figure 2 the location of the nameplate on the engine.

Genuine Onan replacement parts obtained from an Onan dealer or distributor are recommended.

**Federal Emissions Compliance Period:** The Federal Emissions Compliance Period referred to on the nameplate indicates the number of operating hours for which the engine has been shown to meet Federal emissions requirements.

For engines of less than 225 cc displacement, Category C = 125 hrs, B = 250 hrs, A = 500 hrs. For engines of 225 cc and greater displacement, Category C = 250 hrs, B = 500 hrs, A = 1000 hrs.

IMPORTANT ENGINE INFORMATION	
	ONAN CORPORATION 1400 73rd Ave. NE Minneapolis, MN 55432 Made in Canada
Engine Model:	
S/N:	
<i>[The engine family designation, engine displacement, statement of compliance with the applicable EPA and / or California emissions regulations, including the compliance period or category, appear in this block on the actual nameplate on the engine.]</i>	

FIGURE 1. TYPICAL ENGINE NAMEPLATE

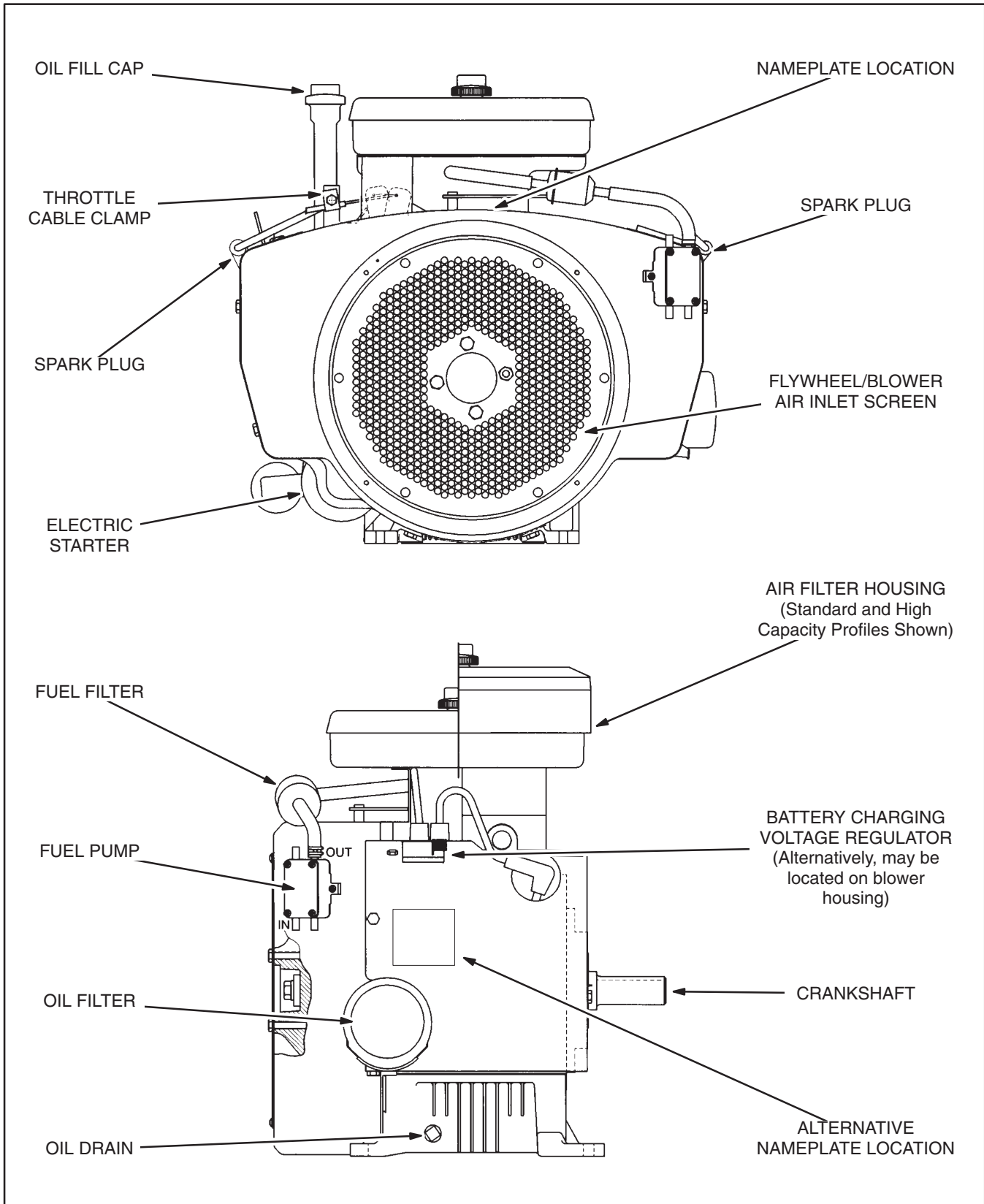

**FIGURE 2. TYPICAL ENGINE CONFIGURATION**

## FUEL RECOMMENDATIONS

**⚠ WARNING** *Gasoline and LPG are highly flammable fuels and can cause severe personal injury or death. Do not smoke if you smell gas or gasoline or are near fuel tanks or fuel-burning equipment or are in an area sharing ventilation with such equipment. Keep flames, sparks, pilot lights, electrical arcs and arc-producing equipment and all other sources of ignition well away. Keep a type ABC fire extinguisher nearby.*

### Gasoline Models

Use clean, fresh unleaded gasoline having a minimum octane rating (Anti-Knock Index) of 87.

During some times of the year only mandated “oxygenated” gasolines may be available. These are acceptable for use, but not preferable. Leaded gasoline may be used but will result in the extra maintenance required for removing combustion chamber and spark plug deposits. Do not use gasoline or gasoline additives (de-icers) containing methanol because methanol can be corrosive to fuel system components.

**⚠ CAUTION** *Do not use gasoline or gasoline additives containing methanol because methanol can be corrosive to fuel system components.*

*Avoid using highly leaded gasolines and lead additives because of the extra engine maintenance that will be required.*

### LPG Models

Use clean, fresh HD-5 grade liquified petroleum gas (LPG) or equivalent product consisting of at least 90

percent propane. Commercial LPG may contain more than 2.5 percent butane which can result in poor fuel vaporization and poor engine starting in low ambient temperatures (below 32° F (0° C)).

### Natural Gas Models

Use commercially available natural gas fuel.

## ENGINE OIL RECOMMENDATIONS

Use premium quality motor oil. Look for the API (American Petroleum Institute) classification and use Class SG or SH oil (also SG/CD, SG/CE, SH/CD or SH/CE). Also look for the SAE (Society of Automotive Engineers) viscosity grade. Referring to Table 1, choose the viscosity grade appropriate for the ambient temperatures expected during the period of time until the next scheduled oil change.

Single-grade SAE 30 oil is preferable when temperatures are consistently above freezing. Multigrade oils are better when wide temperature variations are expected.

TABLE 1. OIL VISCOSITY VS. TEMPERATURE

EXPECTED AMBIENT TEMPERATURES	SAE VISCOSITY GRADE
32° F (0° C) and higher	30
10° F to 100° F (-12° C to 38° C)	15W-40 (OnaMax)
0° F to 80° F (-18° C to 27° C)	10W-30 10W-40
-20° F to 50° F (-28° C to 10° C)	5W-30

---

## STARTING BATTERIES

The engine is equipped with a 12 volt electric starter. Prompt starting requires sufficient battery capacity and battery cable size. Neither cranking performance nor starter service life will be satisfactory with an undersized battery.

Regular, monthly maintenance of batteries may be required. See *Periodic Maintenance* and any instructions available from the equipment or battery manufacturer. It should be noted that as long as the equipment is operated regularly, the automatic battery recharging system on the engine should be able to maintain battery charge. See OUT-OF-SERVICE PROTECTION under *Operation* regarding battery care during storage for prolonged periods.

## EXHAUST SYSTEM

**EXHAUST GAS IS DEADLY!** Mobile engine-powered equipment must never be operated inside buildings or other enclosed spaces without ample fresh air ventilation.

Stationary engine-powered equipment installed inside buildings or other enclosed spaces must be equipped with a leak-free exhaust system that carries all exhaust gases to the outside, well away from all windows, doors, vents and other openings into the building or enclosure.

It is the responsibility of the equipment operator(s) to check for exhaust leaks on a daily basis and to have all leaks repaired before continuing to operate the equipment.

---

# Operation

---

**⚠WARNING** **EXHAUST GAS IS DEADLY!**

*Exhaust gases contain carbon monoxide, an odorless and colorless gas. Carbon monoxide is poisonous and can cause unconsciousness and death. Symptoms of carbon monoxide poisoning include:*

- *Dizziness*
- *Nausea*
- *Headache*
- *Weakness and Sleepiness*
- *Throbbing in Temples*
- *Muscular Twitching*
- *Vomiting*
- *Inability to Think Coherently*

**IF YOU OR ANYONE ELSE EXPERIENCE ANY OF THESE SYMPTOMS, GET OUT INTO THE FRESH AIR IMMEDIATELY. If symptoms persist, seek medical attention. Shut down the engine and do not operate it until it has been inspected and repaired.**

**Make certain the exhaust system is properly installed. Inspect it every time the engine is started and after every eight hours of continuous operation.**

## PRE-START CHECKS

Before the first start of the day and after every eight hours of operation perform the maintenance instructed in DAILY (8 HOUR) MAINTENANCE under *Periodic Maintenance*. Keep a log of maintenance and the hours run and perform any maintenance that may be due. Also, if the equipment has been in storage, return the engine to service as instructed under RETURNING THE ENGINE TO SERVICE in this section.

Always follow the equipment manufacturer's operating instructions and observe all precautions when operating power equipment.

**⚠WARNING** *Moving parts can cause severe personal injury or death. Hot exhaust parts can cause severe burns. Stay clear of hot or moving parts. Make sure all protective shields and guards are secure in place before starting up the equipment.*

## STARTING

1. Check the oil level if this is the first start of the day and add oil as necessary.

**⚠CAUTION** *Starting the engine without oil will cause severe engine damage. Always keep the engine oil level between the Full and Add marks on the dipstick.*

2. Fill the gasoline or LPG fuel tank, if necessary, and open any fuel shutoff valve; for example, the valve(s) at the LPG container(s).
3. Release the clutch if the engine is so equipped.
4. *If this is a gasoline engine with a manual choke, pull the choke knob out to its full-choke position. On equipment with a solenoid operated choke, push the switch to its choke position. In warm weather, however, or when the engine is warm, try starting without the choke.*
5. Push the throttle knob or lever to the middle of its speed range.
6. Turn the ignition-start switch to its start position and hold it there until the engine starts. Do not crank for more than 30 seconds at a time and wait at least one minute between tries when cranking. See *Troubleshooting* if the engine does not start after several tries.
7. *If this is a gasoline engine with a manual choke, keep your hand on the choke knob and slowly push it in to the full-open choke position, pulling back if necessary to keep the engine running smoothly. The colder the weather the longer it will take the engine to start running smoothly with the choke fully open. Do not operate the equipment until the engine has warmed up sufficiently to run smoothly with the choke fully open.*

---

## ENGINE BREAK-IN

Engine break-in as a result of proper care during the first hours of operation of a new or rebuilt engine results in the ideal fitting of all internal moving metal parts, which is essential for top engine performance. For controlled engine break-in:

1. Operate the equipment as it is intended to be operated. However, for the first 3 hours, if possible, operate the equipment at about half the available engine power, occasionally operating at full engine power for brief periods. Also, if possible, avoid prolonged low-speed, low-power operation during engine break-in.
2. Proper engine oil is especially critical during break-in because of the higher engine temperatures that can be expected. See **RECOMMENDED ENGINE OIL** in *Introduction*. Change the oil if it is not appropriate for the ambient temperatures during the break-in period. See Table 1.
3. Check the oil level twice a day or after every 4 hours of operation during the first 24 hours of operation.
4. Change the oil and oil filter after the first 24 hours of operation.
5. See Table 2 for engine models which require valve clearance adjustment after the first 50 hours of operation.

## OPERATION IN DUSTY CONDITIONS

1. Keep the engine cooling fins and flywheel air inlet screen clean.
2. Perform air cleaner maintenance more often than normal—as required. See Table 2.
3. Change the engine oil and oil filter more often than normal. See Table 2.

## OPERATION IN HOT WEATHER

Pay particular attention to the following items when operating the engine in temperatures above 100° F (38° C):

1. Keep the flywheel air inlet screen and cylinder cooling fins clean. See to it that nothing obstructs air flow to and from the engine.
2. Check the oil level more frequently.
3. Change the oil and oil filter more often than normal. See Table 2.
4. Make sure the engine oil viscosity is appropriate for the ambient temperatures and change the oil if necessary. See Table 1.

## OPERATION IN COLD WEATHER

Pay particular attention to the following items when operating the engine in temperatures below freezing:

1. Make sure the engine oil viscosity is appropriate for the ambient temperatures and change the oil if necessary. See Table 1. If the temperature drops before you have the chance to change the oil, warm up the engine by moving the equipment into a heated space before attempting to start the engine or change oil.

**⚠WARNING** ***EXHAUST GAS IS DEADLY!***  
***Never operate mobile engine-powered equipment indoors without ample fresh air ventilation.***

2. Use fresh gasoline and fill the fuel tank after each day's use to reduce problems with moisture condensation if this is a gasoline engine.
3. Keep the battery in a well-charged condition.
4. After each use push the equipment throttle knob or lever to the middle of its speed range so that if ice forms on the linkage during storage it will be easier to start the engine.

---

## OUT-OF-SERVICE PROTECTION

Protect an engine that will be out of service for more than 30 days as follows:

1. If the equipment will not be operated for more than 120 days, add a fuel preservative (Ona-Fresh™) to the equipment fuel tank (gasoline engines only). Follow the instructions on the container label. Then run the engine for about 10 minutes so that the fuel line and carburetor are filled with fuel that has preservative. *Unless a preservative (stabilizer) is added, the gasoline will deteriorate causing fuel system corrosion, gum formation and varnish-like deposits which can lead to hard starting and rough operation.*
- ⚠WARNING** *Gasoline preservatives (stabilizers) are toxic. Follow the instructions on the container label. Avoid skin contact. Wash your hands with soap and water after dispensing the fluid.*
2. Run the engine until it reaches normal operating temperature. Stop the engine and drain the oil from the engine while it is still warm. Refill with fresh oil and attach a tag stating the viscosity of the oil used.
  3. Remove the spark plugs and squirt 1 ounce (2 tablespoons or 28 grams) of rust inhibitor or SAE 30 oil into each cylinder. Crank the engine over a few times and reinstall the spark plugs.
  4. Perform air cleaner maintenance as instructed in *Periodic Maintenance*.

5. Clean the governor linkage and wrap it with a clean cloth for protection.
6. Plug the exhaust outlet to prevent moisture, dirt, bugs, etc. from entering.
7. Provide a suitable cover for the entire unit.
8. If so equipped, disconnect the battery (negative [-] cable first) and follow the battery or equipment manufacturer's storage instructions.

## RETURNING THE ENGINE TO SERVICE

1. Remove the cover and all protective wrapping and the plug from the exhaust outlet.
2. Check the tag on the oil base. Change the oil if the viscosity is not appropriate for the expected ambient temperatures. See Table 1.
3. Check the fuel filter and fuel lines to make sure they are secure and have no cracks or leaks.
4. Check to see that the choke, throttle and governor linkages move freely.
5. If so equipped, clean and check the battery according to the battery or equipment manufacturer's instructions and connect the battery cables (positive [+] cable first).
6. Start the engine. The initial startup may be slow and there may be smoke and rough operation for a few minutes until the oil in the cylinder burns off. If the engine does not start, clean or replace the spark plugs as they may have been fouled by the oil added to the cylinder when the equipment was stored.

OnaFresh is a trademark of the Onan Corporation.

# Periodic Maintenance

Periodic maintenance is essential for top engine performance. Use Table 2 as a guide for normal periodic maintenance. Under hot or dusty operating conditions some maintenance operations should be performed more frequently, as indicated by the footnotes in the table. Keep a log of maintenance performed and the hours run. Recording maintenance will help you keep it regular and provide a basis for

supporting warranty claims.

Maintenance, replacement or repair of emission control devices and systems may be performed by any engine repair establishment or individual. However, warranty work must be completed by an authorized Onan dealer or distributor.

**TABLE 2. PERIODIC ENGINE MAINTENANCE SCHEDULE**

MAINTENANCE OPERATION	MAINTENANCE FREQUENCY								
	Break-in		Every Day or Every 8 Hours	Every 50 Hours	Every Month	Every 100 Hours	Every 200 Hours	Every 500 Hours	Every 1,000 Hours
	After First 24 Hours	After First 50 Hours							
Inspect Engine			x <sup>1</sup>						
Check Oil Level			x						
Clean Air Cleaner Foam Wrapper				x <sup>2</sup>					
Clean Cylinder Cooling Fins				x <sup>2</sup>					
Check Starting Battery					x <sup>4</sup>				
Change Engine Oil—Standard (Low Profile) Base	x			x <sup>2, 3</sup>					
Change Engine Oil—Medium and High Capacity Bases	x					x <sup>2, 3</sup>			
Change Engine Oil Filter	x					x <sup>2, 3</sup>			
Replace Fuel Filter (if so equipped)							x		
Replace Air Cleaner Element							x <sup>2</sup>		
Replace Spark Plugs								x	
Adjust Engine Valve Clearance (Model P224 only)		x <sup>5</sup>						x <sup>5</sup>	
Adjust Engine Valve Clearance (Models P216, P218 and P220)									x <sup>5</sup>
Clean Cylinder Heads of Deposits									x <sup>5, 6</sup>

1. Check for oil, fuel and exhaust leaks, loose parts and unusual noises and vibrations.
2. Perform more often when operating in dusty conditions.
3. Perform more often when operating in hot conditions.
4. See instructions for battery care provided by the equipment or battery manufacturer.
5. Must be performed by a qualified mechanic according to the engine Service Manual.
6. Clean more often when using leaded fuel or running the engine continuously under light load. Onan 4C carburetor and combustion cleaner is recommended every 200 hours of operation.



## DAILY (8 HOUR) MAINTENANCE

The operator should check the following before the first start of the day and after every eight hours of operation:

1. Inspect fuel lines and fittings for leaks. Repair leaks immediately.
2. Look and listen for exhaust system leaks while the engine is running. Look for cracks and severe rusting in the muffler and tailpipe. Have all leaks repaired before continuing to operate the equipment.

**⚠ WARNING** *Hot exhaust parts can cause severe burns. Allow the engine time to cool before servicing the exhaust system.*

3. Check the engine for dirt and debris and clean the flywheel air inlet screen and cylinder cooling fins as necessary.

**⚠ CAUTION** *A clogged flywheel air inlet screen or dirty cooling fins can cause overheating and engine damage. Keep the cooling fins and air inlet screen clean.*

4. Check the engine oil level. The equipment must be parked on a level surface and the engine stopped. To get an accurate reading, wait a minute or so to allow the oil to settle in the crankcase if the engine has been running.

**⚠ WARNING** *Crankcase pressure can blow hot engine oil out the fill tube causing severe burns. Always stop the engine before removing the oil fill cap.*

Turn the oil fill cap (Figure 3) counterclockwise and then lift it from the fill tube. Wipe the dipstick clean and push it back into the oil fill tube until the cap seats and then withdraw it to check the oil level.

If the oil level is low, add API Class SG or SH oil (also SG/CD, SG/CE, SH/CD or SH/CE) having

an SAE viscosity grade appropriate for the expected temperatures, as indicated by Table 1.

DO NOT FILL TO A LEVEL ABOVE THE FULL MARK ON THE DIPSTICK. Drain the excess oil if too much has been added.

**⚠ CAUTION** *Too much oil can cause high oil consumption, high operating temperatures and oil foaming. Too little oil can cause severe engine damage. Keep the oil level between the Full and Add marks on the dipstick.*

Reinstall the dipstick and cap after checking or adding oil, turning it clockwise until it is secure.

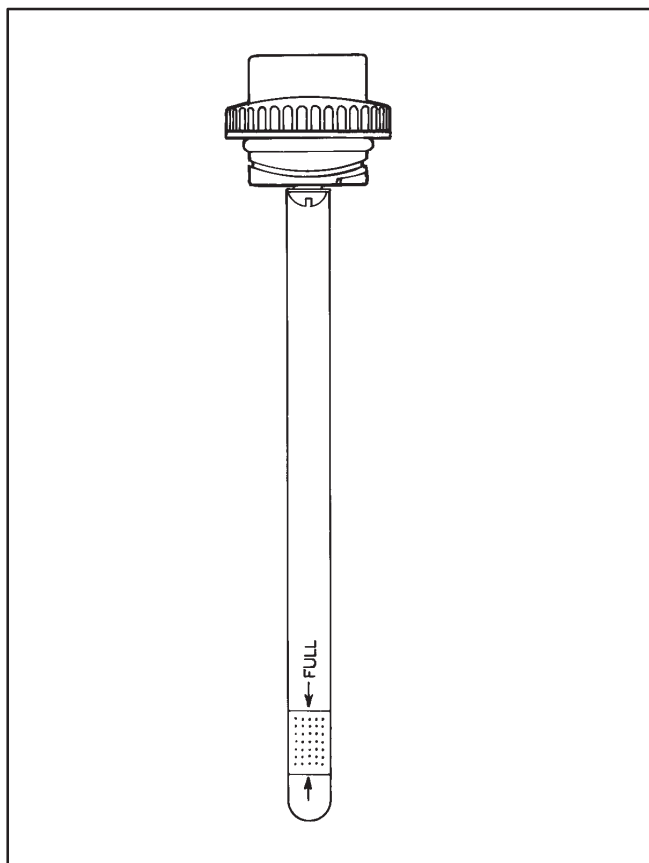

FIGURE 3. OIL FILL CAP AND DIPSTICK

---

## ENGINE OIL AND FILTER CHANGE

**⚠WARNING** *State and federal agencies have determined that contact with used engine oil can cause cancer or reproductive toxicity. Take care to limit skin contact and breathing of vapors as much as possible. Use rubber gloves and wash exposed skin.*

Refer to Table 2 for scheduled oil change and filter replacement. See Figure 2 on Page 3 for oil filter and oil drain locations.

1. Run the engine until it is warm. Stop the engine and disconnect the spark plug and, if so equipped, the battery (negative [-] cable).

**⚠WARNING** *Accidental starting of the engine can result in severe personal injury or death. Always disconnect the spark plug and the battery (negative [-] cable) before changing oil.*

2. Remove the oil fill cap.

**⚠WARNING** *Crankcase pressure can blow hot engine oil out the fill opening causing severe burns. Always stop the engine before removing the oil fill cap.*

3. Place a pan under the oil drain opening and remove the oil drain plug. Reinstall the plug securely after the oil has drained completely.
4. Spin off the oil filter canister, drain the oil and discard the filter according to local regulations.

5. Thoroughly wipe off the filter mounting surface.
6. Make sure the gasket is in place on the filter canister and apply a thin film of oil to the gasket.
7. Spin on the new filter canister by hand until the gasket just touches the mounting pad and then turn it an additional 1/2 to 3/4 turn. Do not over-tighten.
8. Refill with API Class SG or SH oil (also SG/CD, SG/CE, SH/CD or SH/CE) having an SAE viscosity grade appropriate for the expected temperatures, as indicated by Table 1. See *Specifications* for the oil capacity.

DO NOT FILL TO A LEVEL ABOVE THE FULL MARK ON THE DIPSTICK. Drain the excess oil if too much has been added.

**⚠CAUTION** *Too much oil can cause high oil consumption, high operating temperatures and oil foaming. Too little oil can cause severe engine damage. Keep the oil level between the Full and Add marks on the dipstick.*

9. Reconnect the spark plug and battery.
10. Start the engine and run it for a short time while checking for oil leaks around the drain plug and oil filter. Do not over-tighten: tighten only as necessary to eliminate leaks.
11. Used oil is harmful to the environment. Pour the used oil into a sealed container and deliver it to the nearest recycling center.

## AIR CLEANER MAINTENANCE

Refer to Table 2 for scheduled foam wrapper maintenance and air cleaner element replacement.

### Foam Wrapper Maintenance

See Figure 4. When performing maintenance on the foam wrapper only, do not remove the inner air cleaner cover. Remove and wash the foam wrapper in water and detergent. Squeeze the foam wrapper dry like a sponge. Rinse with clean water and allow it to dry. Coat the wrapper evenly with one tablespoon (14 grams) of SAE 30 engine oil. Knead the oil into the wrapper and wring out the excess oil.

Failure to adequately wring out excess oil from the wrapper may cause a drop in engine power due to a restriction of inlet air.

Install the foam wrapper over the paper air cleaner element by stretching it over the inner cover. Completely cover all exposed paper pleats on the air cleaner paper element. Replace the foam wrapper when it becomes torn or stretched.

### Air Cleaner Element Replacement

To keep anything from entering the carburetor and engine while the air cleaner element is off, pull the choke knob to the full-choke position to close the choke plate in the carburetor. Remove the outer cover and wipe away loose dust and debris from the air cleaner assembly. Remove the inner air cleaner mounting nut and cover. Remove the air filter paper element and foam wrapper from the engine. Wipe off dust and debris from the air cleaner base.

Install the new paper element and secure it with the inner cover and mounting nut. Reinstall the foam wrapper and outer cover.

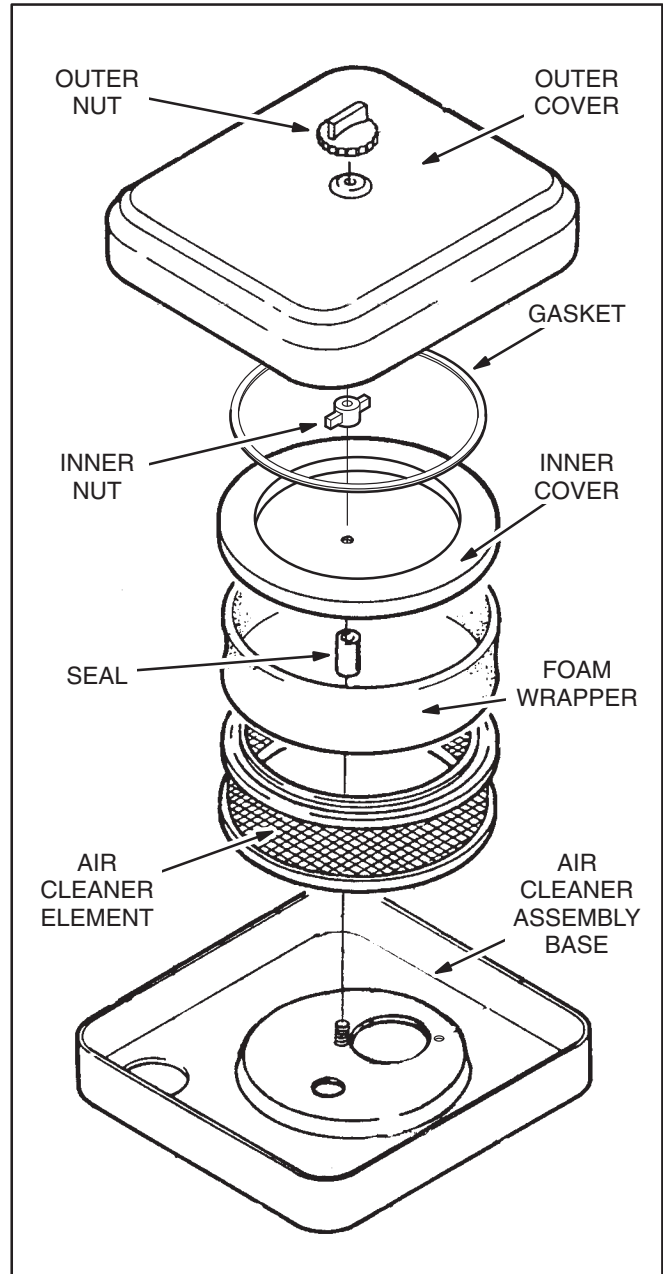

FIGURE 4. AIR CLEANER ASSEMBLY

---

## COOLING SYSTEM MAINTENANCE

Refer to Table 2 for scheduled cleaning of the cylinder cooling fins.

Use compressed air or a pressure washer to clean the cylinder cooling fins. Take the following precautions.

1. Wear safety glasses.

**⚠WARNING** *Always wear safety glasses when using compressed air or a pressure washer to avoid severe eye damage.*

2. Let the engine cool, especially when using a pressure washer. The temperature stresses caused by cleaning a hot engine can crack the cylinder.
3. Observe all of the manufacturer's instructions and precautions when using a pressure washer.

## FUEL FILTER REPLACEMENT

Refer to Table 2 for scheduled gasoline fuel filter replacement and Figure 2 for the location, if so equipped. Also refer to the equipment Operator's Manual regarding any supplemental fuel filters that may have been provided and the recommended frequency for their replacement.

Take care not to spill fuel when disconnecting the fuel line from the filter. Allow the engine to cool before disconnecting the fuel line so as to prevent igniting any fuel that may be spilled. Close any shutoff valve that may be provided in the fuel line. If the filter is of the in-line type, it is usually removable by loosening the inlet and outlet hose clamps.

**⚠WARNING** *Gasoline is highly flammable and can cause severe personal injury or death.*

*Let the engine cool and close any fuel line shutoff valve before disconnecting the fuel line from the filter.*

*Do not smoke if you smell gasoline or are near fuel tanks or gasoline-burning equipment or are in an area sharing ventilation with such equipment. Keep flames, sparks, pilot lights, electrical arcs and arc-producing equipment and all other sources of ignition well away.*

## SPARK PLUG REPLACEMENT

Refer to Table 2 for scheduled spark plug replacement and *Specifications* for gap specifications.

To prevent crossthreading the spark plug always thread it in by hand until it seats. Then turn it with a wrench an additional 1/16 turn (22-1/2°). If you have a torque wrench, tighten the spark plugs to 11 lbs-ft (14 N-m).

# Adjustments

## CARBURETOR ADJUSTMENTS

These engines have precision-manufactured carburetors which are not adjustable.

### RECONNECTING THE CHOKE CABLE

If necessary, and if this is a gasoline engine with a manual choke, refer to Figure 5 or 6, as appropriate, and reconnect and reclamp the choke cable as follows:

1. Stop the engine and disconnect the spark plugs and, if so equipped, the battery (negative [-] cable).

**⚠WARNING** *Accidental starting of the engine can result in severe personal injury or death. Always disconnect the spark plug and battery (negative [-] cable) before re-setting the engine control cables.*

2. Push the equipment choke knob to the full-open choke position.
3. Connect the choke cable to the choke lever. (The cable will either hook into the choke lever or be clamped by a screw in a swivel on the choke lever. See Figure 6.) Pull the slack out of the cable and clamp it.
4. Check for smooth movement and full travel of the equipment choke knob. Remove the air cleaner element as explained under *Periodic Maintenance* to see that the choke plate opens and closes fully.
5. Reassemble the air cleaner and reconnect the spark plug and battery.

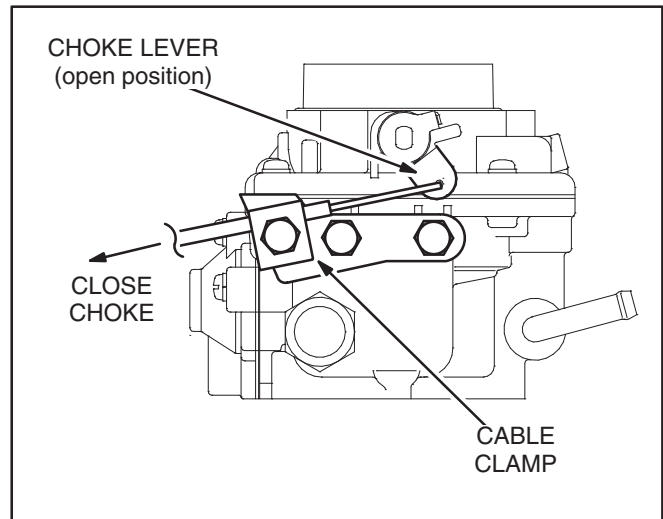

FIGURE 5. REAR-PULL CHOKE CABLE

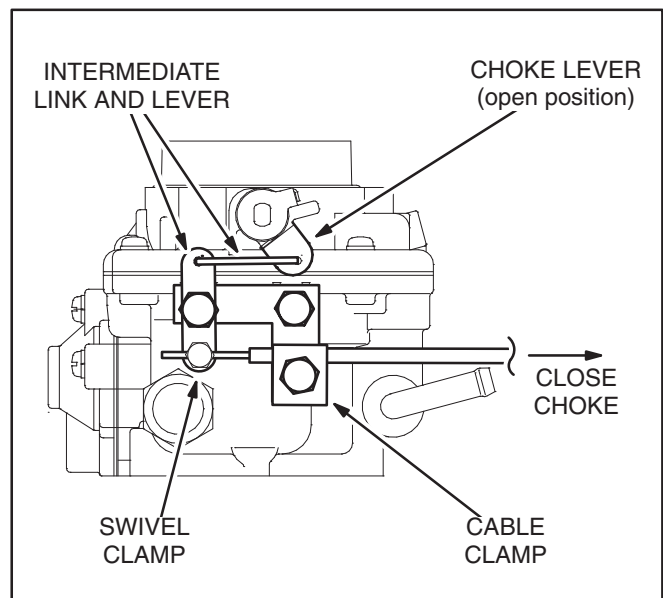

FIGURE 6. FRONT-PULL CHOKE CABLE

## ENGINE SPEED ADJUSTMENTS

Normally there is no need to adjust engine speed. These instructions are for the equipment manufacturer in setting up and adjusting the equipment.

Engine speed adjustment must be attempted only by a qualified mechanic and the adjustments must be made using an accurate tachometer. Set the low-idle and high-idle speeds to the values specified in the equipment Operator's Manual. In the absence of such specifications it is recommended that low-idle speed be adjusted to 1100 RPM and high-idle speed to 3400 RPM.

**⚠WARNING** *Adjusting the engine speed to a value above that specified by the equipment manufacture could cause the equipment to operate at speeds in violation of Federal and State Standards for Safety for the equipment.*

**⚠WARNING** *Moving parts can cause severe personal injury or death. Take care when measuring engine speed with a tachometer and follow the meter instructions. You must be a qualified mechanic.*

Referring to Figure 7, adjust the low-idle and high-idle engine speeds as follows:

1. Start the engine, observing all of the equipment manufacturer's instructions and precautions.
2. If the throttle cable has already been connected, loosen the clamp at the engine and back out the low-idle speed stop screw so that the speed stop screw on the carburetor touches its stop. Adjust engine speed to 1000 RPM with the carburetor speed stop screw.
3. Turn the low-idle speed stop screw to obtain the specified low-idle speed.
4. Move the engine throttle link up against its stop tang and hold it there while bending the tang as necessary to obtain the specified high-idle speed.
5. Hook the engine throttle link with the throttle cable, pull the slack out of the throttle cable and tighten the clamp. Check for full, smooth move-

ment of the engine throttle link between its two stop positions when the equipment throttle lever is moved through its full range.

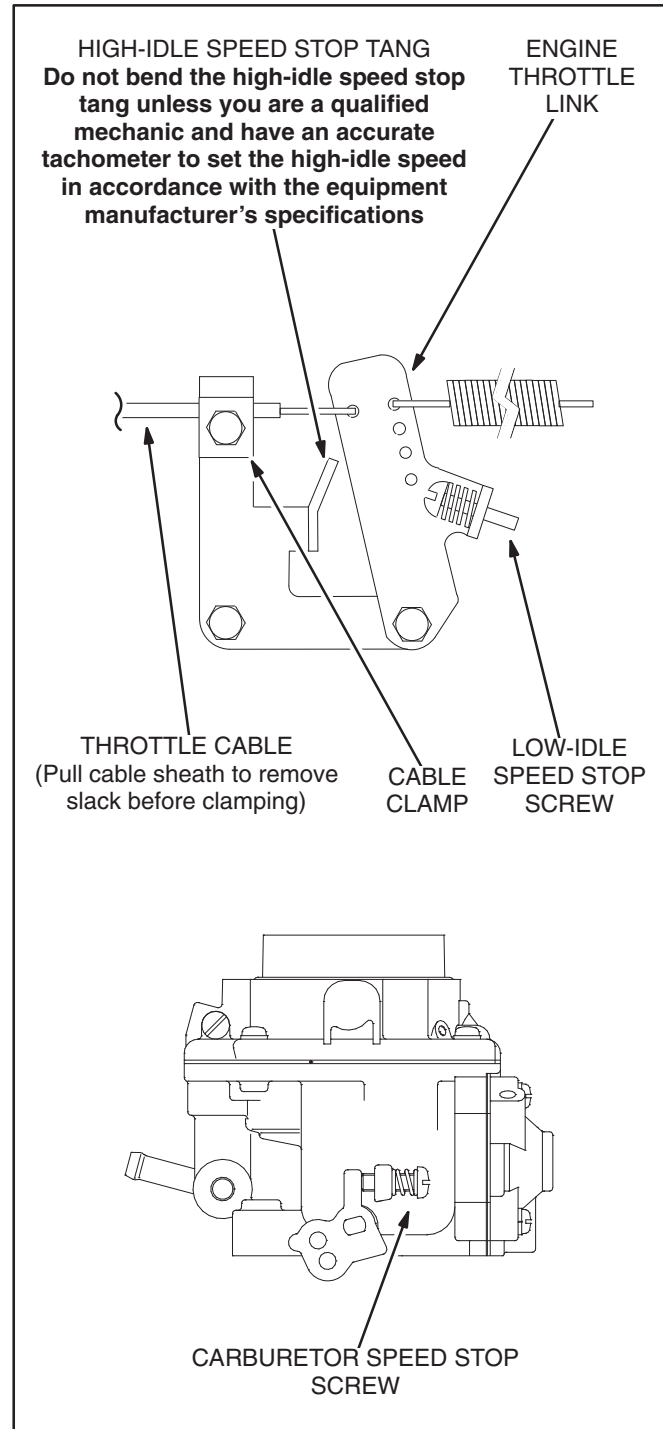

**FIGURE 7. TYPICAL ARRANGEMENT OF PARTS FOR SPEED ADJUSTMENTS**

# Troubleshooting

Table 3 provides basic troubleshooting guidance. If you fail to resolve the problem after taking the corrective actions suggested, contact the equipment or Onan dealer.

**sonnel with knowledge of fuels, electricity, and machinery hazards should perform service procedures. Review the safety precautions inside the cover page.**

**⚠WARNING** Many troubleshooting procedures present hazards that can result in severe personal injury or death. Only qualified service per-

**⚠WARNING** Hot engine parts can cause severe burns. Always allow the engine time to cool before performing any maintenance or service.

TABLE 3. TROUBLESHOOTING

Problem	Corrective Action
1. The engine fails to crank.	<ul style="list-style-type: none"> <li>a. Release the clutch (if so equipped).</li> <li>b. Clean and tighten the positive (+) and negative (-) battery cable connections at the battery and the engine.</li> <li>c. Recharge the battery. Refer to the equipment or battery manufacturer's recommendations.</li> </ul>
2. The engine cranks slowly.	<ul style="list-style-type: none"> <li>a. Release the clutch (if so equipped).</li> <li>b. Clean and tighten the positive (+) and negative (-) battery cable connections at the battery and the engine.</li> <li>c. Recharge the battery. Refer to the equipment or battery manufacturer's recommendations.</li> <li>d. Change engine oil to oil having the proper viscosity for the ambient temperature. See Table 1.</li> </ul>
3. The engine cranks but fails to start.	<ul style="list-style-type: none"> <li>a. Check the fuel tank and fill if necessary.</li> <li>b. Open any closed fuel shut off valve.</li> <li>c. Check engine oil level and add oil as necessary.</li> <li>d. Reconnect and reclamp the choke cable (manual-choke gasoline engines only). See <i>Adjustments</i>.</li> <li>e. Service the air cleaner.</li> <li>f. Replace the fuel filter(if provided on gasoline engine).</li> <li>g. Replace the spark plugs.</li> </ul>
4. The engine runs and then stops.	<ul style="list-style-type: none"> <li>a. Check the fuel tank and fill if necessary.</li> <li>b. Check the engine oil level and add oil as necessary. Drain excess oil if the level is above the dipstick Full mark.</li> <li>c. Reconnect and reclamp the choke cable (manual-choke gasoline engines only). See <i>Adjustments</i>.</li> </ul>
5. The engine exhausts black (dark) smoke.	<ul style="list-style-type: none"> <li>a. Service the air cleaner.</li> <li>b. Reconnect and reclamp the choke cable (manual-choke gasoline engines only). See <i>Adjustments</i>.</li> </ul>
6. The engine misfires.	<ul style="list-style-type: none"> <li>a. Replace the spark plugs.</li> </ul>

# Specifications

Model	P216	P218	P220	P224
Power at Rated Speed (3600 RPM)	16 HP (11.9 kW)	18 HP (13.4 kW)	20 HP (14.9 kW)	24 HP (17.9 kW)
Bore	3.250 inch (83 mm)	3.250 inch (83 mm)	3.250 inch (83 mm)	3.563 inch (90 mm)
Stroke	2.625 inch (67 mm)	2.875 inch (73 mm)	2.875 inch (73 mm)	3.000 inch (76 mm)
Displacement	44 inch <sup>3</sup> (714 cc)	48 inch <sup>3</sup> (782 cc)	48 inch <sup>3</sup> (782 cc)	60 inch <sup>3</sup> (980 cc)
Compression Ratio	6.5 : 1	7.0 : 1	7.0 : 1	7.0 : 1
Engine Type	Horizontally Opposed 2-Cylinder, 4-Stroke Cycle, Spark-Ignited, Side-Valve, Air-Cooled, Horizontal-Shaft			
Oil Capacity—Low Profile Base*	1.8 quart (1.7 l)			
Oil Capacity—Medium Capacity Base*	2.5 quart (2.4 l)			
Oil Capacity—High Capacity Base*	3.0 quart (2.8 l)			
Intake Valve Clearance (Cold)	0.005 inch (0.13 mm)			
Exhaust Valve Clearance (Cold)	0.013 inch (0.33 mm)			
Spark Plug Gap	0.025 inch (0.64 mm)			
Spark Plug Tightening Torque	11 lbs-ft (14 N-m)			
Ignition Timing	20° BTDC (Non-adjustable electronic ignition)			
* – With filter. See <i>Periodic Maintenance</i> for oil filling instructions.				



# Information for California Engine Users

This engine meets the requirements of California's Exhaust Emissions Standards as stated on the nameplate. Figure 1 (Page 2) illustrates where this information appears on the nameplate.

As a California user of this engine, please be aware that unauthorized modifications or replacement of fuel, exhaust, air intake, or speed control system components that affect engine emissions are prohibited. Unauthorized modification, removal or replacement of the engine label is prohibited.

You should carefully review Operator (Owner), Installation and other manuals and information you receive with your engine or equipment. If you are unsure that the installation, use, maintenance or service of your engine or equipment is authorized, you should seek assistance from an approved Onan engine dealer or an approved dealer for your equipment.

California engine users may use Table 4 as an aid in locating information related to the California Air Resources Board requirements for emissions control.

**TABLE 4. EMISSIONS CONTROL INFORMATION**

Engine Warranty Information	The California emissions control warranty statement is located in the same packet of information as this manual when the engine is shipped from the factory.
Engine Valve Lash	See <i>Specifications</i> .
Engine Ignition Timing	See <i>Specifications</i> .
Engine Fuel Requirements	<p><b>Gasoline Models:</b> The engine is certified to operate on unleaded gasoline. See Fuel Recommendations in <i>Introduction</i>.</p> <p><b>LPG Models:</b> The engine is certified to operate on LPG. See Fuel Recommendations in <i>Introduction</i>.</p> <p><b>Natural Gas Models:</b> The engine is certified to operate on commercial natural gas.</p>
Engine Fuel Mixture Settings	<p><b>Gasoline Models:</b> The engine has a precision-manufactured carburetor which is not adjustable.</p> <p><b>LPG Models:</b> The engine has a precision-manufactured carburetor and converter/regulator which are not adjustable.</p> <p><b>Natural Gas Models:</b> The engine has a precision-manufactured carburetor and regulator which are not adjustable.</p>
Engine Lubricating Oil Requirements	See Engine Oil Recommendations in <i>Introduction</i> .
Engine Adjustments	See <i>Adjustments</i> .
Engine Emission Control System	The engine emission control system consists of internal engine modifications ( <b>EM</b> ).



Cummins Power Generation  
1400 73rd Avenue N.E.  
Minneapolis, MN 55432  
763-574-5000  
Fax: 763-528-7229

Cummins and Onan are registered trademarks of Cummins Inc.