

Installation Manual

GenSet Model GNAA, GNAB, GNAC

with PowerCommand[®] Control
PCC1301

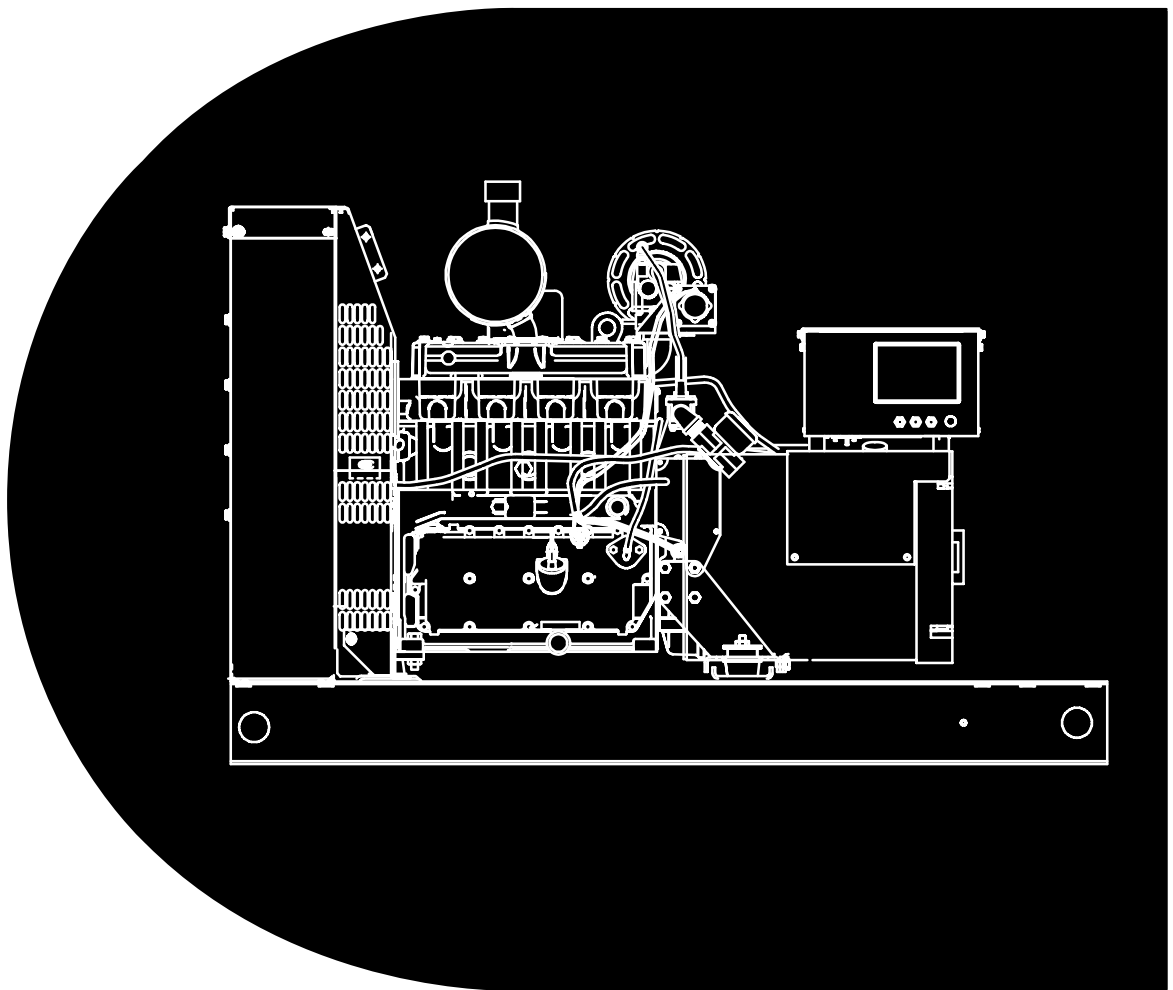
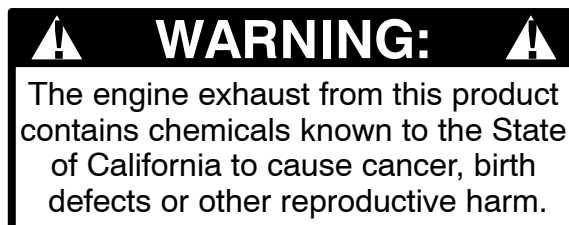

Table of Contents

SECTION	TITLE	PAGE
	IMPORTANT SAFETY INSTRUCTIONS	iii
1	INTRODUCTION	
	About this Manual	1-1
	Installation Overview	1-1
2	SPECIFICATIONS	2-1
3	MOUNTING THE GENERATOR SET	
	General	3-1
	Location	3-1
	Mounting	3-3
	Access to Set	3-3
4	MECHANICAL CONNECTIONS	
	General	4-1
	Fuel System	4-1
	Exhaust System	4-3
	Ventilation and Cooling	4-5
5	DC CONTROL WIRING	
	Control Wiring	5-1
	TB1 Remote Monitor/Control Connections	5-2
	Switched B+	5-2
	Universal Annunciator	5-2
	I/O Module	5-3
	Run Relays (K10, K11)	5-3
	Batteries	5-4



SECTION	TITLE	PAGE
6	AC ELECTRICAL CONNECTIONS	
	General	6-1
	Transfer Switch	6-2
	AC Wiring	6-3
	Control Heater (Optional)	6-6
	Coolant Heater (Optional)	6-6
	Generator Heater (Optional)	6-6
7	PRESTART PREPARATION	
	General	7-1
	InPower Service Tool General Information	7-1
	Electrical System	7-1
	PCC Options Prestart Checks	7-2
	Screen Adjust Menu	7-2
	Starting	7-4
8	INSTALLATION CHECKLIST	
	General	8-1
	Generator Set Support	8-1
	Cooling Air Flow	8-1
	Fuel System	8-1
	Exhaust System	8-2
	AC and DC Wiring	8-2
	Generator Set Prestart	8-2
9	WIRING DIAGRAMS	
	Customer Connection Diagram	9-1

IMPORTANT SAFETY INSTRUCTIONS

SAVE THESE INSTRUCTIONS – This manual contains important instructions that should be followed during installation and maintenance of the generator and batteries.

Before operating the generator set (genset), read the Operator's Manual and become familiar with it and the equipment. **Safe and efficient operation can be achieved only if the equipment is properly operated and maintained.** Many accidents are caused by failure to follow fundamental rules and precautions.

The following symbols, found throughout this manual, alert you to potentially dangerous conditions to the operator, service personnel, or the equipment.

⚠ DANGER *This symbol warns of immediate hazards which will result in severe personal injury or death.*

⚠ WARNING *This symbol refers to a hazard or unsafe practice which can result in severe personal injury or death.*

⚠ CAUTION *This symbol refers to a hazard or unsafe practice which can result in personal injury or product or property damage.*

FUEL AND FUMES ARE FLAMMABLE

Fire, explosion, and personal injury or death can result from improper practices.

- DO NOT fill fuel tanks while engine is running, unless tanks are outside the engine compartment. Fuel contact with hot engine or exhaust is a potential fire hazard.
- DO NOT permit any flame, cigarette, pilot light, spark, arcing equipment, or other ignition source near the generator set or fuel tank.
- Fuel lines must be adequately secured and free of leaks. Fuel connection at the engine should be made with an approved flexible line. Do not use copper piping on flexible lines as copper will become brittle if continuously vibrated or repeatedly bent.
- Natural gas is lighter than air, and will tend to gather under hoods. Propane is heavier than air, and will

tend to gather in sumps or low areas. NFPA code requires all persons handling propane to be trained and qualified.

- Be sure all fuel supplies have a positive shutoff valve.
- Be sure battery area has been well-ventilated prior to servicing near it. Lead-acid batteries emit a highly explosive hydrogen gas that can be ignited by arcing, sparking, smoking, etc.

EXHAUST GASES ARE DEADLY

- Provide an adequate exhaust system to properly expel discharged gases away from enclosed or sheltered areas and areas where individuals are likely to congregate. Visually and audibly inspect the exhaust daily for leaks per the maintenance schedule. Make sure that exhaust manifolds are secured and not warped. Do not use exhaust gases to heat a compartment.
- Be sure the unit is well ventilated.
- Engine exhaust and some of its constituents are known to the state of California to cause cancer, birth defects, and other reproductive harm.

MOVING PARTS CAN CAUSE SEVERE PERSONAL INJURY OR DEATH

- Keep your hands, clothing, and jewelry away from moving parts.
- Before starting work on the generator set, disconnect battery charger from its AC source, then disconnect starting batteries, negative (-) cable first. This will prevent accidental starting.
- Make sure that fasteners on the generator set are secure. Tighten supports and clamps, keep guards in position over fans, drive belts, etc.
- Do not wear loose clothing or jewelry in the vicinity of moving parts, or while working on electrical equipment. Loose clothing and jewelry can become caught in moving parts. Jewelry can short out electrical contacts and cause shock or burning.
- If adjustment must be made while the unit is running, use extreme caution around hot manifolds, moving parts, etc.

ELECTRICAL SHOCK CAN CAUSE SEVERE PERSONAL INJURY OR DEATH

- Remove electric power before removing protective shields or touching electrical equipment. Use rubber insulative mats placed on dry wood platforms over floors that are metal or concrete when around electrical equipment. Do not wear damp clothing (particularly wet shoes) or allow skin surface to be damp when handling electrical equipment.
- Use extreme caution when working on electrical components. High voltages can cause injury or death. **DO NOT** tamper with interlocks.
- Follow all applicable state and local electrical codes. Have all electrical installations performed by a qualified licensed electrician. Tag and lock open switches to avoid accidental closure.
- **DO NOT CONNECT GENERATOR SET DIRECTLY TO ANY BUILDING ELECTRICAL SYSTEM.** Hazardous voltages can flow from the generator set into the utility line. This creates a potential for electrocution or property damage. Connect only through an approved isolation switch or an approved paralleling device.

GENERAL SAFETY PRECAUTIONS

- Coolants under pressure have a higher boiling point than water. **DO NOT** open a radiator or heat exchanger pressure cap while the engine is running. Allow the generator set to cool and bleed the system pressure first.
- Benzene and lead, found in some gasoline, have been identified by some state and federal agencies as causing cancer or reproductive toxicity. When checking, draining or adding gasoline, take care not to ingest, breathe the fumes, or contact gasoline.
- Used engine oils have been identified by some state or federal agencies as causing cancer or reproductive toxicity. When checking or changing engine oil, take care not to ingest, breathe the fumes, or contact used oil.
- Keep multi-class ABC fire extinguishers handy. Class A fires involve ordinary combustible materials such as wood and cloth; Class B fires, combustible and flammable liquid fuels and gaseous fuels; Class C fires, live electrical equipment. (ref. NFPA No. 10).
- Make sure that rags are not left on or near the engine.
- Make sure generator set is mounted in a manner to prevent combustible materials from accumulating under the unit.
- Remove all unnecessary grease and oil from the unit. Accumulated grease and oil can cause overheating and engine damage which present a potential fire hazard.
- Keep the generator set and the surrounding area clean and free from obstructions. Remove any debris from the set and keep the floor clean and dry.
- Do not work on this equipment when mentally or physically fatigued, or after consuming any alcohol or drug that makes the operation of equipment unsafe.
- Substances in exhaust gases have been identified by some state or federal agencies as causing cancer or reproductive toxicity. Take care not to breathe or ingest or come into contact with exhaust gases.
- Do not store any flammable liquids, such as fuel, cleaners, oil, etc., near the generator set. A fire or explosion could result.
- Wear hearing protection when going near an operating generator set.
- To prevent serious burns, avoid contact with hot metal parts such as radiator, turbo charger and exhaust system.

KEEP THIS MANUAL NEAR THE GENSET FOR EASY REFERENCE

1. Introduction

ABOUT THIS MANUAL

This manual provides installation instructions for the generator set models listed on the front cover. This includes the following information:

Mounting Recommendations - for fastening generator set to base and space requirements for normal operation and service.

Mechanical and Electrical Connections - covers most aspects of the generator set installation.

Prestart – checklist of items or procedures needed to prepare generator set for operation.

Initial Startup – test complete system to ensure proper installation, satisfactory performance, and safe operation. Refer to Operators Manual for troubleshooting information.

Installation Checklist – reference checks upon completion of installation.

This manual DOES NOT provide application information for selecting a generator set or designing the complete installation. If it is necessary to design the various integrated systems (fuel, exhaust, cooling, etc.), additional information is required. Review standard installation practices. For engineering data specific to the generator set, refer to the *Specification and Data Sheets*. For application information, refer to Application Manual T-030, "Liquid Cooled Generator Sets".

INSTALLATION OVERVIEW

These installation recommendations apply to typical installations with standard model generator sets. Whenever possible, these recommendations also cover factory designed options or modifica-

tions. However, because of the many variables in any installation, it is not possible to provide specific recommendations for every situation. If there are any questions not answered by this manual, contact your nearest Cummins Power Generation distributor for assistance.

Application and Installation

A power system must be carefully planned and correctly installed for proper operation. This involves two essential elements: application and installation.

Application (as it applies to generator set installations) refers to the design of the complete power system that usually includes power distribution equipment, transfer switches, ventilation equipment, mounting pads, and cooling, exhaust, and fuel systems. Each component must be correctly designed so the complete system will function as intended. Application and design is an engineering function generally done by specifying engineers or other trained specialists. Specifying engineers or other trained specialists are responsible for the design of the complete power system and for selecting the materials and products required.

Installation refers to the actual set-up and assembly of the power system. The installers set up and connect the various components of the system as specified in the system design plan. The complexity of the system normally requires the special skills of qualified electricians, plumbers, sheetmetal workers, etc. to complete the various segments of the installation. This is necessary so all components are assembled using standard methods and practices.

Safety Considerations

The generator set has been carefully designed to provide safe and efficient service when properly installed, maintained, and operated. However, the overall safety and reliability of the complete system is dependent on many factors outside the control of the generator set manufacturer. To avoid possible safety hazards, make all mechanical and electrical connections to the generator set exactly as specified in this manual. All systems external to the generator (fuel, exhaust, electrical, etc.) must comply with all applicable codes. Make certain all required inspections and tests have been completed and all code requirements have been satisfied before certifying the installation is complete and ready for service.

Standby Heating Devices

In accordance with NFPA 110, Cummins Power Generation recommends installing standby generator sets (life safety systems) equipped with engine jacket water coolant heaters in locations where the minimum ambient temperature is above 40°F (4°C). NFPA also requires that the engine be heated as necessary to maintain the water jacket temperature determined by the manufacturer for cold start and load acceptance for the type of system. Although most Cummins Power Generation generator sets will start in temperatures down to -25°F (-32°C) when equipped with engine jacket

water coolant heaters, it might take more than 10 seconds to warm the engine before a load can be applied when ambient temperatures are below 40°F (4°C).

On generator sets equipped with a graphic display, the **Low Coolant Temperature (Code 203)** message, in conjunction with illumination of the Warning LED, is provided to meet the requirements of NFPA 110. The engine cold sensing logic initiates a warning when the engine jacket water coolant temperature falls below 70°F (21°C). In applications where the ambient temperature falls below 40°F (4°C), a cold engine may be indicated even though the coolant heaters are connected and operating correctly. Under these conditions, although the generator set may start, it may not be able to accept load within 10 seconds. When this condition occurs, check the coolant heaters for proper operation. If the coolant heaters are operating properly, other precautions may be necessary to warm the engine before applying a load.

Product Modifications

Agency certified products purchased from Cummins Power Generation comply only with those specific requirements and as noted on company product specification sheets. Subsequent modifications must meet commonly accepted engineering practices and/or local and national codes and standards. Product modifications must be submitted to the local authority having jurisdiction for approval.

2. Specifications

	MODEL		
	GNAA	GNAB	GNAC
GENERATOR: Single-Bearing, 4-Pole Rotating Field, Brushless, Electronically Regulated			
60 Hz LPG* Power Output Rating	7.0 kW	11.5 kW	16.0 kW
60 Hz NG* Power Output Rating	6.0 kW	10.0 kW	14.0 kW
50 Hz LPG* Power Output Rating	6.5 kW	9.0 kW	12.5 kW
50 Hz NG* Power Output Rating	4.7 kW	7.8 kW	10.9 kW
FULL LOAD FUEL CONSUMPTION:			
60 Hz LPG*	45 cfh	70 cfh	87 cfh
60 Hz NG*	95 cfh	144 cfh	206 cfh
50 Hz LPG*	33 cfh	50 cfh	67 cfh
50 Hz NG*	75 cfh	111 cfh	157 cfh
ENGINE: Electronically Governed, 4-Stroke Cycle Spark-Ignited, Water Cooled			
Number of Cylinders	2	3	4
Bore	86 mm (3.38 inch)	86 mm (3.38 inch)	86 mm (3.38 inch)
Stroke	80 mm (3.15 inch)	80 mm (3.15 inch)	80 mm (3.15 inch)
Displacement	0.93 liter (56.75 in ³)	1.40 liter (85.13 in ³)	1.86 liter (113.50 in ³)
Compression Ratio	9.5:1	9.5:1	9.5:1
Firing Order	1-2	1-2-3	1-3-4-2
Coolant Capacity	6.4 liter (6.8 quart)	7.1 liter (7.5 quart)	7.6 liter (8.0 quart)
Engine Oil Capacity**	3.4 liter (3.6 quart)	4.5 liter (4.7 quart)	5.6 liter (5.9 quart)
Ignition Timing—LPG*	10° BTDC		
Ignition Timing—NG*	20° BTDC		
Rotation	Clockwise (looking at radiator end)		
Valve Lash	Hydraulic tappets		
Spark Gap	0.021 inch (0.53 mm)		
Spark Plug Torque	28 lb-ft (40 N-m)		
Gas Supply Pressure—LPG* and NG*	5.5-13.6 Inches Water Column (1.4-3.4 kPa)		
Fuel Supply Connection	3/4 inch NPT female		
Maximum Exhaust Back Pressure	15 inch (381 mm) WC (Water Column)		
BATTERIES:***			
Nominal Battery Voltage	12 volts		
Minimum CCA (Cold Cranking Amps)	525 amps		
Charging Alternator Output	45 amps		
INSTALLATION SPECIFICATIONS:			
See the appropriate Specification Bulletin and Outline Drawing for minimum cooling air flow; fuel, exhaust and electrical connection points; overall dimensions; weight; etc.			
* LPG (liquefied petroleum gas), NG (natural gas)			
** Includes Oil Filter			
*** A battery mounted in the built-in battery rack in the skid base must be of a type with barbed vent hose fittings for its cells. The vent lines must be routed away from the generator end bell (air inlet) to prevent battery gasses from entering the generator and causing corrosion.			

THIS PAGE LEFT INTENTIONALLY BLANK

3. Mounting the Generator Set

GENERAL

Generator set installations must be engineered so the generator set will function properly under the expected load conditions. Use these instructions as a general guide only. Follow the instructions of the consulting engineer when locating or installing any components. The complete installation must comply with all local and state building codes, fire ordinances, and other applicable regulations. A typical generator set installation is shown in Figure 3-1.

Requirements to be considered prior to installation:

- Level mounting surface
- Adequate cooling air
- Adequate fresh induction air
- Discharge of generator set air
- Non-combustible mounting surface

- Discharge of exhaust gases
- Electrical connections
- Accessibility for operation and servicing
- Noise levels
- Vibration isolation

LOCATION

Generator set location is decided mainly by related systems such as ventilation, wiring, fuel, and exhaust. The set should be located as near as possible to the main power service entrance. Exhaust must not be able to enter or accumulate around inhabited areas.

Provide a location away from extreme ambient temperatures and protect the generator set from adverse weather conditions. An optional housing is available for outdoor operation.

⚠ WARNING

INCORRECT INSTALLATION, SERVICE OR PARTS REPLACEMENT CAN RESULT IN SEVERE PERSONAL INJURY, DEATH, AND/OR EQUIPMENT DAMAGE. SERVICE PERSONNEL MUST BE TRAINED AND EXPERIENCED TO PERFORM ELECTRICAL AND MECHANICAL COMPONENT INSTALLATION.

IMPORTANT

DEPENDING ON YOUR LOCATION AND INTENDED USE, FEDERAL, STATE OR LOCAL LAWS AND REGULATIONS MAY REQUIRE YOU TO OBTAIN AN AIR QUALITY EMISSIONS PERMIT BEFORE BEGINNING INSTALLATION OF YOUR GENSET. BE SURE TO CONSULT LOCAL POLLUTION CONTROL OR AIR QUALITY AUTHORITIES BEFORE COMPLETING YOUR CONSTRUCTION PLANS.

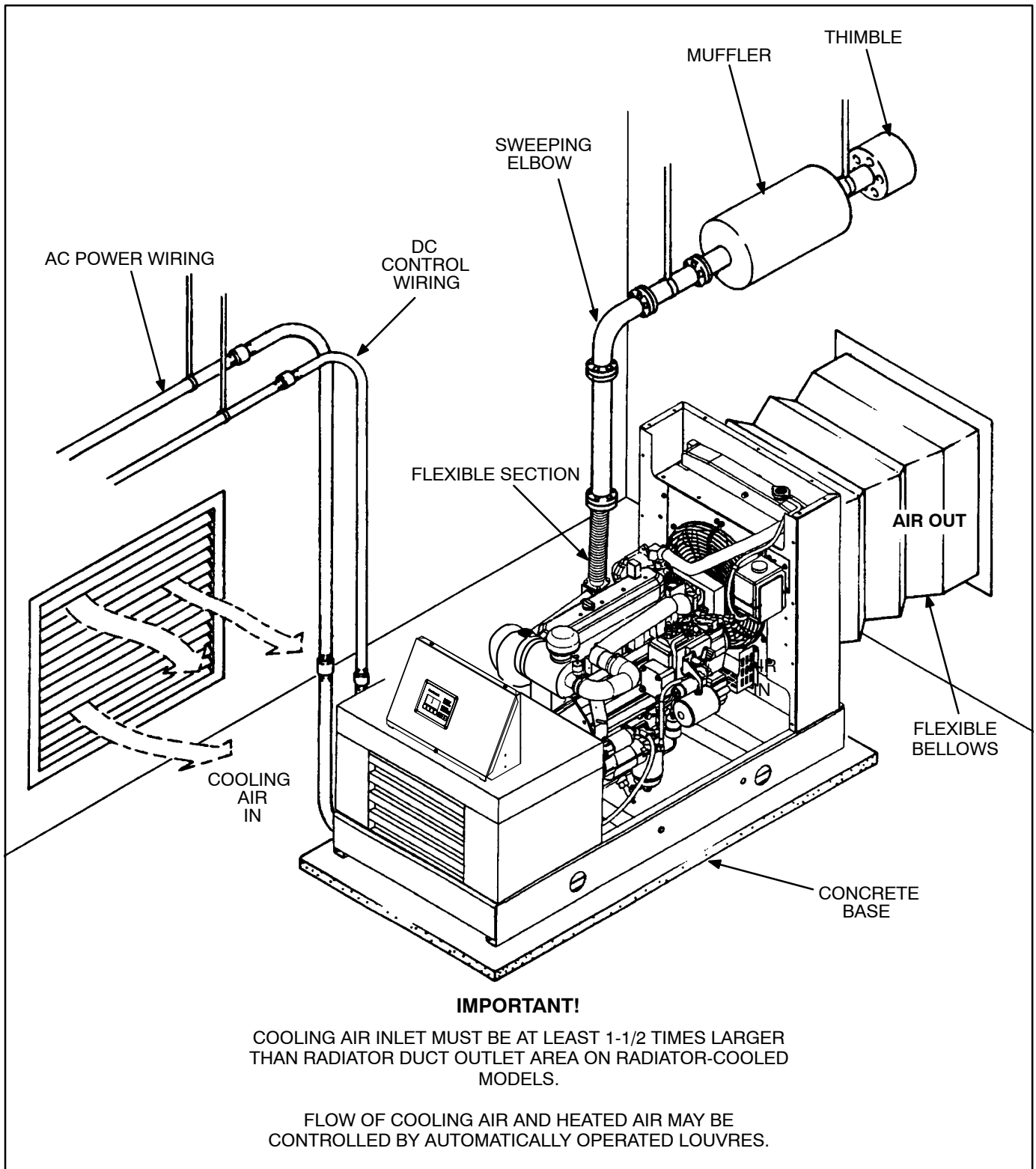

FIGURE 3-1. TYPICAL GENERATOR SET INSTALLATION

MOUNTING

Generator sets are mounted on a steel skid that provides proper support. The engine-generator assembly is isolated from the skid frame by rubber mounts that provide adequate vibration isolation for normal installations. Where required by building codes or special isolation needs, generator sets may be mounted on rubber pads or mechanical spring isolators. The use of unapproved isolators may result in harmful resonances and may void the genset warranty.

Mount the generator set on a substantial and level base such as a concrete pad. A non-combustible material must be used for the pad.

Use 5/8 inch or 16 mm anchored mounting bolts to secure the skid or vibration isolators to the base (Figure 3-2). The 1-1/2 x 6 inch pipe inserted over the mounting bolts allows minor adjustment of the bolts to align them to the holes in the subbase or vibration isolator.

The skid mounting bolt hole locations are shown on the generator set *Outline Drawing* referenced in the *Data Sheet*.

ACCESS TO SET

Generally, at least 1 meter (3 feet) of clearance should be provided on all sides of the generator set for maintenance and service access. (Increase clearance by width of door if optional housing is used.) A raised foundation or slab of 150 mm (6 inches) or more above floor level will make servicing easier.

Lighting should be adequate for operation, maintenance and service operations and should be connected on the load side of the transfer switch so that it is available at all times.

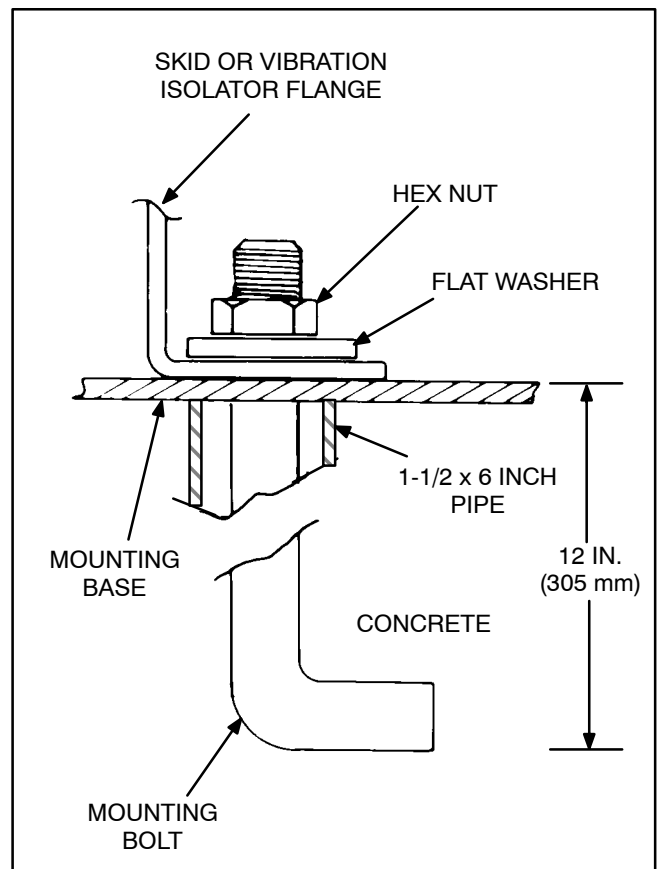

FIGURE 3-2. BOLT DIAGRAM

THIS PAGE LEFT INTENTIONALLY BLANK

4. Mechanical Connections

GENERAL

The generator set mechanical system installation includes connecting the fuel, exhaust, ventilation and cooling systems. Before starting any type of fuel installation, all pertinent state and local codes must be complied with and the installation must be inspected before the unit is put in service.

All pipe threaded fuel system fittings, including container fittings, must be assembled using a pipe joint sealing compound designed for use with LPG/NG.

FUEL SYSTEM

Gensets can be equipped to operate on:

- LPG (vapor or liquid withdrawal)
- NG (natural gas) or
- Combination (NG/LPG)

In all fuel system installations, cleanliness is of the upmost importance. Make every effort to prevent entrance of moisture, dirt or contaminants of any kind. Clean all fuel system components before installing.

Fuel Lines – Routing

A flexible fuel hose(s) or section of flexible fuel hose(s) must be used between the engine's fuel system and fuel supply line to protect the fuel system from damage caused by vibration, expansion and contraction.

⚠WARNING Fuel leaks create fire and explosion hazards which can result in severe personal injury or death. Always use flexible tubing between engine and fuel supply to avoid line failure and leaks due to vibration. The fuel system must meet applicable codes.

Installation of the fuel hose must be done according to all applicable codes and standards, and installa-

tion recommendations provided by the manufacturer. The flexible hose used must be approved by the hose manufacture for use with the genset fuel type and product application.

Support fuel lines to restrain movement and prevent chaffing or contact with sharp edges, electrical wiring and hot exhaust parts.

⚠WARNING Sparks and hot surfaces can ignite fuel, leading to severe personal injury or death. Do not route fuel lines near electrical wiring or hot exhaust parts.

Fuel lines must be routed and secured to maintain a 2 inch (51 mm) minimum clearance from electrical wiring and hot exhaust parts.

Natural Gas/LPG Vapor/LPG Liquid Fuel System

⚠WARNING Gaseous fuels are flammable and explosive and can cause severe personal injury or death. Do not smoke if you smell gas or are near fuel tanks or fuel-burning equipment or are in an area sharing ventilation with such equipment. Keep flames, sparks, pilot lights, electrical arcs and arc-producing equipment and all other sources of ignition well away from genset and areas sharing ventilation. Keep a type ABC fire extinguisher handy.

NFPA Standard No. 58 requires all persons handling and operating LPG to be trained in proper handling and operating procedures.

Gaseous-fuel supply system design, materials, components, fabrication, assembly, installation, testing, inspection, operation and maintenance must comply with the applicable codes. See NFPA Standards No. 37, No. 54 and No. 58.

Most codes require both manual and electric (battery-powered) shutoff valves ahead of the flexible fuel hose(s). The manual valve should be of the indicating type. The electric valve should be wired so that the valve is closed when the genset is off.

Install a dry-type fuel filter ahead of the service pressure regulator to protect the sensitive pressure regulating components and orifices downstream from rust, scale and other solid substances carried along in the gas stream.

See *Specifications* section for natural gas/LPG fuel inlet size. The recommendations in *Application Manual T-030*, should be followed in regard to fuel supply system pipe sizes, manual shutoff valves, fuel filters and gas pressure regulators.

Fuel Pressure

⚠WARNING *High gas supply pressure can cause gas leaks which can lead to fire and severe personal injury or death. Gas supply pressure must be adjusted to Specifications by qualified personnel.*

The gas pressure regulators in each line provide constant gas pressure at the gas mixer under varying load conditions. A pressure test port is provided on the regulator for measuring supply fuel pressures (NG or LPG systems). When measuring supply pressure, the most accurate reading would be on the input side of the solenoid valve.

Fuel supply pressure: The minimum pressure refers to supply pressure under rated load (maximum gas flow).

For LPG (vapor withdrawal) and NG, the maximum permissible fuel supply pressure is 13.6 inches WC (3.4 kPa) and the minimum permissible is 5.5 inches WC (1.4 kPa).

For LPG (liquid withdrawal), the maximum permissible fuel supply pressure is 312 psi (2,153 kPa) under any operating condition.

⚠WARNING *Gaseous fuel leaks into an inadequately ventilated space can lead to explosive accumulations of gas. Natural gas rises when released into the air and can accumulate under overhanging hoods and inside housings and buildings. LPG sinks when released into the air and can accumulate inside housings, basements and other below-grade spaces. Precautions must be taken to prevent gas leaks and the accumulation of gaseous fuel in the event of a leak.*

Check Gas Leaks and Correct

All fuel-system connections, including the container with associated valves and fittings, must be tested for leaks with a soap and water solution or equivalent, while the system is under pressure. LP gas pressure should not be less than 90 psi (621 kPa) at the inlet of the primary regulator for this test.

EXHAUST SYSTEM

⚠WARNING *Inhalation of exhaust gases can result in severe personal injury or death. Do not use exhaust heat to warm a room, compartment or storage area.*

Pipe exhaust gases to the outside of any enclosure. Locate the exhaust outlets away from any air inlets to avoid gases re-entering the enclosure. Exhaust installations are subject to various detrimental conditions such as extreme heat, infrequent operation and light loads. Regularly inspect the exhaust system both visually and audibly to see that the entire system remains fume tight and safe for operation.

⚠WARNING *Inhalation of exhaust gases can result in severe personal injury or death. Use extreme care during installation to provide a tight exhaust system. Terminate exhaust pipe away from enclosed or sheltered areas, windows, doors and vents.*

For indoor installation, the exhaust system must use sealed joint type fittings, (for example NPT fittings) to provide a tighter exhaust system. Use of slip type fittings (secured with a muffler clamp) may allow leakage of exhaust gases into the building.

⚠WARNING *Inhalation of exhaust gases can result in severe personal injury or death. Use extreme care during installation to provide a tight exhaust system. Use NPT or equivalent type fittings for all indoor installations.*

Use an approved thimble (Figure 4-1) where exhaust pipes pass through wall or partitions. Insulated wall/roof thimbles are used where exhaust pipes pass through a combustible roof or wall. This includes structures, such as wood framing or insu-

lated steel decking, etc. Uninsulated wall/roof thimbles are used where exhaust pipes pass through a non-combustible wall or roof, such as concrete. Refer to NFPA 37, Section 6-3. "Stationary Combustion Engines and Gas Turbines" for accepted design practices. Build according to the code requirements in effect at the installation site.

⚠WARNING *Hot exhaust pipes can start a fire and cause severe injury or death if improperly routed through walls. Use an approved thimble where exhaust pipes pass through walls or partitions.*

Rain caps are available for the discharge end of vertical exhaust pipes. The rain cap clamps onto the end of the pipe and opens due to exhaust discharge force from the generator set. When the generator set is stopped, the rain cap automatically closes, protecting the exhaust system from rain, snow, etc.

Use a section of flexible exhaust pipe between the engine and remainder of exhaust system. Support exhaust system to prevent weight from being applied to engine exhaust outlet.

⚠CAUTION *Weight applied to the engine manifold can result in damage. Support the muffler and exhaust piping so no weight or stress is applied to engine exhaust.*

The exhaust system design should meet local code requirements.

Liability for injury, death, damage, and warranty expense due to use of unapproved mufflers or modifications to the exhaust system becomes the responsibility of the person installing the unapproved muffler or performing the modification. Contact a Cummins Power Generation distributor for approved exhaust system parts.

Avoid sharp bends by using sweeping, long radius elbows and provide adequate support for muffler and tailpipe. Pitch a horizontal run of exhaust pipe DOWNWARD (away from engine) to allow any moisture condensation to drain away from the engine. If an exhaust pipe must be turned upward, install a condensation trap at the point where the rise begins (Figure 4-2).

Shield or insulate exhaust lines if there is danger of personal contact. Allow at least 12 inches (305 mm) of clearance if the pipes pass close to a combustible wall or partition. Before installing insulation on exhaust system components, check the exhaust system for leaks while operating the genset under full load and correct all leaks.

⚠ WARNING Exhaust pipes are very hot and they can cause severe personal injury or death from direct contact or from fire hazard. Shield or insulate exhaust pipes if there is danger of personal contact or when routed through walls or near other combustible materials.

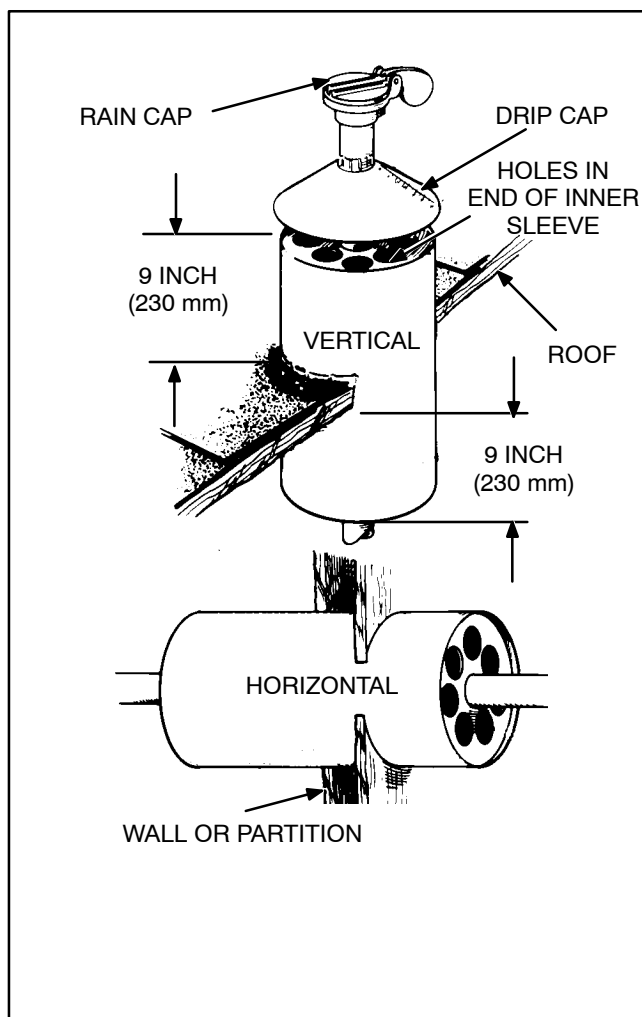

FIGURE 4-1. MOUNTING EXHAUST THIMBLE

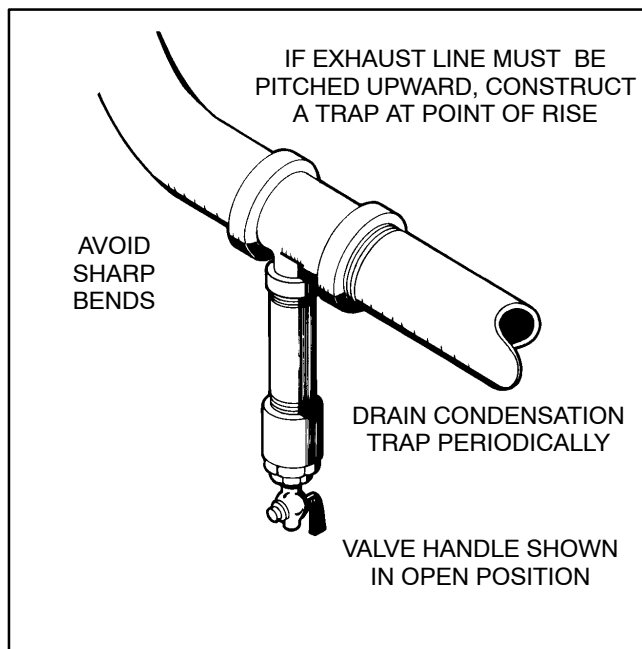

FIGURE 4-2. CONDENSATION TRAP

VENTILATION AND COOLING

Generator sets dissipate heat and fumes that must be removed by proper cooling and ventilation.

Generator sets in factory-mounted housings for outdoor installation are designed for proper cooling and ventilation.

Indoor installations require careful design with respect to cooling and ventilation. In an indoor installation, all radiator cooling air must be discharged to the out-of-doors. Duct adapter kits are available.

⚠WARNING *Engine or radiator cooling air may carry deadly carbon monoxide gas which can cause asphyxiation and death. All engine or radiator cooling air must be discharged to the out-of-doors. Do not use it for heating a room or compartment.*

Vents and Ducts

For indoor installations, locate vents so incoming air passes through the immediate area of the installation before exhausting. Install the air outlet higher than the air inlet to allow for convection air movement.

Size the vents and ducts so they are large enough to allow the required flow rate of air. The "free area" of ducts must be as large as the exposed area of the radiator. Refer to the genset *Data Sheet* for the air-flow requirements and allowed airflow restriction.

Wind will restrict free airflow if it blows directly into the air outlet vent. Locate the outlet vent so the effects of wind are eliminated. See Figure 4-3.

Dampers

Dampers or louvres protect the generator set and equipment room from the outside environment. Their operation of opening and closing should be controlled by operation of the generator set.

Designers should be aware that the generator set room operating temperature will be very close to the outdoor temperature, and either not route water piping through the generator set room, or protect it from freezing.

A thermostatically controlled recirculating damper in the radiator discharge duct may be used to reduce the volume of cold air drawn into the generator room.

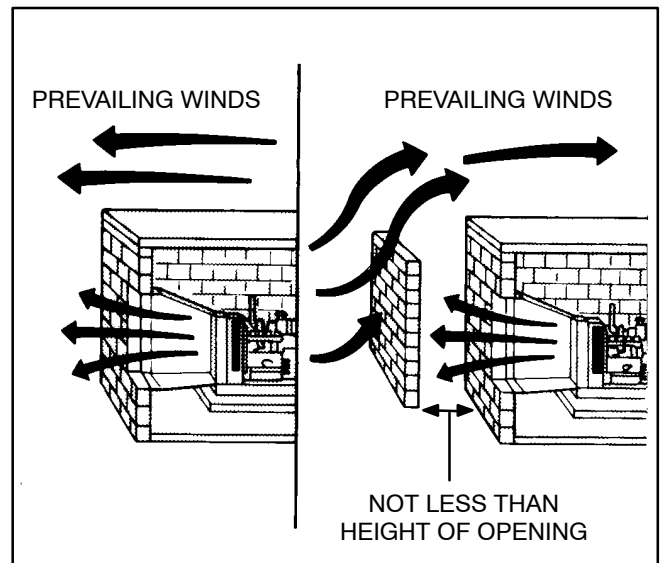

FIGURE 4-3. WIND BARRIER

Radiator Set Requirements

Louvers and screens over air inlet and outlet openings restrict air flow and vary widely in performance. A louver assembly with narrow vanes, for example, tends to be more restrictive than one with wide vanes. The effective open area specified by the louver or screen manufacturer should be used.

Radiator set cooling air is drawn past the control end of the set by a pusher fan that blows air through the radiator. Locate the air inlet to the rear of the set. Make the inlet vent opening 1-1/2 times larger than the radiator area.

Locate the cooling air outlet directly in front of the radiator and as close as possible. The outlet opening must be at least as large as the radiator area. Length and shape of the air outlet duct should offer minimum restriction to airflow.

Attach a canvas or sheet metal duct to the air outlet opening using screws and nuts so duct can be re-

moved for maintenance purposes. The duct prevents recirculation of heated air. Before installing the duct, remove the radiator core guard.

Remote Radiator Cooling (Optional) substitutes a remote mounted radiator and an electrically driven fan in place of genset mounted components. Removal of the radiator and the fan from the genset reduces noise levels without forcing dependence on a continuous cooling water supply (necessary with heat exchanger cooling). The remote radiator installation must be completely protected against freezing.

Remote radiator plumbing will vary with installation. Follow recommendations given in Application Manual T-030. See product *Data Sheet* for friction head and static head limits.

Before filling cooling system, make sure all hardware is tight. This includes hose clamps, capscrews, fittings and connections. Use flexible coolant lines with heat exchanger or remote mounted radiator.

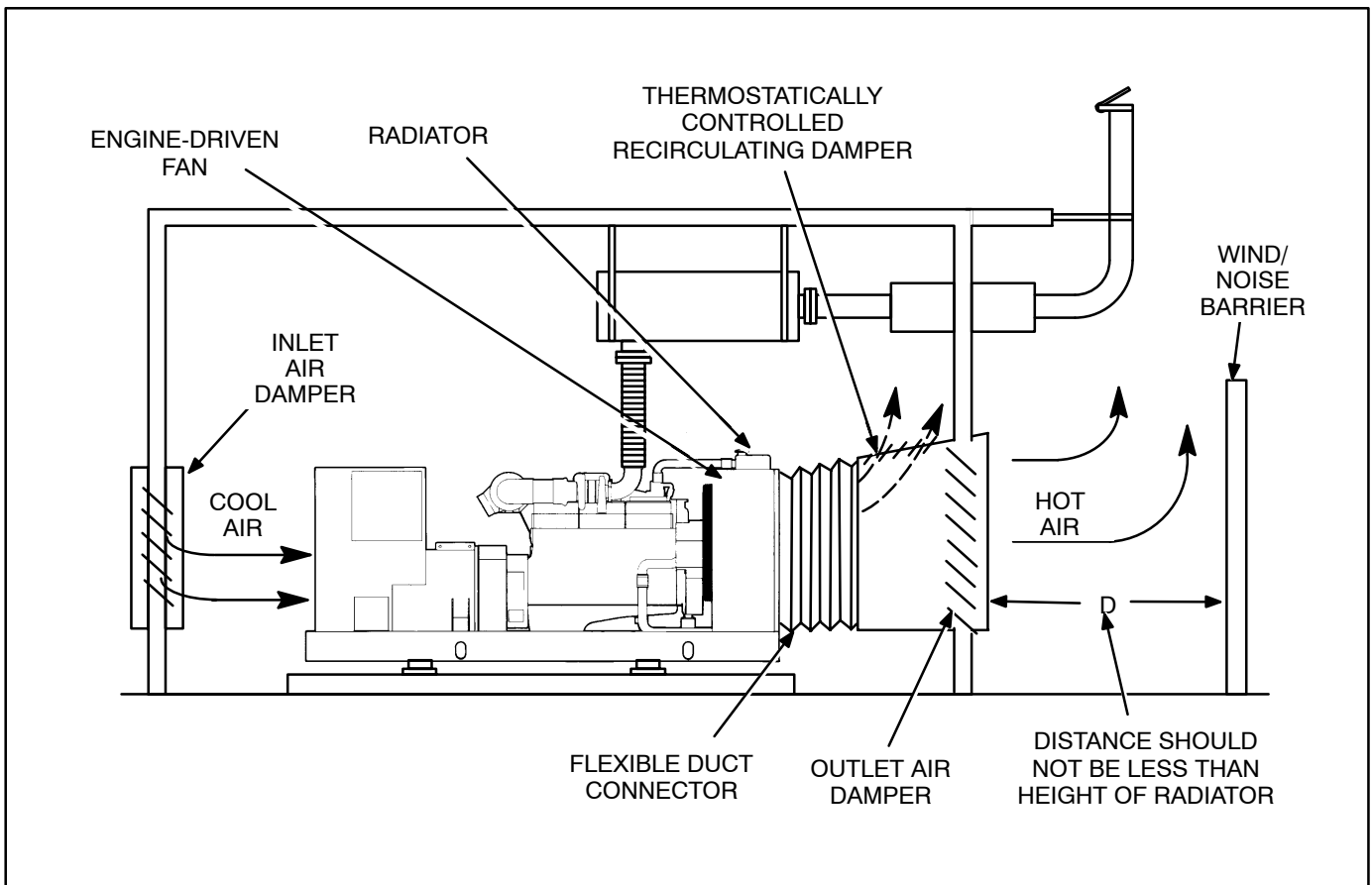

FIGURE 4-4. TYPICAL RADIATOR SET INSTALLATION

5. DC Control Wiring

CONTROL WIRING

The generator set control box contains connection points for remote control and monitor options. These connection points are located inside of the control box (Figure 5-1).

Use flexible conduit for all wiring connections to the generator set.

CAUTION *Stranded copper wire must be used for all customer connections to the control panel. Solid copper wire may break due to genset vibration.*

WARNING *HAZARDOUS VOLTAGE Touching uninsulated high voltage parts inside the control box can result in severe personal injury or death. Control wire installation must be done with care to avoid touching uninsulated live parts.*

Stand on a clean dry wooden platform or clean rubber insulating mat, make sure your clothing and shoes are dry, remove jewelry and use tools with insulated handles.

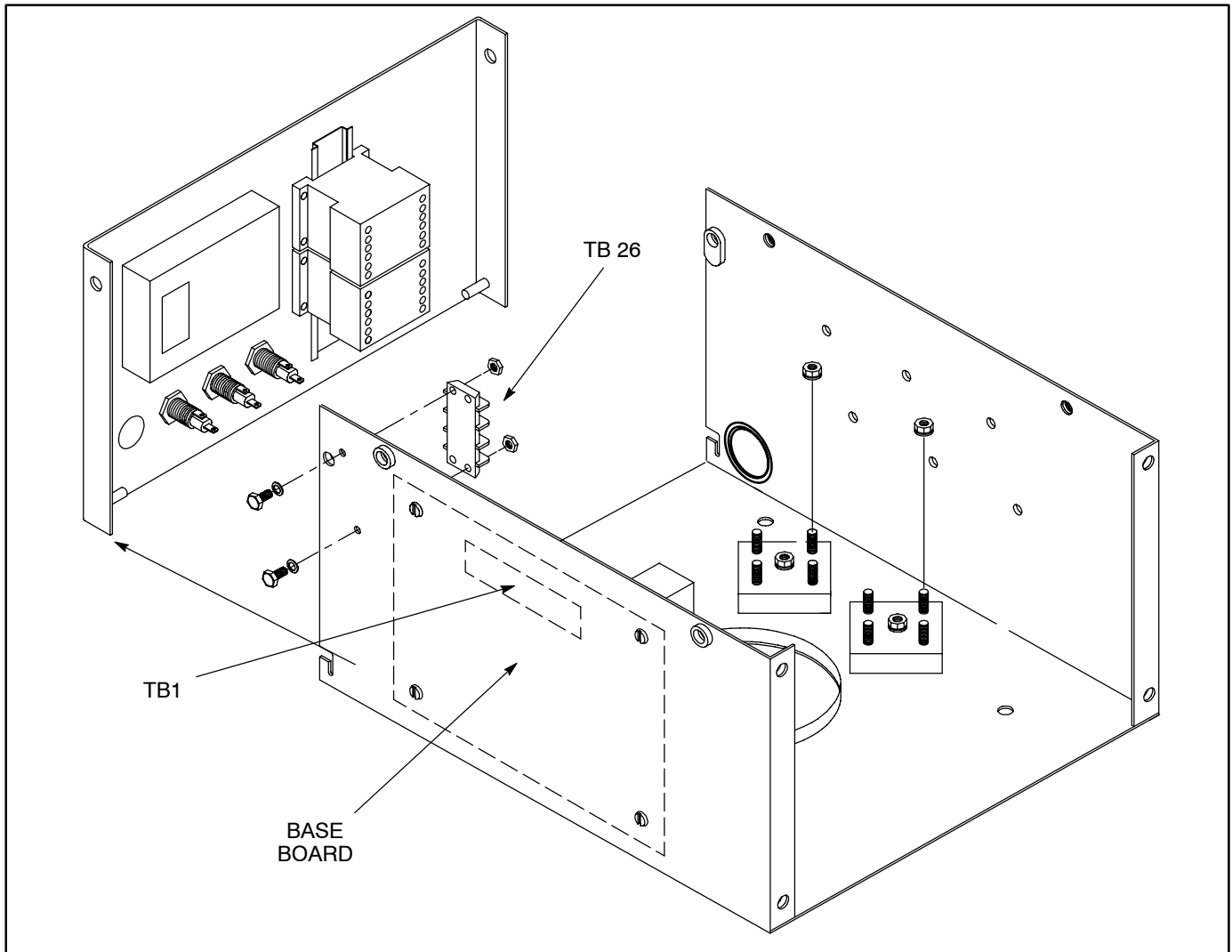

FIGURE 5-1. CONTROL BOX

TB1 REMOTE MONITOR/CONTROL CONNECTIONS

Customer monitor/control connections are attached to terminal block TB1 (Figure 5-1). Optional equipment, such as sensing devices used to monitor genset operation, remote start/stop switches, etc. are attached to TB1. Refer to Customer Connections diagram in Section 9.

Available options will vary between PCC1301 control models (PCC with or without display).

TB1 Wiring

CAUTION Always run control circuit wiring in a separate metal conduit from AC power cables to avoid inducing currents that could cause problems within the control.

Digital Connections: Connection points, other than relayed outputs and network are considered digital connections to terminal strip TB1. The type/gauge wire to use for these connections are:

- Less than 1000 feet (305m), use 20 gauge stranded copper wire.
- 1000 to 2000 feet (305 to 610m), use 18 gauge stranded copper wire.

Relay Connections: Due to the wide variety of devices that can be attached to the relay outputs of TB1, the electrical contractor must determine the gauge of the **stranded copper** wire that is used at this installation site.

TB1 Customer Inputs

Refer to Page 9-1 for typical connections to TB1.

Remote Start: When the control is in Auto/Remote mode, grounding this input initiates the engine cranking and start sequence. This circuit must be opened to permit resetting a shutdown condition with the Reset input. (The remote stop is actually the removal of the remote start signal to the control.)

Remote Emergency Stop: Opening this input causes an immediate shutdown. Emergency stop must be reset at the front panel.

Customer Fault Inputs 1 and 2: Grounding any one of these inputs activates the corresponding warning or shutdown sequence.

External sensing equipment must be connected to the designated digital input.

The nature of the fault is an optional customer selection. Example inputs: Low Coolant Level, Low Fuel Pressure, Ground Fault, etc.

Each of the two fault functions can be programmed as follows:

- Status, Warning or Shutdown. Default = Warning.
- Enter a brief description of the event (up to 32 characters).

The InPower service tool or access to the Setup Submenus is required to modify the customer fault inputs. Contact an authorized service center for assistance.

TB1 Customer Outputs

Refer to Page 9-1 for typical connections to TB1.

Customer Outputs 1 and 2: One set of normally open (NO) contacts, rated for 2 amps at 30 VDC for each of the two output signals. The relays can be used to control small devices and indicator lamps.

The nature of the customer output signal (contacts closed) is an optional customer selection. Example outputs: Genset running (event), common warning, common shutdown, etc. (Refer to Operator's manual for warning and shutdown code listing and the Service manual for event code listing.)

Each relay can be independently programmed to energize by entering a code number (0 through 255, default = 0) for the desired event.

The InPower service tool or access to the Setup Submenus is required to modify the customer outputs. Contact an authorized service center for assistance.

Ready To Load Signal (Generator Set Running): B+ signal out when the generator set has reached 90 percent of rated speed and voltage.

SWITCHED B+

Switched B+ (T26) has six terminals located in the control box and is fused at 20 amps.

UNIVERSAL ANNUNCIATOR

The optional universal annunciator (300-5929) provides for remote monitoring of the power system. Refer to its operators manual for connections.

I/O MODULE

The optional I/O module provides additional customer inputs and outputs for control and monitoring of the power system. Up to sixteen relay outputs and twelve discrete analog inputs are available when the control contains both the Base I/O Module (AUX101) and the Expansion I/O Module (AUX102). Refer to Instruction Sheet C693 for I/O module configuration/wiring information.

RUN RELAYS (K10, K11)

The optional run relays (Figure 5-2) are mounted inside the control box. They are used to control auxiliary equipment such as fans, pumps and motorized air dampers. The run relays are energized when the generator set control receives a start signal.

The contacts are rated:

- 20 amps resistive @ 30VDC
- 15 amps inductive @ 30VDC

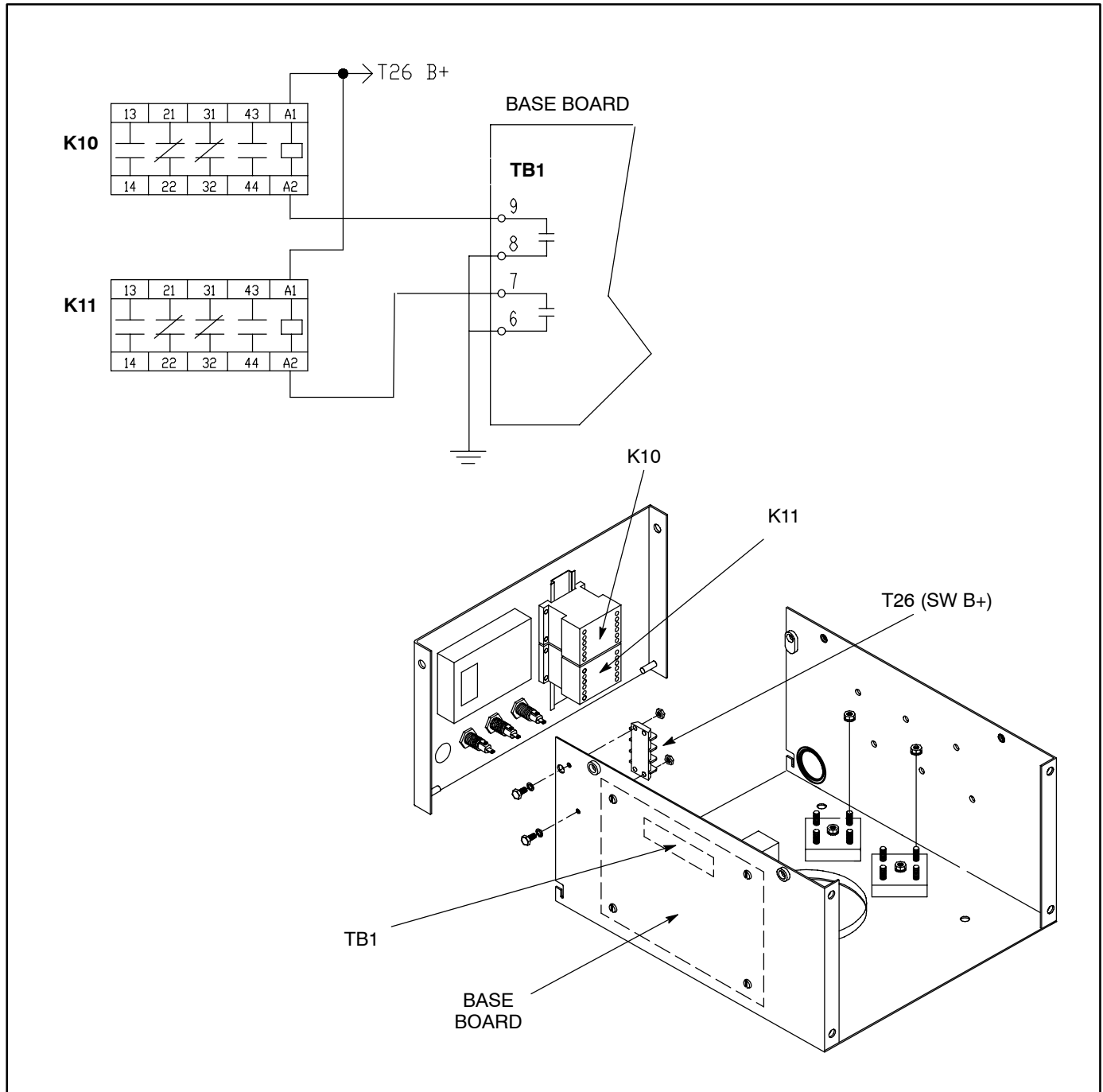

FIGURE 5-2. OPTIONAL RUN RELAYS (K10, K11)

BATTERIES

The generator set has a 12 VDC, negative-ground control and starting system. See Figure 5-3 for battery cable connections and *Specifications* for minimum battery requirements.

The engine is equipped with a 45 amp battery charging alternator to supply the control loads and restore cranking current. Emergency standby applications will require a battery charger powered by the normal AC power supply. Check the local codes for emergency standby requirements.

The generator set is provided with battery cables and the skid-base has a built-in battery rack.

⚠WARNING *Accidental starting can cause severe personal injury or death. Push the control panel switch to OFF before connecting the battery cables.*

⚠WARNING *Arcing can ignite battery gases and cause severe personal injury and can cause voltage spikes that can damage generator set control circuits. To reduce arcing:*

Always disconnect a battery charger from its AC source before disconnecting the battery cables.

Always disconnect the negative (-) cable first and reconnect it last. (This prevents arcing if the tool on the positive terminal touches grounded metal.)

⚠CAUTION *The battery must be of a type with barbed vent hose fittings for its cells. The vent lines must be routed away from the generator end bell (air inlet) to prevent battery gases from entering the generator and causing corrosion.*

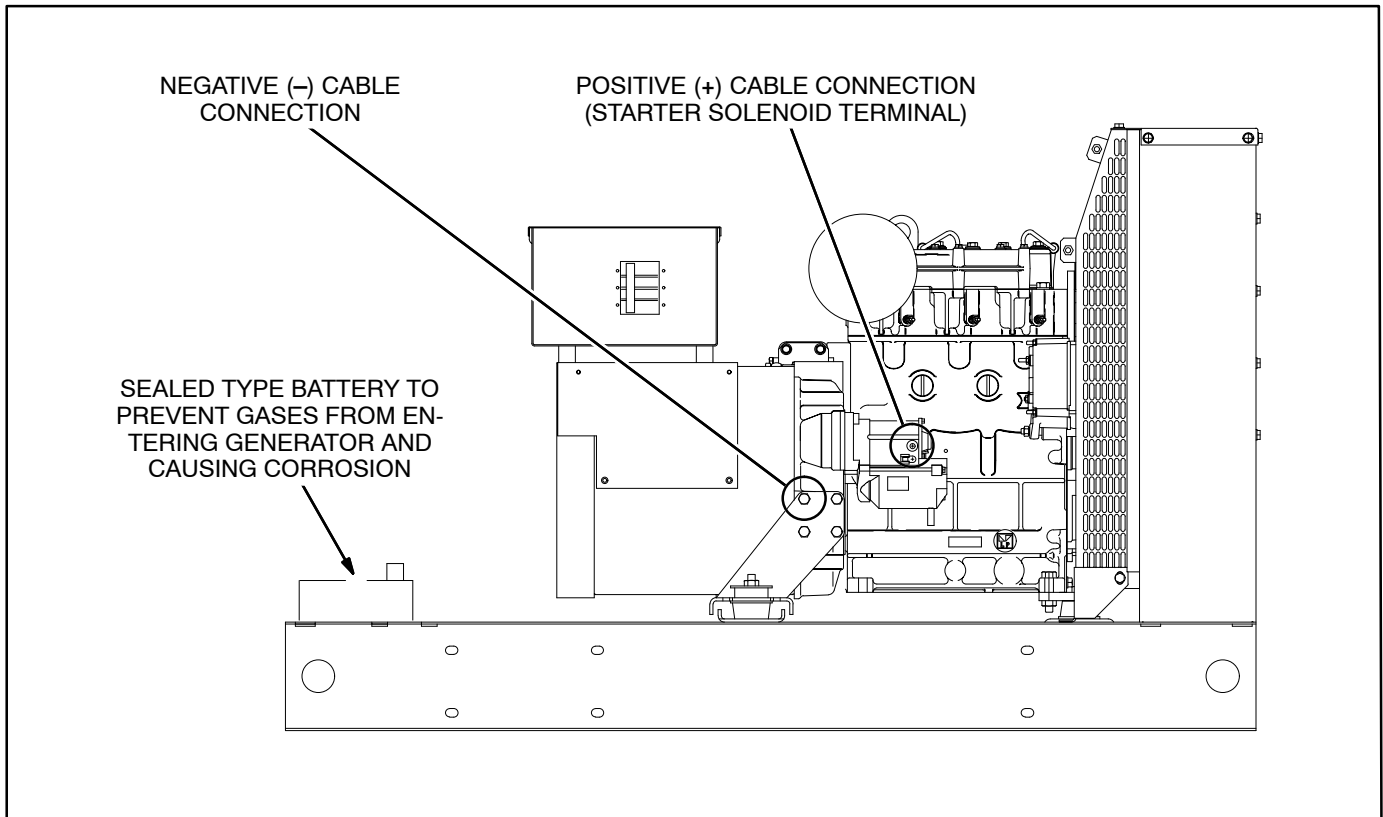

FIGURE 5-3. BATTERY CONNECTIONS

6. AC Electrical Connections

GENERAL

This section provides the procedure that is used to connect the AC electrical system of the genset.

Before making any AC electrical connections, make certain the generator set cannot be accidentally started. Place the control panel run switch in the OFF position. Turn off or remove AC power from the battery charger and then remove the negative (–) battery cable from the set starting battery.

⚠WARNING *Ignition of explosive battery gases can cause severe personal injury or death. Arcing at battery terminals, light switch or other equipment, flame, pilot lights and sparks can ignite battery gas. Do not smoke, or switch trouble light ON or OFF near battery. Discharge static electricity from body before touching batteries by first touching a grounded metal surface.*

Ventilate battery area before working on or near battery—Wear goggles—Stop genset and disconnect charger before disconnecting battery cables—Disconnect negative (–) cable first and reconnect last.

⚠CAUTION *Disconnect battery charger from AC source before disconnecting battery cables. Otherwise, disconnecting cables can result in voltage spikes damaging to DC control circuits of the set.*

⚠WARNING *Accidental starting of the generator set can cause severe personal injury or death. Prevent accidental starting by disconnecting the negative (–) cable from the battery terminal.*

⚠WARNING *Each of the operations described in this section should be done only by persons trained and experienced in electrical maintenance. Improper procedures may result in property damage, bodily injury or death.*

Connecting the genset AC electrical system involves:

- Installation of transfer switch
- Generator output voltage selection
- Load cable connection
- Standard and optional AC equipment connections (e.g., control box heater, coolant heater, etc.).

Local regulations often require that wiring connections be made by a licensed electrician, and that the installation be inspected and approved before operation. All connections, wire sizes, materials used, etc. must conform to the requirements of electrical codes in effect at the installation site.

⚠WARNING *Improper wiring can cause a fire or electrical hazard, resulting in severe personal injury or death and/or property and equipment damage.*

Before starting the genset, check to make sure that all electrical connections are secure, and that all wiring is complete. Replace and secure any access panels that have been removed during installation. Check that the load cables from the genset are properly connected.

⚠WARNING *Backfeed to utility system can cause electrocution or property damage. Do not connect to any building electrical system except through an approved device and after building main switch is opened.*

TRANSFER SWITCH

If the installation is for standby service, a transfer switch must be used for switching the load from the normal power source to the genset (see Figure 6-1). Follow the installation instructions provided with the transfer switch when connecting the load and control wiring.

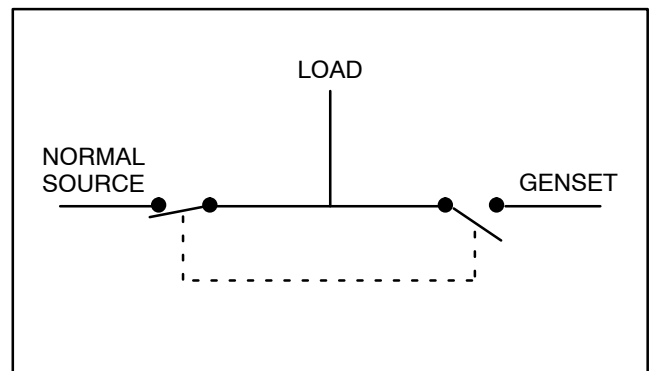

FIGURE 6-1. TYPICAL LOAD TRANSFER FUNCTION

AC WIRING

Generator Voltage Connections

The available generator output voltages and maximum current ratings are specified on the generator set nameplate. Line-to-neutral voltage is always the lower voltage shown and line-to-line voltage is the higher rating.

These generators can be configured to the nameplate voltages as shown on the Reconnection Diagram decal, attached to the backside of the control box cover. Many of the voltages listed will require reconfiguration of the generator output leads on the connection terminal block. This reconfiguration must only be done by service personnel that are trained and experienced to perform electrical installation. The generator set was adjusted to produce a specified voltage during production verification testing prior to shipment. The installer must always check the stator lead terminal block connections and perform any necessary reconnect to obtain the voltage required.

Some generator sets are capable of producing a wide range of voltages and connection configurations, others have specific limited capabilities. Refer to wiring diagram and generator voltages (from the nameplate) when reviewing the voltage connection information and use the wiring diagram supplied with your generator set when actually performing load connections.

⚠ CAUTION *Reconfiguring generator sets to higher voltages can exceed the voltage capability of the specific generator windings and damage the generator and also decrease line current, rendering line circuit breakers too large. Consult with your distributor before performing reconnection for a different voltage.*

⚠ CAUTION *Reconfiguring generator sets to lower voltages can reduce generator set ratings, and also increase line current, rendering line circuit breakers too small. Consult with your distributor before performing reconnection for a different voltage.*

Load Connections

Flexible conduit and stranded conductors must be used for connections to take up movement of the generator set.

All loads are connected to the generator by bolting **stranded** load wires to the appropriate terminals on the generator reconnection terminal block or circuit breaker lugs. The terminals are marked U, V, W and N to indicate the line and neutral connections. (Reference: U, V, and W correspond with L1, L2 and L3; and N with L0 respectively).

Load Balancing

When connecting loads to the generator set, bal-

ance the loads so the current flow from each line terminal (L1, L2 and L3) is about the same. This is especially important if both single phase and three phase loads are connected. Any combination of single phase and three phase loading can be used as long as each line current is about the same, within 10 percent of median value and no line current exceeds the nameplate rating of the generator. Check the current flow from each line after connections by observing the control panel ammeter.

Current Transformers (Optional)

The optional current transformers (CTs) are used to display genset load in kVA and alternator amperage. Refer to the Reconnection Diagram for routing leads through the CTs.

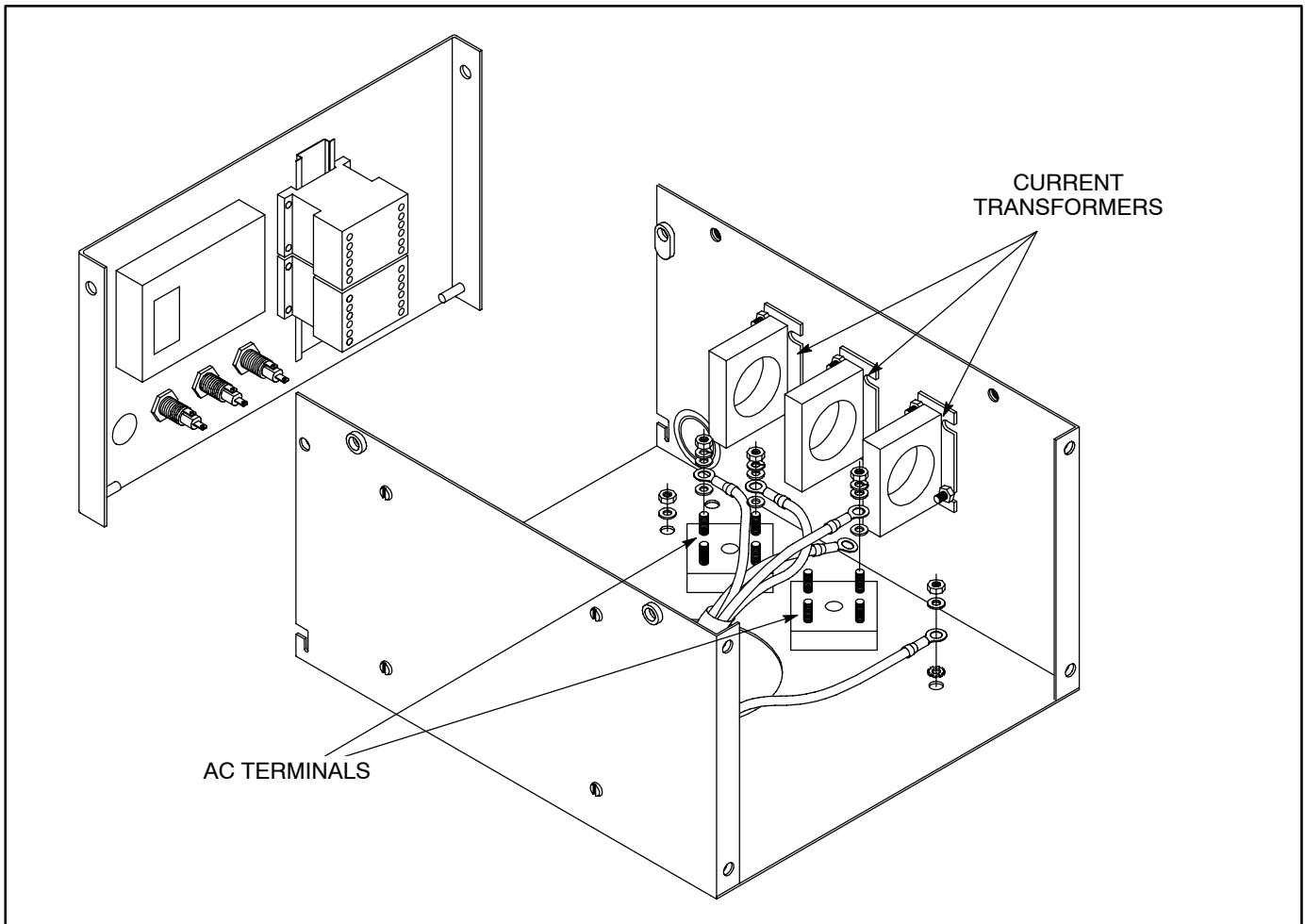

FIGURE 6-2. AC OUTPUT BOX

Grounding

The following is a brief description of system and equipment grounding of permanently installed AC generators within a facility wiring system. It is important to follow the requirements of the local electrical code.

Figure 6-3 illustrates typical system grounding for a 3-pole and a 4-pole automatic transfer switch (ATS). In the 3-pole ATS, note that the generator neutral is connected to the ATS and is NOT bonded to ground at the generator. In the 4-pole ATS system, a grounding electrode conductor and a bonding jumper are used to connect the generator neutral to ground.

Make sure the genset is grounded to earth in one location only. Use the ground lug provided in the power output box.

⚠WARNING *Electric current can cause severe personal injury or death. Bonding and grounding must be done properly. All metallic parts that could become energized under abnormal conditions must be properly grounded.*

Typical requirements for bonding and grounding are given in the National Electrical Code, Article 250. All connections, wire sizes, etc. must conform to the requirements of the electrical codes in effect at the installation site.

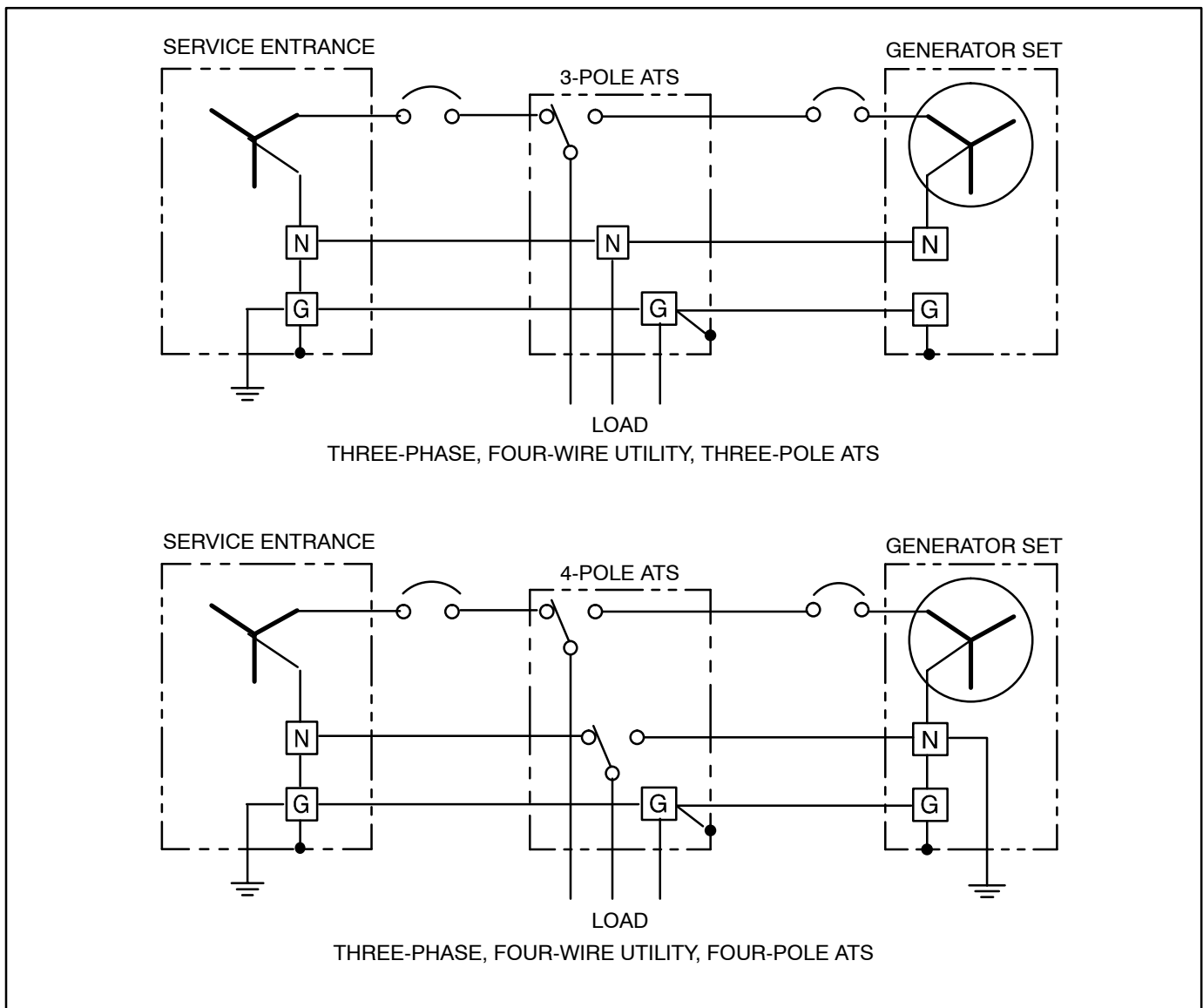

FIGURE 6-3. TYPICAL SYSTEM GROUNDING ONE-LINE DIAGRAMS

CONTROL HEATER (OPTIONAL)

A control heater (Figure 5-4) provides a means of humidity / temperature control of the control box interior. It protects the components when the generator set is subjected to varying ambient air conditions during extended periods of non-use.

The heater is equipped with a power cord that terminates with a 120V or 240V NEMA plug.

COOLANT HEATER (OPTIONAL)

A coolant heater is used to keep the engine coolant warm when the engine is shut down. It heats and circulates the coolant within the engine. This reduces startup time and lessens engine wear caused by cold starts. It is electrically operated and thermostatically controlled.

⚠WARNING *The coolant heater must not be operated while the cooling system is empty or damage to the heater will occur.*

The heater is equipped with a power cord that terminates with a 120V or 240V NEMA plug.

Connect the heater to a source of power that will be on during the time the generator set is not running. Be sure the voltage rating is correct for the heater element rating.

GENERATOR HEATER (OPTIONAL)

A generator heater is used to help keep the generator free of condensation when the generator set is not running. During cool and humid conditions, condensation may form within a generator, creating flashing and shock hazards.

⚠WARNING *Water or moisture inside a generator increases the possibility of flashing and electrical shock, which can cause equipment damage and severe personal injury or death. Do not use a generator which is not dry inside and out.*

The heater is equipped with a power cord that terminates with a 120V NEMA plug.

Connect the heater to a source of power that will be on during the time the generator set is not running.

7. Prestart Preparation

GENERAL

Before attempting the initial start of the generator set, be sure to complete the *Installation Checklist* in *Section 8*.

INPOWER SERVICE TOOL GENERAL INFORMATION

InPower is a PC based service tool for the PowerCommand® 1301 Control (PCC). Use InPower to:

- Make adjustments to the controls trims and settings.
- Perform diagnostics and monitoring.
- Create a capture file of the controls trims and settings.
- Update control calibrations (InPower PRO version).

Refer to INPOWER User's Guide for specifics.

InPower Adjust Mode

The adjustment feature allows you to make adjustments to genset parameters, calibrations and settings. There are several groups of adjustment parameters; note that not all gensets will have the same adjustments available.

InPower Capture File Description

InPower provides a method of extracting (capturing) a device's parameter values. Capturing saves device information in a file that is identified with a .CAP extension.

Capture files are used to store a copy of the genset's parameter values. During genset installation, it is suggested that a capture file be made before and after changes are made to the genset operating parameters. This information can be a very useful

when troubleshooting the genset (determine if parameters/settings have been modified after installation) and when replacement of the Base board is necessary. The capture file can be used as a template to write the previous settings to the new Base board software.

ELECTRICAL SYSTEM

Verify all electrical connections are secure and all wiring is complete and inspected. Replace and secure any access panels that may have been removed during installation.

Battery Connections

⚠WARNING *Accidental starting of the generator set can cause severe personal injury or death. Make sure that the PCC is in the OFF mode before connecting the battery cables.*

Starting the unit requires a 12 volt battery. Connect positive battery cable before connecting negative battery cable to prevent arcing.

Service the batteries as necessary. If an automatic transfer switch is installed without a built-in charge circuit, connect a separate battery charger. Proper selection and maintenance of batteries and battery chargers is essential for system reliability.

⚠WARNING *Ignition of explosive battery gases can cause severe personal injury or death. Always connect negative (-) battery cable last to prevent arcing.*

⚠WARNING *Ventilate battery area before working on or near battery. Arcing at battery terminals, light switch or other equipment, flame, pilot lights and sparks can ignite battery gas. Do not smoke, or switch trouble light ON or OFF near battery. Discharge static electricity from body before touching batteries by first touching a grounded metal surface.*

PCC OPTIONS PRESTART CHECKS

All generator set configuration options are set at the factory except for site related options, (e.g., Start/Stop Time Delays, Cycle Crank, Customer Fault 1 and 2, etc.

If the PCC graphical display option is not provided, the InPower service tool will be required to adjust all site related options.

Adjustment of these options are divided into two categories within the menu driven system. These two categories are *Setup* and *Screen Adjust*.

The *Setup* menus are intended for qualified service personnel only and require a password to modify these submenus (refer to *Service* manual). The *Screen Adjust* menu is intended for service personnel and site personnel.

SCREEN ADJUST MENU

Figure 7-1 shows a block representation of the Screen Adjust menu. The Screen Adjust menu is displayed when the **(3)** button is pressed in the first Service Menu.

From any of the Operator menus, simultaneously press the ▲ and ▼ selection buttons for two seconds to display the first Service menu.

Adjusting Values/Parameters

1. Press the **ADJUST** selection button to select the first parameter or value to be changed.
2. Press the + or – selection buttons to adjust values or select parameters.
3. Press the arrow selection button → to navigate to the next or previous adjustable value or parameter.
4. After adjusting values/selecting parameters, press the **SAVE** button to save your settings.

NOTE: If the Previous Menu button ◀ is pressed before pressing the SAVE button, the changes are not saved.

5. Press the ◀ button to return to the Service Menu.

Screen Adjust Menu

This menu allows for adjusting the screen's contrast and brightness and for selecting the units of measurement (SAE or SI) to be displayed.

- *Contrast and Brightness:* Press the + or – selection buttons to adjust the screen's contrast and brightness. Changing the brightness setting also affects the brightness of the LEDs on the control panel.
- *Units:* Press the + or – selection buttons to select SAE (°F, PSI) or SI (C, kPa) units of measurement to be displayed.

SCREEN ADJUST MENU

ADJUST
SCREEN

Contrast

Brightness

Units: °F, PSI

ADJUST

ADJUST
SCREEN

Contrast

Brightness

Units: C, kPa

SAVE | → | - | +

FIGURE 7-1. SCREEN ADJUST MENU

STARTING

Refer to the generator set *Operator's* manual for important safety precautions and recommended procedures for starting the genset and verifying proper operation. Start the generator set and verify all engine and generator menus are displaying the correct values.

8. Installation Checklist

GENERAL

- Generator set wattage capacity is sufficient to handle maximum anticipated load.
- At least 3 feet of clearance (or greater for housing door) is provided around entire generator set for servicing and ventilation.
- Generator set is located in an area not subject to flooding.
- All operating personnel have read and are familiar with Operator's Manual.
- All operators have been thoroughly briefed on preventive maintenance procedures.
- All operators have read and understand all Important Safety Instructions in Operator's Manual.

GENERATOR SET SUPPORT

- Floor, roof or earth on which the generator set rests is strong enough and will not allow shifting or movement. Observe local codes on soil bearing capacity due to freezing and thawing.
- Generator set is properly supported and retained to approved base.
- Supporting base is large enough and is of non-combustible material – extends 6-inches all around set.

COOLING AIR FLOW

- Generator set air inlet is faced into direction of strongest, prevailing winds.
- Air inlet openings are unrestricted and at least 1–1/2 times larger than air outlet area.
- Cooling air outlet is on downwind side of building (if not, wind barrier is constructed).
- Proper ducting material (sheet metal, canvas) is used between radiator and air outlet.

FUEL SYSTEM

- Fuel tanks meet or exceed all Local, State or National codes.
- Fuel lines are properly installed, supported and protected against damage.
- Approved flexible fuel line is installed between main fuel supply line and generator set's fuel system, near the generator set, to protect the fuel system from damage caused by vibration, expansion and contraction.
- Fuel supply line shutoff valves are installed to prevent fuel flow in case of leaks.
- No fuel leaks are found in supply line or engine fuel system.

EXHAUST SYSTEM

- Operators are thoroughly briefed on the dangers of carbon monoxide gas.
- Areas around set are well ventilated. No possibility of exhaust fumes entering building doors, windows, or intake fans.
- Exhaust gases are piped safely outside and away from building.
- The correct length of approved rigid pipe is connected to the generator set flexible pipe using approved securing methods with no weight resting on engine exhaust components. There are no bends in flex section.
- Condensation drain is provided in lowest section of exhaust piping.
- Exhaust piping is insulated to guard against burns to personnel.
- Exhaust piping passing through walls or ceilings have approved fire-proof materials and are in compliance with all codes.
- Exhaust piping is large enough in diameter to prevent excessive back pressure on engine.

AC AND DC WIRING

- Wire sizes, insulation, conduits and connection methods all meet applicable codes.
- AC and DC wires are separated in their own conduit to prevent electrical induction.
- All load, line and generator connections are proper and correct.
- Flexible conduit between generator set and building or surrounding structure.

GENERATOR SET PRESTART

- Generator set engine is properly serviced with oil and coolant.
- Batteries are properly installed, serviced and charged.
- Battery charger and engine coolant heater are connected and operational.
- All generator set covers and safety shields are installed properly.
- All fuel and coolant shutoff valves are operational.
- Created control capture file of the generator's set parameter values before and after modifications.

9. Wiring Diagrams

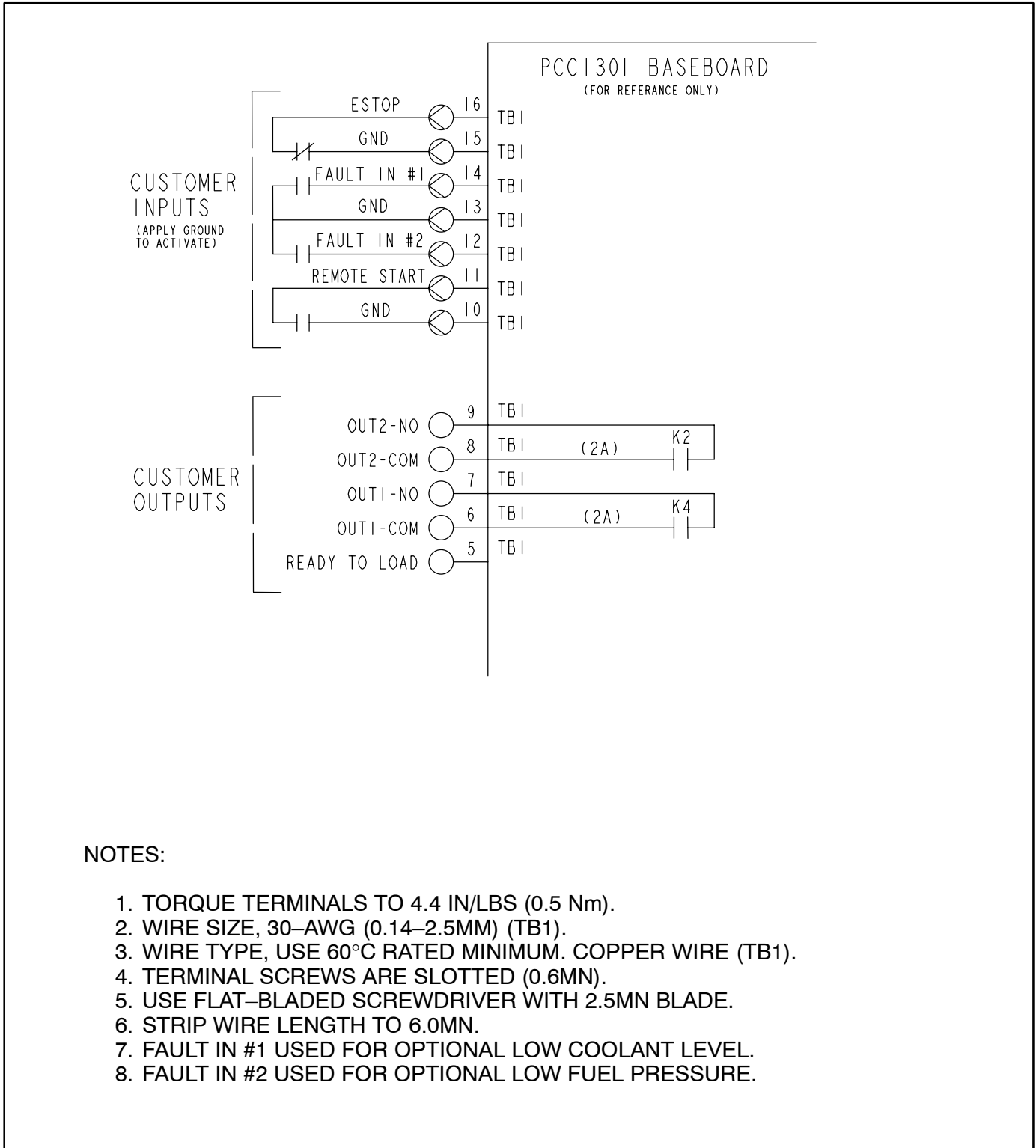

NOTES:

1. TORQUE TERMINALS TO 4.4 IN/LBS (0.5 Nm).
2. WIRE SIZE, 30-AWG (0.14-2.5MM) (TB1).
3. WIRE TYPE, USE 60°C RATED MINIMUM. COPPER WIRE (TB1).
4. TERMINAL SCREWS ARE SLOTTED (0.6MN).
5. USE FLAT-BLADED SCREWDRIVER WITH 2.5MN BLADE.
6. STRIP WIRE LENGTH TO 6.0MN.
7. FAULT IN #1 USED FOR OPTIONAL LOW COOLANT LEVEL.
8. FAULT IN #2 USED FOR OPTIONAL LOW FUEL PRESSURE.

CUSTOMER CONNECTION DIAGRAM

THIS PAGE LEFT INTENTIONALLY BLANK

Cummins Power Generation
1400 73rd Avenue N.E.
Minneapolis, MN 55432
1-800-888-6626
763-574-5000 International Use
Fax: 763-528-7229

Cummins is a registered trademark of Cummins Inc.

