

SECTION 4. REVOLVING FIELD GENERATORS

INDEX

REVOLVING FIELD GENERATORS	4-1
GENERAL	4-1
MAGNECITER	4-1
Troubleshooting	4-1
	4-3
	4-4
Testing	4-2
Automatic Field Flashing	4-7
Installing New Rectifiers	4-7
Exciter Voltage Test	4-7
MAINTENANCE AND ADJUSTMENTS	4-7
J-Series (Specs A Through Z)	4-7
Brushes	4-7
Repair	4-16
Troubleshooting	4-16
No-Voltage Buildup	4-16
Over-Voltage or Fluctuating Voltage	4-17
Generator Bearing	4-17
Collector Rings	4-17
Magneciter	4-17
Alternator Testing	4-17
Rotor Continuity	4-18
Stator Continuity	4-18
Battery Charging Windings	4-18
GENERATOR DISASSEMBLY	4-18
GENERATOR ASSEMBLY	4-19
TABLE 4-1. MAGNECITER TROUBLESHOOTING	4-3
	4-4
TABLE 4-2. EXCITER VOLTAGE VALUES	4-8
TABLE 4-3. VOLTAGE VALUES (Generator Running)	4-8
TABLE 4-4. EXCITER RESISTANCE VALUES	4-9
TABLE 4-5. MAGNECITER DIAGRAMS	4-10
	4-11
	4-12
	4-14
	4-15

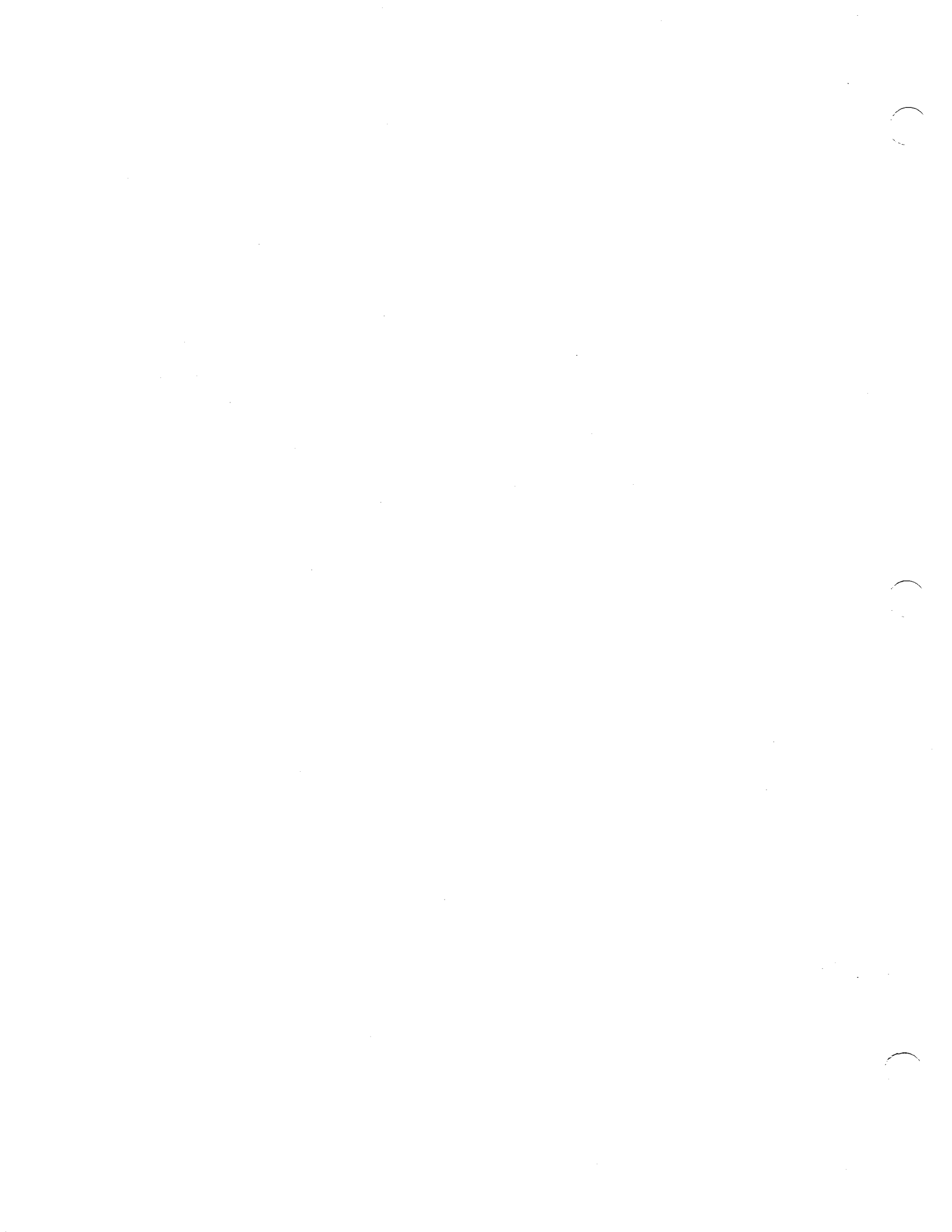

REVOLVING FIELD GENERATORS

GENERAL

Keeping in mind the material on revolving armature power generation in the preceding section we can now discuss revolving field generators.

Suppose instead of turning a coil of wire in the magnetic field rotated inside the coil. The result is a revolving field generator (Figure 4-1). The revolving field is the rotor and permanently fixed winding is the stator. With this type of generator there is no need for slip rings to transfer power from the stationary armature coils.

Slip rings are used to supply direct current to the electromagnetic field of the alternator. Onan generators use a static exciter, a non rotating device that converts AC output to DC and regulates current to the field. This static exciter is called a Magneciter (Figure 4-2).

The output frequency of the revolving field generator depends directly on its rotating speed. The voltage output of this generator is determined by rotating speed, number of turns in the stator, and the field strength by controlling the field current. The magneciter allows the adjusting of output voltage over a limited range - 3% at a steady speed - and has rapid recovery capabilities from a sudden load application or removal.

MAGNECITER DESCRIPTION, TROUBLESHOOTING, AND REPAIR.

The static exciter (Magneciter) supplies direct current to the alternator field coils and regulates the voltage produced by the alternator. Voltage stabilization occurs within two seconds after a change in load. Voltage regulation should be within ± 3 percent.

The Onan static exciter has no moving parts and consequently demands minimum maintenance. By periodically performing preventive maintenance (blowing dust from the unit using filtered, low pressure air), corrective maintenance will be virtually eliminated.

Corrective maintenance can be handled by anyone with a knowledge of basic electricity and with the proper equipment for applying that knowledge. Most troubleshooting can be accomplished with a multimeter or a battery operated volt-ohmmeter, and a 120-volt, 25-watt AC test lamp.

Troubleshooting

Troubles are listed in advancing order, from no output voltage to a rated but fluctuating output voltage. The relationship between trouble and cause is not always consistent from model to model, so the following information must be used as a guide, *not an absolute rule!* The column entitled "Method" indicates the method for testing a standard component. When the word "None" appears in that column, all the information needed to complete the check is given in the column headed "Corrective Action". When more than one letter appears in that column for a single action,

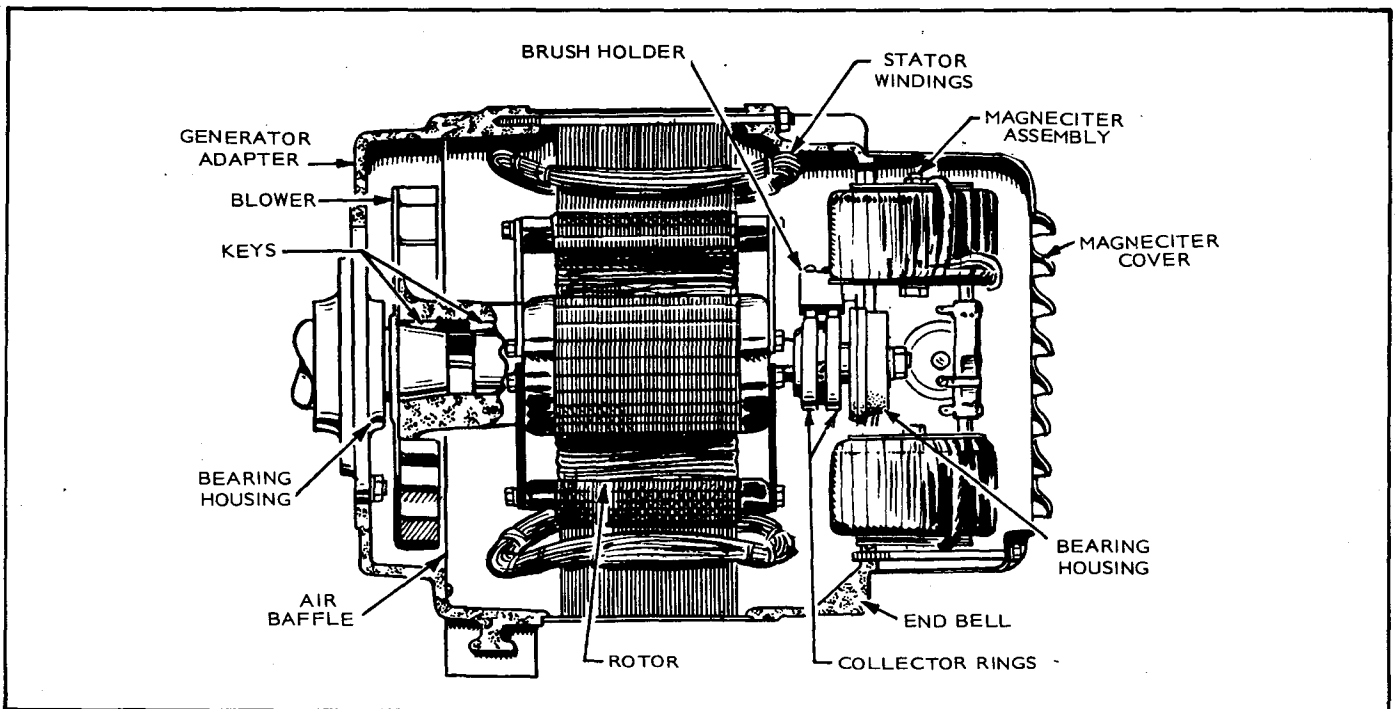

FIGURE 4-1. REVOLVING FIELD GENERATOR

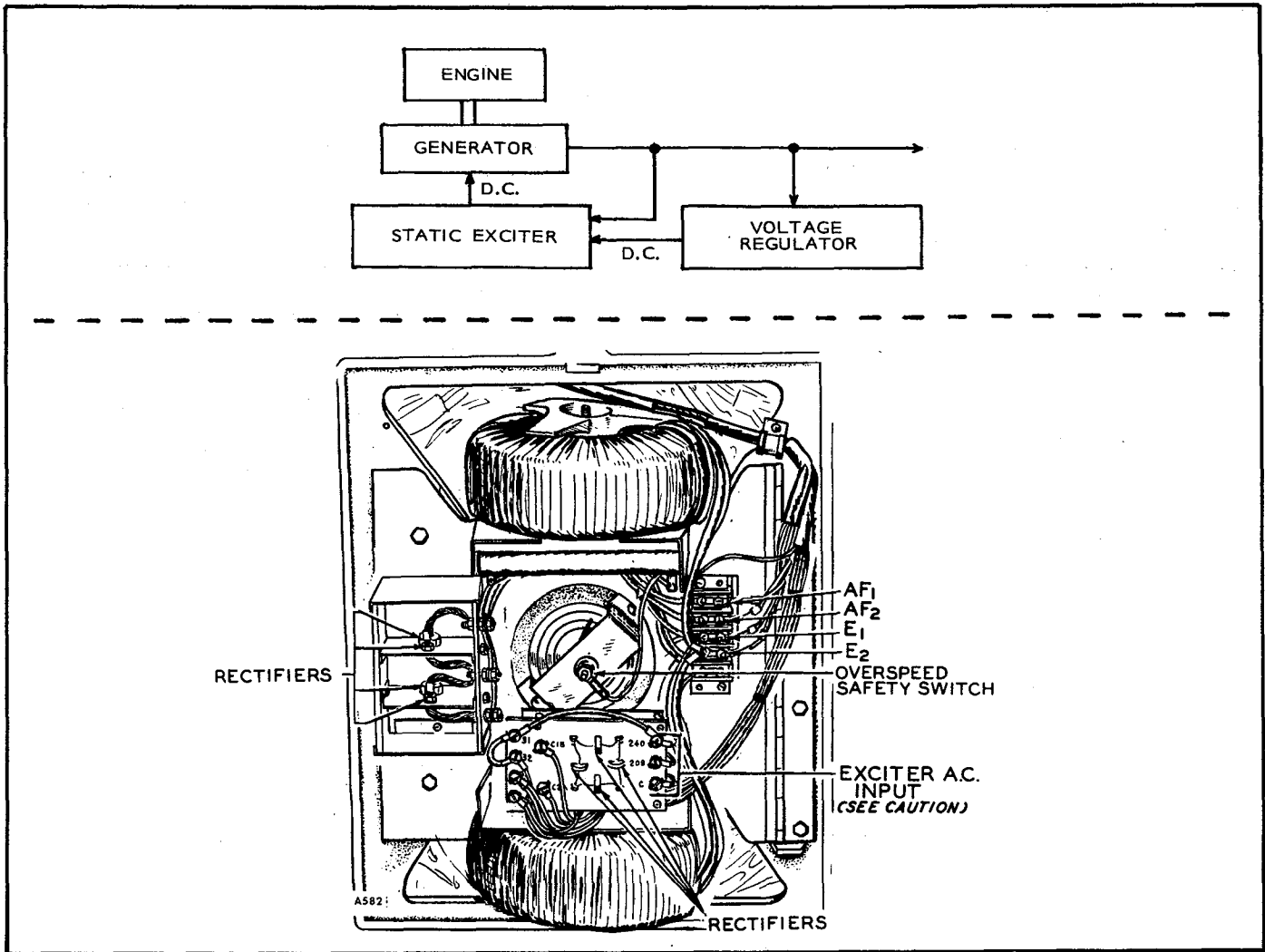

FIGURE 4-2. ONAN MAGNECITER

more than one method of checking a component or situation is given in the section on testing.

NOTE: It is imperative that the testing procedures are completely understood by the service technician before attempting to perform corrective procedures.

TESTING

CAUTION Avoid grounding the hot lead of a tester (Figure 4-3) when checking a Magneciter component installed on a generator. A tester with an isolation transformer circuit (Figure 4-4) is not subject to such a problem. This is the preferred type to use with a Magneciter.

Because more than one method of testing Magneciter components can be used, test procedures for both multimeters and continuity testers are outlined here.

METHOD A

Rectifier: Using an ohmmeter (multimeter)

1. Select the middle resistance range (RX10 or RX100) for measurements.

2. Isolate the rectifier by disconnecting one end from its point of connection.
3. Connect the test leads to the rectifier ends and observe the meter reading.
4. Reverse the leads and again observe the meter reading.

Results:

- a. RECTIFIER IS GOOD if one reading is much higher than the other.
- b. RECTIFIER IS DEFECTIVE if both readings are low, indicating the presence of a short, or if both readings are high, indicating the presence of an open circuit. In either case, the rectifier should be replaced.

Rectifier: Using 6-volt buzzer tester

1. Connect tester leads to rectifier ends.
2. Reverse the leads and connect again.

Results:

- a. RECTIFIER IS GOOD if there is a buzz for one connection and no buzz for the other.

TABLE 1. MAGNECITER TROUBLESHOOTING

NATURE OF TROUBLE	PROBABLE CAUSE	CORRECTIVE ACTION	METHOD
Generator will not build up voltage	Circuit breaker in "off" or "tripped" position	Reset and close breaker	None
	Open in circuit breaker	Stop plant and check breaker continuity	None
	No AC power to Magneciter	Check AC voltage at E1-E2 with the plant operating*. Voltage should be 5 percent of the rated voltage. If not, check continuity from E1-E2 back to the generator	None
	Shorted or Grounded Rotor	Replace Rotor	Ohmmeter or Series Test Light
	Contacts dirty in Build-up Relay of 02SX1N1A	Stop plant. Clean by drawing hard surfaced paper between contacts	None
	Partial loss of residual in Rotor	With plant operating*, short out reactor(s)	J or K
	Field Rectifiers W & Z or X & Y open	Test rectifiers and replace if defective	A or B
	Field Rectifiers X & Y shorted	Test rectifiers and replace if defective	A or B
Output voltage slow to build up. Circuit breaker opens in about five seconds	Either Field Rectifier X or Y shorted	Test rectifiers and replace if defective	A or B
Output voltage slow to build up. 5 percent below rated voltage. Poor voltage regulation	Either Field Rectifier W or Z shorted	Test rectifier and replace if defective	A or B
Output voltage slow to build up and higher than rated voltage after build up	Open circuit in one or more Control Rectifier	Test rectifier and replace if defective. Check soldered connections to rectifiers	A or B
Output voltage slow to build up and 10 to 20 percent above rated voltage after build up	Open in one Field Rectifier	Test rectifiers and replace if defective	D or E
	Open circuit in Gate winding G1-G2 of Reactor A or B	If Field Rectifiers Y and Z check okay, check continuities of Gate windings G1-G2	D or E

* **WARNING** USE CAUTION WHEN TROUBLESHOOTING A UNIT IN OPERATION! ELECTRICAL SHOCK HAZARD IS PRESENT.

TABLE 1. MAGNECITER TROUBLESHOOTING
(Continued)

NATURE OF TROUBLE	PROBABLE CAUSE	CORRECTIVE ACTION	METHOD
Output voltage builds up normally but less than rated voltage after build up	Shorted winding in Control Reactor	Test Control Reactor and replace if defective	F
Output voltage builds up normally with slightly less than rated voltage at no load and low voltage at full load	Compound winding S1-S2 installed backward or has open circuit	Check wiring diagram for polarity of Compound windings thru Reactors A and B and test for continuity	None
Output voltage builds up normally but 20 percent above rated voltage after build up. Voltage regulation poor.	Compound winding S1-S2 installed backward thru one Reactor (A or B)	Check wiring diagram for polarity of Compound winding thru Reactor A or B	None
Output voltage builds up normally but is 25 percent above rated voltage after build up	Open circuit in Control Rectifier bridge	Check continuity from the junction of Control Rectifiers Y and Z to the junction of Control Rectifiers W and X	C
Output voltage builds up normally but 125 to 150 percent above rated voltage after build up	Shorted turn in gate winding G1-G2 of Reactor A or B	Test Reactors A and B for shorted turns and replace if defective	D or E
Output voltage builds up normally but 150 to 200 percent above rated voltage after build up. No regulation possible	Control winding C1-C2 of Reactor A or B polarized incorrectly	Check circuit connections of both Reactors A and B	None
	Shorted turn in Control winding C1-C2 of Reactor A or B	Test Reactors A and B for shorted turn and replace if defective	D or E
	Relay inoperative	Check coil continuity; replace if defective	H
	Open in Control Circuit	Check continuity from E1 to E2 thru Control Circuit	None
Generator voltage fluctuating while engine running at constant speed	Incorrect setting on the Stabilizing Resistor	Check resistance and compare with resistance value in Table	G
Output Voltage High	Shorted Control Diode	Replace Diode	C

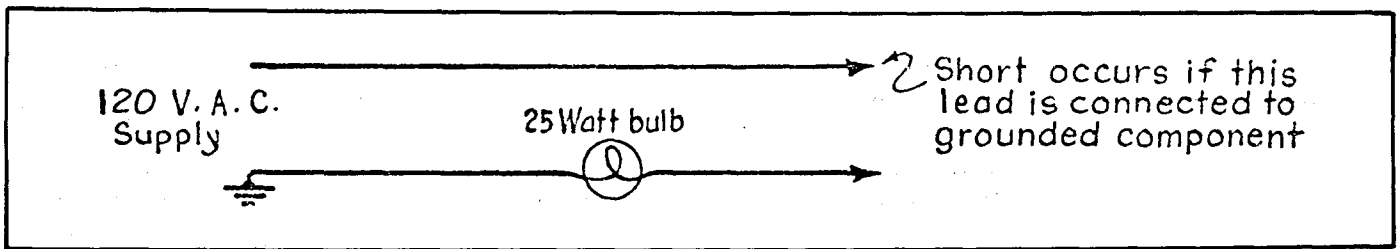

FIGURE 4-3. TEST LAMP SET

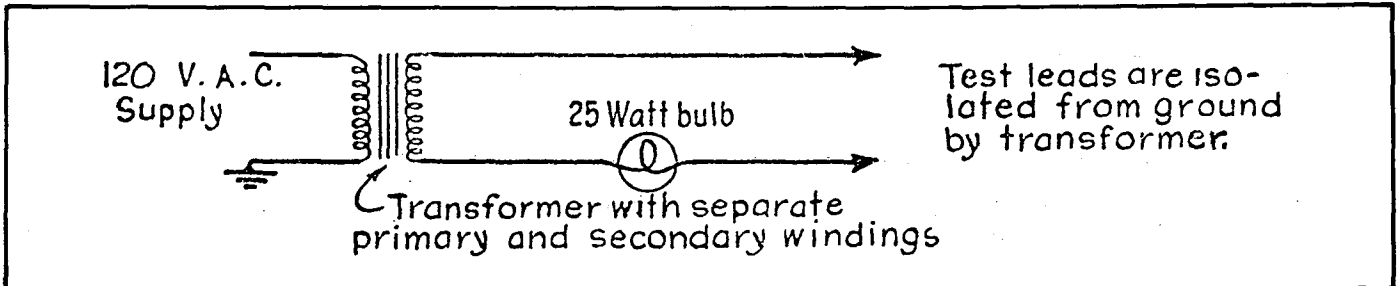

FIGURE 4-4. RECOMMENDED TEST LAMP SET

- b. RECTIFIER IS DEFECTIVE if (1) there is no buzz for either connection or (2) a buzz in both connections. In either case, replace the rectifier.

METHOD B

Rectifier: Using 120-volt AC tester

1. Make certain that no component part of the Magneciter is electrically grounded.
2. Isolate the rectifier by disconnecting one end from its point of connection.
3. Connect the two test leads together and observe the brilliance of the bulb. (Only the lead resistance is present in the test circuit.)
4. Connect the test leads to the rectifier and observe the brilliance of the bulb.

Results:

- a. RECTIFIER IS GOOD if the bulb lights with a low intensity.
- b. RECTIFIER IS DEFECTIVE if the bulb lights with high intensity, indicating the presence of a short, or if the bulb fails to light at all, indicating the presence of an open circuit. In either case, the rectifier should be replaced. **BE SURE TO INSTALL THE RECTIFIER IN THE PROPER DIRECTION. (SEE WIRING DIAGRAM FOR CORRECT POLARITY.)**

NOTE: Results which are questionable can be affirmed by testing a good rectifier.

METHOD C

Control Rectifier Bridge Circuit

1. Follow the above procedures for troubleshooting rectifiers. The multimeter will indicate no continuity in one direction or the other if an open circuit exists in the bridge circuit.

METHOD D

Reactors: Using an ohmmeter (multimeter)

These reactors are basically transformers having isolated primary and secondary windings. The reactors can be tested as transformers.

1. Select the resistance range on the meter to the resistance specified in Table 3 for a given rectifier model.
2. Isolate one gate winding by disconnecting either end of gate winding G1-G2 from its point of connection; for example, disconnect G1 at E2.
3. Measure the resistance in the gate winding across G1-G2.
4. Isolate the control winding by disconnecting either lead C1 or C2 from the terminal strip. Measure the resistance in the control winding across C1-C2.
5. Connect one meter lead to the disconnected gate winding lead and the other meter lead to the disconnected control winding lead and check for continuity.

Results:

- a. REACTOR IS GOOD if resistance is within ± 20 percent of the value listed in Table 3 and if there is also no continuity between the control and gate windings.
- b. REACTOR IS DEFECTIVE if there is an open circuit in either the gate or the control windings. Continuity between the gate and the control windings is also an indication of a defective reactor. In either case, the reactor should be replaced.

METHOD E

Reactors A and B: Using 120-volt AC tester

1. Remove exciter from generator.
2. Make certain that no part of the Magneciter is

grounded.

3. Isolate the gate winding by disconnecting one lead from its point of connection.
4. Isolate the control winding by disconnecting both leads C1 and C2 from their points of connection.
5. Connect one test lead to G1 and the other test lead to G2 and observe the light bulb.
6. With the test leads still connected to the gate winding leads, short across leads C1 and C2 and again observe the bulb.
7. Connect one test lead to the control winding lead and the other test lead to one of the gate winding leads and observe the bulb.

Results:

- a. REACTOR IS GOOD if bulb is dark for steps 5 and 7 but bright for step 6.
- b. REACTOR IS DEFECTIVE if bulb lights with low intensity for step 5, indicating the presence of a short in either the gate winding or the control winding. If the bulb lights for step 7, the gate winding and the control are shorted together. If the bulb fails to light in step 6, there is very likely an open circuit in either the gate winding or the control winding. Replacement is required.

METHOD F

Control Reactor: Using an ohmmeter only

This method of testing the control reactor is not always positive, but the meter reading will indicate a trouble if one exists.

1. Isolate the control reactor by disconnecting common lead "C" from its point of connection and carefully measure the resistance from this lead to the numbered lead on the control reactor.

Results:

- a. CONTROL REACTOR IS GOOD if resistance is within 10 percent of the value specified in Table 1.
- b. CONTROL REACTOR IS DEFECTIVE if no resistance is indicated between the common lead "C" and the numbered lead. (Open circuit is indicated.)

METHOD G

Resistor: Using an ohmmeter only

1. The resistance should be measured with an ohmmeter. See Table 3 for selecting the resistance range (RX10, RX100, etc.) so readings are near center of meter scale.
2. Isolate the resistor by disconnecting one end from its point of connection before measuring the resistance.

Results:

- a. RESISTOR IS GOOD if the measured resistance

falls within ± 20 percent either way of the value given in Table 3.

- b. RESISTOR IS DEFECTIVE if there is no indication of continuity through the resistor or if the measured resistance exceeds the allowable tolerance.

NOTE: *The stabilizing resistor can be adjusted to bring the specified resistance within the required limits.*

METHOD H

Build-up Relay Coil: Using an ohmmeter

This test will determine whether the resistance through the coil winding is within tolerance.

1. Isolate the coil by disconnecting one of its leads. With the meter adjusted to indicate center scale resistance reading, connect the meter leads to the coil.

Results:

- a. COIL IS GOOD if 525 ohms ± 10 percent resistance is measured.
- b. COIL IS DEFECTIVE if no resistance or low resistance is indicated; replace the relay.

METHOD J

Producing Voltage Build-up:

The first method used is shorting out the gate reactor(s) (temporarily removing their resistance) and thus applying full residual voltage to alternator field. Refer to diagrams to locate *terminal points* for the jumper connections. *Have set running but be cautious!*

1. For 04SX and 06SX press residual reset switch in Magneciter.
EXCEPTION: For Spec A, which has no switch, place a jumper joining G1 - G2 - E2. Remove jumper wires when AC voltage starts to build up.
2. For 07SX, 102SX, and 2SX, jumper E2 to heat sink of rectifier No. 1. Remove jumper wires when AC voltage starts to build up.

METHOD K

Restoring Residual Magnetism: Flashing the field (Figure 4-5)

If output voltage won't build up after trying Method J, then it may be necessary to restore residual magnetism by flashing the field with a *separate* battery. Connect a voltmeter across terminals E1 and E2. After starting the set touch the positive leads of a 6-volt dry cell lantern battery to F1 positive (+) and the negative (-) lead to F2. When voltage starts to build-up, remove the battery leads. If voltage does not build up to normal and then drops to zero when you remove the battery leads, the trouble is a faulty component(s) in the exciter.

NOTE: You may substitute a 12-volt automotive battery for the 6-volt lantern battery if a 10-ohm resistance is connected in series with the battery to limit current to the exciter circuit.

AUTOMATIC FIELD FLASHING (Figure 4-5)

Some new units have an automatic field flashing circuit which uses the set battery to "flash the field" when the engine cranks. This helps insure voltage buildup. All generators use this circuit except the 5DR and 4XR models. The circuit is identified by the additional field rectifier ("V") shown on the set exciter wiring diagram.

Two things are necessary for this circuit to work properly:

1. The plant battery must be negative ground.
2. Alternator lead T2 must be grounded (T2 must be grounded on a 3-phase, 4 wire.)

CAUTION If these conditions are not followed, the field flashing circuit will be ineffective or it may damage the exciter.

INSTALLING NEW RECTIFIERS (Figure 4-6).

Observe caution when installing a new field rectifier. Applying too much torque on the holding nut will strain the internal connection and cause premature failure. Small rectifiers used on the J series should not be torqued over 20-inch lbs. If no torque wrench is available this is finger-tight plus one-quarter turn.

Larger rectifiers require 35 to 40-inch lbs. of torque.

EXCITER VOLTAGE TEST (Figure 4-7).

A. Bench Test (Auxiliary Power)

1. Connect Variac to exciter terminals E1 and E2 as shown in Figure 5.
2. Connect an AC voltmeter to these same terminals E1 and E2.

3. Connect DC voltmeter to field leads F1 and F2.
4. Connect a 100 watt light bulb across these same terminals F1 and F2.
5. Adjust Variac until voltage reaches value shown in column 2 (according to exciter model shown on Onan nameplate). DC voltage should now be within limits shown in column 3. (TABLE 4-2).

B. Generator Running at No Load

1. Connect an AC voltmeter to exciter terminals E1 and E2 as shown in Figure 4-8.
2. Connect DC voltmeter to exciter terminals F1 and F2.
3. With generator running at recommended rpm and no load connected, AC voltage values should be the same as those given in column 1; DC voltage values should be the same as those shown in column 2 (according to exciter model). SEE TABLE 4-3.

MAINTENANCE AND ADJUSTMENTS

J-Series

Revolving field generators normally need little care other than periodic inspection of the exciter, ball-bearing, collector rings, and brushes. These items must be inspected at least every 1000 hours.

NOTE: J-series generator sets using 02SX exciters require voltage build-up relay cleaning every 500 hours.

Brushes (J-Series)

To examine the brushes, brush springs, and slip rings the exciter cover at the rear of the generator must be removed. The exciter mounts on a hinged plate. Remove the screw from the right side of the plate and swing the assembly outward. To remove the brush holders unscrew the four machine screws on the end-bell near the ballbearing (Figure 4-9).

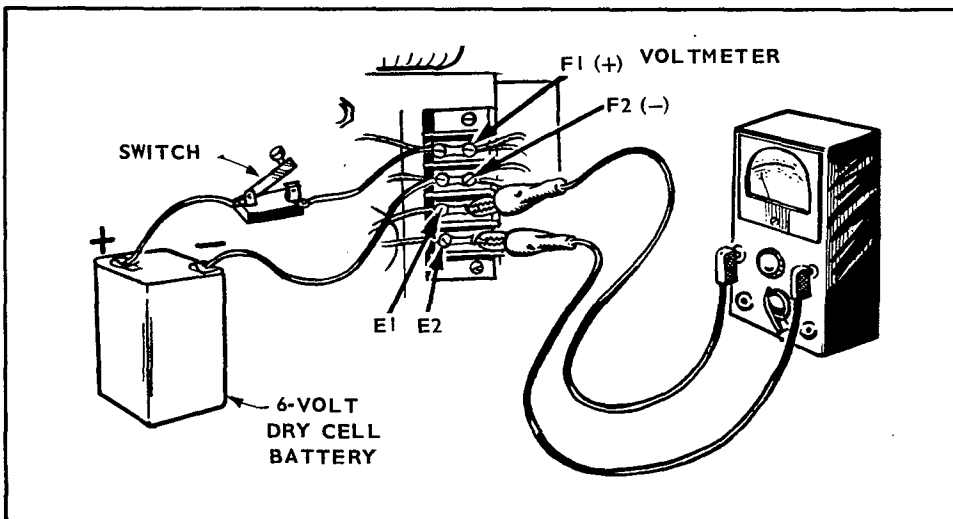

FIGURE 4-5. FLASHING THE FIELD

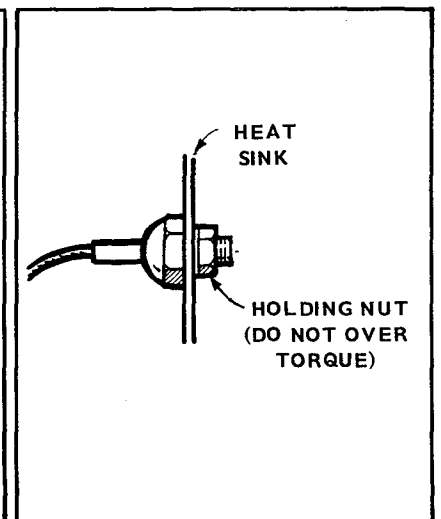

FIGURE 4-6. INSTALLING NEW RECTIFIERS

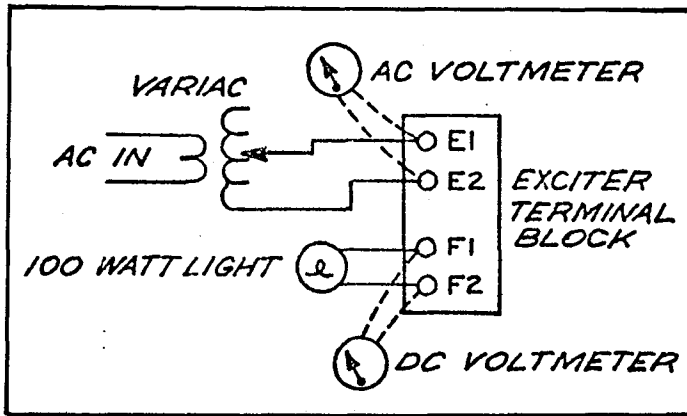

FIGURE 4-7. BENCH TEST SCHEMATIC

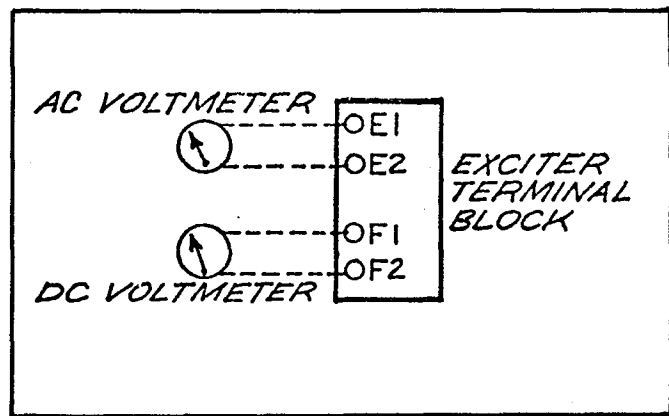

FIGURE 4-8. TEST SCHEMATIC (GENERATOR RUNNING AT NO LOAD)

TABLE 4-2. VOLTAGE VALUES FOR BENCH TEST

EXCITER MODEL	1 NOMINAL EXCITER VOLTAGE	2 AC VOLTS AT FIRE DOWN *	3 DC VOLTS AT FIRE DOWN *
04SXIN	120	138-140	60-80
06SXIN	120	122-129	60-80
06SX5IN	120	146-150	70-90
07SXIN	120	116-119	60-80
07SX5IN	120	136-140	70-90
102SXIN	120	118-119	70-90
102SX5IN	120	133-140	80-100
2SXIN	240	236-240	150-170
	208	208-210	130-150
2SX5IN	240	258-262	150-170
	208	222-228	130-150

NOTE: All bench test values are the same for 50 cycle and 60 cycle models.

* - Value will vary with rheostat setting.

TABLE 4-3. VOLTAGE VALUES FOR EXCITER (GENERATOR RUNNING AT NO LOAD)

EXCITER MODEL	NOMINAL EXCITER VOLTAGE	1 AC VOLTAGE AT E1, E2	2 DC VOLTAGE AT F1, F2	3 ENGINE SPEED
04SXIN	120	124	21	1860
06SXIN	120	126	22	1860
07SXIN	120	123	21	1860
102SXIN	120	122	19	1860
2SXIN	240	253	39	1875
	208	215	36	1860

NOTE: Values will vary with engine speed and rheostat setting. All values at no load.

TABLE 4-4. RESISTANCE VALUES

CAUTION Always use an accurate ohmmeter for checking resistance values. Resistance readings in the range of values found between G1 and G2 cannot be read with accuracy on the multimeter.

MODEL OF MAGNECITER	CONTROL REACTOR			LARGE REACTOR			STABILIZING RESISTOR SETTINGS
	from C to 25	from C to 31	from C to 4	from C to 1	from C1 to C2	from G1 to G2	
02SX1N1A				14.0	5.0	1.0	Fixed
07SX1N1A	23.0				9.0	.75	113.0
07SX1N1B	23.0				9.0	.75	113.0
07SX1N1C		18.0			9.0	.75	150.0
102SX1N1A	23.0				8.5	.30	80.0
102SX1N1B		18.0			8.5	.30	80.0
2SX2N1A			155.0		17.5	.37	Fixed
2SX2N1B				150.0	17.5	.37	Fixed
07SX51N1A	28.0				9.0	.90	113.0
07SX51N1B	28.0				9.0	.90	113.0
07SX51N1C		22.0			9.0	.90	150.0
102SX51N1A	28.0				8.5	.35	80.0
102SX51N1B		22.0			8.5	.35	80.0
2SX52N1A			192.0		17.5	.45	Fixed
2SX52N1B			180.0		17.5	.45	Fixed
04SX1N1A		12.5			11.0	1.77	Fixed
04SX1N1B, 2B, 3B, 4B		12.5			11.0	1.77	Fixed
06SX1N1A		12.5			5.5	.66	Fixed
06SX1N1B, 2B, 3B, 4B		12.5			5.5	.66	Fixed
06SX51N1A		15.0			6.6	.79	Fixed
06SX51N1B, 2B, 3B, 4B		15.0			6.6	.79	Fixed

TABLE 4-5. MAGNECITER DIAGRAMS

2SX MAGNECITER
07SX AND 102SX MAGNECITER
04SX AND 06SX MAGNECITER
WITH AND WITHOUT AUTOMATIC FIELD FLASHING
02SX1N1A MAGNECITER

TYPICAL DIAGRAM OF 2SX MAGNECITERS

PICTORIAL

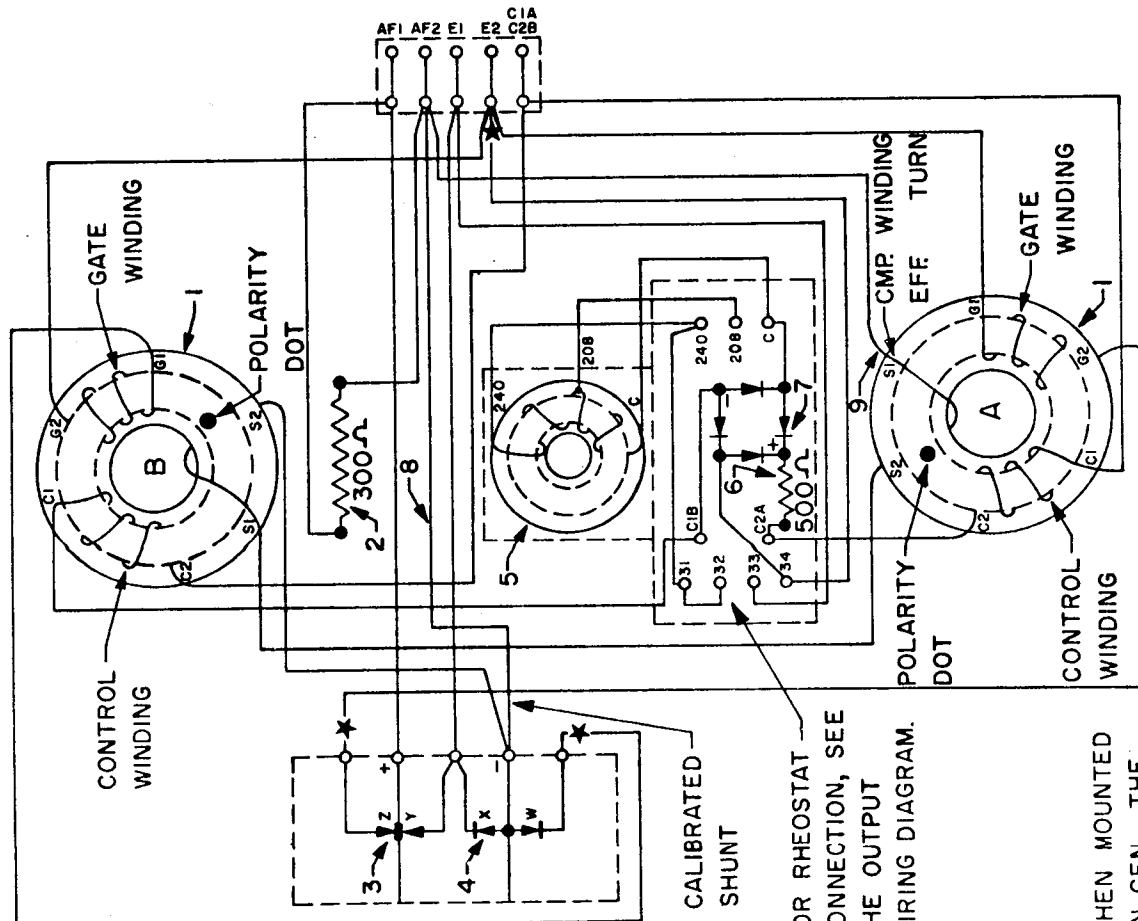

CALIBRATED SHUNT
FOR RHEOSTAT CONNECTION, SEE THE OUTPUT WIRING DIAGRAM.

WHEN MOUNTED ON GEN., THE POLARITY DOTS WILL BE ON TOP OF EACH REACTOR.

SCHEMATIC

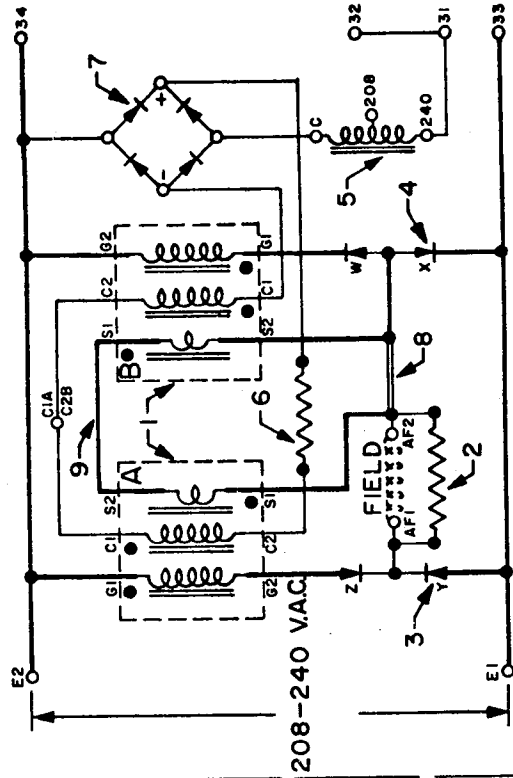

ITEM	QTY	DESCRIPTION
9	1	NO. 12 WIRE, 40" LG.
8	1	NO. 12 WIRE, 20" LG.
7	4	RECTIFIER-CONTROL
6	1	RESISTOR-STABILIZING
5	1	REACTOR-CONTROL
4	2	RECTIFIER-FIELD, NEG.
3	2	RECTIFIER-FIELD, POS.
2	1	RESISTOR-DAMPING
1	2	REACTOR-GATE

PARTS LIST

★ JUMPER CONNECTION POINTS FOR METHOD J. TESTING

TYPICAL DIAGRAM OF 07SX AND 102SX MAGNECITERS

PICTORIAL

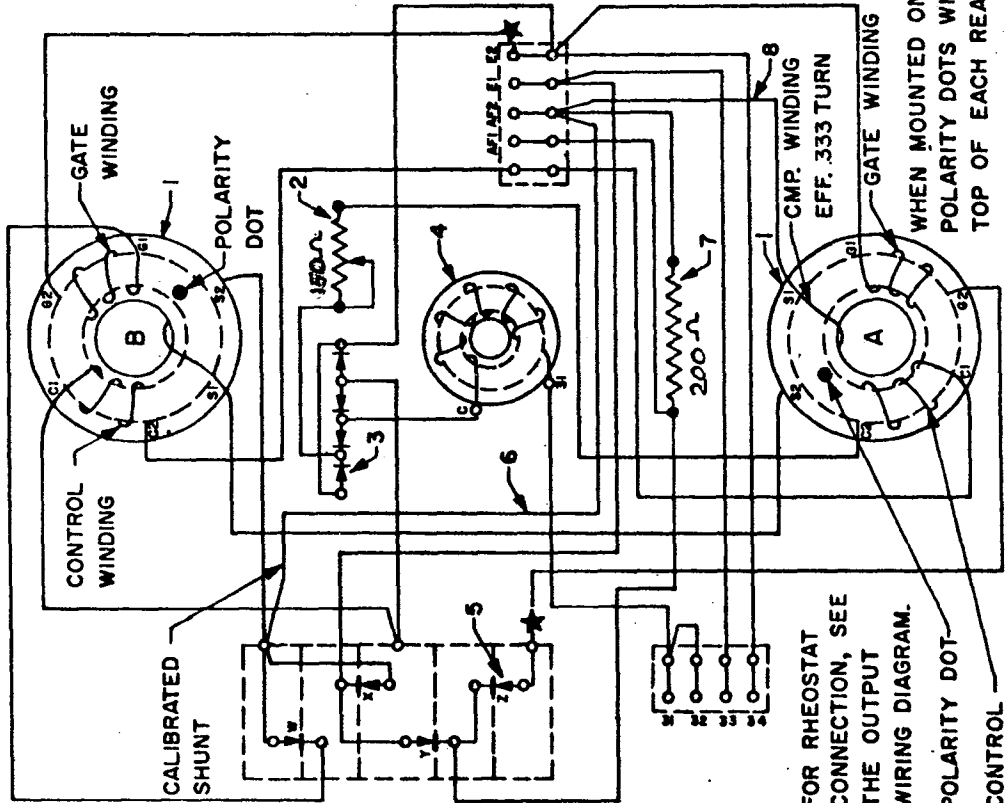

FOR RHEOSTAT CONNECTION, SEE THE OUTPUT WIRING DIAGRAM.

POLARITY DOT - CONTROL WINDING

WHEN MOUNTED ON GEN., THE POLARITY DOTS WILL BE ON TOP OF EACH REACTOR.

SCHEMATIC

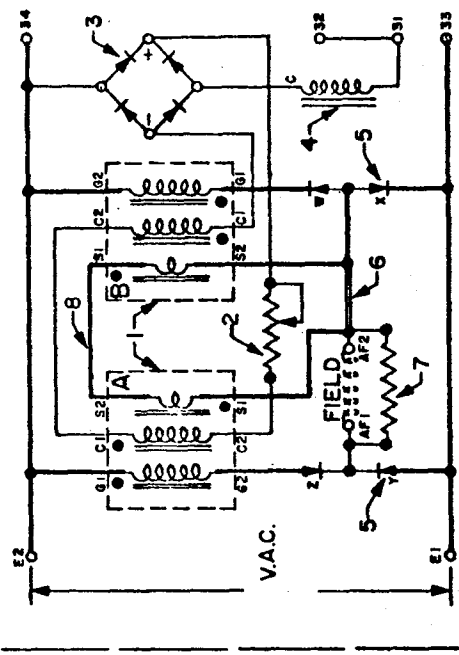

ITEM	QTY	DESCRIPTION
8	1	NO. 14 WIRE, 27" LG.
7	1	RESISTOR-DAMPING
6	1	NO. 14 WIRE, 13 1/2" LG.
5	4	RECTIFIER-FIELD
4	1	REACTOR-CONTROL
3	4	RECTIFIER-CONTROL
2	1	RESISTOR-STABILIZING
1	2	REACTOR-GATE

PARTS LIST

★ JUMPER CONNECTION POINTS FOR METHOD J. TESTING

TYPICAL DIAGRAM OF 04SX AND 06SX MAGNECITERS

PICTORIAL

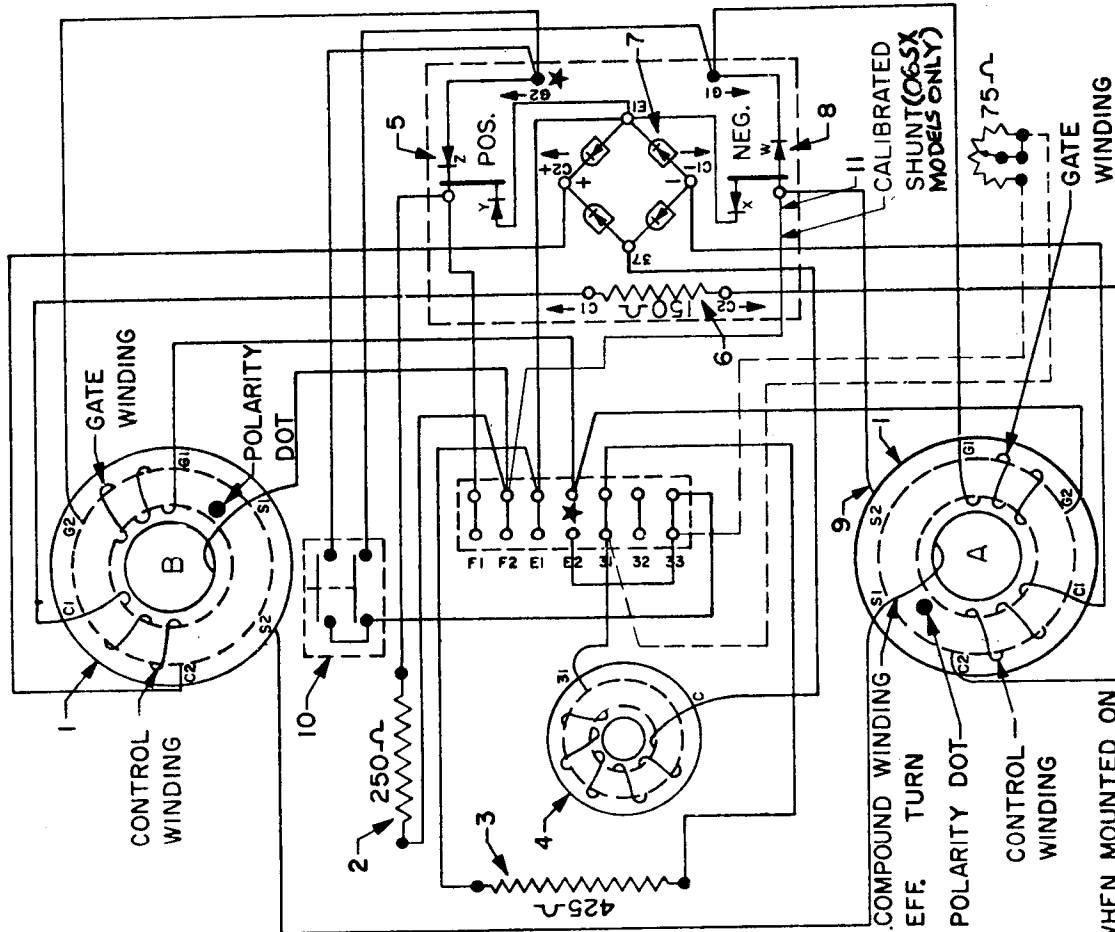

WHEN MOUNTED ON GEN., THE POLARITY DOTS WILL BE ON TOP OF EACH REACTOR.

SCHEMATIC

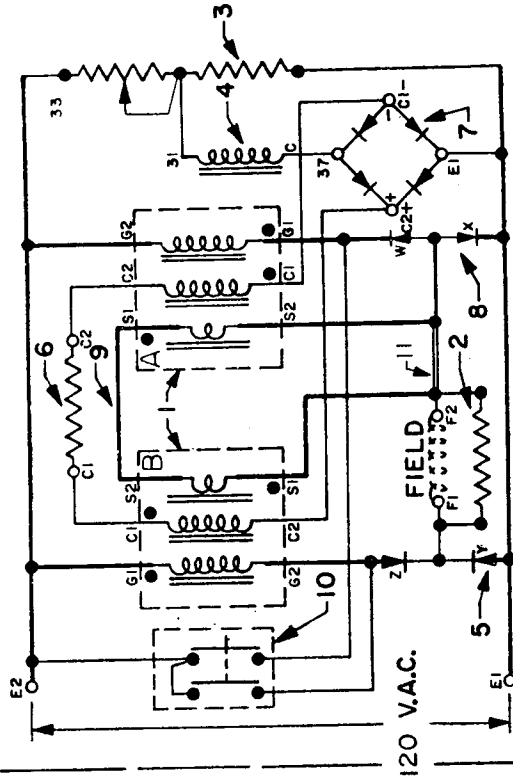

ITEM	QTY	DESCRIPTION
11	1	NO. 16 WIRE, 27 1/2" LG.
10	1	SWITCH-RESIDUAL RESET
9	1	NO. 14 WIRE, 27 1/2" LG.
8	2	RECTIFIER-FIELD NEG.
7	4	RECTIFIER-CONTROL
6	1	RESISTOR-STABILIZING
5	2	RECTIFIER-FIELD POS.
4	1	REACTOR-CONTROL
3	1	RESISTOR-VOLT. CONTROL
2	1	RESISTOR-DAMPING
1	2	REACTOR-GATE

PARTS LIST

★ JUMPER CONNECTION POINTS FOR METHOD J. TESTING

TYPICAL DIAGRAM OF 04SX AND 06SX MAGNECITERS
WITH AUTOMATIC FIELD FLASHING

PICTORIAL

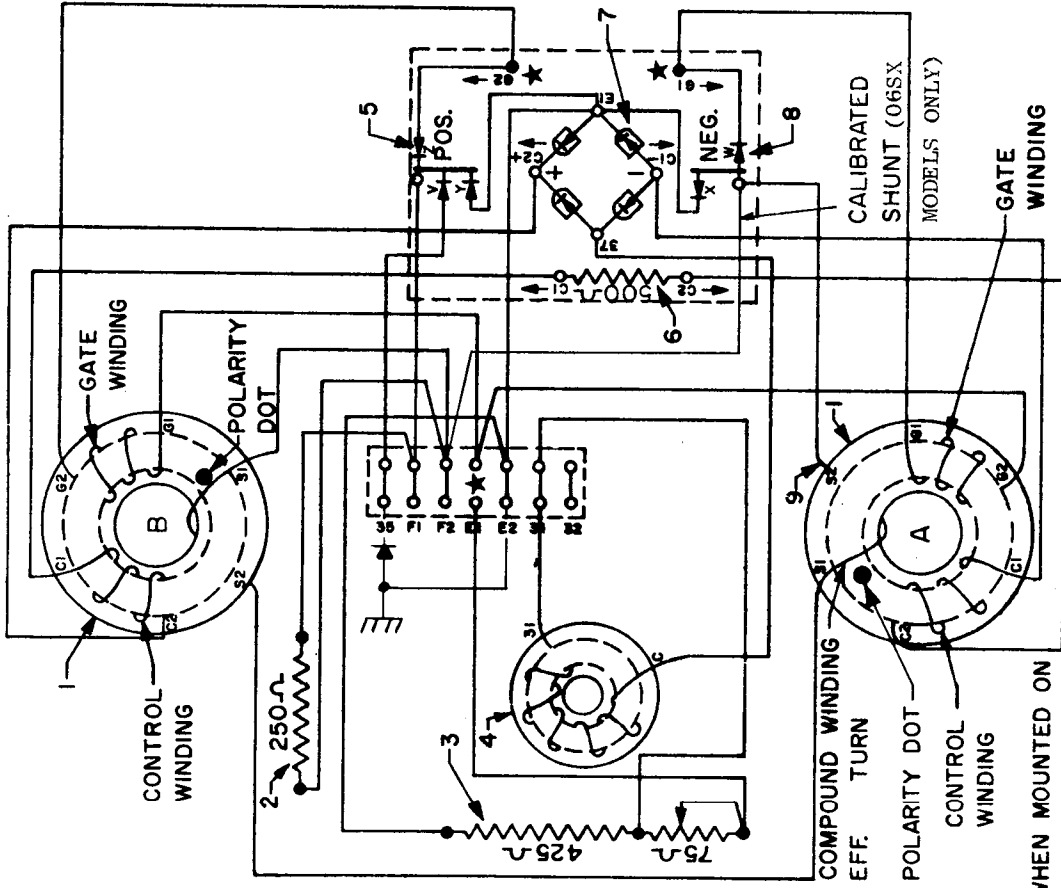

WHEN MOUNTED ON GEN., THE POLARITY DOTS WILL BE ON TOP OF EACH REACTOR.

SCHEMATIC

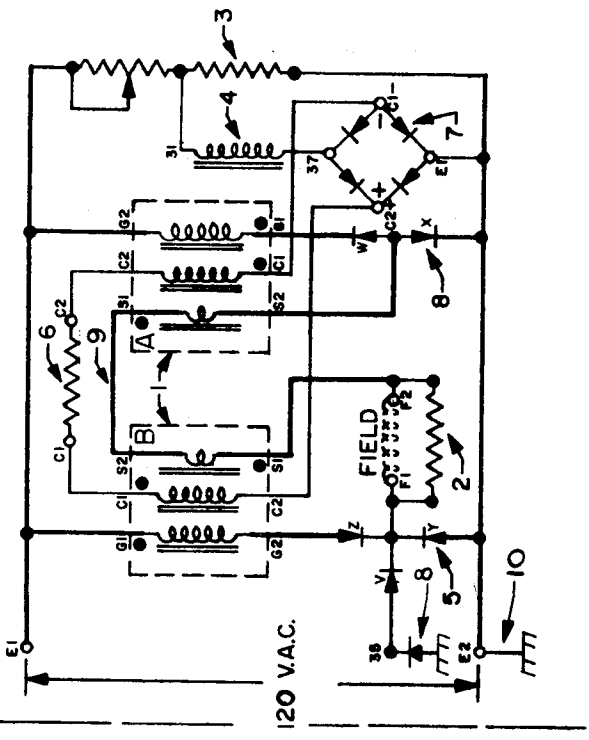

ITEM	QTY	DESCRIPTION
10	1	LEAD ASSY
9	1	NO. 14 WIRE, 27 1/2" LG.
8	3	RECTIFIER-FIELD NEG.
7	4	RECTIFIER-CONTROL
6	1	RESISTOR-STABILIZING
5	3	RECTIFIER-FIELD POS.
4	1	REACTOR-CONTROL
3	1	RESISTOR-VOLT. CONTROL
2	1	RESISTOR-DAMPING
1	2	REACTOR-GATE

PARTS LIST

★ JUMPER CONNECTION POINTS FOR METHOD J. TESTING

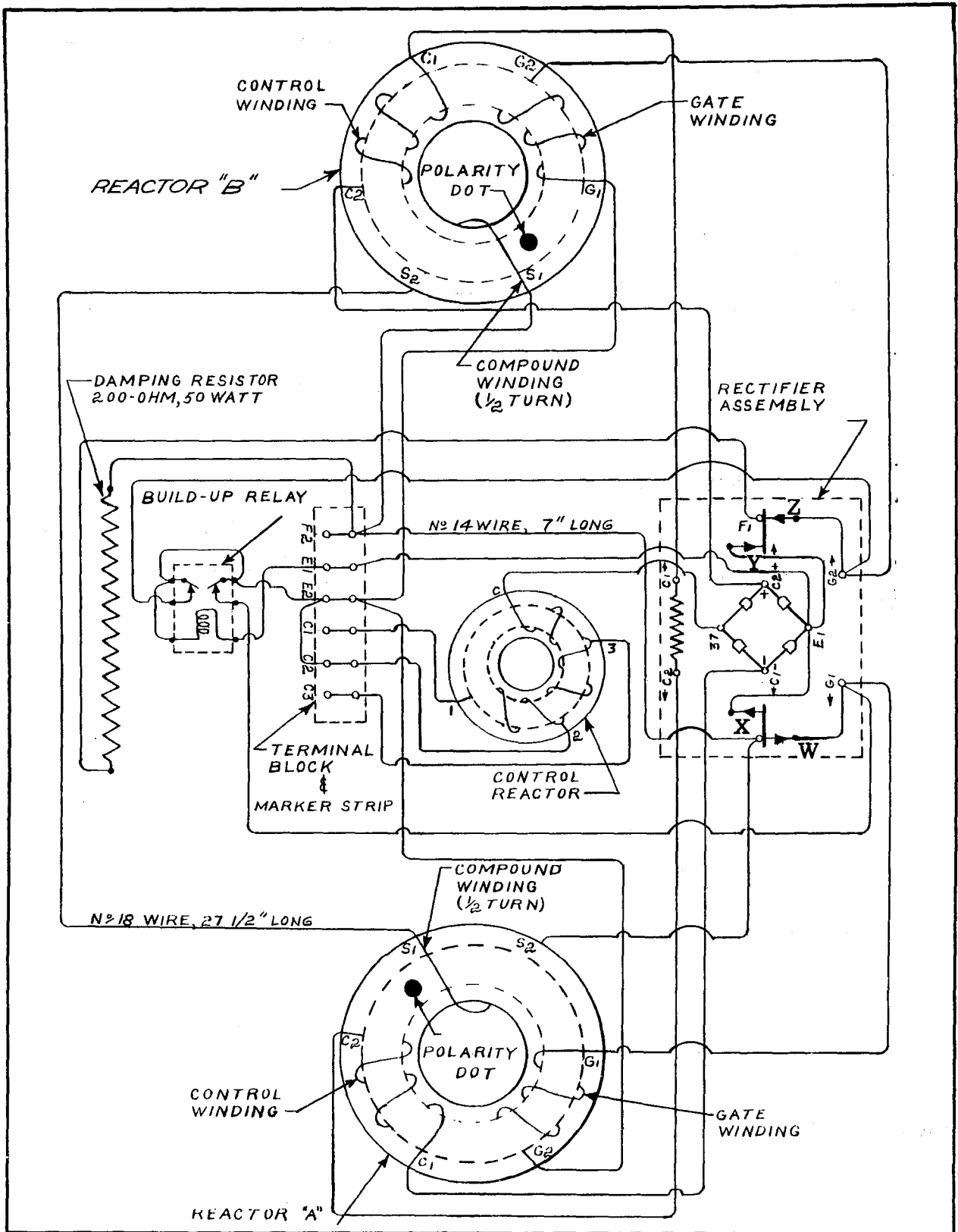

02SX1N1A MAGNECITER

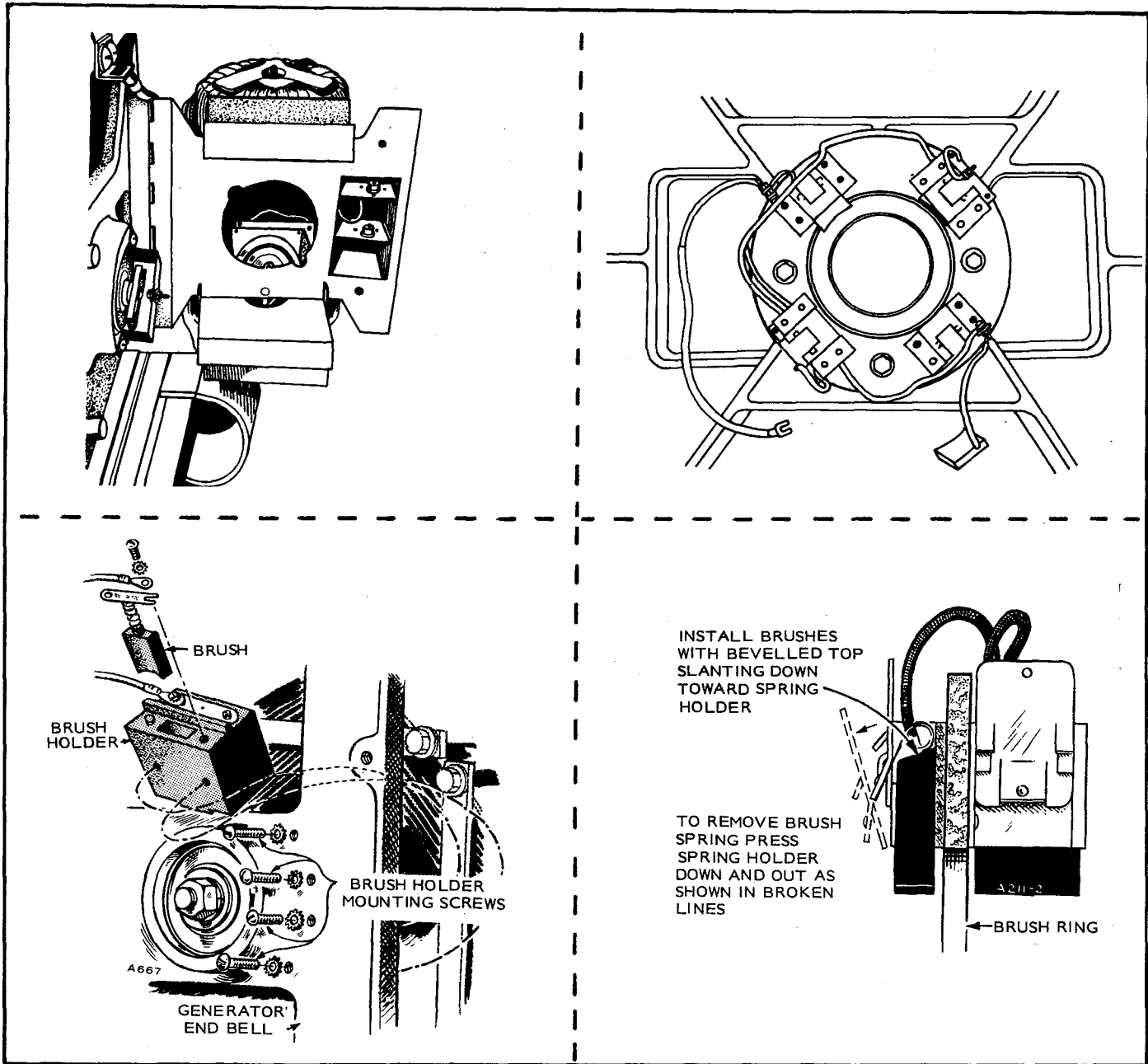

FIGURE 4-9. BRUSH LOCATION AND REPLACEMENT

Brushes should be replaced when they wear to about 5/16 inch.

CAUTION Use only Onan parts when replacing brushes. Other replacement brushes may look identical but they may have entirely different electrical characteristics.

TESTING AND REPAIR

If repair work is necessary on the generator, it should be performed by a competent electrician who is familiar with operation of electric generating equipment.

TROUBLESHOOTING

In the event of abnormal generator output voltage, observe the following procedures.

No Voltage Buildup: Remove the exciter cover and with the set running, operate the residual reset button on the Magneciter.

NOTE: Early 04SX and 06SX models had no reset button. On these models place jumpers momentarily from G1 to G2 of each reactor simultaneously with the unit running. On the 02SX exciter, the buildup relay automatically performs this function. Units beginning Spec P have a voltage tap at terminal 35 which allows automatic field flashing during unit cranking to assure voltage buildup.

If output voltage won't buildup after pushing the reset button, flash the field (Figure 4-11). Connect a voltmeter across the AC output. Then run the unit and

momentarily touch the leads of a 6-volt lantern battery to the exciter to brush leads . . . positive (+) to F1 and negative (-) to F2.

While viewing the voltmeter:

1. If voltage builds up to normal, trouble was due to lost residual in the field.
2. If voltage is low, the Magneciter is probably defective. (See *Magneciter Troubleshooting Chart*.)
3. If there is no voltage output with battery connected to F1 and F2, trouble is in alternator.

Over-Voltage or Fluctuating Voltage: If the engine is operating at the correct speed, see *Magneciter Troubleshooting Chart*.

GENERATOR BEARING

The generator ballbearing is prelubricated and double-sealed. Inspect every 1000 hours with the unit running.

If the set is used for "standby power", replace bearing every five years. If used as "prime power", replace bearing every 10,000 hours or two years. Deterioration of the bearing grease due to oxidation makes this replacement necessary.

If the bearing becomes noisy, worn or otherwise defective, replace it. Remove the old ballbearing with a gear puller and press a new one into place (Figure 4-10).

COLLECTOR RINGS

The collector rings must be clean and free of burrs, scratches and marks. If necessary, use No. 00 sandpaper to clean the surface. Never use emery cloth or other conducting abrasives.

Collector rings may have a dark brown or black appearance. This is a thin lubricating film and aids the life

of the brushes and slip rings. (Do not remove film.)

If the collector rings are grooved, out-of-round, pitted or rough so that good brush seating can't be maintained, remove the rotor and refinish the rings in a lathe. Remove or shield the ballbearing during refinishing. The collector rings should have a Total Indicated Reading (T.I.R.) of .002".

MAGNECITER

The magneciter contains no moving parts except for the O2SX. Periodically blow out any dust and make certain that all components and connections are secure.

For detailed magneciter description see the *Magneciter Description, Troubleshooting, and Repair* portion of this section.

ALTERNATOR TESTING

Most alternator testing can be performed without disassembling the generator.

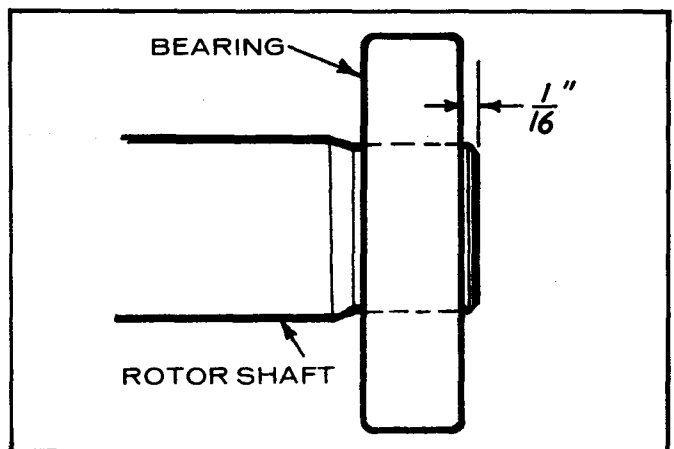

FIGURE 4-10. BEARING INSTALLATION.

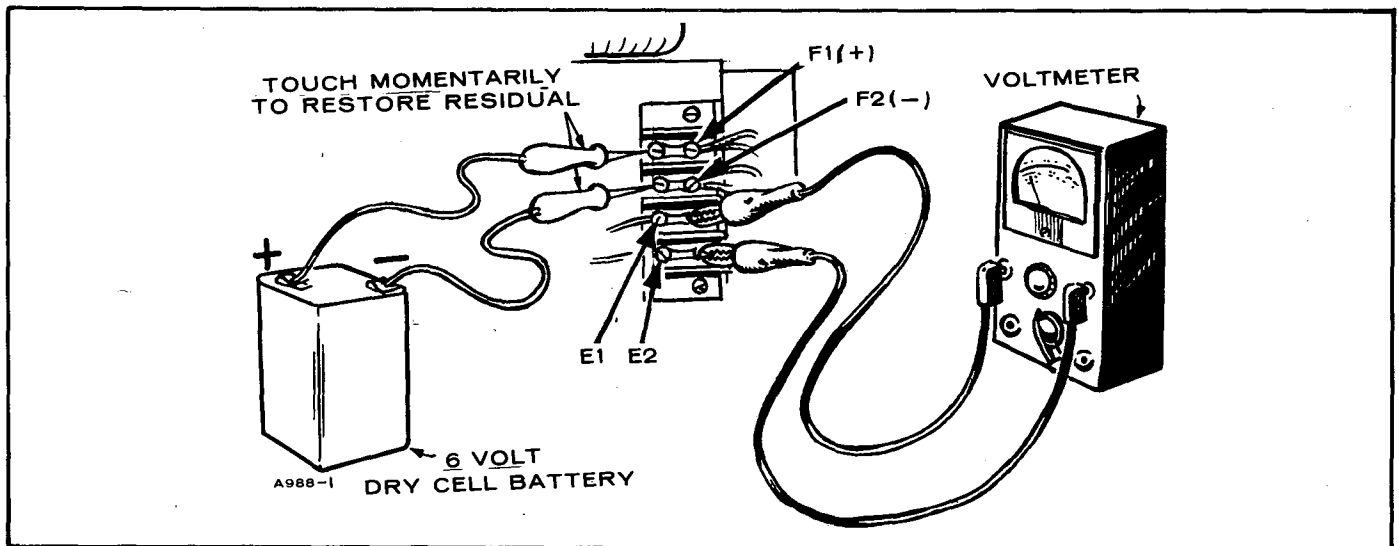

FIGURE 4-11. FLASHING THE FIELD.

Test Rotor Continuity As Follows:

Remove the brushes so none touch the collector rings.

1. Using an ohmmeter, test for grounding between each slip ring and the rotor shaft.
2. Test for a short or open circuit in rotor winding by measuring resistance of winding. It should measure between 3.5 and 4.8 ohms for the JB and between 2 and 3 ohms for the JC (at 70°F). If an accurate ohmmeter isn't available, check the rotor for open circuit or grounding with an AC test lamp (Figure 4-12). Replace the rotor if it is grounded, or has an open circuit or short.

Test Stator Continuity As Follows:

1. Disconnect the generator output leads in the control box. Use the wiring diagrams to determine the output leads in the control box. Use the wiring diagrams to determine the output lead coding. Using either the test lamp or an ohmmeter, check each winding of the stator for grounding to the laminations or frame.

NOTE: Some generators have ground connections to the frame. Check the wiring diagrams.

2. Using an accurate ohmmeter, test the resistance of each stator winding. Compare the resistances obtained. All windings of equal output voltage should indicate about the same resistance. An unusually low reading indicates a short; a high reading an open circuit. If the ohmmeter required for this test isn't available, check for open circuits with the test lamp.
3. If any windings are shorted, open-circuited or grounded, replace the stator assembly. Before replacing the assembly, check the leads for broken wires or insulation and replace any defective lead. If this does not correct the fault, replace the assembly. Only a competent rewinding shop should attempt to rewind a defective stator.

Battery Charging Winding Tests: Remove the lead from

from the battery polarity reconnection block to ammeter at the ammeter. Install a DC voltmeter between the lead and ground. At governed engine speed, the average DC output should be 19 to 21 volts. If the output is defective, test for open circuit or grounding in the leads and windings. If leads are defective, replace them. If the winding is defective, replace the stator.

GENERATOR DISASSEMBLY (Figure 4-14)

1. Disconnect the battery to prevent accidental starting of the set.
2. Remove the exciter cover and open the exciter. This will reveal the rotor-thru-stud nut.
3. Remove the four machine screws on the end bell near the bearing and lift out the brush holders.
4. Remove the lead from the tapped adjustable resistor in the generator air outlet opening.
5. Remove the leads from the control box to the ignition system choke, start disconnect switch, etc. on the engine.
6. Remove generator-through-stud nuts, remove the end bell and stator assembly. Screwdriver slots in the adapter provide a means for prying the stator loose. Be careful not to let the stator touch or drag on the rotor.
7. Remove baffle ring from adapter. Turn rotor-through-stud nut to the end of the through stud. While pulling the rotor outward with one hand, strike a sharp blow to the nut (in the direction of the through stud, *not vertically*) with a heavy, soft faced hammer to loosen the rotor from its tapered shaft fit. If the rotor does not come loose, strike it with a sharp downward blow in the center of the lamination stack with a lead or plastic hammer. Rotate the rotor and repeat until it comes loose. Be careful not to hit the collector rings, bearings or windings.
8. After disassembly, all parts should be wiped clean and visually inspected.

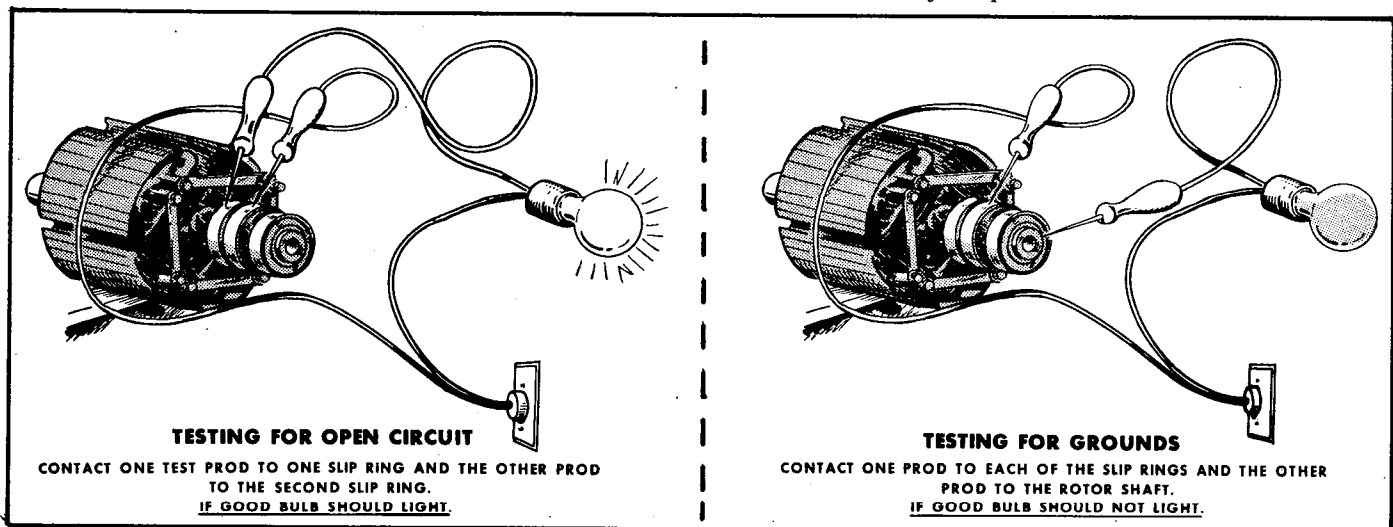

FIGURE 4-12. TESTING FOR OPEN CIRCUIT AND GROUNDS.

GENERATOR ASSEMBLY

1. Clean and inspect all mating surfaces.
2. Coat the mating area between the generator shaft and the engine crankshaft with a thin film of lubricating oil, "Molykote" or equal.
3. Install the rotor-through-stud in the engine crankshaft.
4. Install the key in the crankshaft.
5. Slide the rotor over the through-stud and onto the crankshaft. Be careful not to let the weight of the rotor rest on the through-stud.
6. Install the baffle ring.
7. Install generator through studs in the adapter.
8. Install the stator and bearing support (end bell). Tighten the nuts on through-studs.

NOTE: Make certain the B1 lead is placed through the grommet in the baffle ring and out the air discharge opening in the adapter.

9. Now torque down the rotor-through-stud nut (55-60 ft. lb.). Because the stator and bearing support were tightened before tightening the rotor, the rotor and stator are automatically aligned.
10. Tap the bearing support to the horizontal and vertical plane with a lead hammer to relieve stresses on the components (recheck torque).
11. Reconnect the leads to the preheater, centrifugal switch and governor solenoid.
12. Install lead B1 on the adjustable resistor.

CAUTION Check this lead to see that it is short and is kept away from the blower. If necessary when installing a new stator or leads, cut it shorter and reinstall the connector.

13. Install the brushes and brush holders.
14. Close the Magneciter, secure with four capscrews and install the end cover.

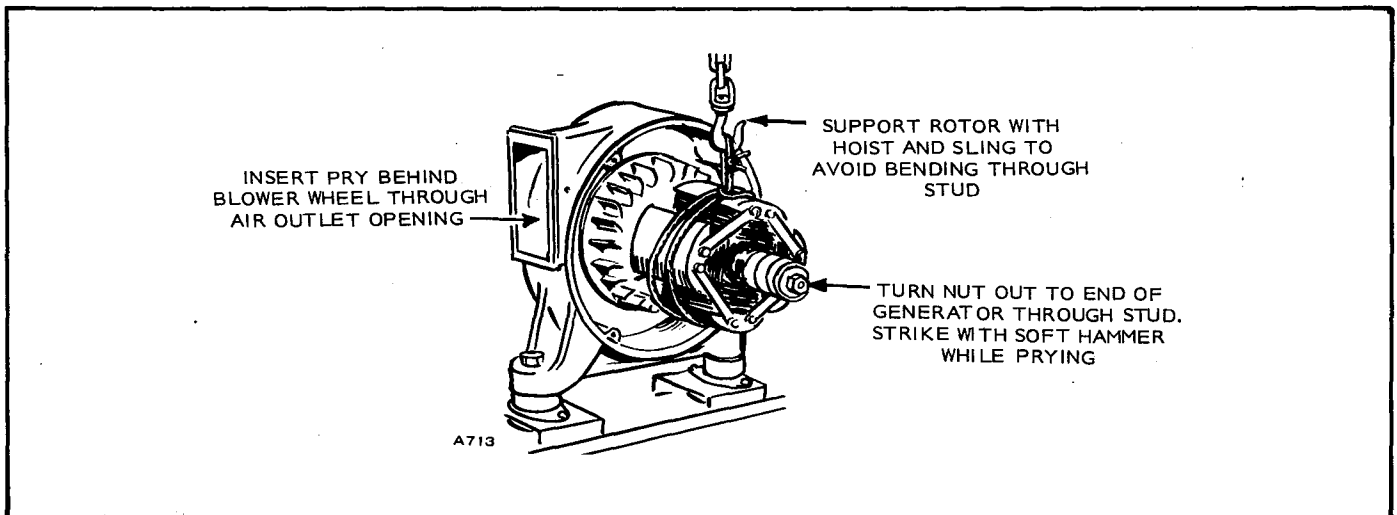

FIGURE 4-13. SUPPORTING THE ROTOR

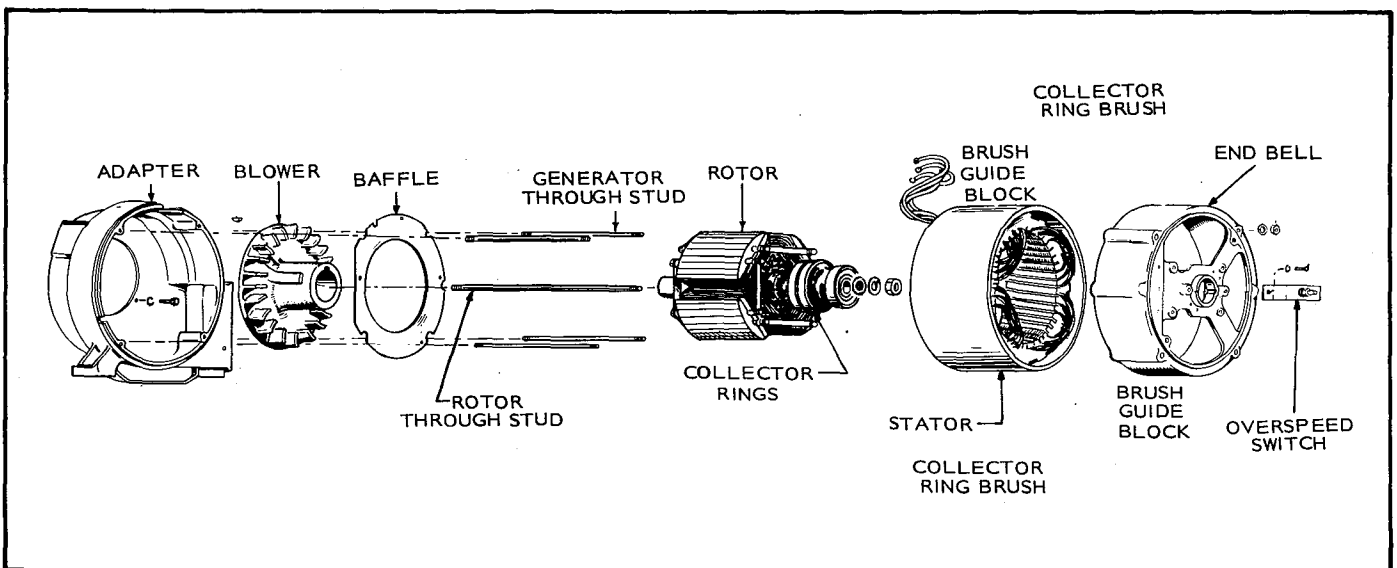

FIGURE 4-14. REVOLVING FIELD GENERATOR ASSEMBLY.

